



HAL
open science

Exact simulation of the genealogical tree for a stationary branching population and application to the asymptotics of its total length

Romain Abraham, Jean-François Delmas

► To cite this version:

Romain Abraham, Jean-François Delmas. Exact simulation of the genealogical tree for a stationary branching population and application to the asymptotics of its total length. 2016. hal-01413614v1

HAL Id: hal-01413614

<https://hal.science/hal-01413614v1>

Preprint submitted on 10 Dec 2016 (v1), last revised 30 Jan 2020 (v3)

HAL is a multi-disciplinary open access archive for the deposit and dissemination of scientific research documents, whether they are published or not. The documents may come from teaching and research institutions in France or abroad, or from public or private research centers.

L'archive ouverte pluridisciplinaire **HAL**, est destinée au dépôt et à la diffusion de documents scientifiques de niveau recherche, publiés ou non, émanant des établissements d'enseignement et de recherche français ou étrangers, des laboratoires publics ou privés.

REVERSAL PROPERTIES AND EXACT SIMULATION OF THE GENEALOGICAL TREE FOR A STATIONNARY BRANCHING POPULATION

ROMAIN ABRAHAM AND JEAN-FRANÇOIS DELMAS

ABSTRACT. We consider a model of stationary population with random size given by a stationary continuous state branching process with a quadratic branching mechanism. We give an exact elementary simulation procedure of the genealogical tree of n individuals randomly chosen among the extant population at a given time. Then, we prove the convergence of the renormalized total length of this genealogical tree as n goes to infinity, see also Pfaffelhuber, Wakolbinger and Weisshaupt (2011) in the context of a constant size population. The proof is based on the ancestral process of the extant population at a fixed time which was defined by Aldous and Popovic (2005) in the critical case. We also present a reversal procedure on the genealogical tree of the whole population that consists in looking at the tree downward from its tip: the branching points becoming leaves and leaves becoming branching points. We prove that the distribution of the genealogical tree is invariant under this reversal procedure, which provides a better understanding of previous results from Bi and Delmas (2016).

1. INTRODUCTION

Continuous state branching (CB) processes are stochastic processes that can be obtained as the scaling limits of sequences of Galton-Watson processes when the initial number of individuals tends to infinity. They hence can be seen as a model for a large branching population. The genealogical structure of a CB process can be described by a continuum random tree introduced first by Aldous [3] for the quadratic critical case, see also Le Gall and Le Jan [19] and Duquesne and Le Gall [12] for the general critical and sub-critical cases. We shall only consider the quadratic case; it is characterized by a branching mechanism ψ_θ :

$$\psi_\theta(\lambda) = \beta\lambda^2 + 2\beta\theta\lambda, \quad \lambda \in [0, +\infty),$$

where $\beta > 0$ and $\theta \in \mathbb{R}$. The sub-critical (resp. critical) case corresponds to $\theta > 0$ (resp. $\theta = 0$). The parameter β can be seen as a time scaling parameter, and θ as a population size parameter.

In this model the population dies out a.s. in the critical and sub-critical cases. In order to model branching population with stationary size distribution, which corresponds to what is observed at an ecological equilibrium, one can simply condition a sub-critical or a critical CB to not die out. This gives a Q-process, see Roelly-Coppoleta and Rouault [24] and Lambert [18], which can also be viewed as a CB with a specific immigration. The genealogical structure of the Q-process in the stationary regime is a tree with an infinite spine. This infinite spine has to be removed if one adopts the immigration point of view, in this case the genealogical structure can be seen as a forest of trees. For $\theta > 0$, let $(Z_t, t \in \mathbb{R})$ be this Q-process in the stationary regime, so that Z_t is the size of the population at time $t \in \mathbb{R}$. See Chen and Delmas [8] for studies on this model in a more general framework. Let A_t be the time to the most recent common ancestor

Date: December 10, 2016.

2010 Mathematics Subject Classification. 60J80,60J85.

Key words and phrases. Stationary branching processes, Real trees, Genealogical trees, Ancestral process, Simulation.

of the population living at time t , see (12) for a precise definition. According to [8], we have $\mathbb{E}[Z_t] = 1/\theta$, and $\mathbb{E}[A_t] = 3/4\beta\theta$, so that θ is indeed a population size parameter and β is a time parameter.

For $s < t$, let M_s^t be the number of ancestors at time s of the population living at time t , the individual in the infinite lineage being excluded, see Section 3.4 for a precise definition. Notice that M_s^t can also be seen as the number of individuals at time s who have descendants at time t . It is proven in Bi and Delmas [5], that for fixed $\theta > 0$ a time reversal property holds: the ancestor process $((M_{s-r}^s, r > 0), s \in \mathbb{R})$ is distributed as the descendant process $((M_s^{s+r}, r > 0), s \in \mathbb{R})$. The first result of this paper, see Corollary 3.12 extends and explains this identity in law by reversing the genealogical tree. The idea is to see the tree as ranked branches, with each branch being attached to a longer one (the longest being the infinite spine). Then, re-attach every branch by its highest point on the same branch. Hence, branching points become leaves and leaves become branching points. Call this operation the reversal procedure. Corollary 3.12 states that, for $\theta \geq 0$, the distribution of the genealogical structure of the Q-process in the stationary regime is invariant by the reversal procedure. See a similar result in the discrete setting of splitting trees in Dávila Felipe and Lambert [9].

Aldous and Popovic [4], see also Popovic [23], give a description of the genealogical tree of the extant population at a fixed time using the so-called ancestral process which is a point process representation of the lineage in a setting very close to $\theta = 0$ in the present model. We extend the presentation of [4] to the case $\theta \geq 0$, see Propositions 4.6 and 4.8 which can be summarized as follows. According to [8], Z_t is distributed as $E_g + E_d$, where E_g and E_d are two independent exponential random variables with mean $1/2\theta$ (take $E_g = E_d = +\infty$ if $\theta = 0$). Conditionally given (E_g, E_d) , let $\mathcal{A}(du, d\zeta) = \sum_{i \in \mathcal{I}} \delta_{u_i, \zeta_i}(du, d\zeta)$ be a Poisson point measure with intensity:

$$\mathbf{1}_{(-E_g, E_d)}(u) du |c'_\theta(\zeta)| d\zeta,$$

where c_θ is defined by (5). Then individuals of the population at time t (with total size Z_t) can be identified in distribution with the interval $(-E_g, E_d)$ and their genealogy is described by the genealogical distance d defined by $d(x, y) = 2 \max\{\zeta_i, u_i \in J(x, y)\}$, where $J(x, y) = (x, y]$ (resp. $[x, y)$ and resp. $[x, y]$) if $x \geq 0$ (resp. $y \leq 0$ and resp. $y \leq 0$).

The ancestral process description allows to give elementary exact simulations of the genealogical tree of n individuals randomly chosen in the extant population at some time $t \in \mathbb{R}$. We give first a static simulation for fixed n in Subsection 5.1, then two dynamic simulations in Subsections 5.2 and 5.3, where the individuals are taken one by one and the genealogical tree is then updated. Our framework allows also to simulate the genealogical tree of n extant individuals conditionally given the time A_t to the most recent common ancestor of the extant population, see Subsection 5.4. Let us stress that the existence of an elementary simulation method is new, and the question goes back to Lambert [17] and Theorem 4.7 in [8].

The ancestral process description allows also to compute the limit distribution of the total length of the genealogical tree of the extant population at time $t \in \mathbb{R}$. More precisely, let Λ_n be the total length of the tree of n individuals randomly chosen in the extant population at time $t \in \mathbb{R}$, see (15) for a precise definition. Then we prove, see Proposition 3.13 and (36), that $(\Lambda_n - \mathbb{E}[\Lambda_n | Z_t], n \in \mathbb{N}^*)$ converges a.s. and in L^2 as n goes down to 0 towards \mathcal{L}_t . The Laplace

transform of the distribution of $\mathcal{L}_{(t)}$ is given by, for $\lambda > 0$:

$$\mathbb{E} \left[e^{-\lambda \mathcal{L}_t} | Z_t \right] = e^{\theta Z_t \varphi(\lambda/(2\beta\theta))}, \quad \text{with} \quad \varphi(\lambda) = \lambda \int_0^1 \frac{1-v^\lambda}{1-v} dv.$$

The proof is based on technical L^2 computations. This result is in the spirit of Pfaffelhuber, Wakolbinger and Weisshaupt [22] on the tree length of the coalescent, which is a model for constant population size. We also prove that \mathcal{L}_t coincides with the limit of $L_\varepsilon = \int_\varepsilon^\infty M_{t-s}^t ds$, the total length of the genealogical tree up to $t - \varepsilon$ of the individuals at time t obtained in [5]. More precisely, we have that $(L_\varepsilon - \mathbb{E}[L_\varepsilon | Z_0], \varepsilon > 0)$ converges a.s. towards \mathcal{L}_t as ε goes down to zero. See [5] for some properties of the process $(\mathcal{L}_t, t \in \mathbb{R})$.

The paper is organized as follows. We first introduce in Section 2 the framework of real trees and we define the Brownian CRT that describes the genealogy of the CB in the quadratic case. We define in Section 3 the reversal procedure of a tree and prove the invariance property of the Brownian CRT under this reversal procedure. We then extend the result to the Brownian forest that describes the genealogy of the stationary population in the quadratic (critical and sub-critical) case. We also state in this section the result concerning the length of the genealogical tree of the extant population at time 0 but we postpone its proof in Section 6 as it requires the results of the three next sections. Section 4 is devoted to the description via a Poisson point measure of the ancestral process of the extant population at time 0 and Section 5 gives the different simulations of the genealogical tree of n individuals randomly chosen in the population at time 0.

2. NOTATIONS

2.1. Real trees. The study of real trees has been motivated by algebraic and geometric purposes. See in particular the survey [10]. It has been first used in [15] to study random continuum trees, see also [14].

Definition 2.1 (Real tree). *A real tree is a metric space $(\mathbf{t}, d_{\mathbf{t}})$ such that*

- (i) *For every $x, y \in \mathbf{t}$, there is a unique isometric map $f_{x,y}$ from $[0, d_{\mathbf{t}}(x, y)]$ to \mathbf{t} such that $f_{x,y}(0) = x$ and $f_{x,y}(d_{\mathbf{t}}(x, y)) = y$.*
- (ii) *For every $x, y \in \mathbf{t}$, if ϕ is a continuous injective map from $[0, 1]$ to \mathbf{t} such that $\phi(0) = x$ and $\phi(1) = y$, then $\phi([0, 1]) = f_{x,y}([0; d_{\mathbf{t}}(x, y)])$.*

Notice that a real tree is a length space as defined in [7]. We say that a real tree is *rooted* if there is a distinguished vertex ∂ which we call the root. We denote by \mathcal{T} the set of compact rooted real trees. Remark that the set $\{\partial\}$ is a rooted tree that only contains the root.

Let $\mathbf{t} \in \mathcal{T}$ and two vertices $x, y \in \mathbf{t}$. We denote by $\llbracket x, y \rrbracket$ the range of the map $f_{x,y}$ described in Definition 2.1. We also set $\llbracket x, y \rrbracket = \llbracket x, y \rrbracket \setminus \{y\}$. We define the out-degree of x , denoted by $k_{\mathbf{t}}(x)$, as the number of connected components of $\mathbf{t} \setminus \{x\}$ that do not contain the root. If $k_{\mathbf{t}}(x) = 0$, resp. $k_{\mathbf{t}}(x) > 1$, then x is called a leaf, resp. a branching point. We denote by $\mathcal{L}(\mathbf{t})$, resp. $\mathcal{B}(\mathbf{t})$, the set of leaves, resp. of branching points, of \mathbf{t} . A tree is said to be binary if the out-degree of its vertices belongs to $\{0, 1, 2\}$. The skeleton of the tree \mathbf{t} is the set of points of \mathbf{t} that are not leaves: $\text{sk}(\mathbf{t}) = \mathbf{t} \setminus \mathcal{L}(\mathbf{t})$. Notice that $\text{cl}(\text{sk}(\mathbf{t})) = \mathbf{t}$, where $\text{cl}(A)$ denote the closure of A .

We denote by \mathbf{t}_x the sub-tree of \mathbf{t} above x i.e.

$$\mathbf{t}_x = \{y \in \mathbf{t}, x \in \llbracket \partial, y \rrbracket\}$$

rooted at x . We say that x is an ancestor of y , which we denote by $x \preceq y$, if $y \in \mathbf{t}_x$. We write $x \prec y$ if furthermore $x \neq y$. Notice that \preceq is a partial order on \mathbf{t} . We denote by $x \wedge y$ the

Most Recent Common Ancestor (MRCA) of x and y in \mathbf{t} i.e. the unique vertex of \mathbf{t} such that $[[\partial, x]] \cap [[\partial, y]] = [[\partial, x \wedge y]]$.

We denote by $h_{\mathbf{t}}(x) = d_{\mathbf{t}}(\partial, x)$ the height of the vertex x in the tree \mathbf{t} and by $H(\mathbf{t})$ the height of the tree \mathbf{t} :

$$H(\mathbf{t}) = \max\{h_{\mathbf{t}}(x), x \in \mathbf{t}\}.$$

We define the set of extremal leaves of \mathbf{t} by:

$$\mathcal{L}^*(\mathbf{t}) = \{y \in \mathcal{L}(\mathbf{t}), \exists x \in \mathbf{t} \text{ s.t. } x \prec y \text{ and } h_{\mathbf{t}_x}(y) = H(\mathbf{t}_x)\}.$$

In particular, we can have $\mathcal{L}^*(\mathbf{t}) \neq \mathcal{L}(\mathbf{t})$, see the example at the end of this subsection.

For $\varepsilon > 0$, we define the erased tree $r_{\varepsilon}(\mathbf{t})$ (sometimes called in the literature the ε -trimming of the tree \mathbf{t}) by

$$r_{\varepsilon}(\mathbf{t}) = \{x \in \mathbf{t}, H(\mathbf{t}_x) \geq \varepsilon\}.$$

For $\varepsilon \in (0, H(\mathbf{t}))$, $r_{\varepsilon}(\mathbf{t})$ is indeed a tree and $r_{\varepsilon}(\mathbf{t}) = \emptyset$ for $\varepsilon > H(\mathbf{t})$. Notice that

$$(1) \quad \bigcup_{\varepsilon > 0} r_{\varepsilon}(\mathbf{t}) = \text{sk}(\mathbf{t}).$$

Definition 2.2 (Height regular). *We say that a tree $\mathbf{t} \in \mathcal{T}$ is height-regular if, for every $\varepsilon > 0$, for every $(x, y) \in \mathcal{L}(r_{\varepsilon}(\mathbf{t}))^2 \cup \mathcal{B}(r_{\varepsilon}(\mathbf{t}))^2$,*

$$x \neq y \implies h_{\mathbf{t}}(x) \neq h_{\mathbf{t}}(y).$$

We denote by \mathcal{T}_0 the set of rooted real trees which are compact, height-regular and binary.

Lemma 2.3. *Let \mathbf{t} be a compact height-regular tree. For every $x \in \mathbf{t}$, there exists a unique $x_{\mathbf{t}}^* \in \mathbf{t}_x$ (or simply x^* when there is no risk of confusion) such that*

$$h_{\mathbf{t}_x}(x_{\mathbf{t}}^*) = H(\mathbf{t}_x).$$

Proof. If $x \in \mathcal{L}(\mathbf{t})$, then $\mathbf{t}_x = \{x\}$ and the lemma holds trivially.

Let $x \in \text{sk}(\mathbf{t})$. First, as \mathbf{t}_x is compact, $H(\mathbf{t}_x)$ is finite and there exists at least one point $y \in \mathbf{t}_x$ such that $h_{\mathbf{t}_x}(y) = H(\mathbf{t}_x)$.

Assume there exists two distinct points $y, y' \in \mathbf{t}_x$ such that $h_{\mathbf{t}_x}(y) = h_{\mathbf{t}_x}(y') = H(\mathbf{t}_x)$. Then we have $y \wedge y' \in \mathbf{t}_x$ and $h_{\mathbf{t}_x}(y \wedge y') < H(\mathbf{t}_x)$. We choose $\varepsilon > 0$ such that $\varepsilon < H(\mathbf{t}_x) - h_{\mathbf{t}_x}(y \wedge y')$ and we denote by y_{ε} (resp. y'_{ε}) the unique point in $[[y \wedge y', y]]$ (resp. $[[y \wedge y', y']])$ such that $d_{\mathbf{t}}(y_{\varepsilon}, y) = \varepsilon$ (resp. $d_{\mathbf{t}}(y'_{\varepsilon}, y') = \varepsilon$). Remark that these points exist by the particular choice of ε . Then, by definition, y_{ε} and y'_{ε} are distinct leaves of $r_{\varepsilon}(\mathbf{t})$ and have the same height, which contradicts the fact that \mathbf{t} is height regular. \square

Let $\mathbf{t} \in \mathcal{T}_0$. For $x \in \mathbf{t}$, the vertex x^* will be called the tip of the tree \mathbf{t}_x . For such a tree, we have the equality:

$$\mathcal{L}^*(\mathbf{t}) = \{x^*, x \in \text{sk}(\mathbf{t})\}.$$

For every $x \in \mathbf{t}$, we define the branching point of x on $[[\partial, \partial^*]]$ as

$$\underline{x} = x \wedge \partial^*.$$

For every $y \in [[\partial, \partial^*]]$, the sub-tree (possibly reduced to its root) rooted at y which does not contain neither ∂ nor ∂^* is given by

$$\tilde{\mathbf{t}}_y = \{z \in \mathbf{t}, z \wedge \partial^* = y\}.$$

Notice that $\tilde{\mathbf{t}}_y$ is indeed a tree. Then, for every $x \in \mathbf{t}$, we define the maximal height of the subtree $\tilde{\mathbf{t}}_{\underline{x}}$ which is attached on $[[\partial, \partial^*]]$ and which contains x by

$$h'_{\mathbf{t}}(x) = H(\tilde{\mathbf{t}}_{\underline{x}}) + h_{\mathbf{t}}(\underline{x}).$$

See Figure 1 for a simplified picture of \underline{x} , x^* , $\tilde{\mathbf{t}}_{\underline{x}}$ and $h'_{\mathbf{t}}(x)$.

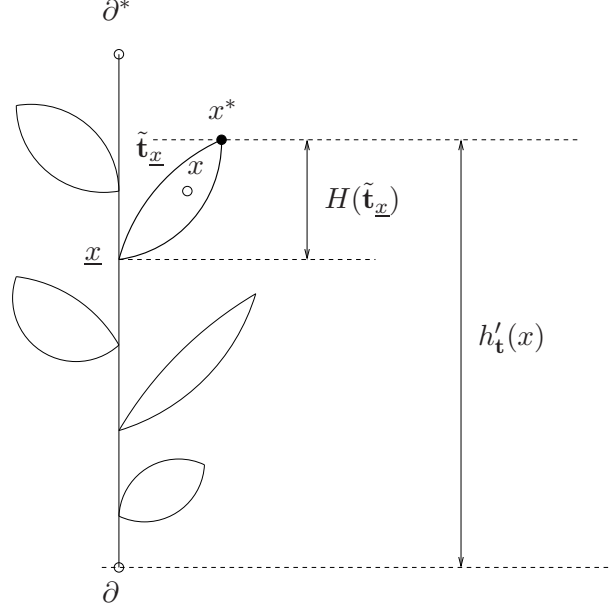

FIGURE 1. A tree \mathbf{t} and a subtree $\tilde{\mathbf{t}}_{\underline{x}}$

Let $\mathbf{t} \in \mathcal{T}$ and let $(\mathbf{t}_i, i \in I)$, $(x_i, i \in I)$ be families of trees and vertices of \mathbf{t} respectively. We denote by $\mathbf{t}_i^\circ = \mathbf{t}_i \setminus \{\partial_{\mathbf{t}_i}\}$. We define the tree $\mathbf{t} \otimes_{i \in I} (\mathbf{t}_i, x_i)$ obtained by grafting the trees \mathbf{t}_i on the tree \mathbf{t} at points x_i by

$$\mathbf{t} \otimes_{i \in I} (\mathbf{t}_i, x_i) = \mathbf{t} \sqcup \left(\bigsqcup_{i \in I} \mathbf{t}_i^\circ \right),$$

$$d_{\mathbf{t} \otimes_{i \in I} (\mathbf{t}_i, x_i)}(y, y') = \begin{cases} d_{\mathbf{t}}(y, y') & \text{if } y, y' \in \mathbf{t}, \\ d_{\mathbf{t}_i}(y, y') & \text{if } y, y' \in \mathbf{t}_i^\circ, \\ d_{\mathbf{t}}(y, x_i) + d_{\mathbf{t}_i}(\partial_{\mathbf{t}_i}, y') & \text{if } y \in \mathbf{t} \text{ and } y' \in \mathbf{t}_i^\circ, \\ d_{\mathbf{t}_i}(y, \partial_{\mathbf{t}_i}) + d_{\mathbf{t}}(x_i, x_j) + d_{\mathbf{t}_j}(\partial_{\mathbf{t}_j}, y') & \text{if } y \in \mathbf{t}_i^\circ \text{ and } y' \in \mathbf{t}_j^\circ \text{ with } i \neq j, \end{cases}$$

$$\partial_{\mathbf{t} \otimes_{i \in I} (\mathbf{t}_i, x_i)} = \partial_{\mathbf{t}},$$

where $A \sqcup B$ denotes the disjoint union of the sets A and B . Notice that $\mathbf{t} \otimes_{i \in I} (\mathbf{t}_i, x_i)$ might not be compact and thus might not belong to \mathcal{T} .

Let us finish with an instance of a tree \mathbf{t} such that $\mathcal{L}^*(\mathbf{t}) \neq \mathcal{L}(\mathbf{t})$. For every positive integer n , let us set $\mathbf{t}_n = [0, 1/n] \subset \mathbb{R}$, viewed as a rooted real tree when endowed with the usual distance on the real line and rooted at 0. We consider the tree

$$\mathbf{t} = \mathbf{t}_1 \otimes_{n \geq 2} (\mathbf{t}_n, 1 - \frac{1}{n^2}).$$

Then \mathbf{t} is a compact height-regular tree and $1 \in \mathbf{t}_1$ is a leaf of \mathbf{t} that does not belong to $\mathcal{L}^*(\mathbf{t})$.

2.2. The Gromov-Hausdorff topology. In order to define random real trees, we endow the set of rooted compact real trees \mathcal{T} with a metric, the so-called Gromov-Hausdorff metric, which hence defines a Borel σ -algebra on \mathcal{T} .

First, let us recall the definition of the Hausdorff distance between two compact subsets: let A, B be two compact subsets of a metric space (X, d_X) . For every $\varepsilon > 0$, we set:

$$A^\varepsilon = \{x \in X, d_X(x, A) \leq \varepsilon\}.$$

Then, the Hausdorff distance between A and B is defined by:

$$d_{X, \text{Haus}}(A, B) = \inf\{\varepsilon > 0, B \subset A^\varepsilon \text{ and } A \subset B^\varepsilon\}.$$

Now, let $(\mathbf{t}, d_{\mathbf{t}}, \partial_{\mathbf{t}})$, $(\mathbf{t}', d_{\mathbf{t}'}, \partial_{\mathbf{t}'})$ be two compact rooted real trees. We define the pointed Gromov-Hausdorff distance between them (see [16, 15]) by:

$$d_{GH}(\mathbf{t}, \mathbf{t}') = \inf\{d_{Z, \text{Haus}}(\varphi(\mathbf{t}), \varphi'(\mathbf{t}')) \vee d_Z(\varphi(\partial_{\mathbf{t}}), \varphi'(\partial_{\mathbf{t}'}))\},$$

where the infimum is taken over all metric spaces (Z, d_Z) and all isometric embeddings $\varphi : \mathbf{t} \rightarrow Z$ and $\varphi' : \mathbf{t}' \rightarrow Z$.

Notice that d_{GH} is only a pseudo-metric on \mathcal{T} . We say that two rooted real trees \mathbf{t} and \mathbf{t}' are equivalent (and we note $\mathbf{t} \sim \mathbf{t}'$) if there exists a root-preserving isometry that maps \mathbf{t} onto \mathbf{t}' , that is $d_{GH}(\mathbf{t}, \mathbf{t}') = 0$. This clearly defines an equivalence relation on \mathcal{T} . We denote by \mathbb{T} (resp. \mathbb{T}_0) the set of equivalence classes of \mathcal{T} (resp. \mathcal{T}_0). The Gromov-Hausdorff distance d_{GH} hence induces a distance on \mathbb{T} (that is still denoted by d_{GH}). Moreover, the metric space (\mathbb{T}, d_{GH}) is complete and separable (see [15]). We denote by π the canonical projection from \mathcal{T} on \mathbb{T} .

It is easy to check that, for $\mathbf{t}, \mathbf{t}' \in \mathcal{T}$, if $\mathbf{t} \sim \mathbf{t}'$, then, for every $\varepsilon > 0$, $r_\varepsilon(\mathbf{t}) \sim r_\varepsilon(\mathbf{t}')$ so the erasure operator r_ε is well-defined on \mathbb{T} .

2.3. Coding a compact real tree by a function and the Brownian CRT. Let \mathcal{E} be the set of continuous function $g : [0, +\infty) \rightarrow [0, +\infty)$ with compact support and such that $g(0) = 0$. For $g \in \mathcal{E}$, we set $\sigma(g) = \sup\{x, g(x) > 0\}$. Let $g \in \mathcal{E}$, and assume that $\sigma(g) > 0$, that is g is not identically zero. For every $s, t \geq 0$, we set

$$m_g(s, t) = \inf_{r \in [s \wedge t, s \vee t]} g(r),$$

and

$$(2) \quad d_g(s, t) = g(s) + g(t) - 2m_g(s, t).$$

It is easy to check that d_g is a pseudo-metric on $[0, +\infty)$. We then say that s and t are equivalent iff $d_g(s, t) = 0$ and we set T_g the associated quotient space. We keep the notation d_g for the induced distance on T_g . Then the metric space (T_g, d_g) is a compact real-tree (see [13]). We denote by p_g the canonical projection from $[0, +\infty)$ to T_g . We will view (T_g, d_g) as a rooted real tree with root $\partial = p_g(0)$. We will call (T_g, d_g) the real tree coded by g , and conversely that g is a contour function of the tree T_g . We denote by F the application $g \mapsto T_g$.

Conversely every rooted compact real tree (T, d) can be coded by a continuous function g (up to a root-preserving isometry), see [11].

Let $\theta \in \mathbb{R}$, $\beta > 0$ and $B^{(\theta)} = (B_t^{(\theta)}, t \geq 0)$ be a Brownian motion with drift -2θ and scale $\sqrt{2/\beta}$: for $t \geq 0$,

$$B_t^{(\theta)} = \sqrt{2/\beta} B_t - 2\theta t,$$

where B is a standard Brownian motion. For $\theta \geq 0$, let $n^{(\theta)}[de]$ denote the Itô measure on \mathcal{E} of positive excursions of $B^{(\theta)}$ normalized such that for $\lambda \geq 0$:

$$(3) \quad n^{(\theta)} \left[1 - e^{-\lambda \sigma} \right] = \psi_\theta^{-1}(\lambda),$$

where $\sigma = \sigma(e)$ denotes the duration (or the length) of the excursion e and for $\lambda \geq 0$:

$$(4) \quad \psi_\theta(\lambda) = \beta\lambda^2 + 2\beta\theta\lambda.$$

Let $\zeta = \zeta(e) = \max_{s \in [0, \sigma]}(e_s)$ be the maximum of the excursion. We set $c_\theta(h) = n^{(\theta)}[\zeta \geq h]$ for $h > 0$, and we recall that:

$$(5) \quad c_\theta(h) = \begin{cases} (\beta h)^{-1} & \text{if } \theta = 0, \\ 2\theta (e^{2\beta\theta h} - 1)^{-1} & \text{if } \theta > 0. \end{cases}$$

We define the Brownian Continuum Random Tree (CRT for short), $\tau = \pi \circ F(e)$, as the tree coded by the positive excursion e under $n^{(\theta)}$. And we define the measure $\mathbb{N}^{(\theta)}$ on \mathbb{T} as the ‘‘distribution’’ of τ , that is the push-forward of the measure $n^{(\theta)}$ by the application $\pi \circ F$. Notice that $H(\tau) = \zeta(e)$.

Remark 2.4. If we translate the former construction into the framework of [12], then, for $\theta \geq 0$, $B^{(\theta)}$ is the height process which codes the Brownian CRT with branching mechanism ψ_θ and it is obtained from the underlying Lévy process $X = (X_t, t \geq 0)$ with $X_t = \sqrt{2\beta} B_t - 2\beta\theta t$.

Let e with ‘‘distribution’’ $n^{(\theta)}(de)$ and let $(\Lambda_s^a, s \geq 0, a \geq 0)$ be the local time of e at time s and level a . Then we define the local time measure of τ at level $a \geq 0$, denoted by $\ell_a(dx)$, as the push-forward of the measure $d\Lambda_s^a$ by the map $\pi \circ F$, see Theorem 4.2 in [13]. We shall define ℓ_a for $a \in \mathbb{R}$ by setting $\ell_a = 0$ for $a \in \mathbb{R} \setminus [0, H(\tau)]$.

2.4. Forests.

2.4.1. *Definitions.* A forest \mathbf{f} is a family $((h_i, \mathbf{t}_i), i \in I)$ of points of $\mathbb{R} \times \mathcal{T}$. Using an immediate extension of the grafting procedure, for an interval $\mathfrak{J} \subset \mathbb{R}$, we define the real tree $\mathbf{f}_{\mathfrak{J}} = \mathfrak{J} \oplus_{i \in I, h_i \in \mathfrak{J}} (\mathbf{t}_i, h_i)$. For $\mathfrak{J} = \mathbb{R}$, $\mathbf{f}_{\mathbb{R}}$ is an infinite spine (the real line) on which we graft the compact trees \mathbf{t}_i at the points h_i respectively. We shall identify the forest \mathbf{f} with $\mathbf{f}_{\mathbb{R}}$ when the $(h_i, i \in I)$ are pairwise distinct.

Let us denote, for $i \in I$, by d_i the distance of the tree \mathbf{t}_i and by $\mathbf{t}_i^\circ = \mathbf{t}_i \setminus \{\partial \mathbf{t}_i\}$ the tree \mathbf{t}_i without its root. The distance on $\mathbf{f}_{\mathfrak{J}}$ is then defined, for $x, y \in \mathbf{f}_{\mathfrak{J}}$, by:

$$d_{\mathbf{f}}(x, y) = \begin{cases} d_i(x, y) & \text{if } x, y \in \mathbf{t}_i^\circ, \\ h_{\mathbf{t}_i}(x) + |h_i - h_j| + h_{\mathbf{t}_j}(y) & \text{if } x \in \mathbf{t}_i^\circ, y \in \mathbf{t}_j^\circ \text{ with } i \neq j, \\ |x - h_j| + h_{\mathbf{t}_j}(y) & \text{if } x \notin \bigcup_{i \in I} \mathbf{t}_i^\circ, y \in \mathbf{t}_j^\circ \\ |x - y| & \text{if } x, y \notin \bigcup_{i \in I} \mathbf{t}_i^\circ. \end{cases}$$

Lemma 2.5. *Let $\mathfrak{J} \subset \mathbb{R}$ be a closed interval. If for every $a, b \in \mathfrak{J}$, such that $a < b$, and every $\varepsilon > 0$, the set $\{i \in I, h_i \in [a, b], H(\mathbf{t}_i) > \varepsilon\}$ is finite, then the tree $\mathbf{f}_{\mathfrak{J}}$ is a complete locally compact length space.*

Proof. Let $(x_n, n \geq 0)$ be a bounded sequence of $\mathbf{f}_{\mathfrak{J}}$. If there exists a sub-sequence $(x_{n_k}, k \leq 0)$ which belongs to \mathfrak{J} (resp. to \mathbf{t}_i° for some $i \in I$), then as \mathfrak{J} is a closed interval (resp. $\mathbf{t}_i^\circ \cup \{h_i\}$ is compact), this sub-sequence admits at least one accumulation point.

If this is not the case, without loss of generality, we can suppose that $x_n \in \mathbf{t}_{i_n}^\circ$ with pairwise distinct indices i_n . Notice that the sequence $(h_{i_n}, n \geq 0)$ of elements of \mathfrak{J} is bounded, since $d_{\mathbf{f}}(h_{i_0}, h_{i_n}) \leq d_{\mathbf{f}}(x_0, x_n)$. Therefore, as \mathfrak{J} is a closed interval, there exists a converging sub-sequence $(h_{i_{n_k}}, k \geq 0)$. Let us denote by $h \in \mathfrak{J}$ its limit. Moreover, using the assumption that $\{i \in I, h_i \in [a, b], H(\mathbf{t}_i) > \varepsilon\}$ is finite for all $a < b$, we have $\lim_{n \rightarrow +\infty} d_{\mathbf{f}}(x_n, h_{i_n}) = 0$. Therefore, the sub-sequence $(x_{n_k}, k \geq 0)$ converges to h .

In conclusion, we get that every bounded sequence of \mathbf{f}_j admits at least one accumulation point. This implies that \mathbf{f}_j is complete and locally compact. It is also a length space as it is a tree. \square

2.4.2. Trees with one semi-infinite branch. Let $(\mathbf{t}, d_{\mathbf{t}}, \rho_0)$ be a rooted real tree. We shall mainly consider unbounded trees in this section with ρ_0 viewed as a leaf. We denote by $\mathcal{S}(\mathbf{t})$ the set of vertices $x \in \mathbf{t}$ such that at least one of the connected components of $\mathbf{t} \setminus \{x\}$ that do not contain ρ_0 is unbounded. If $\mathcal{S}(\mathbf{t})$ is not empty, then it is a tree which contains ρ_0 . We say that \mathbf{t} has a unique semi-infinite branch if $\mathcal{S}(\mathbf{t})$ is non-empty and has no branching point. For instance, the tree $\mathbf{f}_{(-\infty, h]}$ associated with some forest \mathbf{f} and $h \in \mathbb{R}$ has a unique semi-infinite branch, whatever the choice of the root is.

We define \mathcal{T}_1 the set of quadruplets $(\mathbf{t}, d_{\mathbf{t}}, \rho_0, h_0)$ where $(\mathbf{t}, d_{\mathbf{t}}, \rho_0)$ is a complete locally compact rooted real tree with a unique semi-infinite branch, and $h_0 \in \mathbb{R}$. The real number h_0 will be seen as the height of ρ_0 . When there is no risk of confusion, we write \mathbf{t} for $(\mathbf{t}, d_{\mathbf{t}}, \rho_0, h_0)$. The next corollary, which provides natural generic elements of \mathcal{T}_1 , is an elementary consequence of Lemma 2.5.

Corollary 2.6. *Let $\mathbf{f} = ((h_i, \mathbf{t}_i), i \in I)$ be a forest such that for every $a < b$, and every $\varepsilon > 0$, the set $\{i \in I, h_i \in [a, b], H(\mathbf{t}_i) > \varepsilon\}$ is finite. Then, the quadruplet $(\mathbf{f}_{(-\infty, h_0]}, d_{\mathbf{f}}, h_0, h_0)$ belongs to \mathcal{T}_1 for any $h \in \mathbb{R}$.*

We say that $(\mathbf{t}, d_{\mathbf{t}}, \rho_0, h_0)$ and $(\mathbf{t}', d'_{\mathbf{t}}, \rho'_0, h'_0)$, elements of \mathcal{T}_1 , are equivalent if there is an isometry ϕ between $(\mathbf{t}, d_{\mathbf{t}})$ and $(\mathbf{t}', d'_{\mathbf{t}})$ such that $\phi(\rho_0) = \rho'_0$ and furthermore $h_0 = h'_0$. Let \mathbb{T}_1 be the set equivalence classes of elements of \mathcal{T}_1 . We can follow [2] to endow \mathbb{T}_1 with a Gromov-Hausdorff-type distance for which \mathbb{T}_1 is a Polish space.

We shall identify a tree $(\mathbf{t}, d_{\mathbf{t}}, \rho_0, h_0) \in \mathcal{T}_1$ with a forest. We set $(\mathbf{t}_i^0, i \in I)$ the connected components of $\mathbf{t} \setminus \mathcal{S}(\mathbf{t})$. For every $i \in I$, we set x_i the unique point of $\mathcal{S}(\mathbf{t})$ such that $\inf\{d_{\mathbf{t}}(x_i, y), y \in \mathbf{t}_i^0\} = 0$, and:

$$\mathbf{t}_i = \mathbf{t}_i^0 \cup \{x_i\}, \quad h_i = h_0 - d(\rho_0, x_i).$$

We shall say that x_i is the root of \mathbf{t}_i . Notice that $(\mathbf{t}_i, d_{\mathbf{t}}, x_i)$ is a bounded rooted tree. It is also compact since, according to the Hopf-Rinow theorem (see Theorem 2.5.26 in [7]), it is a bounded closed subset of a complete locally compact length space. Thus it belongs to \mathcal{T} . In particular the family $\mathbf{f} = ((h_i, \mathbf{t}_i), i \in I)$ is a forest. We shall also consider $h_0 \in (-\infty, h_0]$ as an element of the tree $\mathbf{f}_{(-\infty, h_0]}$. It is then easy to check that $(\mathbf{f}_{(-\infty, h_0]}, d_{\mathbf{f}}, h_0, h_0)$ and $(\mathbf{t}, d_{\mathbf{t}}, \rho_0, h_0)$ are equivalent. Thus $\mathbf{f}_{(-\infty, h_0]}$ and \mathbf{t} belong to the same equivalence class in \mathbb{T}_1 .

We extend the partial order defined for trees in \mathcal{T} to trees elements in \mathcal{T}_1 , with the idea that ρ_0 is at the tip of the semi-infinite branch. Let $(\mathbf{t}, d_{\mathbf{t}}, \rho_0, h_0) \in \mathcal{T}_1$ and $x, y \in \mathbf{t}$. We use the decomposition of \mathbf{t} as a forest from the previous paragraph. We set $x \preceq y$ if either $x, y \in \mathcal{S}(\mathbf{t})$ and $d(x, \rho_0) \geq d(y, \rho_0)$, or $x, y \in \mathbf{t}_i$ for some $i \in I$ and $x \preceq y$ (with the partial order for the rooted compact real tree $(\mathbf{t}_i, d_{\mathbf{t}}, x_i)$ defined in Section 2.1), or $x \in \mathcal{S}(\mathbf{t})$ and $y \in \mathbf{t}_i$ for some $i \in I$ and $x \preceq x_i$. We write $x \prec y$ if furthermore $x \neq y$. We define $x \wedge y$ the MRCA of $x, y \in \mathbf{t}$ as $x \preceq y$, as $x \wedge y$ if $x, y \in \mathbf{t}_i$ for some $i \in I$ (with the MRCA for the rooted compact real tree $(\mathbf{t}_i, d_{\mathbf{t}}, x_i)$ defined in Section 2.1), as $x_i \wedge x_j$ if $x \in \mathbf{t}_i$ and $y \in \mathbf{t}_j$ for some $i \neq j$. We define the height of a vertex $x \in \mathbf{t}$ as

$$h_{\mathbf{t}}(x) = h_0 - d_{\mathbf{t}}(\rho_0, \rho_0 \wedge x) + d_{\mathbf{t}}(x, \rho_0 \wedge x).$$

Notice that the definition of the height for a tree $(\mathbf{t}, d_{\mathbf{t}}, \rho_0, h_0) \in \mathcal{T}_1$ is different than the height of a tree in \mathcal{T} , as in the former case the root ρ_0 is viewed as a distinguished vertex at height h_0 and above the semi-infinite branch.

2.4.3. Coding a forest by a contour function. We want to extend the construction of a tree of the type $\mathbf{f}_{(-\infty, h]}$ via a contour function as in Section 2.3. Let \mathcal{E}_1 be the set of continuous functions g defined on \mathbb{R} such that $\liminf_{x \rightarrow -\infty} g(x) = \liminf_{x \rightarrow +\infty} g(x) = -\infty$. For such a function, we still consider the pseudo-metric d_g defined by (2) (but for $s, t \in \mathbb{R}$) and define the tree T_g as the quotient space on \mathbb{R} induced by this pseudo-metric. We set p_g as the canonical projection from \mathbb{R} onto T_g .

Lemma 2.7. *Let $g \in \mathcal{E}_1$. The quadruplet $(T_g, d_g, p_g(0), g(0))$ belongs to \mathcal{T}_1 .*

Proof. We define the infimum function $\underline{g}(x)$ on \mathbb{R} as the infimum of g between 0 and x : $\underline{g}(x) = \inf_{[x \wedge 0, x \vee 0]} g$. The function $g - \underline{g}$ is non-negative and continuous. Let $((a_i, b_i), i \in I)$ be the excursion intervals of $g - \underline{g}$ above 0. Because of the hypothesis on g , the intervals (a_i, b_i) are bounded. For $i \in I$, set $h_i = g(a_i)$ and $g_i(x) = g((a_i + x) \wedge b_i) - h_i$ so that $g_i \in \mathcal{E}$. Consider the forest $\mathbf{f} = ((h_i, T_{g_i}), i \in I)$.

It is elementary to check that $(\mathbf{f}_{(-\infty, g(0)]}, d_{\mathbf{f}}, g(0))$ and $(T_g, d_g, p_g(0))$ are root-preserving isometric. To conclude, it is enough to check that assumption of Corollary 2.6 is in force. Let $r > 0$ and set $r_g = \inf\{x, \underline{g}(x) \geq g(0) - r\}$ and $r_d = \sup\{x, \underline{g}(x) \geq g(0) - r\}$. Because of the hypothesis on g , we have that r_g and r_d are finite. By continuity of $g - \underline{g}$ on $[r_g, r_d]$, we deduce that for any $\varepsilon > 0$, the set $\{i \in I; (a_i, b_i) \subset [r_g, r_d] \text{ and } \sup_{(a_i, b_i)}(g - \underline{g}) > \varepsilon\}$ is finite. Since this holds for any $r > 0$ and that $H(T_{g_i}) = \sup_{(a_i, b_i)}(g - \underline{g})$ for all $i \in I$, we deduce that assumption of Corollary 2.6 is in force. This concludes the proof. \square

2.4.4. Genealogical tree of an extant population. For a tree $\mathbf{t} \in \mathcal{T}$ or $\mathbf{t} \in \mathcal{T}_1$ and $h \geq 0$, we define $\mathcal{Z}_h(\mathbf{t}) = \{x \in \mathbf{t}, h_{\mathbf{t}}(x) = h\}$ the set of vertices of \mathbf{t} at level h also called the extant population at time h , and the genealogical tree of the vertices of \mathbf{t} at level h by:

$$(6) \quad \mathcal{G}_h(\mathbf{t}) = \{x \in \mathbf{t}; \exists y \in \mathcal{Z}_h(\mathbf{t}) \text{ such that } x \preceq y\}.$$

For $\mathbf{t} \in \mathcal{T}$ and $h \in [0, H(\mathbf{t})]$, $\mathcal{G}_h(\mathbf{t})$ is indeed a tree and $\mathcal{G}_h(\mathbf{t}) = \emptyset$ for $h > H(\mathbf{t})$. For $(\mathbf{t}, d_{\mathbf{t}}, \rho_0, h_0) \in \mathcal{T}_1$, $\mathcal{G}_h(\mathbf{t})$ is a tree at least if $h \leq h_0$.

For a forest \mathbf{f} , we write $\mathcal{Z}_h(\mathbf{f})$ and $\mathcal{G}_h(\mathbf{f})$ for $\mathcal{Z}_h(\mathbf{f}_{(-\infty, h_0]})$ and $\mathcal{G}_h(\mathbf{f}_{(-\infty, h_0]})$ for any $h_0 \geq h$. Notice that for h given, the definitions of $\mathcal{Z}_h(\mathbf{f})$ and $\mathcal{G}_h(\mathbf{f})$ do not depend on $h_0 \geq h$. We shall also consider $\mathcal{Z}_h^*(\mathbf{f}) = \mathcal{Z}_h(\mathbf{f}) \cap \mathcal{S}(\mathbf{f}_{(-\infty, h]})^c$ the extant population at time h but the one in the semi-infinite branch $(-\infty, h]$. For $r \leq h$, we define the set of ancestors at time r in the past of the extant population at time h forgetting the individual in the infinite spine:

$$(7) \quad \mathcal{M}_r^h(\mathbf{f}) = \mathcal{G}_h(\mathbf{f}) \cap \mathcal{Z}_r^*(\mathbf{f})$$

and its cardinal

$$(8) \quad M_r^h(\mathbf{f}) = \text{Card}(\mathcal{M}_r^h(\mathbf{f})).$$

If \mathbf{f} satisfies condition of Corollary 2.6, then $M_r^h(\mathbf{f})$ is finite for all $r < h$.

3. THE REVERSED TREE

3.1. Backbones. We give an increasing family of backbones of $\mathbf{t} \in \mathcal{T}$. We denote by $S_0(\mathbf{t}) = \{x \in \mathbf{t}, h_{\mathbf{t}}(x) = H(\mathbf{t})\}$ the set of leaves with maximal height and we define the initial backbone

as the set of ancestors of $S_0(\mathbf{t})$:

$$B_0(\mathbf{t}) = \bigcup_{x \in S_0(\mathbf{t})} \llbracket \partial, x \rrbracket.$$

Notice that if the tree \mathbf{t} is height-regular, then $S_0(\mathbf{t}) = \{\partial^*\}$ and $B_0(\mathbf{t}) = \llbracket \partial, \partial^* \rrbracket$ is just the spine from the root of the tree to its tip. By convention, we set $B_0(\emptyset) = \{\partial\}$.

Let $(\tilde{\mathbf{t}}^i, i \in I_0)$ be the connected components of $\mathbf{t} \setminus B_0(\mathbf{t})$. If \mathbf{t}^i denotes the closure of $\tilde{\mathbf{t}}^i$, we have $\mathbf{t}^i = \tilde{\mathbf{t}}^i \cup \{x_i\}$ for a unique $x_i \in B_0(\mathbf{t})$ which can be viewed as the root of \mathbf{t}^i . Then, we define the family of backbones recursively: for $n \geq 1$, we set

$$B_n(\mathbf{t}) = B_0(\mathbf{t}) \otimes_{i \in I_0} (B_{n-1}(\mathbf{t}^i), x_i).$$

Remark 3.1. We can also use the alternative recursive definition

$$B_n(\mathbf{t}) = B_{n-1}(\mathbf{t}) \otimes_{i \in I_{n-1}} (B_0(\hat{\mathbf{t}}^i \cup \{y_i\}), y_i),$$

where the family $(\hat{\mathbf{t}}^i, i \in I_{n-1})$ is the connected components of $\mathbf{t} \setminus B_{n-1}(\mathbf{t})$ and y_i is the unique vertex of \mathbf{t} such that $\hat{\mathbf{t}}^i \cup \{y_i\}$ is closed (and y_i is then considered as the root of this tree).

Remark 3.2. It is easy to check that, if $\mathbf{t} \sim \mathbf{t}'$ then, for every $n \in \mathbb{N}$, $B_n(\mathbf{t}) \sim B_n(\mathbf{t}')$. So the function B_n is well defined on \mathbb{T} .

Lemma 3.3. *For every tree $\mathbf{t} \in \mathbb{T} \setminus \{\{\partial\}\}$ and every $\varepsilon \in (0, H(\mathbf{t})) > 0$, the erased tree $r_\varepsilon(\mathbf{t})$ has finitely many leaves and hence there exists an integer N (that depends on \mathbf{t} and ε) such that*

$$(9) \quad r_\varepsilon(\mathbf{t}) = \bigcup_{n=0}^N B_n(r_\varepsilon(\mathbf{t})).$$

Let us stress that, although the lemma is stated for $\mathbf{t} \in \mathbb{T}$, we will prove that it holds for $\mathbf{t} \in \mathcal{T}$, which is a stronger result. This argument will be used several times in the rest of the paper without being recalled.

Proof. Let $\mathbf{t} \in \mathcal{T} \setminus \{\{\partial\}\}$ and let $\varepsilon > 0$. We set N the number of leaves of $r_\varepsilon(\mathbf{t})$. If $N = +\infty$, there exists a (pairwise distinct) sequence $(y_n, n \in \mathbb{N})$ of leaves of $r_\varepsilon(\mathbf{t})$. Then, by definition the subtrees \mathbf{t}_{y_n} of \mathbf{t} are pairwise disjoint and have height ε . Hence, if we choose for every $n \in \mathbb{N}$ a point x_n in \mathbf{t}_{y_n} such that $h_{\mathbf{t}_n}(x_n) = \varepsilon$, the sequence $(x_n, n \in \mathbb{N})$ satisfies

$$\forall i, j \in \mathbb{N}, i \neq j \implies d_{\mathbf{t}}(x_i, x_j) \geq 2\varepsilon$$

which contradicts the compactness of the tree \mathbf{t} . So N is finite and (9) trivially holds. \square

Lemma 3.4. *Let $\mathbf{t} \in \mathbb{T} \setminus \{\{\partial\}\}$.*

- *We have $\text{cl}(\bigcup_{n \in \mathbb{N}} B_n(\mathbf{t})) = \mathbf{t}$.*
- *Furthermore, if $\mathbf{t} \in \mathbb{T}_0$, then we have $\bigcup_{n \in \mathbb{N}} \mathcal{L}(B_n(\mathbf{t})) = \mathcal{L}^*(\mathbf{t})$.*

Proof. Let $\mathbf{t} \in \mathcal{T} \setminus \{\{\partial\}\}$. Let $x \in \text{sk}(\mathbf{t})$ and set $\varepsilon = H(\mathbf{t}_x) > 0$. By definition, $x \in r_\varepsilon(\mathbf{t})$ and, by Lemma 3.3, $x \in \bigcup_{n \in \mathbb{N}} B_n(\mathbf{t})$, which proves that $\text{sk}(\mathbf{t}) \subset \bigcup_{n \in \mathbb{N}} B_n(\mathbf{t})$. Then the first point follows from the fact that $\text{cl}(\text{sk}(\mathbf{t})) = \mathbf{t}$.

For the second point, let us suppose that $\mathbf{t} \in \mathcal{T}_0$ and let $x \in \mathcal{L}(B_n(\mathbf{t}))$ for some $n \in \mathbb{N}$. Then, by definition of $B_n(\mathbf{t})$, x is the tip of a subtree of the form \mathbf{t}_y , with $y \prec x$ and, as $\mathbf{t} \in \mathcal{T}_0$, it therefore belongs to $\mathcal{L}^*(\mathbf{t})$. Conversely, let $x \in \mathcal{L}^*(\mathbf{t})$. Then there exists $y \in \text{sk}(\mathbf{t})$ such that $y^* = x$. Let us set $\varepsilon = d(y, x) > 0$. Then $y \in r_\varepsilon(\mathbf{t})$ and, by Lemma 3.3, $y \in B_n(\mathbf{t})$ for some $n \in \mathbb{N}$. And by definition, $x = y^* \in \mathcal{L}(B_n(\mathbf{t}))$ for the same n . \square

3.2. Reversed tree. The reversal of a tree is only defined for a tree $\mathbf{t} \in \mathcal{T}_0$. As already noticed, since \mathbf{t} is height regular, we have $S_0(\mathbf{t}) = \{\partial^*\}$ and $B_0(\mathbf{t}) = \llbracket \partial, \partial^* \rrbracket$. Similarly, using the notations of Section 3.1, for every $i \in I_0$, as \mathbf{t}^i is also height-regular, we have $B_0(\mathbf{t}^i) = \llbracket x_i, x_i^* \rrbracket$. For every $i \in I_0$, we set y'_i the unique point of $B_0(\mathbf{t})$ which is at the same height as x_i^* :

$$y'_i \in \llbracket \partial, \partial^* \rrbracket, \quad h_{\mathbf{t}}(y'_i) = h_{\mathbf{t}}(x_i^*).$$

We then define recursively the reversed backbones as follows. We set, for $n \geq 0$,

$$\mathcal{R}_0(\mathbf{t}) = (\llbracket \partial^*, \partial \rrbracket, d, \partial^*).$$

(notice that the root of $\mathcal{R}_0(\mathbf{t})$ is ∂^*) and for $n \geq 1$,

$$\mathcal{R}_n(\mathbf{t}) = \mathcal{R}_0(\mathbf{t}) \otimes_{i \in I_0} (\mathcal{R}_{n-1}(\mathbf{t}^i), y'_i).$$

The reversal procedure is illustrated on Figure 2, the dashed lines show where the trees are grafted on the reversed tree. Notice that, for aesthetic purpose, inside a sub-tree, the branches are drawn from left to right in decreasing order of their height.

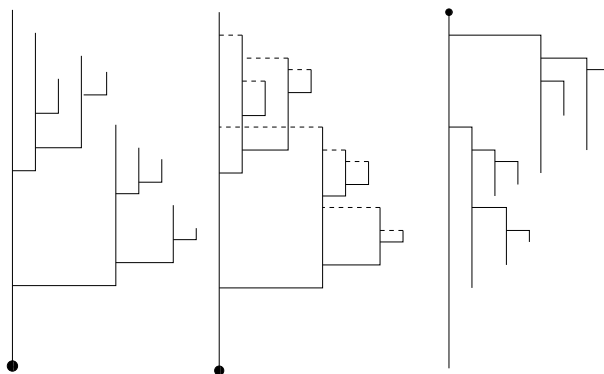

FIGURE 2. A backbone $B_3(\mathbf{t})$ on the left and its reversed tree $\mathcal{R}_3(\mathbf{t})$ on the right. The root of each tree is represented by a bullet.

Intuitively, the leaves of $\mathcal{R}_n(\mathbf{t})$ correspond to branching points of $B_n(\mathbf{t})$ (or to its root) and conversely. Therefore, it is easy to check that $\mathcal{R}_n(\mathbf{t}) \in \mathcal{T}_0$ for every $n \in \mathbb{N}$.

The sequence of trees $(\mathcal{R}_n(\mathbf{t}), n \geq 0)$ is non-decreasing. We endow $\bigcup_{n \geq 0} \mathcal{R}_n(\mathbf{t})$ with the natural distance denoted by $d^{\mathcal{R}}$ and we define the reversed tree $\mathcal{R}(\mathbf{t})$ as the completion of $\bigcup_{n \geq 0} \mathcal{R}_n(\mathbf{t})$ with respect to the distance $d^{\mathcal{R}}$.

Remark 3.5. As for B_n , it is easy to check that the reversal procedure \mathcal{R} is well defined on \mathbb{T}_0 .

Lemma 3.6. *Let $\theta \geq 0$. Let τ be a Brownian CRT under the excursion measure $\mathbb{N}^{(\theta)}$. Then, we have that $\mathbb{N}^{(\theta)}$ -a.e., $\tau \in \mathbb{T}_0$.*

Proof. Let $h > 0$. Following [20, 21], we say that a process X admits a h -minimum (resp. a h -maximum) at time t if there exist $s < t$ and $u > t$ such that $X_s = X_u = X_t + h$ (resp. $X_s = X_u = X_t - h$) and $X_r \geq X_t$ (resp. $X_r \leq X_t$) for every $r \in [s, u]$.

Then, if we denote by e an excursion under $n^{(\theta)}$ and τ the associated real tree, for a.e. h the branching points of $r_h(\tau)$ correspond to the h -minima of e and each leaf of $r_h(\tau)$ is associated with an h -maxima of e . As $n^{(\theta)}$ -a.e., two local extrema of the excursion e have different levels, we get that $\tau \in \mathbb{T}_0$, $\mathbb{N}^{(\theta)}$ -a.e. □

Let τ be a Brownian CRT under the excursion measure $\mathbb{N}^{(\theta)}$, with $\theta \geq 0$. We keep the notations of Section 3.1: we set $B_0(\tau) = \llbracket \partial, \partial^* \rrbracket$ and set $(\tau_i, i \in I_0)$ the closures of the connected components of $\tau \setminus B_0(\tau)$ viewed as trees in \mathcal{T} rooted respectively at point $x_i \in B_0(\tau)$ so that $\tau = B_0(\tau) \otimes_{i \in I_0} (\tau_i, x_i)$.

Lemma 3.7. *Let $\theta \geq 0$. Under $\mathbb{N}^{(\theta)}$, the point measure $\sum_{i \in I_0} \delta_{(h-u_i-H(\tau_i), \tau_i)}$ on $[0, h] \times \mathbb{T}$ is, conditionally given $\{H(\tau) = h\}$, a Poisson point measure with intensity*

$$(10) \quad 2\beta \mathbf{1}_{(0, h)}(u) du \mathbb{N}^{(\theta)}[dt, H(\mathbf{t}) \leq h - u].$$

Proof. By the Williams decomposition (see [1]), the point measure $\sum_{i \in I_0} \delta_{(u_i, \tau_i)}$ is under $\mathbb{N}^{(\theta)}$, conditionally given $\{H(\tau) = h\}$, a Poisson point measure with intensity (10). Then, for every non-negative function φ on $[0, h] \times \mathbb{T}$, we have

$$\begin{aligned} \mathbb{N}^{(\theta)} \left[e^{-\sum_{i \in I_0} \varphi(h-u_i-H(\tau_i), \tau_i)} \mid H(\tau) = h \right] &= \exp \left(- \int_0^h 2\beta du \mathbb{N}^{(\theta)} \left[\left(1 - e^{-\varphi(h-u-H(\tau), \tau)} \right) \mathbf{1}_{\{H(\tau) \leq h-u\}} \right] \right) \\ &= \exp \left(-2\beta \mathbb{N}^{(\theta)} \left[\int_0^{h-H(\tau)} du \left(1 - e^{-\varphi(h-u-H(\tau), \tau)} \right) \mathbf{1}_{\{H(\tau) \leq h\}} \right] \right) \\ &= \exp \left(-2\beta \mathbb{N}^{(\theta)} \left[\int_0^{h-H(\tau)} dv \left(1 - e^{-\varphi(v, \tau)} \right) \mathbf{1}_{\{H(\tau) \leq h\}} \right] \right) \\ &= \exp \left(- \int_0^h 2\beta dv \mathbb{N}^{(\theta)} \left[\left(1 - e^{-\varphi(v, \tau)} \right) \mathbf{1}_{\{H(\tau) \leq h-v\}} \right] \right), \end{aligned}$$

where we performed the change of variables $v = h - u - H(\tau)$ for the third equality. The lemma follows. \square

Theorem 3.8. *Let $\theta \geq 0$. Let τ be a Brownian CRT under the excursion measure $\mathbb{N}^{(\theta)}$. Then, $\mathcal{R}(\tau)$ is distributed as τ .*

Proof. To prove the theorem, it suffices to prove, using Lemma 3.4, that for every $n \in \mathbb{N}$, $B_n(\tau)$ and $\mathcal{R}_n(\tau)$ are equally distributed, which we prove by induction.

First, as $\tau \in \mathbb{T}_0$ $\mathbb{N}^{(\theta)}$ -a.e., we have $B_0(\tau) = \mathcal{R}_0(\tau)$ (viewed as equivalence classes). They have consequently the same distribution.

Suppose now that $B_{n-1}(\tau)$ and $\mathcal{R}_{n-1}(\tau)$ are equally distributed for some $n \geq 1$. Recall that

$$B_n(\tau) = B_0(\tau) \otimes_{i \in I_0} (B_{n-1}(\tau_i), x_i) \quad \text{and} \quad \mathcal{R}_n(\tau) = \mathcal{R}_0(\tau) \otimes_{i \in I_0} (\mathcal{R}_{n-1}(\tau_i), y'_i)$$

where for every $i \in I_0$, y'_i is the unique point of $B_0(\tau)$ which has the same height as x_i^* i.e. such that $h_\tau(y'_i) = h_\tau(x_i) + H(\tau_i)$. Notice that, as a vertex of $\mathcal{R}_0(\tau)$, h'_i has height $h_{\mathcal{R}_0(\tau)}(y'_i) = H(\tau) - h_\tau(x_i) - H(\tau_i)$.

Thanks to Lemma 3.7, conditionally given $B_0(\tau)$, the two families $((h_\tau(x_i), \tau_i), i \in I_0)$ and $((h_{\mathcal{R}_0(\tau)}(y'_i), \tau_i), i \in I_0)$ have the same distribution. By the induction assumption, the families $((h_\tau(x_i), B_{n-1}(\tau_i)), i \in I_0)$ and $((h_{\mathcal{R}_0(\tau)}(y'_i), \mathcal{R}_{n-1}(\tau_i)), i \in I_0)$ have also the same distribution. This implies that, under $\mathbb{N}^{(\theta)}$, $B_n(\tau)$ and $\mathcal{R}_n(\tau)$ are equally distributed. \square

The reverse operation is natural on the Brownian CRT but it has no elementary representation for the underlying Brownian excursion.

Recall the definition in Section 2.3 of the local time measure $\ell_a(dx)$ of a Brownian CRT τ at level a . We denote by $\ell_a(\tau)$ the total mass of this measure.

Proposition 3.9. *Let $\theta \geq 0$. $\mathbb{N}^{(\theta)}$ -a.e., for every $a \geq 0$, $\ell_a(\tau) = \ell_{H(\tau)-a}(\mathcal{R}(\tau))$.*

Proof. Let $a \geq 0$. Using Theorem 4.2 of [13], we have $\mathbb{N}^{(\theta)}$ -a.e. that:

$$\ell_a(\tau) = \lim_{\varepsilon \rightarrow 0} \frac{1}{\varepsilon} \text{Card} \{x \in r_\varepsilon(\tau), h_\tau(x) = a - \varepsilon\} = \lim_{\varepsilon \rightarrow 0} \frac{1}{\varepsilon} \text{Card} \{x \in r_\varepsilon(\tau), h_\tau(x) = a\}.$$

But, by construction, we have, for every $\mathbf{t} \in \mathbb{T}$ and every $\varepsilon > 0$,

$$\text{Card} (\{x \in r_\varepsilon(\mathbf{t}), h_{\mathbf{t}}(x) = a - \varepsilon\}) = \text{Card} (\{x \in r_\varepsilon(\mathcal{R}(\mathbf{t})), h_{\mathcal{R}(\mathbf{t})}(x) = H(\mathbf{t}) - a\}).$$

Therefore, we have that for every $a \geq 0$, $\mathbb{N}^{(\theta)}$ -a.e., $\ell_a(\tau) = \ell_{H(\tau)-a}(\mathcal{R}(\tau))$. Then, consider the continuous version of the local time to conclude. \square

3.3. Extension to a forest. For $\theta \geq 0$, we define the Brownian forest as the forest $\mathcal{F} = ((h_i, \tau_i), i \in I)$ where $\sum_{i \in I} \delta_{h_i, \tau_i}$ is a Poisson point measure on $\mathbb{R} \times \mathbb{T}$ with intensity $2\beta dh \mathbb{N}^{(\theta)}[d\tau]$ and we denote by $\mathbb{P}^{(\theta)}$ its distribution. Notice that the forest \mathcal{F} satisfies condition of Corollary 2.6, so that the tree $\mathcal{F}_{(-\infty, t]}$ is complete and locally compact and thus belongs to \mathbb{T}_1 .

Remark 3.10. This Brownian forest can be viewed as the genealogical tree of a stationary continuous-state branching process (associated with the branching mechanism ψ_θ defined in (4)), see [8]. To be more precise, for every $i \in I$ let $(\ell_a^{(i)})_{a \geq 0}$ be the local time measures of the tree τ_i . For every $t \in \mathbb{R}$, we define the size Z_t of the population at time t by

$$(11) \quad Z_t = \sum_{i \in I} \ell_{t-h_i}^{(i)}(\tau_i),$$

where we recall that the local time $\ell_a(\tau)$ of the CRT τ is zero for $a \notin [0, H(\tau)]$. For $\theta = 0$, we have $Z_t = +\infty$ a.s. for every $t \in \mathbb{R}$. For $\theta > 0$, the process $(Z_t, t \geq 0)$ is a stationary Feller diffusion, solution of the SDE

$$dZ_t = \sqrt{2\beta Z_t} dB_t + 2\beta(1 - \theta Z_t) dt.$$

A forest $\mathbf{f} = ((h_i, \mathbf{t}_i), i \in I)$ is said to be height-regular if:

- for every $i \in I$, $\mathbf{t}_i \in \mathbb{T}_0$;
- for every $i, j \in I$, if $i \neq j$, then $h_i \neq h_j$ and $h_i + H(\mathbf{t}_i) \neq h_j + H(\mathbf{t}_j)$.

We define the reverse of a height-regular forest $\mathbf{f} = ((h_i, \mathbf{t}_i), i \in I)$ as the forest

$$\mathcal{R}(\mathbf{f}) = ((-h_i - H(\mathbf{t}_i), \mathcal{R}(\mathbf{t}_i)), i \in I).$$

Lemma 3.11. *Let $\theta \geq 0$. Let $((h_i, \tau_i), i \in I)$ be a Brownian forest under $\mathbb{P}^{(\theta)}$. Then the point process*

$$\sum_{i \in I} \delta_{(-h_i - H(\tau_i), \tau_i)}(dh, d\mathbf{t})$$

is a Poisson point process on $\mathbb{R} \times \mathbb{T}$ with intensity $2\beta dh \mathbb{N}^{(\theta)}[d\mathbf{t}]$.

Proof. The proof is similar to the one of Lemma 3.7. For every non-negative measurable function φ on $\mathbb{R} \times \mathbb{T}$, we have

$$\begin{aligned} \mathbb{E}_\theta \left[e^{-\sum_{i \in I} \varphi(-h_i - H(\tau_i), \tau_i)} \right] &= \exp \left(- \int_{-\infty}^{+\infty} 2\beta dh \mathbb{N}^{(\theta)} \left[1 - e^{-\varphi(-h - H(\tau), \tau)} \right] \right) \\ &= \exp \left(-2\beta \mathbb{N}^{(\theta)} \left[\int_{-\infty}^{+\infty} \left(1 - e^{-\varphi(-h - H(\tau), \tau)} \right) dh \right] \right) \\ &= \exp \left(-2\beta \mathbb{N}^{(\theta)} \left[\int_{-\infty}^{+\infty} \left(1 - e^{-\varphi(v, \tau)} \right) dv \right] \right) \end{aligned}$$

by an obvious change of variables, which yields the result. \square

We deduce from Lemma 3.11, Lemma 3.6 and Theorem 3.8 the following corollary.

Corollary 3.12. *Let $\theta \geq 0$. Let \mathcal{F} be a Brownian forest under $\mathbb{P}^{(\theta)}$. Then \mathcal{F} is a.s. height regular and the reversed forest $\mathcal{R}(\mathcal{F})$ is distributed as \mathcal{F} .*

This corollary allows to straightforwardly recover (and understand) Lemma 4.1 and Theorem 4.3 from [5].

3.4. Renormalized total length of the genealogical tree. Let $\mathcal{F} = ((h_i, \tau_i), i \in I)$ be a Brownian forest under $\mathbb{P}^{(\theta)}$. Recall that the tree $\mathcal{F}_{(-\infty, t]}$ belongs to \mathcal{T}_1 . Its population at time t , $\mathcal{Z}_t(\mathcal{F})$, is defined in Section 2.4.4 and its size Z_t is defined by (11). Recall Definitions (7) and (8) of $\mathcal{M}_s^t(\mathcal{F})$ the set of ancestors at time s of $\mathcal{Z}_t(\mathcal{F})$, the extant population at time t , and $M_s^t = M_s^t(\mathcal{F})$ its cardinal. Recall that we forget about the infinite spine in $\mathcal{M}_s^t(\mathcal{F})$. Notice that M_s^t is finite for all $s < t$. We also define the time to the MRCA of $\mathcal{Z}_t(\mathcal{F})$ as

$$(12) \quad A_t = t - \sup \{r \leq t; M_r^t = 0\}.$$

We want to define the length of the genealogical tree $\mathcal{G}_t(\mathcal{F})$ of all extant individuals at time t (which is a.s. infinite) by approximating this genealogical tree by finite ones. To study the length $\mathcal{G}_t(\mathcal{F})$, two strategies are possible. The first one is to consider for $\varepsilon > 0$ the genealogical tree of individuals at time $t - \varepsilon$, with descendants at time 0, and let ε goes down to 0.

Without loss of generality we can take $t = 0$ (since the distribution of the Brownian forest is invariant by time translation). We define the total length of the genealogical tree of the current population up to $\varepsilon > 0$ in the past as:

$$(13) \quad L_\varepsilon = \int_\varepsilon^\infty M_{-s}^0 ds.$$

Set $L = (L_\varepsilon, \varepsilon > 0)$. According to [5], we have $\mathbb{E}[L_\varepsilon | Z_0] = -Z_0 \log(2\beta\theta\varepsilon)/\beta + O(\varepsilon)$, see (23), and that the sequence $(L_\varepsilon - \mathbb{E}[L_\varepsilon | Z_0], \varepsilon > 0)$ converges a.s. as ε goes down to zero towards a limit say \mathcal{L} . Furthermore, for all $\lambda > 0$,

$$\mathbb{E} \left[e^{-\lambda \mathcal{L}} | Z_0 \right] = e^{\theta Z_0 \varphi(\lambda/(2\beta\theta))}, \quad \text{with} \quad \varphi(\lambda) = \lambda \int_0^1 \frac{1-v^\lambda}{1-v} dv.$$

The second strategy consists in looking at the genealogical tree associated with n individuals picked at random in the population at time 0. For this reason, we consider the measure \mathbf{Z}_h on $\mathcal{Z}_h(\mathcal{F})$ defined by:

$$(14) \quad \mathbf{Z}_h(dx) = \sum_{i \in I} \mathbf{1}_{\tau_i}(x) \ell_{h-h_i}^{(i)}(dx),$$

and write $Z_h = \mathbf{Z}_h(1)$ for its total mass. Remark that this definition coincides with Definition (11) of the total population process. In particular $\mathbf{Z}_h(1)$ is a.s. finite as $\theta > 0$. Let $(X_k, k \in \mathbb{N}^*)$ be, conditionally on \mathcal{F} , independent random variables with distribution $\mathbf{Z}_0(dx)/Z_0$. This models individuals uniformly chosen among the population living at time 0. Define the ancestors of X_1, \dots, X_n at time $s < 0$ as:

$$\mathcal{M}_s^{(n)}(\mathcal{F}) = \{x \in \mathcal{M}_s^0(\mathcal{F}); x \prec X_i \text{ for some } 1 \leq i \leq n\},$$

and $M_s^{(n)} = \text{Card}(\mathcal{M}_s^{(n)}(\mathcal{F}))$ its cardinal. We define the total length of the genealogical tree of n individuals uniformly chosen in the current population as:

$$(15) \quad \Lambda_n = \int_0^\infty M_{-s}^{(n)} ds.$$

Set $\Lambda = (\Lambda_n, n \in \mathbb{N}^*)$. The next proposition, whose proof is postponed to the end of the paper (and requires the notations of the next sections), says that the two strategies give the same limit a.s.

Proposition 3.13. *The sequence $(\Lambda_n - \mathbb{E}[\Lambda_n|Z_0], n \in \mathbb{N}^*)$ converges a.s. and in L^2 towards \mathcal{L} as n goes down to 0. And we also have $\mathbb{E}[\Lambda_n|Z_0] = \frac{Z_0}{\beta} \log\left(\frac{n}{2\theta Z_0}\right) + O(n^{-1} \log(n))$.*

4. ANCESTRAL PROCESS

Usually, the ancestral process records the genealogy of n extant individuals at time 0 picked at random among the whole population. Using the ideas of [4], we are able to describe in the case of a Brownian forest the genealogy of all extant individuals at time 0 by a simple Poisson point process on \mathbb{R}^2 .

4.1. Construction of a tree from a point measure.

Definition 4.1. *A point process $\mathcal{A}(dx, d\zeta) = \sum_{i \in \mathcal{I}} \delta_{(x_i, \zeta_i)}(dx, d\zeta)$ on $\mathbb{R}^* \times (0, +\infty)$ is said to be an ancestral process if*

- (i) $\forall i, j \in \mathcal{I}, i \neq j \implies x_i \neq x_j$.
- (ii) $\forall a, b \in \mathbb{R}, \forall \varepsilon > 0, A([a, b] \times [\varepsilon, +\infty)) < +\infty$.
- (iii) $\sup\{\zeta_i, x_i > 0\} = +\infty$ if $\sup_{i \in \mathcal{I}} x_i = +\infty$; and $\sup\{\zeta_i, x_i < 0\} = +\infty$ if $\inf_{i \in \mathcal{I}} x_i = -\infty$.

Let $\mathcal{A} = \sum_{i \in \mathcal{I}} \delta_{(x_i, \zeta_i)}$ be a point process on $\mathbb{R}^* \times [0, +\infty)$ satisfying (i) and (ii) from Definition 4.1. We shall associate with this ancestral process a genealogical tree. Informally the genealogical tree is constructed as follows. We view this process as a sequence of vertical segments in \mathbb{R}^2 , the tips of the segments being the x_i 's and their lengths being the ζ_i 's. We then attach the bottom of each segment such that $x_i > 0$ (resp. $x_i < 0$) to the first left (resp. first right) longer segment or to the half line $\{0\} \times (-\infty, 0]$ if such a segment does not exist. This gives a (unrooted, non-compact) real tree that may not be complete. See also Figure 3 for an example.

Let us turn to a more formal definition. Let us denote by $\mathcal{I}^d = \{i \in \mathcal{I}, x_i > 0\}$ and $\mathcal{I}^g = \{i \in \mathcal{I}, x_i < 0\} = \mathcal{I} \setminus \mathcal{I}^d$. We also set $\mathcal{I}_0 = \mathcal{I} \sqcup \{0\}$, $x_0 = 0$ and $\zeta_0 = +\infty$. We set, for every $i \in \mathcal{I}_0$, $S_i = \{x_i\} \times (-\zeta_i, 0]$ the vertical segment in \mathbb{R}^2 that links the points $(x_i, 0)$ and $(x_i, -\zeta_i)$. Notice that we omit the lowest point of the vertical segments. Finally we define

$$(16) \quad \mathfrak{T} = \bigsqcup_{i \in \mathcal{I}_0} S_i.$$

We now define a distance on \mathfrak{T} . We first define the distance between leaves of \mathfrak{T} , i.e. points $(x_i, 0)$ with $i \in \mathcal{I}_0$, then we extend it to every point of \mathfrak{T} . For $i, j \in \mathcal{I}_0$ such that $x_i < x_j$, we set

$$(17) \quad d((x_i, 0), (x_j, 0)) = 2 \max\{\zeta_k, x_k \in J(x_i, x_j)\},$$

where, for $x < y$, $J(x, y) = (x, y]$ (resp. $[x, y)$, resp. $[x, y]$) if $x \geq 0$ (resp. $y \leq 0$, resp. $x < 0$ and $y > 0$), with the convention $\max \emptyset = 0$. For $u = (x_i, a) \in S_i$ and $v = (x_j, b) \in S_j$, we set, with $r = \frac{1}{2}d((x_i, 0), (x_j, 0))$:

$$(18) \quad d(u, v) = |a - b| \mathbf{1}_{\{x_i = x_j\}} + (|a - r| + |b - r|) \mathbf{1}_{\{x_i \neq x_j\}}.$$

It is easy to verify that d is a distance on \mathfrak{T} . Notice that \mathfrak{T} is not compact in particular because of the infinite half-line attached to $(0, 0)$. In order to stick to the framework of Section 2.4, the origin $(0, 0)$ will be the distinguished point in \mathfrak{T} located at height $h = 0$.

Finally, we define $\mathfrak{T}(\mathcal{A}) = \overline{\mathfrak{T}}$, with the metric d , as the completion of the metric space (\mathfrak{T}, d) .

Remark 4.2. For every $i \in \mathcal{I}^d$, we set i_g the index in \mathcal{I}_0 such that

$$x_{i_g} = \max\{x_j, 0 \leq x_j < x_i \text{ and } \zeta_j > \zeta_i\}.$$

Remark that i_g is well defined since there are only a finite number of indices $j \in \mathcal{I}_0$ such that $x_j \in [0, x_i)$ and $\zeta_j > \zeta_i$. Similarly, for $i \in \mathcal{I}^g$, we set i_d the index in \mathcal{I}_0 such that

$$x_{i_d} = \min\{x_j, x_i < x_j \leq 0 \text{ and } \zeta_j > \zeta_i\}.$$

The distance d identifies the point (x_i, ζ_i) (which does not belong to \mathfrak{T} by definition) with the point (x_{i_g}, ζ_i) if $x_i > 0$ and with the point (x_{i_d}, ζ_i) if $x_i < 0$ as illustrated on the right-hand side of Figure 3.

Proposition 4.3. *Let \mathcal{A} be an ancestral process. The quadruplet $(\mathfrak{T}(\mathcal{A}), d, (0, 0), 0)$ belongs to \mathcal{T}_1 .*

We shall call $\mathfrak{T}(\mathcal{A})$ the tree associated with the ancestral process \mathcal{A} .

Proof. As the completion of a real tree is still a real tree, it is enough to prove that (\mathfrak{T}, d) is a real tree, with \mathfrak{T} defined by (16) and d defined by (17) and (18).

First case: \mathcal{I} finite.

We can suppose that $\mathcal{I} = \{1, \dots, n\}$ with $x_1 < x_2 < \dots < x_n$ (with $x_i \neq 0$ for $i \in \mathcal{I}$). We consider the continuous, piece-wise affine function g on \mathbb{R} such that

- For $1 \leq i \leq n$, $g(x_i) = -\zeta_i$,
- For $1 \leq i \leq n-1$, $g\left(\frac{x_i+x_{i+1}}{2}\right) = 0$,
- $g(x_1-1) = g(x_n+1) = 0$,
- $g'(x) = -1$ for $x < x_1-1$ and $g'(x) = 1$ for $x > x_n+1$.

Then, it is easy to see that (\mathfrak{T}, d) is the tree T_g coded by g (see Section 2.4) and hence is a real tree. Notice that the number of leaves of \mathfrak{T} is $\text{Card}(\mathcal{I}_0) = n+1$.

Second case: \mathcal{I} infinite, $\sup_{i \in \mathcal{I}} x_i < +\infty$ and $\inf_{i \in \mathcal{I}} x_i > -\infty$.

In that case, by Condition (ii) in Definition 4.1, we can order the set \mathcal{I} via a sequence (i_1, i_2, \dots) such that the sequence $(\zeta_{i_k}, k \geq 1)$ is non-increasing. For every $n \geq 1$, we denote by (\mathfrak{T}_n, d_n) the tree associated with the ancestral process $\sum_{k=1}^n \delta_{(x_{i_k}, \zeta_{i_k})}$ (which is indeed a tree according to the first case). Remark first that $\mathfrak{T}_n \subset \mathfrak{T}_{n+1}$. Moreover, as $\zeta_{i_{n+1}} \leq \zeta_{i_k}$ for every $1 \leq k \leq n$, we deduce from (17) that d_n is equal to the restriction of d_{n+1} to \mathfrak{T}_n . Therefore, we have $\mathfrak{T} = \bigcup_{n \geq 1} \mathfrak{T}_n$ and d is the distance induced by the distances d_n . We deduce that (\mathfrak{T}, d) is a real tree as limit of increasing real trees. Indeed, clearly \mathfrak{T} is connected (as the union of an increasing sequence of connected sets) and d satisfies the so-called "4-points condition" (see Lemma 3.12 in [14]). To conclude, use that those two conditions characterize real trees (see Theorem 3.40 in [14]). We deduce that (\mathfrak{T}, d) is a real tree.

Third case: \mathcal{I} infinite and $\sup_{i \in \mathcal{I}} x_i = +\infty$ or $\inf_{i \in \mathcal{I}} x_i = -\infty$.

We consider in that case, for every integer $n \geq 1$ the tree (\mathfrak{T}_n, d_n) induced by the ancestral process \mathcal{A} restricted to $[-n, n] \times [0, +\infty)$ (which is indeed a tree by the second case). We still have $\mathfrak{T} = \bigcup_{n \geq 1} \mathfrak{T}_n$ and the compatibility condition for the distances. We then conclude as for the second case that (\mathfrak{T}, d) is a real tree.

By construction of \mathfrak{T} , it is easy to check that $\mathfrak{T}(\mathcal{A})$ has a unique semi-infinite branch.

Let us now prove that $\mathfrak{T}(\mathcal{A})$ is locally compact. Let $(y_n, n \in \mathbb{N})$ be a bounded sequence of \mathfrak{T} .

On one hand, let us assume that there exists $i \in \mathcal{I}_0$ and a sub-sequence $(y_{n_k}, k \in \mathbb{N})$ such that y_{n_k} belongs to $S_i = \{x_i\} \times \{(-\zeta_i, 0]\}$. Since, for $i \in \mathcal{I}$, $S_i \cup \{0\} \times \{-\zeta_i\}$ is compact and for $i = 0$, $S_0 = \{0\} \times (-\infty, 0]$, we deduce that the bounded sequence $(y_{n_k}, k \in \mathbb{N})$ has an accumulation point in $S_i \cup \{0\} \times \{-\zeta_i\}$ if $i \in \mathcal{I}$ or in $\{0\} \times (-\infty, 0]$ if $i = 0$.

On the other hand, let us assume that for all $i \in \mathcal{I}_0$ the sets $\{n, y_n \in S_i\}$ are finite. For $n \in \mathbb{N}$, let i_n uniquely defined by $y_n \in S_{i_n}$. Since $(y_n, n \in \mathbb{N})$ is bounded, we deduce from Condition (iii) in Definition 4.1, that the sequence $(x_{i_n}, n \in \mathbb{N})$ is bounded in \mathbb{R} . In particular, there is a sub-sequence such that $(x_{i_{n_k}}, k \in \mathbb{N})$ converges to a limit say a . Without loss of generality, we can assume that the sub-sequence is non-decreasing. We deduce from Condition (ii) in Definition (4.1) that $\lim_{\varepsilon \downarrow 0} \max\{\zeta_i, a - \varepsilon < x_i < a\} = 0$. This implies thanks to Definition (17) that $(\{x_{i_{n_k}}\} \times \{0\}, k \in \mathbb{N})$ is Cauchy in \mathfrak{T} and using (ii) again that $\lim_{k \rightarrow +\infty} \zeta_{i_{n_k}} = 0$. Then use that

$$d(y_{n_k}, y_{n_{k'}}) \leq \zeta_{i_{n_k}} + \zeta_{i_{n_{k'}}} + d((x_{n_k}, 0), (x_{n_{k'}}, 0))$$

to conclude that the $(y_{n_k}, k \in \mathbb{N})$ is Cauchy in \mathfrak{T} .

We deduce that all bounded sequence in \mathfrak{T} has a Cauchy sub-sequence. This proves that $\mathfrak{T}(\mathcal{A})$, the completion of \mathfrak{T} is locally compact. \square

Remark 4.4. In the proof of Proposition 4.3, Conditions (i) and (ii) in Definition 4.1 insure that $\mathfrak{T}(\mathcal{A})$ is a tree and Condition (iii) that $\mathfrak{T}(\mathcal{A})$ is locally compact.

4.2. The ancestral process of the Brownian forest. Let $\theta \geq 0$. Let $\mathcal{N}(dh, d\varepsilon, de) = \sum_{i \in I} \delta_{(h_i, \varepsilon_i, e_i)}(dh, d\varepsilon, de)$ be, under $\mathbb{P}^{(\theta)}$, a Poisson point measure on $\mathbb{R} \times \{-1, 1\} \times \mathcal{E}$ with intensity $\beta dh (\delta_{-1}(d\varepsilon) + \delta_1(d\varepsilon)) n^{(\theta)}(de)$, and let $\mathcal{F} = ((h_i, \tau_i), i \in I)$ be the associated Brownian forest where $\tau_i = T_{e_i}$ is the tree associated with the excursion e_i , see Section 2.3. As explained in Section 3.3, this Brownian forest models the evolution of a stationary population directed by the branching mechanism ψ_θ defined in (4).

We want to describe the genealogical tree of the extant population at some fixed time, say 0. The looked after genealogical tree is then $\mathcal{G}_0(\mathcal{F})$ defined by (6). To describe the distribution of this tree, we use an ancestral process as described in the previous subsection. We first construct a contour process $(B_t, t \in \mathbb{R})$ (obtained by the concatenation of two Brownian motions with drift) which codes for the tree $\mathcal{F}_{(-\infty, 0]}$ (see Section 2.4 for the notations). The supplementary variables ε_i are needed at this point to decide if the tree \mathbf{t}_i is located on the left or on the right of the infinite spine. The atoms of the ancestral process are then the pairs formed by the points of growth of the local time at 0 of B and the depth of the associated excursion of B below 0.

4.2.1. Construction of the contour process. Set $\tilde{\mathcal{I}} = \{i \in I; h_i < 0, h_i + \max(e_i) > 0\}$. For every $i \in \tilde{\mathcal{I}}$, we set:

$$g_i = \sum_{j \in \tilde{\mathcal{I}}} \mathbf{1}_{\{\varepsilon_j = \varepsilon_i\}} \mathbf{1}_{\{h_j > h_i\}} \sigma(e_j) \quad \text{and} \quad d_i = g_i + \sigma(e_i),$$

where we recall that $\sigma(e_i)$ is the length of excursion e_i . For every $t \geq 0$, we set i_t^d (resp. i_t^g) the only index $i \in \tilde{\mathcal{I}}$ such that $\varepsilon_i = 1$ (resp. $\varepsilon_i = -1$) and $g_i \leq t < d_i$. Notice that for all $t \geq 0$ a.s. i_t^d and i_t^g are well defined. We set $B^d = (B_t^d, t \geq 0)$ and $B^g = (B_t^g, t \geq 0)$ where for $t \geq 0$:

$$B_t^d = h_{i_t^d} + e_{i_t^d}(t - g_{i_t^d}) \quad \text{and} \quad B_t^g = h_{i_t^g} + e_{i_t^g}(\sigma(e_{i_t^g}) - (t - g_{i_t^g})).$$

By standard excursion theory, we have the following result.

Proposition 4.5. *Let $\theta \geq 0$. The processes B^d and B^g are two independent Brownian motions distributed as $B^{(\theta)}$.*

We define the process $B = (B_t, t \in \mathbb{R})$ by $B_t = B_t^d \mathbf{1}_{\{t>0\}} + B_{-t}^g \mathbf{1}_{\{t<0\}}$. It is easy to check that the process B indeed codes for the tree $\mathcal{F}_{(-\infty, 0]}$.

4.2.2. *The ancestral process.* Let $(L_t^\ell, t \geq 0)$ be the local time at 0 of the process B^ℓ , where $\ell \in \{g, d\}$. We denote by $((\alpha_i, \beta_i), i \in \mathcal{I}^\ell)$ the excursion intervals of B^ℓ under 0, omitting the last infinite excursion if any, and, for every $i \in \mathcal{I}^\ell$, we set $\zeta_i = -\min\{B_s^\ell, s \in (\alpha_i, \beta_i)\}$.

We consider the point measure on $\mathbb{R} \times \mathbb{R}_+$ defined by:

$$\mathcal{A}^\mathcal{N}(du, d\zeta) = \sum_{i \in \mathcal{I}^d} \delta_{(L_{\alpha_i}^d, \zeta_i)}(du, d\zeta) + \sum_{i \in \mathcal{I}^g} \delta_{(-L_{\alpha_i}^g, \zeta_i)}(du, d\zeta).$$

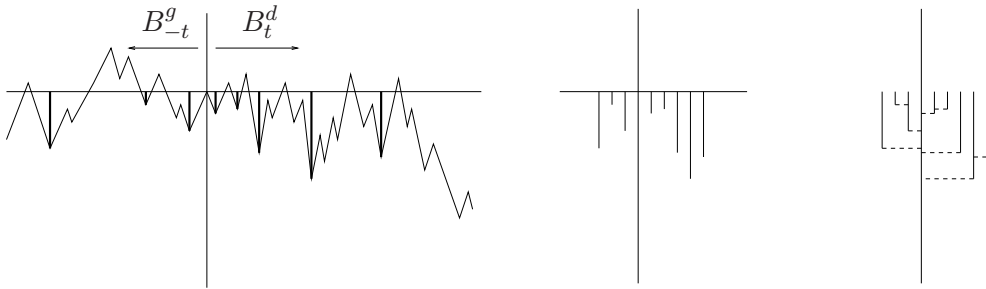

FIGURE 3. The Brownian motions with drift, the ancestral process and the associated genealogical tree

Let $[-E_g, E_d]$ be the closed support of the measure $\mathcal{A}^\mathcal{N}(du, \mathbb{R}_+)$:

$$E_d = \inf\{u \geq 0, \mathcal{A}([u, +\infty) \times \mathbb{R}_+) = 0\} \quad \text{and} \quad E_g = \inf\{u \geq 0, \mathcal{A}((-\infty, -u] \times \mathbb{R}_+) = 0\},$$

with the convention that $\inf \emptyset = +\infty$. We now give the distribution of the ancestral process $\mathcal{A}^\mathcal{N}$. Recall c_θ defined by (5).

Proposition 4.6. *Let $\theta \geq 0$. Under $\mathbb{P}^{(\theta)}$, the random variables E_g, E_d are independent and exponentially distributed with parameter 2θ (and mean $1/2\theta$) with the convention that $E_d = E_g = +\infty$ if $\theta = 0$. Under $\mathbb{P}^{(\theta)}$ and conditionally given (E_g, E_d) , the ancestral process $\mathcal{A}^\mathcal{N}(du, d\zeta)$ is a Poisson point measure with intensity:*

$$\mathbf{1}_{(-E_g, E_d)}(u) du |c'_\theta(\zeta)| d\zeta.$$

Notice that the random measure $\mathcal{A}^\mathcal{N}$ satisfies Conditions (i)-(iii) from Definition 4.1 and is thus indeed an ancestral process.

Proof. Since B^d and B^g are independent with the same distribution, we deduce that E_g and E_d are independent with the same distribution. Let $\theta > 0$. Since B^d is a Brownian motion with drift -2θ , we deduce from [6], page 90, that E_d is exponential with mean $1/2\theta$. The case $\theta = 0$ is immediate.

The excursions below zero of B^d conditionally given E_d are excursions of a Brownian motion $B^{(-\theta)}$ with drift 2θ (after symmetry with respect to 0) conditioned on being finite, that is excursions of a Brownian motion $B^{(\theta)}$ with drift -2θ . Moreover, by (5), c_θ is exactly the tail distribution of the maximum of an excursion under $n^{(\theta)}$. Standard theory of Brownian excursions gives then the result. \square

Remark 4.7. Essentially, we use in the proof of Proposition 4.6 that the excursion processes of B above or under 0 have the same distribution. Hence, this proposition can also be viewed as a consequence of Corollary 3.12 together with Proposition 3.9 to take into account the labeling by the local time at 0.

4.2.3. *Identification of the trees.* Let $\mathfrak{T}^{\mathcal{N}} = \mathfrak{T}(\mathcal{A}^{\mathcal{N}})$ denote the locally compact tree associated with the ancestral process $\mathcal{A}^{\mathcal{N}}$ as described in Subsection 4.1. According to the following proposition, we shall say that the ancestral process $\mathcal{A}^{\mathcal{N}}$ codes for the genealogical tree of the extant population at time 0 for the forest \mathcal{F} .

Proposition 4.8. *Let $\theta \geq 0$. The trees $\mathcal{G}_0(\mathcal{F})$ under $\mathbb{P}^{(\theta)}$ and $\mathfrak{T}^{\mathcal{N}}$ belong to the same equivalence class in \mathbb{T}_1 .*

Proof. Let us first remark that the genealogical tree $\mathcal{G}_0(\mathcal{F})$ can be directly constructed using the process B as described on Figure 4.

More precisely, recall that B is the contour function of the tree $\mathcal{F}_{(-\infty,0]}$. Let us denote by p_B the canonical projection from \mathbb{R} to $\mathcal{F}_{(-\infty,0]}$ as defined in Section 2.4. Then $\mathcal{G}_0(\mathcal{F})$ is the smallest complete sub-tree of $\mathcal{F}_{(-\infty,0]}$ that contains the points $(p_B(\alpha_i), i \in \mathcal{I}_0)$ and the infinite branch of $\mathcal{F}_{(-\infty,0]}$.

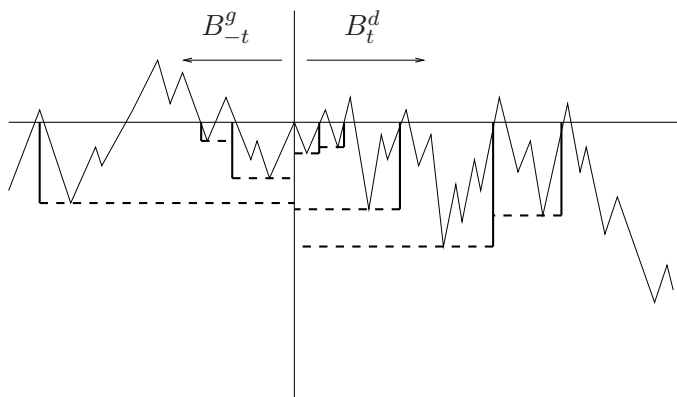

FIGURE 4. The genealogical tree inside the Brownian motions

Let $i, j \in \mathcal{I}$ with $0 < \alpha_i < \alpha_j$ for instance.

By definition of the tree coded by a function, the distance between $p_B(\alpha_i)$ and $p_B(\alpha_j)$ in $\mathcal{G}_0(\mathcal{F})$ is given by

$$d(p_B(\alpha_i), p_B(\alpha_j)) = -2 \min_{u \in [\alpha_i, \alpha_j]} B_u.$$

But, by definition of \mathcal{A} , we have

$$\begin{aligned} - \min_{u \in [\alpha_i, \alpha_j]} B_u &= \max_{k \in \mathcal{I} \alpha_i \leq \alpha_k < \alpha_j} \left(- \min_{u \in [\alpha_k, \beta_k]} B_u \right) \\ &= \max_{k \in \mathcal{I} \alpha_i \leq \alpha_k < \alpha_j} (\zeta_k). \end{aligned}$$

The other cases $\alpha_j < \alpha_i < 0$ and $\alpha_i < 0 < \alpha_j$ can be handled similarly. We deduce that the distances on a dense subset of leaves of $\mathcal{G}_0(\mathcal{F})$ and $\mathfrak{T}^{\mathcal{N}}$ coincide, which implies the result by completeness of the trees. □

5. SIMULATION OF THE GENEALOGICAL TREE ($\theta > 0$)

We use the representation of trees using ancestral process, see Section 4, which is an atomic measure on $\mathbb{R}^* \times (0, +\infty)$ satisfying conditions of Definition 4.1.

Under $\mathbb{P}^{(\theta)}$, let $\sum_{i \in I} \delta_{(h_i, \varepsilon_i, e_i)}$ be a Poisson point measure on $\mathbb{R} \times \{-1, 1\} \times \mathcal{E}$ with intensity $\beta dh (\delta_{-1}(d\varepsilon) + \delta_1(d\varepsilon)) n^{(\theta)}(de)$, and let $\mathcal{F} = ((h_i, \tau_i), i \in I)$ be the associated Brownian forest. We denote by $\ell_a^{(i)}$ the local time measure of the tree τ_i at level a (recall that this local time is zero for $a \notin [0, H(\tau_i)]$). Recall the extant population at time $h \in \mathbb{R}$ is given by $\mathcal{Z}_h(\mathcal{F})$ defined in Section 2.4.4 and the measure \mathbf{Z}_h on $\mathcal{Z}_h(\mathcal{F})$ is defined by (14).

Let $(X_k, k \in \mathbb{N}^*)$ be, conditionally given \mathcal{F} , independent random variables distributed according to the probability measure \mathbf{Z}_0/Z_0 . For every $k \in \mathbb{N}^*$, we set i_k the index in I such that $X_k \in \tau_{i_k}$ and we denote by ∂_k the root of τ_{i_k} . Recall that ∂_k is identified with $h_k \in (-\infty, 0]$ on \mathbb{R} which corresponds to the immortal lineage. We define the genealogical tree T_n of n individuals sampled at random among the population at time 0 by:

$$T_n = (-\infty, 0] \otimes_{1 \leq k \leq n} ([\partial_k, X_k], h_k).$$

We distinguish the vertex 0 in T_n and precise its height to be 0 so that T_n can be viewed as a \mathbb{T}_1 -valued random variable. Notice that $T_n \subset T_{n+1}$. Since the support of \mathbf{Z}_h is $\mathcal{Z}_h(\mathcal{F})$ a.s., we get that a.s. $\text{cl}(\bigcup_{n \in \mathbb{N}^*} T_n) = \mathcal{G}_0(\mathcal{F})$, where $\mathcal{G}_0(\mathcal{F})$, see Definition (6), is the genealogical tree of the forest \mathcal{F} at time 0.

Recall c_θ defined by (5). For $\delta > 0$, we will consider in the next sections a positive random variable ζ_δ^* whose distribution is given by, for $h > 0$:

$$(19) \quad \mathbb{P}(\zeta_\delta^* < h) = e^{-\delta c_\theta(h)}.$$

This random variable is easy to simulate as, if U is uniformly distributed on $[0, 1]$, then ζ_δ^* has the same distribution as:

$$\frac{1}{2\theta\beta} \log \left(1 - \frac{2\theta\delta}{\log(U)} \right).$$

This random variable appears naturally in the simulation of the ancestral process of \mathcal{F} as, if $\sum_{i \in I} \delta_{(z_i, \zeta_i)}$ is a Poisson point measure on $\mathbb{R} \times \mathbb{R}_+$ with intensity $\mathbf{1}_{[0, \delta]}(z) dz |c'_\theta(\zeta)| d\zeta$ (see Proposition 4.6 for the interpretation), then ζ_δ^* is distributed as $\max_{i \in I} \zeta_i$.

We now present many ways to simulate T_n . This will be done by simulating ancestral processes, see Section 4 which code for trees distributed as T_n .

Recall that for an interval I , we write $|I|$ for its length.

5.1. Static simulation. Assume $n \in \mathbb{N}^*$ is fixed. We present a way to simulate T_n under $\mathbb{P}^{(\theta)}$ with $\theta > 0$. See Figures 5 and 6 for an illustration for $n = 5$.

- (i) The size of the population on the left (resp. right) of the origin is E_g (resp. E_d), where E_g, E_d are independent exponential random variables with mean $1/2\theta$. Set $Z_0 = E_g + E_d$ for the total size of the population at time 0. Let $(U_k, k \in \mathbb{N}^*)$ be independent random variables uniformly distributed on $[0, 1]$ and independent of (E_g, E_d) . Set $X_0 = 0$, and, for $k \in \mathbb{N}^*$, $X_k = Z_0 U_k - E_g$ as well as $\mathcal{X}_k = \{-E_g, E_d, X_0, \dots, X_k\}$.
- (ii) For $1 \leq k \leq n$, set $X_{k,n}^g = \max\{x \in \mathcal{X}_n, x < X_k\}$ and $X_{k,n}^d = \min\{x \in \mathcal{X}_n, x > X_k\}$. We also set $I_k^S = [X_{k,n}^g, X_k]$ if $X_k > 0$ and $I_k^S = [X_k, X_{k,n}^d]$ if $X_k < 0$.
- (iii) Conditionally on $(E_g, E_d, X_1, \dots, X_n)$, let $(\zeta_k^S, 1 \leq k \leq n)$ be independent random variables such that for $1 \leq k \leq n$, ζ_k^S is distributed as ζ_δ^* , see (19), with $\delta = |I_k^S|$. Consider the tree \mathfrak{T}_n^S corresponding to the ancestral process $\mathcal{A}_n^S = \sum_{k=1}^n \delta_{(X_k, \zeta_k^S)}$.

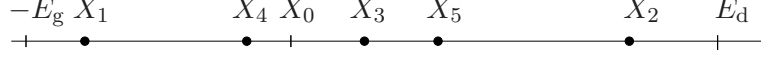
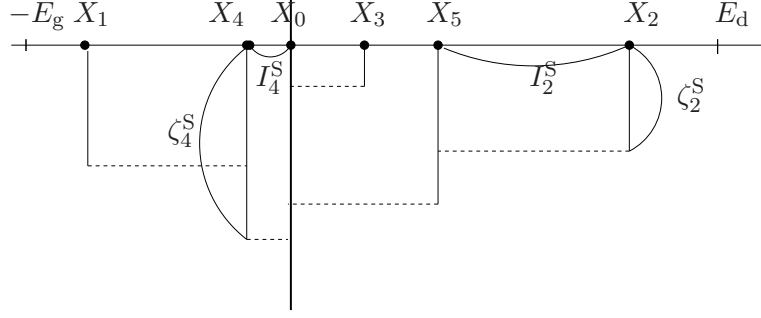
 FIGURE 5. One realization of $E_g, E_d, X_1, \dots, X_5$.

 FIGURE 6. One realization of the tree \mathfrak{T}_5^S .

The following result is a direct consequence of Proposition 4.8 and Proposition 4.6 and the construction of the tree \mathfrak{T} given in Section 4.1.

Lemma 5.1. *Let $\theta > 0$ and $n \in \mathbb{N}^*$. The tree \mathfrak{T}_n^S is distributed as T_n under $\mathbb{P}^{(\theta)}$.*

5.2. Dynamic simulation (I). We can modify the static simulation of the previous section to provide a natural dynamic construction of the genealogical tree. Let $\theta > 0$. We build recursively a family of ancestral processes $(\mathcal{A}_n, n \in \mathbb{N})$, with $\mathcal{A}_0^D = 0$ and $\mathcal{A}_n^D = \sum_{k=1}^n \delta_{(V_k, \zeta_k^D)}$ for $n \in \mathbb{N}^*$.

- (i) Let $E_g, E_d, (X_n, n \in \mathbb{N})$ and $(\mathcal{X}_n, n \in \mathbb{N}^*)$ be defined as in (i) of Section 5.1. For $n \in \mathbb{N}^*$, set $X_n^g = \max\{x \in \mathcal{X}_n, x < X_n\}$ and $X_n^d = \min\{x \in \mathcal{X}_n, x > X_n\}$.

For $n \in \mathbb{N}^*$ and $\ell \in \{g, d\}$, define the interval $I_n^\ell = [X_n \wedge X_n^\ell, X_n \vee X_n^\ell]$ and its length $|I_n^\ell| = |X_n - X_n^\ell|$.

We shall consider and check by the induction the following hypothesis: for $n \geq 2$ the random variables V_1, \dots, V_{n-1} are such that

$$(20) \quad X_{(0,n-1)} < V_{(1,n-1)} < X_{(1,n-1)} < \dots < V_{(n-1,n-1)} < X_{(n-1,n-1)},$$

where $(V_{(1,n-1)}, \dots, V_{(n,n)})$ and $(X_{(0,n-1)}, \dots, X_{(n-1,n-1)})$ respectively are the order statistics of (V_1, \dots, V_{n-1}) and of (X_0, \dots, X_{n-1}) respectively. Notice that (20) holds trivially for $n = 1$.

We set $\mathcal{W}_n^D = (E_g, E_d, X_1, \dots, X_n, V_1, \dots, V_{n-1}, \zeta_1^D, \dots, \zeta_{n-1}^D)$.

- (ii) Assume $n \geq 1$. We work conditionally on \mathcal{W}_n^D . On the event $\{X_n^d = E_d\}$ set $I_n = I_n^g$ and on the event $\{X_n^g = -E_g\}$ set $I_n = I_n^d$. On the event $\{X_n^d = E_d\} \cup \{X_n^g = -E_g\}$, let V_n be uniform on I_n and ζ_n^D be distributed as ζ_δ^* , see (19), with $\delta = |I_n|$.
- (iii) Assume $n \geq 2$ and that (20) holds. We work conditionally on \mathcal{W}_n^D . On the event $\{-E_g < X_n^g, X_n^d < E_d\}$, there exists a unique integer $\kappa_n \in \{1, \dots, n-1\}$ such that $V_{\kappa_n} \in [X_n^g, X_n^d]$. If $X_n \in [X_n^g, V_{\kappa_n})$, set $I_n = I_n^g$; and if $X_n \in [V_{\kappa_n}, X_n^d]$, set $I_n = I_n^d$. On the set $\{-E_g < X_n^g, X_n^d < E_d\}$, let V_n be uniform on I_n and ζ_n^D be distributed as ζ_δ^* , with $\delta = |I_n|$, conditionally on being less than $\zeta_{\kappa_n}^D$.

(iv) Thanks to (ii) and (iii), notice that (20) holds with $n - 1$ replaced by n , so that the induction is valid. Set $\mathcal{A}_n^D = \mathcal{A}_{n-1}^D + \delta_{(V_n, \zeta_n^D)}$ and consider the tree \mathfrak{T}_n^D corresponding to the ancestral process \mathcal{A}_n^D .

See Figures 7 and 8 for an instance of \mathfrak{T}_4^D and \mathfrak{T}_5^D .

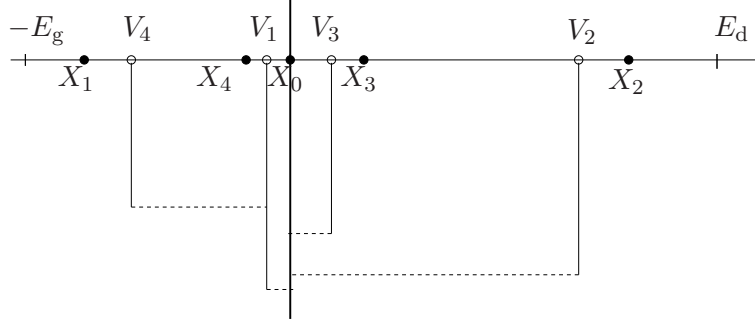

FIGURE 7. An instance of the tree \mathfrak{T}_4^D .

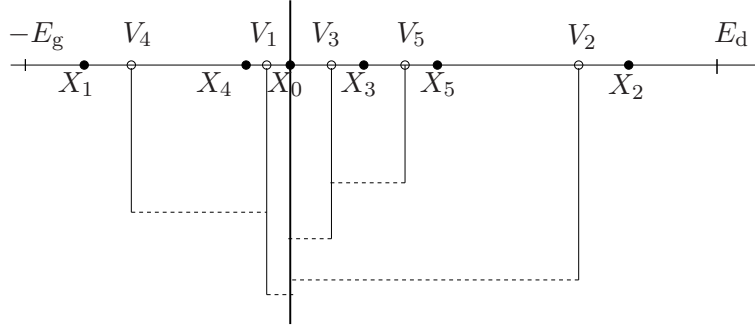

FIGURE 8. An instance of the tree \mathfrak{T}_5^D . The length of the new branch attached to V_5 is conditioned to be less than the previous branch that was in the considered interval attached to V_2

Then we have the following result.

Lemma 5.2. *Let $\theta > 0$. The sequences of trees $(\mathfrak{T}_n^D, n \in \mathbb{N}^*)$ and $(T_n, n \in \mathbb{N}^*)$ under $\mathbb{P}^{(\theta)}$ have the same distribution.*

Proof. We consider $\sum_{i \in I} \delta_{(u_i, \zeta_i)}$ the ancestral process associated to the Poisson point measure $\sum_{i \in I} \delta_{(h_i, \varepsilon_i, e_i)}$ defined in Section 4. Let $(X''_k, k \in \mathbb{N}^*)$ be independent uniform random variables on $[-E_g, E_d]$. Set $X''_0 = 0$. For $n \geq 1$, let us denote by $(X''_{(k,n)}, 0 \leq k \leq n)$ the order statistic of (X''_0, \dots, X''_n) .

For every $n \geq 1$ and every $1 \leq k \leq n$, we set $i_{k,n}$ the index in I such that

$$\zeta_{i_{k,n}} = \max_{X''_{(k-1,n)} \leq t_i < X''_{(k,n)}} \zeta_i.$$

Remark that this index exists since, for every $\varepsilon > 0$, the set $\{i \in I, \zeta_i > \varepsilon\}$ is a.s. finite. We set $V''_{(k,n)} = u_{i_{k,n}}$ and define

$$\mathcal{A}''_n = \sum_{k=1}^n \delta_{(V''_{(k,n)}, \zeta_{i_{k,n}})}.$$

By construction, it is easy to check that the order statistics

$$X''_{(0,n)} < V''_{(1,n)} < X''_{(1,n)} < \cdots < V''_{(n,n)} < X''_{(n,n)}$$

is distributed as

$$X_{(0,n)} < V_{(1,n)} < X_{(1,n)} < \cdots < V_{(n,n)} < X_{(n,n)}.$$

For $1 \leq k \leq n$, let $j_{k,n} \in \{1, \dots, n\}$ be the index such that $V_{(k,n)} = V_{j_{k,n}}$. By construction, we then deduce that $((V_{(k,n)}, \zeta_{j_{k,n}}^D), 1 \leq k \leq n), n \in \mathbb{N}^*$ is distributed as $((V''_{(k,n)}, \zeta_{i_{k,n}}), 1 \leq k \leq n), n \in \mathbb{N}^*$. This implies that the sequence of ancestral processes $(\mathcal{A}''_n, n \in \mathbb{N}^*)$ and $(\mathcal{A}_n, n \in \mathbb{N}^*)$ have the same distribution. Then use Proposition 4.8 to get that the sequence of trees $(T''_n, n \in \mathbb{N}^*)$, with T''_n associated to \mathcal{A}''_n , is distributed as $(T_n, n \in \mathbb{N}^*)$. \square

5.3. Dynamic simulation (II). In a sense, we had to introduce another random information corresponding to the position V_n of the largest spine of the sub-tree containing X_n . The construction in this sub-section provides a way to remove this additional information (which is now Hidden) but at the expense to possibly exchange the new inserted branch with one of its neighbor. An instance is provided for \mathfrak{T}_4^H and \mathfrak{T}_5^H in Figures 9, 10 and 11.

Let $\theta > 0$. We build recursively a family of ancestral processes $(\mathcal{A}_n, n \in \mathbb{N})$, with $\mathcal{A}_0^H = 0$ and $\mathcal{A}_n^H = \sum_{k=1}^n \delta_{(X_k, \zeta_{k,n}^H)}$ for $n \in \mathbb{N}^*$.

- (i) Let $E_g, E_d, (X_n, n \in \mathbb{N})$ and $(\mathcal{X}_n, n \in \mathbb{N}^*)$ be defined as in (i) of Section 5.1. For $n \in \mathbb{N}^*$, set $X_n^g = \max\{x \in \mathcal{X}_n, x < X_n\}$ and $X_n^d = \min\{x \in \mathcal{X}_n, x > X_n\}$. For $n \in \mathbb{N}^*$ and $\ell \in \{g, d\}$, define the interval $I_n^\ell = [X_n \wedge X_n^\ell, X_n \vee X_n^\ell]$ and its length $|I_n^\ell| = |X_n - X_n^\ell|$. We set $\mathcal{W}_n^H = (E_g, E_d, X_1, \dots, X_n, \zeta_{1,n-1}^H, \dots, \zeta_{n-1,n-1}^H)$.
- (ii) Assume $n \geq 1$. On the event $\{X_n^d = E_d\}$ set $I_n = I_n^g$ and on the event $\{X_n^g = -E_g\}$ set $I_n = I_n^d$. Conditionally on \mathcal{W}_n^H , let $\zeta_{n,n}^H$ be distributed as ζ_δ^* , see (19), with $\delta = |I_n|$; and for $1 \leq k \leq n-1$, set $\zeta_{k,n}^H = \zeta_{k,n-1}^H$.
- (iii) Assume $n \geq 2$. We work conditionally on \mathcal{W}_n^H . We define:

$$p_d = \frac{|I_n^d|}{|I_n^d| + |I_n^g|} \quad \text{and} \quad p_g = 1 - p_d = \frac{|I_n^g|}{|I_n^d| + |I_n^g|}.$$

- (a) On the event $\{0 \leq X_n^g, X_n^d < E_d\}$, there exists a unique integer $\kappa_n^d \in \{1, \dots, n-1\}$ such that $X_{\kappa_n^d} = X_n^d$. For $1 \leq k \leq n-1$ and $k \neq \kappa_n^d$, set $\zeta_{n,k}^H = \zeta_{n-1,k}^H$. Write $\zeta_n^H = \zeta_{n-1, \kappa_n^d}^H$. With probability p_d , set $\zeta_{n, \kappa_n^d}^H = \zeta_n^H$ and let $\zeta_{n,n}^H$ be distributed as ζ_δ^* , with $\delta = |I_n^g|$, conditionally on being less than ζ_n^H . With probability p_g , set $\zeta_{n,n}^H = \zeta_n^H$ and let $\zeta_{n, \kappa_n^d}^H$ be distributed as ζ_δ^* , with $\delta = |I_n^d|$, conditionally on being less than ζ_n^H .
- (b) On the event $\{-E_g < X_n^g, X_n^d \leq 0\}$, there exists a unique integer $\kappa_n^g \in \{1, \dots, n-1\}$ such that $X_{\kappa_n^g} = X_n^g$. For $1 \leq k \leq n-1$ and $k \neq \kappa_n^g$, set $\zeta_{n,k}^H = \zeta_{n-1,k}^H$. Write $\zeta_n^H = \zeta_{n-1, \kappa_n^g}^H$.

With probability p_g , set $\zeta_{n,\kappa_n^g}^H = \zeta_n^H$ and let $\zeta_{n,n}^H$ be distributed as ζ_δ^* , with $\delta = |I_n^d|$, conditionally on being less than ζ_n^H .

With probability p_d , set $\zeta_{n,n}^H = \zeta_n^H$ and let $\zeta_{n,\kappa_n^g}^H$ be distributed as ζ_δ^* , with $\delta = |I_n^g|$, conditionally on being less than ζ_n^H .

(iv) Let \mathfrak{T}_n^H be the tree corresponding to the ancestral process $\mathcal{A}_n^H = \sum_{k=1}^n \delta_{(X_k, \zeta_{k,n}^H)}$.

We have the next result.

Lemma 5.3. *Let $\theta > 0$. The sequences of trees $(\mathfrak{T}_n^H, n \in \mathbb{N}^*)$ and $(T_n, n \in \mathbb{N}^*)$ under $\mathbb{P}^{(\theta)}$ have the same distribution.*

Proof. The proof is left to the reader. It is in the same spirit as the proof of Lemma 5.2, but here we consider the random variables $((V''_{(k,n)}, 1 \leq k \leq n), n \in \mathbb{N}^*)$ as unobserved. \square

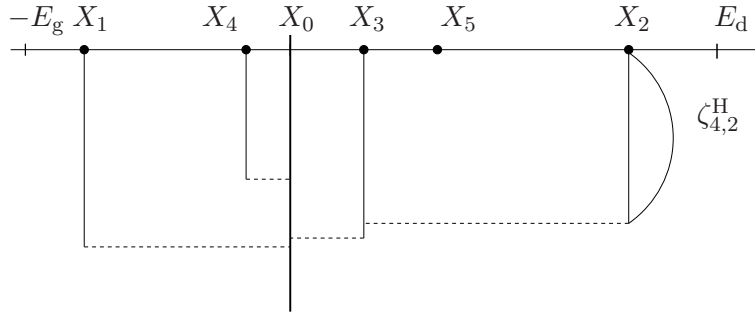

FIGURE 9. An instance of the tree \mathfrak{T}_4^H with the new individual X_5 .

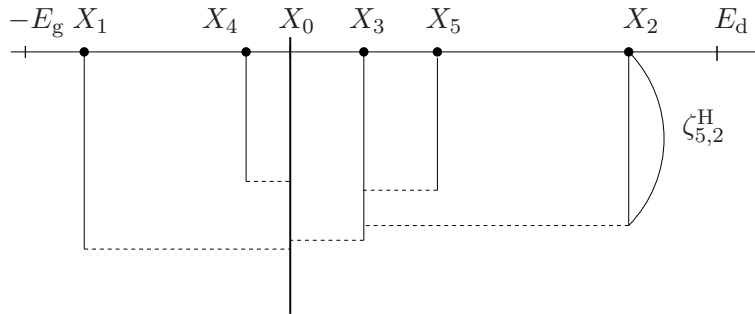

FIGURE 10. An instance of the tree \mathfrak{T}_5^H with \mathfrak{T}_4^H given in Figure 9 and the event associated with p_d (a new segment is attached to X_5).

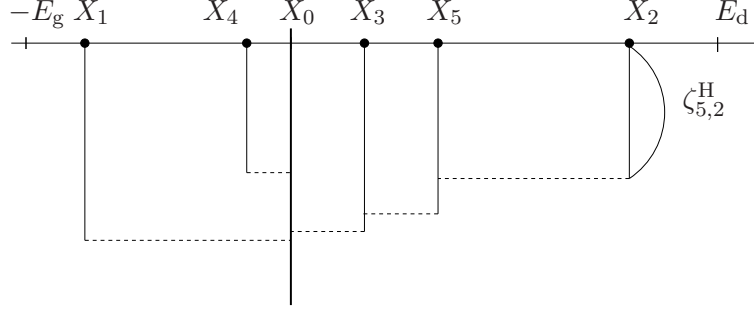

FIGURE 11. An instance of the tree \mathfrak{T}_5^H with \mathfrak{T}_4^H given in Figure 9 and the event associated with p_g (the segment previously attached to X_2 is now attached to X_5 and a new segment is attached to X_2).

5.4. Simulation of genealogical tree conditionally on its maximal height. Let $\mathcal{F} = ((\tau_i, h_i), i \in I)$ be a Brownian forest under $\mathbb{P}^{(\theta)}$. Recall the definition of A_0 the time to the MRCA of the population living at time 0 given in (12). The goal of this section is to simulate the genealogical tree T_n of n individuals uniformly sampled in the population living at time 0, conditionally given the time to the MRCA of the whole population is h , that is given $A_0 = h$.

Let $\mathcal{A}(du, d\zeta) = \sum_{j \in J} \delta_{(u_j, \zeta_j)}(du, d\zeta)$ be the ancestral process of Definition 4.1. Recall the notations E_g, E_d from Proposition 4.2.2. Let $\zeta_{\max} = \sup\{\zeta_j, j \in J\}$ and define the random index $J_0 \in I$ such that $\zeta_{\max} = \zeta_{J_0}$. Note that J_0 is well defined since for every $\varepsilon > 0$, the set $\{j \in I, \zeta_j > \varepsilon\}$ is finite. We set $X = u_{J_0} \in (-E_g, E_d)$. Remark that ζ_{\max} is distributed as A_0 .

For $r \in \mathbb{R}$, let $r_+ = \max(0, r)$ and $r_- = \max(0, -r)$ be respectively the positive and negative part of r . The proof of the next lemma is postponed to the end of this section.

Lemma 5.4. *Let $\theta > 0$. Under $\mathbb{P}^{(\theta)}$, conditionally given $\zeta_{\max} = h$, the random variables $E_g + X_-$, $|X|$, $E_d - X_+$ and $\mathbf{1}_{\{X \geq 0\}}$ are independent; $E_g + X_-$, $|X|$ and $E_d - X_+$ are exponentially distributed with parameter $2\theta + c_\theta(h)$ and $\mathbf{1}_{\{X \geq 0\}}$ is Bernoulli $1/2$.*

Let $h > 0$ be fixed. For $\delta > 0$, let $\zeta_\delta^{*,h}$ be a positive random variable distributed as ζ_δ^* conditionally on $\{\zeta_\delta^* \leq h\}$, i.e., for $0 \leq u \leq h$:

$$\mathbb{P}(\zeta_\delta^{*,h} \leq u) = \mathbb{P}(\zeta_\delta^* \leq u \mid \zeta_\delta^* \leq h) = e^{-\delta(c_\theta(x) - c_\theta(h))}.$$

Then the static simulation runs as follows.

- (i) Simulate three independent random variables E_1, E_2, E_3 exponentially distributed with parameter $2\theta + c_\theta(h)$, and another independent Bernoulli variable ξ with parameter $1/2$. If $\xi = 0$, set $E_g = E_1$, $X = E_2$, $E_d = E_2 + E_3$, and if $\xi = 1$, set $E_g = E_1 + E_2$, $X = -E_2$, $E_d = E_3$. Let X_k and \mathcal{X}_k be defined as in (i) of Section 5.1 for $1 \leq k \leq n$.
- (ii) Let the intervals I_k^S be defined as in (ii) of Section 5.1 for $1 \leq k \leq n$.
- (iii) Conditionally on $(E_g, E_d, X, X_1, \dots, X_n)$, let $(\zeta_k^h, 1 \leq k \leq n)$ be independent random variables such that, for $1 \leq k \leq n$, ζ_k^h is distributed as $\zeta_\delta^{*,h}$ with $\delta = |I_k^S|$ if $X \notin I_k^S$; and $\zeta_k^h = h$ if $X \in I_k^S$. Consider the tree \mathfrak{T}_n^h corresponding to the ancestral process $\mathcal{A}_n^h = \sum_{k=1}^n \delta_{(X_k, \zeta_k^h)}$.

The proof of the following result which relies on Lemma 5.4 is similar to the one of Lemma 5.1.

Lemma 5.5. *Let $\theta > 0$, $h > 0$ and $n \in \mathbb{N}^*$. The tree \mathfrak{T}_n^h is distributed as T_n under $\mathbb{P}^{(\theta)}$ conditionally given $A_0 = h$.*

Notice that the height of \mathfrak{T}_n^h is less than equal to h . When strictly less than h , it means that no individual of the oldest family has been sampled.

Proof of Lemma 5.4. By Proposition 4.6, the pair $E = (E_g, E_d)$ under $\mathbb{P}^{(\theta)}$ has density:

$$f_E(e_g, e_d) = (2\theta)^2 e^{-2\theta(e_g+e_d)} \mathbf{1}_{\{e_g \geq 0, e_d \geq 0\}}.$$

Moreover, by standard results on Poisson point measures, the conditional density given $(E_d, E_g) = (e_g, e_d)$ of the pair (X, ζ_{\max}) exits and is:

$$\begin{aligned} f_{X, \zeta_{\max}}^{E=(e_g, e_d)}(x, h) &= \frac{1}{e_g + e_d} \mathbf{1}_{[-e_g, e_d]}(x) (e_g + e_d) |c'_\theta(h)| e^{-c_\theta(h)(e_g+e_d)} \mathbf{1}_{\{h \geq 0\}} \\ &= \mathbf{1}_{[-e_g, e_d]}(x) |c'_\theta(h)| e^{-c_\theta(h)(e_g+e_d)} \mathbf{1}_{\{h \geq 0\}}. \end{aligned}$$

We deduce that the vector $(E_g, E_d, X, \zeta_{\max})$ has density:

$$f(e_g, e_d, x, h) = (2\theta)^2 |c'_\theta(h)| e^{-(2\theta+c_\theta(h))(e_g+e_d)} \mathbf{1}_{\{e_g \geq 0, e_d \geq 0, -e_g \leq x \leq e_d, h \geq 0\}}$$

and that the random variable ζ_{\max} has density:

$$\begin{aligned} f_{\zeta_{\max}}(h) &= \int (2\theta)^2 |c'_\theta(h)| e^{-(2\theta+c_\theta(h))(e_g+e_d)} \mathbf{1}_{\{e_g \geq 0, e_d \geq 0, -e_g \leq x \leq e_d, h \geq 0\}} de_g de_d dx \\ &= (2\theta)^2 |c'_\theta(h)| \frac{2}{(2\theta + c_\theta(h))^3} \mathbf{1}_{\{h \geq 0\}}. \end{aligned}$$

Therefore, the conditional density of the vector (E_g, E_d, X) given $\zeta_{\max} = h$ is:

$$f_{E, X}^{\zeta_{\max}=h}(e_g, e_d, x) = \frac{1}{2} (2\theta + c_\theta(h))^3 e^{-(2\theta+c_\theta(h))(e_g+e_d)} \mathbf{1}_{\{e_g \geq 0, e_d \geq 0, -e_g \leq x \leq e_d\}}.$$

For any nonnegative measurable function φ , we have:

$$\begin{aligned} \mathbb{E}^{(\theta)}[\varphi(E_g + X_-, |X|, E_d - X_+) \mathbf{1}_{\{X \geq 0\}} \mid \zeta_{\max} = h] \\ &= \mathbb{E}^{(\theta)}[\varphi(E_g, X, E_d - X) \mathbf{1}_{\{X \geq 0\}} \mid \zeta_{\max} = h] \\ &= \int \varphi(e_g, x, e_d - x) \frac{1}{2} (2\theta + c_\theta(h))^3 e^{-(2\theta+c_\theta(h))(e_g+e_d)} \mathbf{1}_{\{e_g \geq 0, e_d \geq x \geq 0\}} de_g de_d dx \\ &= \int \varphi(e_1, e_2, e_3) \frac{1}{2} (2\theta + c_\theta(h))^3 e^{-(2\theta+c_\theta(h))(e_1+e_2+e_3)} \mathbf{1}_{\{e_1 \geq 0, e_2 \geq 0, e_3 \geq 0\}} de_1 de_2 de_3, \end{aligned}$$

using an obvious change of variables. Similarly, we get:

$$\begin{aligned} \mathbb{E}^{(\theta)}[\varphi(E_g + X_-, |X|, E_d - X_+) \mathbf{1}_{\{X < 0\}} \mid \zeta_{\max} = h] \\ &= \mathbb{E}^{(\theta)}[\varphi(E_g + X_-, |X|, E_d - X_+) \mathbf{1}_{\{X \geq 0\}} \mid \zeta_{\max} = h]. \end{aligned}$$

This proves the lemma. \square

6. PROOF OF PROPOSITION 3.13

6.1. Setting for the reversed forest. Let E_g and E_d be two independent exponential random variable with parameter 2θ . Let $\mathcal{N} = \sum_{i \in I} \delta_{z_i, \tau_i}$ be, conditionally given (E_g, E_d) , distributed as a Poisson point measure with intensity $\mathbf{1}_{[-E_g, E_d]}(z) dz \mathbb{N}^{(\theta)}[d\tau]$. We define $\tilde{L} = (\tilde{L}_\varepsilon, \varepsilon > 0)$ with:

$$\tilde{L}_\varepsilon = \sum_{i \in I} (\zeta_i - \varepsilon)_+,$$

where $\zeta_i = H(\tau_i)$ is the height of τ_i . Let $(U_k, k \in \mathbb{N}^*)$ be independent random variables uniformly distributed on $[0, 1]$ and independent of (\mathcal{N}, E_g, E_d) . We set $X_0 = 0$, and $X_k = (E_g + E_d)U_k - E_g$

for $k \in \mathbb{N}^*$. Fix $n \in \mathbb{N}^*$. Let $X_{(0,n)} \leq \dots \leq X_{(n,n)}$ be the corresponding order statistic of (X_0, \dots, X_n) . We set $X_{(-1,n)} = -E_g$ and $X_{(n+1,n)} = E_d$. We define the interval $I_{k,n} = (X_{(k-1,n)}, X_{(k,n)})$ and its length $\Delta_{k,n} = X_{(k,n)} - X_{(k-1,n)}$ for $0 \leq k \leq n+1$. We set $\tilde{\Delta}_n = (\Delta_{k,n}, 0 \leq k \leq n+1)$. For $1 \leq k \leq n$, we define $\tilde{\Lambda} = (\tilde{\Lambda}_n, n \in \mathbb{N}^*)$ by:

$$\tilde{\Lambda}_n = \sum_{k=1}^n \zeta_{k,n}^*, \quad \text{with} \quad \zeta_{k,n}^* = \max\{\zeta_i; z_i \in I_{k,n}\}.$$

Recall the definitions of Z_0 in (11), $L = (L_\varepsilon, \varepsilon > 0)$ in (13) and $\Lambda = (\Lambda_n, n \in \mathbb{N}^*)$ in (15). Thanks to Corollary 3.12, we deduce that (Z_0, L, Λ) is distributed as $(E_g + E_d, \tilde{L}, \tilde{\Lambda})$. So to prove Proposition 3.13, it is enough to prove the statement with $\tilde{\Lambda}$ instead of Λ .

For convenience, we set $Z_0 = E_g + E_d$. Elementary computations give the following lemma. Recall that $z_+ = \max(z, 0)$.

Lemma 6.1. *Let $\varepsilon > 0$. We have:*

$$(21) \quad \mathbb{N}[(\zeta - \varepsilon)_+] = \int_\varepsilon^\infty c_\theta(h) dh = -\frac{1}{\beta} \log(2\beta\theta\varepsilon) + O(\varepsilon),$$

$$(22) \quad \mathbb{N}[(\zeta - \varepsilon)_+^2] = 2 \int_\varepsilon^\infty hc_\theta(h) dh - 2\varepsilon \int_\varepsilon^\infty c_\theta(h) dh = 2 \int_0^\infty hc_\theta(h) dh + O(\varepsilon \log(\varepsilon)).$$

We deduce that:

$$(23) \quad \mathbb{E}[\tilde{L}_\varepsilon | Z_0] = -\frac{Z_0}{\beta} \log(2\beta\theta\varepsilon) + O(\varepsilon),$$

$$(24) \quad \mathbb{E}[\tilde{L}_\varepsilon^2 | Z_0] = 2Z_0 \int_0^\infty hc_\theta(h) dh + \mathbb{E}[\tilde{L}_\varepsilon | Z_0]^2 + O(\varepsilon \log(\varepsilon)),$$

where we used that if $\sum_{i \in I} \delta_{x_i}$ is a Poisson point measure with intensity $\mu(dx)$, then:

$$(25) \quad \mathbb{E} \left[\left(\sum_{i \in I} f(x_i) \right)^2 \right] = \mu(f^2) + \mu(f)^2.$$

Eventually, let us notice that with the change of variable $u = c_\theta(h)$ (so that $dh = du/\beta u(u+2\theta\delta)$), we have:

$$(26) \quad 2 \int_0^\infty hc_\theta(h) dh = \frac{1}{\beta^2\theta} \int_0^\infty \frac{\log(v+1)}{v(v+1)} dv.$$

Recall the definition of ζ_δ^* for $\delta > 0$, see (19). Let γ be the Euler constant, and thus:

$$\gamma = - \int_0^{+\infty} \log(u) e^{-u} du.$$

We have the following lemma.

Lemma 6.2. *Let $\delta > 0$. We have:*

$$(27) \quad \mathbb{E}[\zeta_\delta^*] = -\frac{\delta}{\beta} \log(2\theta\delta) + \frac{\delta}{\beta}(1 - \gamma) + \frac{\delta}{\beta} g_1(2\theta\delta),$$

with $|g_1(x)| \leq x(|\log(x)| + 2)$ for $x > 0$ and

$$(28) \quad \mathbb{E}[(\zeta_\delta^*)^2] = 2\delta \int_0^\infty hc_\theta(h) dh + \frac{\delta}{\beta^2\theta} g_2(2\theta\delta),$$

with $|g_2(x)| \leq x(|\log(x)| + 2)$ for $x > 0$. We also have:

$$(29) \quad \mathbb{E} \left[\zeta_\delta^* \sum_{i \in I} (\zeta_i - \varepsilon)_+ \right] = 2\delta \int_0^\infty hc_\theta(h) dh + g_3(\delta)$$

and there exists a finite constant c such that for all $x > 0$ and $\varepsilon \in (0, 1]$, we have $|g_3(x)| \leq cx^2(1+x)(|\log(x)| + 1)(|\log(\varepsilon)| + 1) + c\varepsilon x(|\log(x)| + 1)(1+x) + \varepsilon^2$.

The end of this section is devoted to the proof of Lemma 6.2.

6.1.1. *Proof of (27)*. Using (19), we get:

$$(30) \quad \mathbb{E}[\zeta_\delta^*] = \int_0^\infty \mathbb{P}(\zeta_\delta^* > h) dh = \int_0^\infty (1 - e^{-\delta c_\theta(h)}) dh = \frac{\delta}{\beta} \int_0^\infty (1 - e^{-u}) \frac{du}{u(u + 2\theta\delta)},$$

where we used the change of variable $u = \delta c_\theta(h)$. It is easy to check that for $a > 0$.

$$(31) \quad \log(1+a) \leq |\log(a)| + \log(2).$$

Let $a > 0$. We have:

$$\begin{aligned} \int_0^1 (1 - e^{-u}) \frac{du}{u(u+a)} &= \int_0^1 (1 - u - e^{-u}) \frac{du}{u(u+a)} + \log(1+a) - \log(a) \\ &= \int_0^1 (1 - u - e^{-u}) \frac{du}{u^2} + \log(1+a) - \log(a) + ag_{1,0}(a), \end{aligned}$$

with

$$g_{1,0}(a) = - \int_0^1 (1 - u - e^{-u}) \frac{du}{u^2(u+a)} \leq \int_0^1 \frac{du}{2(u+a)} = \frac{1}{2}(\log(1+a) - \log(a)) \leq |\log(a)| + \frac{1}{2}$$

and $g_{1,0}(a) \geq 0$, where we used that $0 \leq -(1 - u - e^{-u}) \leq u^2/2$ for $u \geq 0$. We also have:

$$\int_1^\infty (1 - e^{-u}) \frac{du}{u(u+a)} = \int_1^\infty (1 - e^{-u}) \frac{du}{u^2} - ag_{1,1}(a),$$

with

$$g_{1,1}(a) = \int_1^\infty (1 - e^{-u}) \frac{du}{u^2(u+a)} \leq \int_1^\infty \frac{du}{u^3} \leq \frac{1}{2}.$$

Notice that, by integration by parts, we have:

$$\int_0^1 (1 - u - e^{-u}) \frac{du}{u^2} + \int_1^\infty (1 - e^{-u}) \frac{du}{u^2} = e^{-1} + \int_0^1 \log(u) e^{-u} du + 1 - e^{-1} + \int_1^\infty \log(u) e^{-u} du = 1 - \gamma.$$

We deduce that:

$$\int_0^\infty (1 - e^{-u}) \frac{du}{u(u+a)} = 1 - \gamma - \log(a) + g_1(a)$$

with $g_1(a) = \log(1+a) + ag_{1,0}(a) - ag_{1,1}(a)$ and

$$|g_1(a)| = |\log(1+a) + ag_{1,0}(a) - ag_{1,1}(a)| \leq a(|\log(a)| + 2).$$

Then, use (30) to get (27).

6.1.2. *Proof of (28).* Using (19), we get:

$$(32) \quad \mathbb{E}[(\zeta_\delta^*)^2] = 2 \int_0^\infty h(1 - e^{-\delta c_\theta(h)}) dh = 2 \frac{\delta}{\beta} \int_0^\infty \frac{1}{2\beta\theta} \log\left(\frac{u + 2\theta\delta}{u}\right) (1 - e^{-u}) \frac{du}{u(u + 2\theta\delta)},$$

where we used the change of variable $u = \delta c_\theta(h)$. Let $a > 0$. We set:

$$g_{2,1}(a) = \int_1^\infty \log\left(\frac{u+a}{u}\right) (1 - e^{-u}) \frac{du}{u(u+a)}.$$

We have using that $0 \leq \log(1+x) \leq x$ for $x > 0$:

$$|g_{2,1}(a)| \leq a \int_1^\infty \frac{du}{u^3} \leq \frac{a}{2}.$$

We also have:

$$\begin{aligned} \int_0^1 \log\left(\frac{u+a}{u}\right) (1 - e^{-u}) \frac{du}{u(u+a)} &= \int_0^1 \log\left(\frac{u+a}{u}\right) \frac{du}{u+a} + g_{2,2}(a) \\ &= \int_0^\infty \frac{\log(v+1)}{v(v+1)} dv - g_{2,3}(a) + g_{2,2}(a), \end{aligned}$$

with the change of variable $v = a/u$ as well as:

$$g_{2,2}(a) = \int_0^1 \log\left(\frac{u+a}{u}\right) (1 - u - e^{-u}) \frac{du}{u(u+a)} \quad \text{and} \quad g_{2,3}(a) = \int_0^a \frac{\log(v+1)}{v(v+1)} dv.$$

We have, using $\log(1+v) \leq v$ for $v > 0$ (twice), that:

$$0 \leq g_{2,3}(a) \leq \int_0^a \frac{dv}{v+1} \leq a.$$

We have, using $|1 - u - e^{-u}| \leq u^2/2$ if $u > 0$ for the first inequality and (31) for the last, that:

$$|g_{2,2}(a)| \leq \frac{1}{2} \int_0^1 \log\left(1 + \frac{a}{u}\right) \frac{u du}{(u+a)} \leq \frac{a}{2} \int_0^1 \frac{du}{(u+a)} \leq a(|\log(a)| + \frac{1}{2}).$$

We deduce that:

$$\int_0^\infty \log\left(\frac{u+a}{u}\right) (1 - e^{-u}) \frac{du}{u(u+a)} = \int_0^\infty \frac{\log(v+1)}{v(v+1)} dv + g_2(a)$$

and

$$|g_2(a)| = |g_{2,1}(a) - g_{2,3}(a) + g_{2,2}(a)| \leq a(|\log(a)| + 2).$$

Then, use (32) as well as the identity (26) to get (28).

6.1.3. *Proof of (29).* Using properties of Poisson point measures, we get that if $\sum_{j \in J} \delta_{\zeta_j}$ is a Poisson point measure with intensity $\delta\mathbb{N}[d\zeta]$ and $\zeta_\delta^* = \max_{j \in J} \zeta_j$, then for any measurable non-negative functions f and g , we have:

$$\mathbb{E}\left[f(\zeta_\delta^*) e^{-\sum_{j \in J} g(\zeta_j)}\right] = \mathbb{E}\left[f(\zeta_\delta^*) e^{-g(\zeta_\delta^*) - G(\zeta_\delta^*)}\right] \quad \text{with} \quad G(r) = \delta\mathbb{N}\left[(1 - e^{-g(\zeta)}) \mathbf{1}_{\{\zeta < r\}}\right].$$

We deduce that:

$$\mathbb{E}\left[\zeta_\delta^* \sum_{i \in I} (\zeta_i - \varepsilon)_+\right] = \mathbb{E}[\zeta_\delta^* (\zeta_\delta^* - \varepsilon)_+] + \delta g_{3,1}(\delta),$$

with $g_{3,1}(\delta) = \mathbb{E} \left[\zeta_\delta^* \mathbb{N} [(\zeta - \varepsilon_+) \mathbf{1}_{\{\zeta < h\}}]_{|h=\zeta_\delta^*} \right]$. According to (27), there exists a finite constant $c > 0$ such that for all $\delta > 0$, we have $\mathbb{E}[\zeta_\delta^*] \leq c\delta(|\log(\delta)| + 1)(1 + \delta)$. We deduce from (21) that there exists a finite constant c independent of $\delta > 0$ and $\varepsilon \in (0, 1]$ such that:

$$g_{3,1}(\delta) \leq \mathbb{E}[\zeta_\delta^*] \mathbb{N}[(\zeta - \varepsilon)_+] \leq c\delta(|\log(\delta)| + 1)(1 + \delta)(|\log(\varepsilon)| + 1).$$

We also have:

$$\mathbb{E}[\zeta_\delta^* (\zeta_\delta^* - \varepsilon)_+] = \mathbb{E}[(\zeta_\delta^*)^2] - \mathbb{E}[(\zeta_\delta^*)^2 \mathbf{1}_{\{\zeta_\delta^* < \varepsilon\}}] - \varepsilon \mathbb{E}[\zeta_\delta^* \mathbf{1}_{\{\zeta_\delta^* > \varepsilon\}}] = 2\delta \int_0^\infty hc_\theta(h) dh + g_{3,2}(\varepsilon, \delta),$$

with, thanks to (27) and (28), $|g_{3,2}(\varepsilon, \delta)| \leq c\delta^2(|\log(\delta)| + 1) + \varepsilon^2 + c\varepsilon\delta(|\log(\delta)| + 1)(1 + \delta)$, for some finite constant c independent of $\delta > 0$ and $\varepsilon > 0$. We deduce that:

$$\mathbb{E} \left[\zeta_\delta^* \sum_{i \in I} (\zeta_i - \varepsilon)_+ \right] = 2\delta \int_0^\infty hc_\theta(h) dh + g_3(\delta)$$

and for some finite constant c independent of $\delta > 0$ and $\varepsilon \in (0, 1]$.

$$|g_3(\delta)| \leq c\delta^2(1 + \delta)(|\log(\delta)| + 1)(|\log(\varepsilon)| + 1) + c\varepsilon\delta(|\log(\delta)| + 1)(1 + \delta) + \varepsilon^2.$$

6.2. A technical lemma. An elementary induction gives for $n \in \mathbb{N}$ that:

$$\int_0^1 (1-x)^n |\log(x)| dx = \frac{H_{n+1}}{n+1} \quad \text{and} \quad \int_0^1 (1-x)^n \log^2(x) dx = \frac{2}{n+1} \sum_{k=1}^{n+1} \frac{H_k}{k},$$

where $H_n = \sum_{k=1}^n k^{-1}$ is the harmonic sum. Recall that $H_n = \log(n) + \gamma + (2n)^{-1} + O(n^{-2})$. So we deduce that:

$$(33) \quad (n+1) \int_0^1 (1-x)^n |\log(x)| dx = \log(n) + \gamma + \frac{3}{2n} + O(n^{-2}).$$

It is also easy to deduce that for $a, b \in \{1, 2\}$:

$$(34) \quad \int_0^1 x^a (1-x)^n |\log(x)|^b dx = O\left(\frac{\log^b(n)}{n^{a+1}}\right).$$

Recall $\tilde{\Lambda}_n$ and Δ_n defined in Section 6.1. We give a preliminary lemma.

Lemma 6.3. *We have:*

$$(35) \quad \mathbb{E}[\tilde{\Lambda}_n | \Delta_n] = \frac{Z_0}{\beta} (1 - \gamma) - \sum_{k=1}^n \frac{\Delta_{k,n}}{\beta} \log(2\theta \Delta_{k,n}) + W_n,$$

with $\mathbb{E}[|W_n| | Z_0] = O(n^{-1} \log(n))$ and

$$(36) \quad \mathbb{E}[\tilde{\Lambda}_n | Z_0] = \frac{Z_0}{\beta} \log\left(\frac{n}{2\theta Z_0}\right) + O(n^{-1} \log(n)).$$

We have also:

$$(37) \quad \mathbb{E}[\tilde{\Lambda}_n^2 | Z_0] = 2Z_0 \int_0^\infty hc_\theta(h) dh + \mathbb{E}[\tilde{\Lambda}_n | Z_0]^2 + O(n^{-1} \log^2(n)).$$

Proof. We first prove (35). We have $\mathbb{E}[\tilde{\Lambda}_n | \Delta_n] = \sum_{k=1}^n \mathbb{E}[\zeta_\delta^*]_{|\delta=\Delta_{k,n}}$. We deduce from (27) that (35) holds with:

$$W_n = \frac{\Delta_{0,n} + \Delta_{n+1,n}}{\beta} (\gamma - 1) + \frac{1}{\beta} \sum_{k=1}^n \Delta_{k,n} g_1(2\theta \Delta_{k,n}).$$

Since, conditionally on Z_0 , the random variables $\Delta_{k,n}$ are all distributed as $Z_0\tilde{U}_n$, where \tilde{U}_n is independent of Z_0 and has distribution $\beta(1, n+1)$, we deduce using (34) that:

$$\mathbb{E}[|W_n| | Z_0] \leq 2 \frac{(1-\gamma)Z_0}{\beta} \mathbb{E}[\tilde{U}_n] + n \frac{2\theta Z_0^2}{\beta} \mathbb{E}[\tilde{U}_n^2 (|\log(2\theta Z_0 \tilde{U}_n)| + 2) | Z_0] = O(n^{-1} \log(n)).$$

We then prove (36). Taking the expectation in (35) conditionally on Z_0 , we get:

$$\mathbb{E}[\tilde{\Lambda}_n | Z_0] = \frac{Z_0}{\beta} (1-\gamma) - n \frac{Z_0}{\beta} \mathcal{H}(2\theta Z_0) + \mathbb{E}[W_n | Z_0],$$

where

$$(38) \quad \mathcal{H}(a) = \mathbb{E}[\tilde{U}_n \log(a\tilde{U}_n)].$$

We deduce from (33) that:

$$(39) \quad n\mathcal{H}(a) = \log(a) - \log(n) + 1 - \gamma + O(n^{-1} \log(n)).$$

This gives:

$$\mathbb{E}[\tilde{\Lambda}_n | Z_0] = \frac{Z_0}{\beta} \log\left(\frac{n}{2\theta Z_0}\right) + O(n^{-1} \log(n)).$$

We finally prove (37). We have:

$$(40) \quad \mathbb{E}[\tilde{\Lambda}_n^2 | \Delta_n] = \sum_{k=1}^n \mathbb{E}[(\zeta_\delta^*)^2]_{|\delta=\Delta_{k,n}} - \sum_{k=1}^n \mathbb{E}[\zeta_\delta^{*1}]_{|\delta=\Delta_{k,n}}^2 + \mathbb{E}[\tilde{\Lambda}_n | \Delta_n]^2.$$

We have thanks to (28):

$$\sum_{k=1}^n \mathbb{E}[(\zeta_\delta^*)^2]_{|\delta=\Delta_{k,n}} = 2Z_0 \int_0^\infty hc_\theta(h) dh + W_{1,n},$$

with

$$W_{1,n} = -2(\Delta_{0,n} + \Delta_{n+1,n}) \int_0^\infty hc_\theta(h) dh + \sum_{k=1}^n \frac{\Delta_{k,n}}{\beta^2 \theta} g_2(2\theta \Delta_{k,n}).$$

Using similar computations as the ones used to bound $\mathbb{E}[|W_n| | Z_0]$, we get $\mathbb{E}[|W_{1,n}| | Z_0] = O(n^{-1} \log(n))$ so that

$$\mathbb{E}\left[\sum_{k=1}^n \mathbb{E}[(\zeta_\delta^*)^2]_{|\delta=\Delta_{k,n}} \mid Z_0\right] = 2Z_0 \int_0^\infty hc_\theta(h) dh + O(n^{-1} \log(n)).$$

Thanks to (27), we have $\mathbb{E}[\zeta_\delta^*]^2 \leq c\delta^2 (|\log(\delta)| + 1)^2 (1 + \delta)^2$ for some finite constant c which does not depend on δ . We set $\mathcal{H}_2(a) = \mathbb{E}[\tilde{U}_n^2 \log^2(a\tilde{U}_n)(1 + \tilde{U}_n)^2]$, and using (34), we get:

$$(41) \quad \mathcal{H}_2(a) = O(n^{-3} \log^2(n)) = O(n^{-2} \log^2(n)).$$

We deduce that:

$$\mathbb{E}\left[\sum_{k=1}^n \mathbb{E}[\zeta_\delta^{*1}]_{|\delta=\Delta_{k,n}}^2 \mid Z_0\right] = O(n^{-1} \log^2(n)).$$

Then using (36), elementary computations give:

$$\mathbb{E}\left[\mathbb{E}[\tilde{\Lambda}_n | \Delta_n]^2 \mid Z_0\right] = 2 \frac{Z_0}{\beta} (1-\gamma) \mathbb{E}[\tilde{\Lambda}_n | Z_0] - \frac{Z_0^2}{\beta^2} (1-\gamma)^2 + \frac{1}{\beta^2} J_{1,n} + J_{2,n} - \frac{2}{\beta} J_{3,n},$$

with $J_{2,n} = \mathbb{E}[W_n^2 | Z_0]$,

$$J_{1,n} = \mathbb{E} \left[\left(\sum_{k=1}^n \Delta_{k,n} \log(2\theta \Delta_{k,n}) \right)^2 \middle| Z_0 \right] \quad \text{and} \quad J_{3,n} = \mathbb{E} \left[W_n \left(\sum_{k=1}^n \Delta_{k,n} \log(2\theta \Delta_{k,n}) \right) \middle| Z_0 \right].$$

By Cauchy-Schwartz, we have $|J_{3,n}| \leq \sqrt{J_{1,n} J_{2,n}}$. Using $(\sum_{k=1}^n a_k)^2 \leq n \sum_{k=1}^n a_k^2$, we also get:

$$J_{2,n} \leq \frac{8}{\beta^2} (\gamma - 1)^2 Z_0^2 \mathbb{E}[\tilde{U}_n^2] + \frac{2n}{\beta^2} Z_0^2 \mathbb{E} \left[\tilde{U}_n^2 g_1^2(2\theta Z_0 \tilde{U}_n) \right] = O(n^{-2}).$$

By independence, we obtain:

$$J_{1,n} = n(n-1) \mathbb{E}[\Delta_{1,n} \log(2\theta \Delta_{1,n}) | Z_0]^2 + n \mathbb{E}[\Delta_{1,n}^2 \log^2(2\theta \Delta_{1,n}) | Z_0].$$

Recall the function \mathcal{H} defined in (38) and its asymptotic expansion (39). We have, using (41), that:

$$J_{1,n} = n(n-1) Z_0^2 \mathcal{H}(2\theta Z_0)^2 + n Z_0^2 \mathcal{H}_2(2Z_0) = Z_0^2 \left(-\log \left(\frac{n}{2\theta Z_0} \right) + 1 - \gamma \right)^2 + O(n^{-1} \log^2(n)).$$

So we deduce that:

$$\begin{aligned} \frac{1}{\beta^2} J_{1,n} + J_{2,n} - \frac{2}{\beta} J_{3,n} &= \left(-\frac{Z_0}{\beta} \log \left(\frac{n}{2\theta Z_0} \right) + \frac{Z_0}{\beta} (1 - \gamma) \right)^2 + O(n^{-1} \log^2(n)) \\ &= \left(-\mathbb{E}[\tilde{\Lambda}_n | Z_0] + \frac{Z_0}{\beta} (1 - \gamma) \right)^2 + O(n^{-1} \log^2(n)). \end{aligned}$$

We deduce that:

$$\mathbb{E} \left[\mathbb{E} \left[\tilde{\Lambda}_n | \Delta_n \right]^2 \middle| Z_0 \right] = \mathbb{E}[\tilde{\Lambda}_n | Z_0]^2 + O(n^{-1} \log^2(n)).$$

So in the end, using (40), we get:

$$\mathbb{E} \left[\tilde{\Lambda}_n^2 | Z_0 \right] = 2Z_0 \int_0^\infty hc_\theta(h) dh + \mathbb{E}[\tilde{\Lambda}_n | Z_0]^2 + O(n^{-1} \log^2(n)).$$

□

6.3. Proof of Proposition 3.13. We set $J_n(\varepsilon) = \mathbb{E} \left[\left(\tilde{\Lambda}_n - \tilde{L}_\varepsilon \right)^2 \middle| Z_0 \right]$. We have:

$$J_n(\varepsilon) = \mathbb{E}[\tilde{\Lambda}_n^2 | Z_0] + \mathbb{E}[\tilde{L}_\varepsilon^2 | Z_0] - 2\mathbb{E}[\tilde{\Lambda}_n \tilde{L}_\varepsilon | Z_0].$$

By conditioning with respect to Δ_n , and using the independence, we get:

$$\mathbb{E}[\tilde{\Lambda}_n \tilde{L}_\varepsilon | Z_0] = \mathbb{E} \left[\mathbb{E}[\tilde{\Lambda}_n \tilde{L}_\varepsilon | \Delta_n] \middle| Z_0 \right] = \Sigma_n + \mathbb{E} \left[\mathbb{E}[\tilde{\Lambda}_n | \Delta_n] \mathbb{E}[\tilde{L}_\varepsilon | \Delta_n] \middle| Z_0 \right] = \Sigma_n + \mathbb{E}[\tilde{\Lambda}_n | Z_0] \mathbb{E}[\tilde{L}_\varepsilon | Z_0],$$

where we used that $\mathbb{E}[\tilde{L}_\varepsilon | \Delta_n] = \mathbb{E}[\tilde{L}_\varepsilon | Z_0]$ for the last equality, and:

$$\Sigma_n = \mathbb{E} \left[\sum_{k=1}^n \mathbb{E} \left[\zeta_{k,n}^* \sum_{z_i \in I_{k,n}} (\zeta_i - \varepsilon)_+ \middle| \Delta_n \right] - \sum_{k=1}^n \mathbb{E}[\zeta_{k,n}^* | \Delta_n] \mathbb{E} \left[\sum_{z_i \in I_{k,n}} (\zeta_i - \varepsilon)_+ \middle| \Delta_n \right] \middle| Z_0 \right].$$

So using (24) and (37), we get:

$$J_n(\varepsilon) = 4Z_0 \int_0^\infty hc_\theta(h) dh - 2\Sigma_n + \left(\mathbb{E}[\tilde{\Lambda}_n | Z_0] - \mathbb{E}[\tilde{L}_\varepsilon | Z_0] \right)^2 + O(\varepsilon \log(\varepsilon)) + O(n^{-1} \log^2(n)).$$

Then taking $\varepsilon \asymp n^{-1}$, we get, using (23), (36) and Lemma 6.4 below:

$$J_n(\varepsilon) = \frac{Z_0^2}{\beta^2} \log^2 \left(n\varepsilon \frac{\beta}{Z_0} \right) + O(n^{-1} \log^2(n)).$$

We deduce that $\tilde{\Lambda}_n - \tilde{L}_{Z_0/(n\beta)}$ converges in probability to 0 and, by Borel-Cantelli lemma almost surely along the sub-sequence n^3 . Recall that the sequence $(\tilde{L}_\varepsilon - \mathbb{E}[\tilde{L}_\varepsilon | Z_0], \varepsilon > 0)$ converges a.s., as ε goes down to 0, towards a limit say $\tilde{\mathcal{L}}$. Notice that $\mathbb{E}[\tilde{L}_{Z_0/n\beta} | Z_0] = \mathbb{E}[\tilde{\Lambda}_n | Z_0] + O(n^{-1} \log(n))$ and thus, we deduce that $(\tilde{\Lambda}_{n^3} - \mathbb{E}[\tilde{\Lambda}_{n^3} | Z_0], n \in \mathbb{N}^*)$ converges also a.s. towards $\tilde{\mathcal{L}}$. Then use (35) to get that for $k \in [n^3, (n+1)^3]$:

$$\tilde{\Lambda}_{n^3} - \mathbb{E}[\tilde{\Lambda}_{n^3} | Z_0] + O(n^{-1} \log(n)) \leq \tilde{\Lambda}_k - \mathbb{E}[\tilde{\Lambda}_k | Z_0] \leq \tilde{\Lambda}_{(n+1)^3} - \mathbb{E}[\tilde{\Lambda}_{(n+1)^3} | Z_0] + O(n^{-1} \log(n)).$$

Then conclude that $(\tilde{\Lambda}_n - \mathbb{E}[\tilde{\Lambda}_n | Z_0], n \in \mathbb{N}^*)$ converges also a.s. towards \mathcal{L} .

Lemma 6.4. *Let $\varepsilon \asymp n^{-1}$. We have:*

$$\Sigma_n = 2Z_0 \int_0^\infty hc_\theta(h) dh + O(n^{-1} \log^2(n)).$$

Proof. We have $\mathbb{E} \left[\sum_{z_i \in I_{k,n}} (\zeta_i - \varepsilon)_+ \mid \Delta_n \right] = \Delta_{k,n} \mathbb{N}[(\zeta - \varepsilon)_+]$. Thanks to (27), (33) and (34), we get:

$$\begin{aligned} \mathbb{E} \left[\sum_{k=1}^n \Delta_{k,n} \mathbb{E}[\zeta_{k,n}^* | \Delta_n] \mid Z_0 \right] &= \frac{nZ_0^2}{\beta} \mathbb{E} \left[\tilde{U}_n^2 \left(\log(2\theta Z_0 \tilde{U}_n) + (1 - \gamma) + g_1(2\theta Z_0 \tilde{U}_n) \right) \mid Z_0 \right] \\ &= O(n^{-2} \log(n)). \end{aligned}$$

We deduce from (21) with $\varepsilon \asymp n^{-1}$ that:

$$\mathbb{E} \left[\sum_{k=1}^n \mathbb{E}[\zeta_{k,n}^* | \Delta_n] \mathbb{E} \left[\sum_{z_i \in I_{k,n}} (\zeta_i - \varepsilon)_+ \mid \Delta_n \right] \mid Z_0 \right] = O(n^{-1} \log^2(n)).$$

According to (29), we have:

$$\sum_{k=1}^n \mathbb{E} \left[\zeta_{k,n}^* \sum_{z_i \in I_{k,n}} (\zeta_i - \varepsilon)_+ \mid \Delta_n \right] = 2Z_0 \int_0^\infty hc_\theta(h) dh + W_n''',$$

with

$$W_n''' = -2(\Delta_{0,n} + \Delta_{n+1,n}) \int_0^\infty hc_\theta(h) dh + \sum_{k=1}^n g_3(\Delta_{k,n}).$$

Since $\varepsilon \asymp n^{-1}$, we deduce that

$$\mathbb{E}[|W_n'''| | Z_0] \leq \frac{2Z_0}{n+1} \int_0^\infty hc_\theta(h) dh + O(n^{-1} \log^2(n)).$$

This gives the result. \square

REFERENCES

- [1] R. Abraham and J.-F. Delmas. Williams' decomposition of the Lévy continuum random tree and simultaneous extinction probability for populations with neutral mutations. *Stochastic Process. Appl.*, 119(4):1124–1143, 2009.
- [2] R. Abraham, J.-F. Delmas, and P. Hoscheit. A note on the Gromov-Hausdorff-Prokhorov distance between (locally) compact metric measure spaces. *Electron. J. Probab.*, 18:no. 14, 21, 2013.
- [3] D. Aldous. The continuum random tree. I. *Ann. Probab.*, 19(1):1–28, 1991.
- [4] D. Aldous and L. Popovic. A critical branching process model for biodiversity. *Adv. in Appl. Probab.*, 37(4):1094–1115, 12 2005.
- [5] H. Bi and J.-F. Delmas. Total length of the genealogical tree for quadratic stationary continuous-state branching processes. *Ann. Inst. Henri Poincaré Probab. Stat.*, 52(3):1321–1350, 2016.
- [6] A. N. Borodin and P. Salminen. *Handbook of Brownian motion—facts and formulae*. Probability and its Applications. Birkhäuser Verlag, Basel, second edition, 2002.
- [7] D. Burago, Y. D. Burago, and S. Ivanov. *A course in metric geometry*. American Mathematical Society, Providence, 2001.
- [8] Y.-T. Chen and J.-F. Delmas. Smaller population size at the MRCA time for stationary branching processes. *The Annals of Probability*, 40(5):2034–2068, 2012.
- [9] M. Dávila Felipe and A. Lambert. Time reversal dualities for some random forests. *ALEA Lat. Am. J. Probab. Math. Stat.*, 12(1):399–426, 2015.
- [10] A. Dress, V. Moulton, and W. Terhalle. *T-theory: an overview*. *European J. Combin.*, 17(2-3):161–175, 1996. Discrete metric spaces (Bielefeld, 1994).
- [11] T. Duquesne. The coding of compact real trees by real valued functions. arXiv:math/0604106, 2006.
- [12] T. Duquesne and J.-F. Le Gall. Random trees, Lévy processes and spatial branching processes. *Astérisque*, (281):vi+147, 2002.
- [13] T. Duquesne and J.-F. Le Gall. Probabilistic and fractal aspects of Lévy trees. *Probab. Theory Related Fields*, 131(4):553–603, 2005.
- [14] S. N. Evans. *Probability and real trees*, volume 1920 of *Lecture Notes in Mathematics*. Springer, Berlin, 2008. Lectures from the 35th Summer School on Probability Theory held in Saint-Flour, July 6–23, 2005.
- [15] S. N. Evans, J. Pitman, and A. Winter. Rayleigh processes, real trees, and root growth with re-grafting. *Probab. Theory Related Fields*, 134(1):81–126, 2006.
- [16] M. Gromov. *Metric structures for Riemannian and non-Riemannian spaces*, volume 152 of *Progress in Mathematics*. Birkhäuser Boston, Inc., Boston, MA, 1999. Based on the 1981 French original [MR0682063 (85e:53051)], With appendices by M. Katz, P. Pansu and S. Semmes, Translated from the French by Sean Michael Bates.
- [17] A. Lambert. Coalescence times for the branching process. *Advances in Applied Probability*, 35(4):1071–1089, 2003.
- [18] A. Lambert. Quasi-stationary distributions and the continuous-state branching process conditioned to be never extinct. *Electron. J. Probab.*, 12:no. 14, 420–446, 2007.
- [19] J.-F. Le Gall and Y. Le Jan. Branching processes in Lévy processes: the exploration process. *Ann. Probab.*, 26(1):213–252, 1998.
- [20] J. Neveu and J. Pitman. Renewal property of the extrema and tree property of the excursion of a one-dimensional Brownian motion. In *Séminaire de Probabilités, XXIII*, volume 1372 of *Lecture Notes in Math.*, pages 239–247. Springer, Berlin, 1989.
- [21] J. Neveu and J. W. Pitman. The branching process in a Brownian excursion. In *Séminaire de Probabilités, XXIII*, volume 1372 of *Lecture Notes in Math.*, pages 248–257. Springer, Berlin, 1989.
- [22] P. Pfaffelhuber, A. Wakolbinger, and H. Weisshaupt. The tree length of an evolving coalescent. *Probab. Theory Related Fields*, 151(3-4):529–557, 2011.
- [23] L. Popovic. Asymptotic genealogy of a critical branching process. *Ann. Appl. Probab.*, 14(4):2120–2148, 2004.
- [24] S. Roelly-Coppoletta and A. Rouault. Processus de Dawson-Watanabe conditionné par le futur lointain. *C. R. Acad. Sci. Paris Sér. I Math.*, 309(14):867–872, 1989.

ROMAIN ABRAHAM, LABORATOIRE MAPMO, CNRS, UMR 7349, FÉDÉRATION DENIS POISSON, FR 2964,
UNIVERSITÉ D'ORLÉANS, B.P. 6759, 45067 ORLÉANS CEDEX 2, FRANCE

E-mail address: `romain.abraham@univ-orleans.fr`

JEAN-FRANÇOIS DELMAS, UNIVERSITÉ PARIS-EST, CERMICS (ENPC), F-77455, FRANCE

E-mail address: `delmas@cermics.enpc.fr`