



HAL
open science

Real time Autopilot based on Immersion & Invariance for Autonomous Aerial Vehicle

Yasser Bouzid, Houria Siguerdidjane, Yasmina Bestaoui

► **To cite this version:**

Yasser Bouzid, Houria Siguerdidjane, Yasmina Bestaoui. Real time Autopilot based on Immersion & Invariance for Autonomous Aerial Vehicle. IFAC Symposium on Automatic Control in Aerospace, Aug 2016, Sherbrooke, Canada. 10.1016/j.ifacol.2016.09.031 . hal-01412022

HAL Id: hal-01412022

<https://hal.science/hal-01412022>

Submitted on 27 Mar 2020

HAL is a multi-disciplinary open access archive for the deposit and dissemination of scientific research documents, whether they are published or not. The documents may come from teaching and research institutions in France or abroad, or from public or private research centers.

L'archive ouverte pluridisciplinaire **HAL**, est destinée au dépôt et à la diffusion de documents scientifiques de niveau recherche, publiés ou non, émanant des établissements d'enseignement et de recherche français ou étrangers, des laboratoires publics ou privés.

Real time Autopilot based on Immersion & Invariance for Autonomous Aerial Vehicle

Y. Bouzid*, H. Siguerdidjane**, Y. Bestaoui*

* *IBISC, Université d'Evry-Val-d'Essonne, Université Paris-Saclay, Evry, France*
(e-mail : Yasser.Bouzid@ufrst.univ-evry.fr, yasmina.bestoui@ufrst.univ-evry.fr)

***L2S, CentraleSupélec, Université Paris-Saclay, Gif-sur-yvette, France*
(e-mail : Houria.Siguerdidjane@centralesupelec.fr)

Abstract: UAV's will play a significant role in some future ground operations. Therefore, the exploration of the applicability level of advanced control laws or new developments and the resulting performance is of a great interest. Thus, this paper deals with the application of Immersion and Invariance (I&I) based approach to control a Quad-Rotor. This control manages the longitudinal and lateral motions. The main objective is in the one hand to maintain the vehicle stable throughout the whole generated trajectory that may be composed of different type line segments or arcs, with and without disturbances and in the other hand, to ensure an adequate behavior of the vehicle when passing through defined way-points. The system is modeled via Euler-Newton formalism and the control architecture is arranged in two levels. The first one executes a control law for altitude and yaw motions derived by using a feedback linearization technique. The second level concerns the movement in the XY-plan using I&I approach. A series of experimental tests are performed on a vehicle available in our laboratory for which one demonstrates the effectiveness of the proposed control strategy.

Keywords: Nonlinear control, Autonomous system, Trajectory tracking.

1. INTRODUCTION

Quad-Rotors are now being the more popular Multi-Rotors rotorcrafts. They are considered as an ideal tool for many missions such as surveillance, rescue and a variety of innovative potential applications in the near future. This is due to their mechanical structure, small size, low weight and high maneuverability.

The Quad-Rotor control field has attracted numerous researchers and engineers who have applied various methods for the flight control and stabilization. Among them, one may find for example backstepping control (Frazzoli et al. 2000), integral backstepping control (Bouabdallah et al. 2007), dynamic inversion (Das et al. 2008), adaptive control (Bouadi et al. 2011), predictive control (Alexis et al. 2011), optimal control (Satici et al. 2013) and LQ and H_∞ (Araar et al. 2014).

The Quad-Rotor is a nonlinear, unstable and underactuated system. In order to tackle such problems and to improve the system performance, this work addresses a controller based on a nonlinear approach as the use of such controllers in an efficient way is still under current investigations, due to the increasing number of flight configurations. Up to now, the techniques described in the literature do not include the application of I&I approach to evaluate the performance and the design of UAV's autopilot, at least to our knowledge, even though it has been employed as nonlinear estimator based on the notion of invariant manifolds or to design global asymptotic stability of observers for unmeasured states (Zhang et al., 2011; Hu et al. 2013; Zhao et al. 2014).

Then, in this paper, we focus on the design of Immersion and Invariance (I&I) control technique synthesized for longitudinal and lateral motions, investigating its level of applicability. The separation of Lateral-Longitudinal motions is considered because it is usually simpler. Our objective is to design a nonlinear flight controller that performs quite well in practice and ensures the asymptotic stability of the closed-loop system. By exploiting this structural property, the standard model of Quad-Rotor may be transformed into two subsystems where each one is controlled individually. The effectiveness of the main control is validated using first of all a Virtual Robotics Experimental Platform (Gazebo) and then an available Quad-Rotor on Robotics Operating System (ROS) (see Fig. 1).

I&I approach is a control tool based on two classical theories, which are system Immersion and manifold Invariance. In fact, this control technique is used for stability analysis of nonlinear systems and for designing adaptive control of specific classes of systems (Acosta et al. 2008). The main advantage of the I&I approach is to make the closed loop system behavior like a target system with specified properties. Even in presence of disturbances, the control solution should maintain the vehicle stable along the whole trajectory.

The outline of this work is structured in the following way: Section 2 describes the dynamics of the vehicle. Section 3 derives the nonlinear control strategy in the field of UAVs for XY-plan navigation. In section 4, experimental tests are shown and emphasized the effectiveness of the proposed

controller under different operating conditions. The final section discusses the obtained results.

2. VEHICLE DYNAMICS BACKGROUND

The Quad-Rotor (Fig. 1) has four rotors with twin-bladed propellers and equipped with two boards. The first comprises two cameras, microcontroller ARM Cortex-A8 and Wi-Fi module. The second board concerns the navigation module, which contains the necessary sensors. The Inertial Measurement Unit (IMU) consists of 3-axis gyroscope and 3-axis accelerometer. A barometric sensor and an ultrasonic sensor measure the altitude.

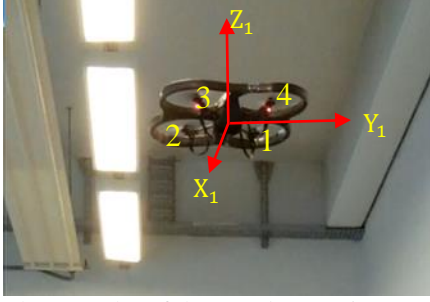

Fig. 1. Photography of the Quad-Rotor in experimentation.

As shown in Fig. 2, the system operates in two coordinate frames: the earth fixed frame $R_0(O_0, X, Y, Z)$ and the body frame $R_1(O_1, X_1, Y_1, Z_1)$. Let $\eta = (\varphi, \theta, \Psi)^T \in \left[-\frac{\pi}{2}, +\frac{\pi}{2}\right] \times \left[-\frac{\pi}{2}, +\frac{\pi}{2}\right] \times [-\pi, +\pi[$ describes the orientation of the aerial vehicle (Roll, Pitch, Yaw) and $\chi = (x, y, z)^T \in \mathbb{R}^3$ denotes its absolute position.

The dynamics of the Quad-Rotor were derived taking into account the work presented in (Hamel et al. 2002). The following assumptions were made:

- (A1) The structure and the propellers are rigid and symmetric (with a suitable choice of the body reference frame as depicted in Fig. 1, the inertia matrix is diagonal).
- (A2) The gyroscopic and ground effects are neglected.

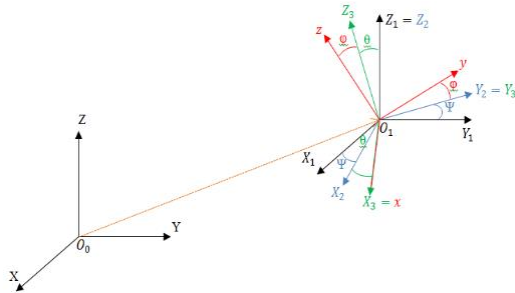

Fig. 2. Frames representation.

Gravity force, expressed in the earth fixed frame in the negative Z direction, acts on the center of mass of the vehicle. The total thrust is in the positive Z direction and expressed in the body fixed frame. Then, it must be rotated into the earth fixed frame. Therefore, the translational dynamic may be expressed as follows

$$m\ddot{\chi} = -mge_z + u_1 R e_z \quad (1)$$

Where m denotes the mass, g the gravity acceleration, $e_z = (0,0,1)^T$ the unit vector of Z-axis and u_1 the total thrust of four rotors, which have speeds Ω_i , that is:

$$u_1 = \sum_{i=1}^4 T_i = b \sum_{i=1}^4 \Omega_i^2 \quad (2)$$

where b is the thrust factor.

The rotation matrix R is given by

$$R(\varphi, \theta, \Psi) = \begin{bmatrix} c_\psi c_\theta & c_\psi s_\theta s_\varphi - s_\psi c_\varphi & c_\psi s_\theta c_\varphi + s_\psi s_\varphi \\ s_\psi c_\theta & s_\psi s_\theta s_\varphi + c_\psi c_\varphi & s_\psi s_\theta c_\varphi - c_\psi s_\varphi \\ -s_\theta & c_\theta s_\varphi & c_\theta c_\varphi \end{bmatrix}$$

Where $s_{(\cdot)}$ and $c_{(\cdot)}$ are abbreviations for $\sin(\cdot)$ and $\cos(\cdot)$ respectively.

Pitch and roll movements, are created by the difference in combined thrust in the opposite sides of the vehicle. However, yaw movement is generated by the differential drag forces D_i .

$$D_i = d\Omega_i^2 \quad i = 1, \dots, 4 \quad (3)$$

where d is the drag factor.

The rotational dynamic equation can be written as follows

$$I\dot{\omega} = -\omega \times I\omega - G_a + \tau \quad (4)$$

Where $\omega = (\omega_x, \omega_y, \omega_z)^T$ denotes the angular velocity vector, $I = \text{diag}(I_x, I_y, I_z)$ is the diagonal inertia matrix and $\tau = (u_2, u_3, u_4)^T$ is the control torque

$$\begin{pmatrix} u_2 \\ u_3 \\ u_4 \end{pmatrix} = \begin{pmatrix} l(T_1 + T_4 - T_2 - T_3) \\ l(T_3 + T_4 - T_1 - T_2) \\ (D_1 + D_3) - (D_2 + D_4) \end{pmatrix}$$

l represents the length from the center of mass to the motor. The gyroscopic effects G_a are neglected under assumption (A2) considered above. Then,

$$\dot{\omega} = I^{-1}(-\omega \times I\omega + \tau) \quad (5)$$

The angular velocity ω of the Quad-Rotor is transformed into Euler angular speeds $\dot{\eta}$. This yields

$$\dot{\eta} = \begin{bmatrix} 1 & s_\varphi \tan \theta & c_\varphi \tan \theta \\ 0 & c_\varphi & -s_\varphi \\ 0 & s_\varphi / c_\theta & c_\varphi / c_\theta \end{bmatrix} \omega \quad (6)$$

In conditions of flying at low indoor speed or hovering and by using equations (1) and (5-6), the simplified dynamic model of the vehicle may be written as:

$$\ddot{\chi} = \begin{pmatrix} u_1 \frac{c_\psi s_\theta c_\varphi + s_\psi s_\varphi}{m} \\ u_1 \frac{s_\psi s_\theta c_\varphi - c_\psi s_\varphi}{m} \\ -g + u_1 \frac{c_\theta c_\varphi}{m} \end{pmatrix} \quad (7)$$

$$\dot{\eta} = \begin{pmatrix} \dot{\theta} \dot{\Psi} \left(\frac{I_y - I_z}{I_x} \right) + \frac{u_2}{I_x} \\ \dot{\varphi} \dot{\Psi} \left(\frac{I_z - I_x}{I_y} \right) + \frac{u_3}{I_y} \\ \dot{\varphi} \dot{\theta} \left(\frac{I_x - I_y}{I_z} \right) + \frac{u_4}{I_z} \end{pmatrix} \quad (8)$$

Consequently, a Quad-Rotor is an under-actuated system with four control inputs (u_1, u_2, u_3, u_4) and six outputs $(x, y, z, \varphi, \theta, \Psi)$.

3. NON LINEAR CONTROLLER DESIGN

The controller is herein designed to ensure the tracking of the desired trajectory along the three axes (X, Y, Z) and the yaw angle. The controller is based on the decomposition into lateral and longitudinal motions via u_2 and u_3 . The altitude is controlled by u_1 and the yaw angle is controlled by u_4 . The control structure is shown in Fig. 3.

3.1. Review of I&I based approach

The use of this approach (I&I) for stabilization of nonlinear systems was originated in (Astolfi & Ortega 2003). First, we briefly recall in the following section the definitions of the concepts of invariant manifold and immersion of systems.

Definition 1: Consider the following autonomous system $\dot{x} = f(x)$, $y = h(x)$, with $x \in R^n$ and $y \in R^m$ (9) The manifold $\mathcal{M} = \{x \in R^n | \varphi(x) = 0\}$, is said to be invariant for $\dot{x} = f(x)$ if: $\varphi(x(0)) = 0 \Rightarrow \varphi(x(t))_{t \geq 0} = 0$ where $\varphi(x)$ is a smooth flow.

Definition 2: Immersion is a mapping of the initial state to another state-space of higher dimension. Consider, the following system

$$\dot{\xi} = \alpha(\xi), \zeta = \beta(\xi) \text{ with } \xi \in R^p \text{ and } \zeta \in R^m \quad (10)$$

System (10) is said to be immersed into system (9) if there exists a smooth mapping $\pi: R^p \rightarrow R^n$ which satisfies

$$\begin{aligned} - x(0) &= \pi(\xi(0)) \\ - \beta(\xi_1) &\neq \beta(\xi_2) \Rightarrow h(\pi(\xi_1)) \neq h(\pi(\xi_2)) \end{aligned}$$

and such that

$$f(\pi(\xi)) = \frac{\partial \pi}{\partial \xi} \alpha(\xi) \text{ and } h(\pi(\xi)) = \beta(\xi) \text{ for all } \xi \in R^p$$

The major result of Immersion and Invariance is introduced by the following theorem:

Theorem 1: Consider the system

$$\dot{x} = f(x) + g(x)u \quad (11)$$

With a state vector $x \in R^n$, input $u \in R^m$ and $x^* \in R^n$ an equilibrium point to be stabilized.

Let $p < n$ and assuming existence of smooth mappings

$$\begin{aligned} \alpha: R^p &\rightarrow R^p, \pi: R^p \rightarrow R^n, \zeta: R^n \rightarrow R^m \\ \phi: R^n &\rightarrow R^{n-p}, \psi: R^{n \times (n-p)} \rightarrow R^m \end{aligned}$$

such that the following hold.

- (C1) *Target system*

The system $\dot{\xi} = \alpha(\xi)$ with state $\xi \in R^p$, has an asymptotically stable equilibrium at $\xi^* \in R^p$ and $x^* = \pi(\xi^*)$

- (C2) *Immersion condition*

$$\text{For all } \xi \in R^p, f(\pi(\xi)) + g(\pi(\xi))\zeta(\pi(\xi)) = \frac{\partial \pi}{\partial \xi} \alpha(\xi)$$

- (C3) *Implicit manifold*

The set identity $\{x \in R^n | \phi(x) = 0\} =$

$$\{x \in R^n | x = \pi(\xi) \text{ for some } \xi \in R^p\} \text{ holds}$$

- (C4) *Manifold attractively and trajectory boundedness*

All trajectories of the system

$$\dot{z} = \frac{\partial \phi}{\partial x} (f(x) + g(x)\psi(x, z))$$

$$\dot{x} = f(x) + g(x)\psi(x, z)$$

where $z = \phi(x)$, are bounded and satisfy $\lim_{t \rightarrow \infty} z(t) = 0$.

Then, x^* is asymptotically stable equilibrium of the closed loop system $\dot{x} = f(x) + g(x)\psi(x, \phi(x))$ (For the theorem proof, see (Astolfi et al. 2003)).

3.2. Altitude and yaw control

Let us first start with the control of altitude and yaw quantities. The control of the vertical position and the yaw motion can be obtained by using the feedback linearization control:

$$u_1 = \frac{m}{c_\theta c_\varphi} (v_z + g + \dot{z}_r) \quad (12)$$

$$u_4 = I_z \left(v_\psi - \phi \dot{\theta} \left(\frac{I_x - I_y}{I_z} \right) + \ddot{\Psi}_r \right) \quad (13)$$

With

$$v_z = k_{p,z}(z_r - z) + k_{d,z}(\dot{z}_r - \dot{z})$$

$$v_\psi = -k_{p,\psi}(\Psi_r - \Psi) + k_{d,\psi}(\dot{\Psi}_r - \dot{\Psi})$$

Where the parameters $k_{p,z}, k_{d,z}, k_{p,\psi}$ and $k_{d,\psi}$ are positive constants that should be chosen to ensure well damped time response and to also ensure that the control signals are within the actuator limits. z_r and Ψ_r define the reference trajectories.

3.3. Lateral and longitudinal control

Now, we apply the I&I method to translational subsystem (7) which must be transformed into an appropriate form. Indeed, substituting equations (12) into (7), we obtain

$$\begin{cases} \ddot{x} = (v_z + g + \dot{z}_r) \left(c_\psi \tan(\theta) + \frac{s_\psi}{c_\theta} \tan(\varphi) \right) \\ \ddot{y} = (v_z + g + \dot{z}_r) \left(s_\psi \tan(\theta) - \frac{c_\psi}{c_\theta} \tan(\varphi) \right) \end{cases} \quad (14)$$

To simplify and adapting model (14) to the control approach, we make the following assumptions:

Assumption (A3): The entire reference trajectories $(\cdot)_r$ allowed for this study are considered piecewise constant.

Assumption (A4): For a large enough time duration, then $v_z \rightarrow 0$, indeed we consider v_z arbitrarily small and z close to z_r .

Assumption (A5): The Quad-Rotor has very small upper bounds on $|\varphi|$ and $|\theta|$ so that, the differences $\varphi - \tan(\varphi)$ and $\theta - \tan(\theta)$ are arbitrarily small.

Therefore, system (14) is reduced to

$$\begin{cases} \ddot{x} = g(\theta c_\psi + \varphi s_\psi) \\ \ddot{y} = g(\theta s_\psi - \varphi c_\psi) \end{cases} \quad (15)$$

This system is then equivalent to

$$\begin{pmatrix} \ddot{x} \\ \ddot{y} \end{pmatrix} = \mathcal{R} \begin{pmatrix} \theta \\ \varphi \end{pmatrix} \quad (16)$$

Where $\mathcal{R} = g \begin{pmatrix} c_\psi & s_\psi \\ s_\psi & -c_\psi \end{pmatrix}$, is a dynamic, invertible and symmetric matrix.

Setting that $\begin{pmatrix} \ddot{x} \\ \ddot{y} \end{pmatrix} = \mathcal{R}^{-1} \begin{pmatrix} \ddot{x} \\ \ddot{y} \end{pmatrix}$, a simplified system is thus

$$\begin{pmatrix} \ddot{x} \\ \ddot{y} \end{pmatrix} = \begin{pmatrix} \theta \\ \varphi \end{pmatrix} \quad (17)$$

System (8) can be simplified using a change of inputs variables

$$\tau = I\bar{\tau} + \dot{\eta} \times I\dot{\eta} \quad (18)$$

Where $\bar{\tau} = (\bar{u}_2, \bar{u}_3, \bar{u}_4)^T$

Using equations (8), (17) and (18), the following lateral and longitudinal systems are obtained

$$\begin{cases} \ddot{x} = \theta \\ \ddot{\theta} = \bar{u}_3 \end{cases} \quad (19)$$

and

$$\begin{cases} \ddot{y} = \varphi \\ \ddot{\varphi} = \bar{u}_2 \end{cases} \quad (20)$$

Notice that these two systems have exactly the same form. By choosing a state vector as $x = (x_1, x_2, x_3, x_4)^T = (x_r - \bar{x}, \dot{x}, \theta, \dot{\theta})^T$, we finally get

$$\begin{cases} \dot{x}_1 = -x_2 \\ \dot{x}_2 = x_3 \\ \dot{x}_3 = x_4 \\ \dot{x}_4 = \bar{u}_3 \end{cases} \quad (21)$$

Where $x_1 = x_r - \bar{x}$ is the tracking error between the reference trajectory x_r and \bar{x} .

Using I&I approach, system (21) is then stabilized. For this end, we apply *theorem 1*. I&I technique requires the selection of a target dynamical system. In order to avoid solving the partial differential equation (C2), it has been proposed to choose the target system as a mechanical one parameterized in terms of potential and damping functions (see Acosta *et al.* 2008). Thus, we define the target system as

$$\begin{cases} \dot{\xi}_1 = \xi_2 \\ \dot{\xi}_2 = -\dot{V}(\xi_1) - Q(\xi_1, \xi_2)\xi_2 \end{cases}$$

Where the damping function, Q satisfies $Q(0,0) > 0$ and V the free potential scalar function, satisfies $\dot{V}(0) = 0$. This ensures the asymptotic stability of the equilibrium point $(\xi_1^*, \xi_2^*) = (0, 0)$.

In doing so, a natural choice of the mapping π is

$$\pi(\xi) = \begin{bmatrix} \xi_1 \\ -\xi_2 \\ \pi_3(\xi_1, \xi_2) \\ \pi_4(\xi_1, \xi_2) \end{bmatrix} \quad (22)$$

Remark 1: The first condition (C1) is automatically satisfied because the target system is a priori defined.

Remark 2: Linear target dynamics is not, necessarily, suitable because of the constraints imposed by the physical structure and many systems are not linearizable by feedback. Our choice has been made for simplification reasons.

By applying the immersion condition (C2) we obtain:

$$\begin{aligned} \text{For all } \xi \in \mathbb{R}^2 \\ \pi_3(\xi_1, \xi_2) &= \dot{V}(\xi_1) + Q(\xi_1, \xi_2)\xi_2 \\ \text{and} \end{aligned} \quad (23)$$

$$\begin{aligned} \pi_4(\xi_1, \xi_2) &= \frac{\partial \pi_3(\xi_1, \xi_2)}{\partial \xi_1} \xi_2 + \\ &\frac{\partial \pi_3(\xi_1, \xi_2)}{\partial \xi_2} (-\dot{V}(\xi_1) - Q(\xi_1, \xi_2)\xi_2) \end{aligned} \quad (24)$$

$$\frac{\partial \pi_4(\xi_1, \xi_2)}{\partial \xi_1} \xi_2 + \frac{\partial \pi_4(\xi_1, \xi_2)}{\partial \xi_2} (-\dot{V}(\xi_1) - Q(\xi_1, \xi_2)\xi_2) = \varsigma(\pi) \quad (25)$$

From equations (23) and (24) we get $\pi_3(\xi_1, \xi_2)$ and $\pi_4(\xi_1, \xi_2)$ respectively and from equation (25) the mapping $\varsigma(\cdot)$ is defined.

It is easy to define the manifolds of (C3). The manifolds $x_3 = \pi_3(\xi)$ and $x_4 = \pi_4(\xi)$ can be implicitly described by

$$\phi_1(x) \triangleq x_3 - \pi_3(x_1, x_2) \quad (26)$$

$$\phi_2(x) \triangleq x_4 - \pi_4(x_1, x_2) \quad (27)$$

To make the manifold attractive and satisfying (C4), the manifold dynamics is given as

$$\dot{Z} = \begin{pmatrix} \dot{x}_3 - \dot{\pi}_3(x_1, x_2) \\ \dot{x}_4 - \dot{\pi}_4(x_1, x_2) \end{pmatrix} = \begin{pmatrix} x_4 - \pi_4(x_1, x_2) \\ \psi(x, Z) + \frac{\partial \pi_4}{\partial x_1} x_2 - \frac{\partial \pi_4}{\partial x_2} x_3 \end{pmatrix}$$

where $Z = (Z_1, Z_2)^T = \phi(x) = (\phi_1(x), \phi_2(x))^T$

Taking $\dot{Z}_i = -\lambda_i Z_i$ $i = 1, 2$, hence selecting λ_i as positive constants exponentially drives Z_i to the origin. The resulting controller then takes the form

$$\psi(x, \phi(x)) = -\frac{\partial \pi_4}{\partial x_1} x_2 + \frac{\partial \pi_4}{\partial x_2} x_3 - \lambda_2(x_4 - \pi_4(x_1, x_2)) \quad (28)$$

After that, we examine the closed-loop trajectories boundedness. If we consider the extended coordinate system $(x_1, x_2, \rho_1, \rho_2, Z^T)$ with $\rho_1 = x_3 - \pi_3(x_1, x_2)$ and $\rho_2 = x_4 - \pi_4(x_1, x_2)$ using controller (28) for system (21), we obtain the following extended closed loop dynamics:

$$\begin{cases} \dot{x}_1 = -x_2 \\ \dot{x}_2 = \rho_1 + \pi_3(x_1, x_2) \\ \dot{\rho}_1 = \rho_2 \\ \dot{\rho}_2 = -\lambda_2 Z_2 \\ \dot{Z}_1 = -\lambda_1 Z_1 \\ \dot{Z}_2 = -\lambda_2 Z_2 \end{cases} \quad (29)$$

Z_1 and Z_2 exponentially converge toward zero, thus ρ_1 and ρ_2 are bounded for all $t > 0$. Under the suitable choice of V and Q , the subsystem represented by the first two equations of system (29) with input $x_3 = \rho_1 + \pi_3(x_1, x_2)$ is asymptotically stable, consequently all its trajectories are bounded. As matter of fact, this subsystem represents the target system.

Remark 3: It is easy to verify that the control law satisfies $\psi(x, 0) = \varsigma(\pi)$, with $\varsigma(\pi)$ defined by (25), thus the Immersion condition (C2) is satisfied.

Proposition 1: For any mapping satisfying (26) and (27), such that conditions (C3) and (C4) hold using appropriate V and Q , the equilibrium of system (21) in closed loop via controller (28) is asymptotically stable.

The design procedure is conducted by choosing the functions V and Q . For the sake of simplicity, we select $\dot{V} = k_V \xi_1$ and $Q = k_Q$ with $k_V, k_Q > 0$

Then

$$\pi_3(x_1, x_2) = k_V x_1 - k_Q x_2$$

$$\pi_4(x_1, x_2) = -k_Q k_V x_1 + (-k_V + k_Q^2) x_2$$

Finally, doing some computations, the control effort for system (19) is expressed as

$$\bar{u}_3 = -\lambda_{2,x}k_{Q,x}k_{V,x}(x_r - \bar{x}) + (k_{Q,x}k_{V,x} + \lambda_{2,x}(-k_{V,x} + k_{Q,x}^2))\bar{x} + (-k_{V,x} + k_{Q,x}^2)\theta - \lambda_{2,x}\dot{\theta} \quad (30)$$

The same approach is used for system (20), choosing a state vector as $x = (x_1, x_2, x_3, x_4)^T = (y_r - \bar{y}, \bar{y}, \varphi, \dot{\varphi})^T$, and the control law is

$$\bar{u}_2 = -\lambda_{2,y}k_{Q,y}k_{V,y}(y_r - \bar{y}) + (k_{Q,y}k_{V,y} + \lambda_{2,y}(-k_{V,y} + k_{Q,y}k_{Q,y}))\bar{y} + (-k_{V,y} + k_{Q,y}^2)\varphi - \lambda_{2,y}\dot{\varphi} \quad (31)$$

Where $\lambda_{2,(.)}$, $k_{Q,(.)}$ and $k_{V,(.)}$ are positive constants.

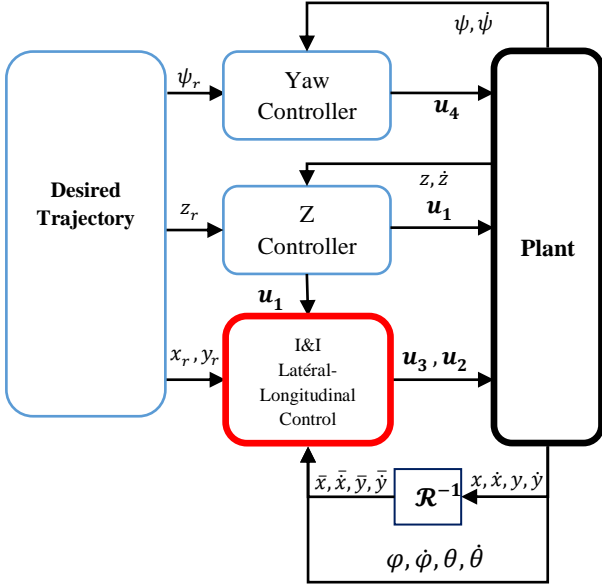

Fig. 3. Controlled system Architecture.

4. EXPERIMENTAL RESULTS

4.1. Gazebo Simulator

Prior the use of experimental tests, we used the simulator Gazebo in order to have a first idea of the vehicle performance and eventually to detect any problem during the flight. The 3D-Gazebo simulator allows testing the control approaches with simulated robots. The main advantage of this simulator is that all control specifications used in the virtual environment of Gazebo could be used with minor changes in the real system. The parameters of the system UAV used in this study are displayed in Table 1.

Table 1. Quad-Rotor parameters

$m(kg)$	0.429	$b(N.sec^2/m^2)$	0.02642
$I_x(kg.m^2)$	0.0022	$d(N.sec^2/m)$	0.00079
$I_y(kg.m^2)$	0.0029	$l(m)$	0.18
$I_z(kg.m^2)$	0.0048		

The desired trajectory is composed of successive line segments. The UAV starts from the origin, then follows an Octagon trajectory using the roll and pitch motions only (the yaw is forced toward the origin). In each corner of the shape, the Quad-Rotor stops 2 seconds (see Figures 4-7), the parameters of control are: $\lambda_x = 35$, $k_{V,x} = 19$, $k_{Q,x} = 12$, $\lambda_y = 20$, $k_{V,y} = 5$, and $k_{Q,y} = 3$.

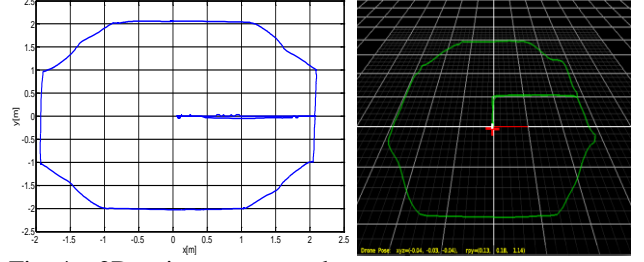

Fig. 4. 2D trajectory- second case

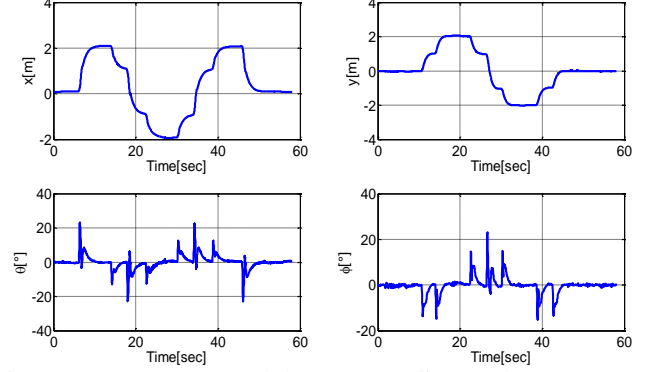

Fig. 5. Outputs (x, y) and the corresponding angles.

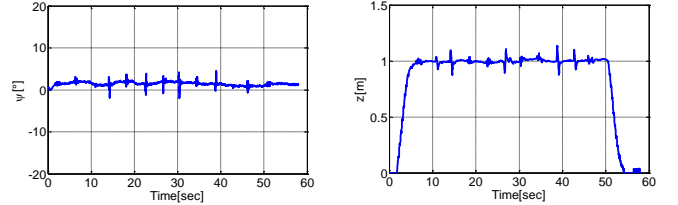

Fig. 6. Yaw angle and altitude.



Fig. 7. Velocities time responses.

In these above Figures, we observe that the vehicle reaches its trajectories with fast and precise manner. The behavior displayed in Figures 5-7 gives an idea on the system stability when the target position is reached.

4.2. Implementation Results

After the virtual environment simulations, the tuned controller is tested on an experimental platform. To show the experimental behavior of the system, we present two types of experimentations. For this task, the tuned parameters are: $\lambda_x = 30$, $k_{V,x} = 7$, $k_{Q,x} = 3$, $\lambda_y = 20$, $k_{V,y} = 4$, and $k_{Q,y} = 1$. Firstly, we have tested the robustness of the proposed controller through preliminary tests. After the

stabilization of the vehicle about the reference trajectory, $((x, y) = (0 \text{ m}, 1 \text{ m}))$ two successive pushes, represented by Pr1 and Pr2, are made as being the external disturbances (see Fig. 8).

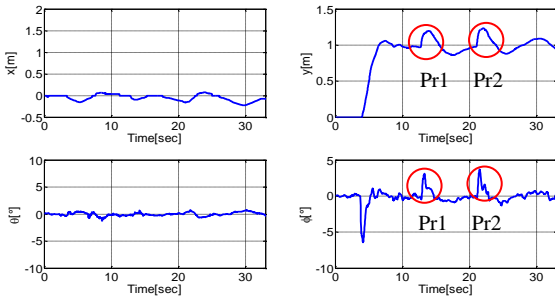

Fig. 8. System time responses in presence of disturbances along the Y-axis.

One may obviously observe that these disturbances are rejected. This result gives a good idea on the controller robustness level. For the last experimentation, we are interested in the turns on junction points (J1, J2, J3, J4) in a combined line segments of a trajectory. To this end, we propose a square trajectory of $1\text{m} \times 1\text{m}$ (see Fig. 9).

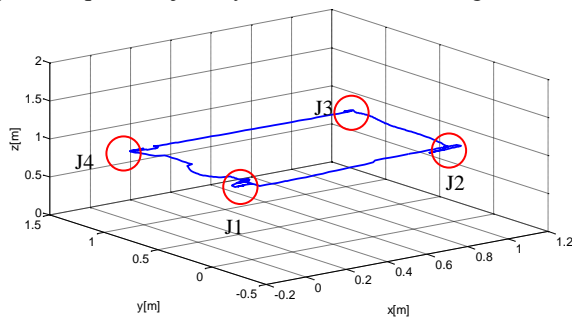

Fig. 9. 3D Square trajectory.

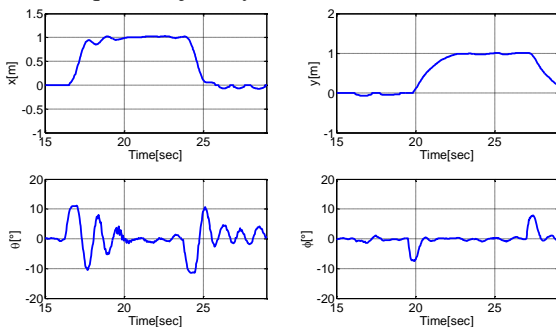

Fig. 10. System time responses for reference square trajectory.

Figures 9 and 10 show that, the outputs rapidly converge to the desired trajectory with a good steady state accuracy. In addition, the proposed controller allows to avoid the occurrence of oscillations during the crossing the junctions points. Notice that these scenarios were done to test the effectiveness of the proposed controller especially when the Quad-Rotor changes its direction. For this purpose, the yaw rotation was forced to be zero (see Fig. 6). Otherwise, the yaw rotation should follow the direction of the trajectory to allow perfect stabilization and to avoid the roll rotation that may cause an overturn if the Quad-Rotor approaches the ground.

5. CONCLUSIONS

The experimental tests performed with the implementation of the controller based on the I&I approach are shown to be successful. It guarantees that the closed-loop system asymptotically behaves like the given target system, which makes the system performance adjustment quite simpler. The objectives are met in terms of stabilization and disturbances rejection. Furthermore, the Quad-Rotor is able to track most of reference trajectories without oscillations when passing through the junction points of two successive arcs or segments of lines.

REFERENCES

- Acosta, J., Ortega, R., Astolfi, A. and Sarras, I. (2008). A constructive solution for stabilization via immersion and invariance: The cart and pendulum system. *Automatica*, vol. 44, No. 9, pp. 2352-2357.
- Alexis, K. Nikolakopoulos, G. and Tzes, A. (2011). Switching model predictive attitude control for a quadrotor helicopter subject to atmospheric disturbances. *Control Engineering Practice*, vol. 19, No. 10, pp. 1195-1207.
- Araar, O. and Aouf, N. (2014). Full linear control of quadrotor UAV: LQ and HN. In: *proceedings of the UKACC international conference on control*, pp.133-138.
- Astolfi, A. and Ortega, R. (2003). Immersion and Invariance: A New Tool for Stabilization and Adaptive Control of Nonlinear Systems. *IEEE transactions on automatic control*, vol. 48, pp. 590-606.
- Bouabdallah, S. (2007). Design and control of Quadrotors with application to autonomous flying. *Doctorate thesis*, EPFL, Zürich.
- Bouadi, H., Cunha, S.S. and Drouin, A. (2011). Adaptive Sliding Mode Control for Quadrotor Attitude Stabilization and Altitude Tracking. *IEEE 12th CINTI*, pp. 449-455.
- Das, A., Subbarao, K. and Lewis, F. (2008). Dynamic inversion of quadrotor with zero-dynamics stabilization. *IEEE International Conference on Control Applications, CCA*, San Antonio, pp. 1189 - 1194.
- Frazzoli, E., Dahleh, M. A. and Feron, E. (2000). Trajectory tracking control design for autonomous helicopters using a backstepping algorithm. *Proceedings of the ACC*, pp. 4102- 4107.
- Hamel, T. and Mahony, R. (2002). Dynamic modelling and configuration stabilization for an x4-flyer. *15th IFAC Triennial World Congress*, pp. 846-846, Barcelona, Spain.
- Hu, J. and Zhang, H. (2013). Immersion and invariance based command-filtered adaptive backstepping control of VTOL vehicles. *Automatica*, vol. 49, pp. 2160-2167.
- Satici, A.C., Poonawala, H. and Spong, M.W. (2013). Robust Optimal Control of Quadrotor UAVs. *IEEE Access*, vol. 1, pp. 79-93.
- Zhang, J., Li, Q., Cheng, N. and Liang, B. (2011). Immersion and Invariance Based Nonlinear Adaptive Longitudinal Control for Autonomous Aircraft. *Proceedings of the 8th World Congress on Intelligent Control and Automation*, pp. 985- 989, Taiwan.
- Zhao, B., Xian, B., Zhang, Y. and Zhang, X. (2014). Immersion and Invariance based Adaptive Attitude Tracking Control of a Quadrotor UAV in the Presence of Parametric Uncertainty. *Proceedings of the 33rd Chinese Control Conference*, pp. 1932- 1937, China.