



**HAL**  
open science

## Predicting the risk of non-compliance to EMC requirements during the life-cycle

Alexandre Boyer, He Huang, Sonia Ben Dhia

► **To cite this version:**

Alexandre Boyer, He Huang, Sonia Ben Dhia. Predicting the risk of non-compliance to EMC requirements during the life-cycle. 2016 Asia-Pacific International Symposium on Electromagnetic Compatibility and Signal Integrity (APEMC2016), May 2016, Shenzhen, China. pp.452 - 455, 10.1109/APEMC.2016.7522766 . hal-01403875

**HAL Id: hal-01403875**

**<https://hal.science/hal-01403875>**

Submitted on 28 Nov 2016

**HAL** is a multi-disciplinary open access archive for the deposit and dissemination of scientific research documents, whether they are published or not. The documents may come from teaching and research institutions in France or abroad, or from public or private research centers.

L'archive ouverte pluridisciplinaire **HAL**, est destinée au dépôt et à la diffusion de documents scientifiques de niveau recherche, publiés ou non, émanant des établissements d'enseignement et de recherche français ou étrangers, des laboratoires publics ou privés.

# Predicting the Risk of Non-Compliance to EMC Requirements During the Life-Cycle

A. Boyer, H. Huang, S. Ben Dhia

CNRS, LAAS, 7 avenue du colonel Roche, F-31400 Toulouse, France  
Univ. de Toulouse, INSA, LAAS, F-31400 Toulouse, France  
alexandre.boyer@laas.fr

**Abstract**—This paper presents a simulation flow for the prediction of the long-term evolution of EMC levels during the life-time of electronic devices or systems. This new requirement is essential to extend the warranty of critical applications operating in harsh environments. The simulation of the evolution of the electromagnetic emission of a switched-mode power supply is given as a validation case.

## I. INTRODUCTION

The consideration of the electromagnetic robustness of electronic devices and systems appeared these last years. It deals with the evolution of parasitic emission and susceptibility to electromagnetic interferences during life cycle for electronic devices operating in harsh environments. Publications such as [1] have shown that the electromagnetic emission (EME) of digital circuits and I/O buffers changes with time because of the activation of intrinsic degradation mechanisms. As presented in only few works, the simulation can be used to predict the long-term EMC behavior. For example, in [2], the simulation results confirm the evolution of the electromagnetic susceptibility (EMS) of a phase-locked loop before and after aging.

The objective of this paper is to present a simulation flow dedicated to the prediction of the long-term EMC (LT-EMC) of electronic devices, i.e. the evolution of the EMC levels due to the aging. The purpose of this study is the evaluation of the risk of non-compliance to EMC requirements. The concept of electromagnetic reliability (EMR) is introduced as an indicator of the risk of non-conformity to EMC requirements. The evolution of the conducted emission produced by a switched-mode power supply (SMPS) submitted to high temperature stress is taken as an example for validation purpose. This methodology could be extended to evaluate the long-term safety, by predicting the evolution of emission and susceptibility levels of devices in a system.

## II. LONG-TERM EMC MODELLING

### A. Prediction of the long-term evolution of the EMC levels

The prediction of the EMC level in nominal condition requires the modeling of electronic devices, PCB traces and planes, cables, test environment... Assembling these different parts form a model which is then simulated to predict the EMC level. The prediction of the LT-EMC level requires further data: the aging models of devices. They consist in a set

of aging parameters and equations that affect the characteristics of stressed device according to the stress duration and conditions. The aging models can be extracted experimentally by a characterization of the evolution of a device properties in stress conditions. Fig. 1 presents a simulation flow for LT-EMC prediction. Knowing the aging models of the devices, the device model parameters can be changed according to the stress conditions and duration, in order to simulate the average evolution of the EMC level.

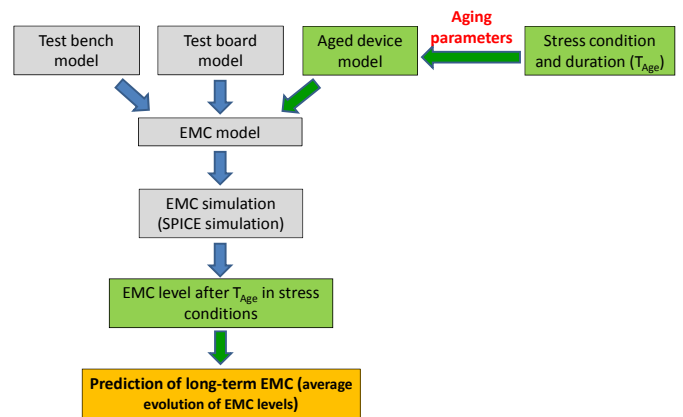

Fig. 1. Long-term EMC simulation flow

### B. Prediction of the electromagnetic reliability

However, because of the dispersion between devices and due to the random nature of aging, predicting the evolution of EMC levels is a statistical problem. Predicting exactly when the EMC level of an electronic system will exceed a certain limit is impossible. Only the probability that EMC levels exceeds this limit after a certain period of stress can be evaluated.

We introduce the notion of electromagnetic reliability (EMR) as the probability that an electronic product remains EMC compliant for a given time period under specified conditions. The complementary notion is the EMC failure probability, which is the probability that a product is no more EMC compliant after a given time period under specified conditions. Determining both functions requires to know the distribution of the EMC levels over the time. Let  $f_t(x)$  the probability distribution function of the EMC level at a given frequency at a time  $t$  and  $F_t(x)$  its cumulative distribution function. For emission tests, the emission levels must not

exceed an emission limit  $x_{lim}$ . The EMR function  $R_{EME}(t)$  is given by (1) as the CDF function at the EMC limit  $x_{lim}$ . The EMC failure function  $F_{EME}(t)$  is given by (2). For susceptibility tests, the susceptibility threshold must be beyond a susceptibility limit  $x_{lim}$ . The definitions of the EMR and EMC failure function  $R_{EMS}(t)$  and  $F_{EMS}(t)$  are thus inverted and given by (3) and (4). Let  $f_{EME}(t)$  or  $f_{EMS}(t)$  the distribution of EMR and EMC failure functions, the mean time to EMC failure (MTTF) is the expected values of both distributions, as given by (5) or (6).

$$R_{EME}(t) = F_t(x_{lim}) \quad (1) \quad F_{EME}(t) = 1 - F_t(x_{lim}) \quad (2)$$

$$R_{EMS}(t) = 1 - F_t(x_{lim}) \quad (3) \quad F_{EMS}(t) = F_t(x_{lim}) \quad (4)$$

$$MTTF_{EME} = \int_0^{+\infty} f_{EME}(t) dt \quad (5) \quad MTTF_{EMS} = \int_0^{+\infty} f_{EMS}(t) dt \quad (6)$$

Fig. 2 describes the EMR simulation flow, which reuses the LT-EMC simulation flow. Device aging models include statistical information about device parameters. A statistical simulation (e.g. Monte-Carlo) is used to sample the aging parameters and compute the EMC levels for each sample. Repeating this simulation a sufficiently large number of times provides the distribution of EMC level after a given stress periods. From this distribution and a given EMC limit, the EMR can be evaluated.

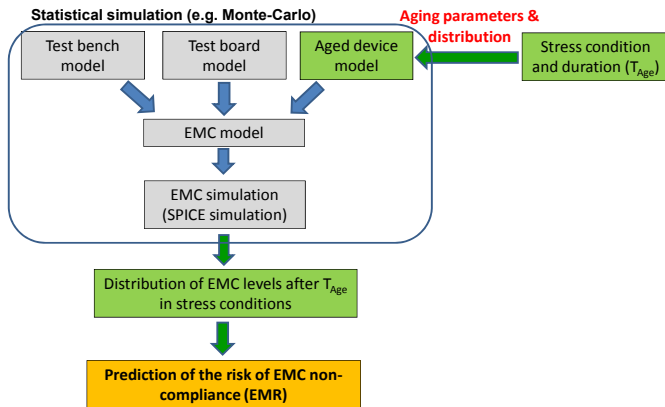

Fig. 2. EMR simulation flow

### III. CASE STUDY: PREDICTING THE LONG-TERM EVOLUTION OF THE ELECTROMAGNETIC EMISSION OF A SMPS

#### A. Case study description

The studied SMPS is based on the NCP3163 monolithic DC-DC converter from On Semiconductor. It is configured in step-down operation, in order to convert the 12 V voltage provided by a battery into a 3.3 V regulated voltage for a constant load equal to 3.4  $\Omega$ . The switching frequency is set to 237 KHz. A simplified schematic of the converter is presented in Fig. 3. The output voltage is adjusted by resistors R1 and R2 through the Feedback pin. The board has been designed to characterize both conducted and radiated emissions from the converter. A 150  $\Omega$  probe is placed on the regulated output node to measure the conducted emission. More details about this case study may be found in [3]. Thermal stress are selected to accelerate the aging of the SMPS. Several

operating boards are placed in a climatic chamber, where the ambient temperature is regulated at 150 $^{\circ}$ c. The maximal stress duration is set to 200 h. During the stress period, the electromagnetic emission is re-characterized several times to monitor its evolution with stress time.

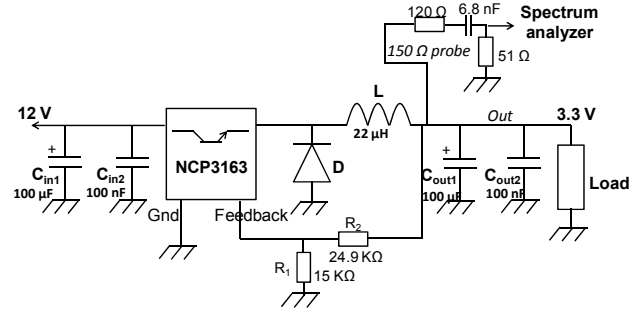

Fig. 3. Schematic of the studied SMPS

#### B. Impact of accelerated aging

Fig. 4 presents a comparison of the conducted emission measured on two SMPS, before and after 200 h stress. The thermal stress induces a wideband and gradual increase of the emission level, which reaches up to 15 dB. This increase is dependent on the stress time and conditions.

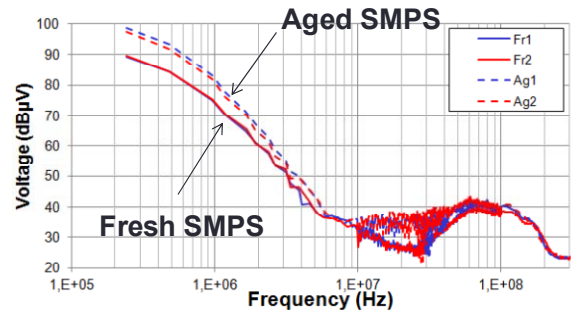

Fig. 4. Evolution of the conducted emission level before and after thermal stress

The analysis of the root-cause of the emission level increase shows the major role of some passive devices, especially the electrolytic aluminum capacitors and iron-powder inductors used as filtering elements, as shown in [3]. The impact on other devices such as the controller NCP3163 and the rectification diode remains insignificant. The thermal stress leads to a change of capacitance and serial resistance for the electrolytic capacitor, as described in [4], and an increase of losses and parasitic capacitance for the inductor.

#### C. Derivation of device aging model

The LT-EMC simulation flow requires the aging models of the stressed device (here electrolytic capacitor and inductor). Electrical models of electrolytic capacitors and inductor have been constructed. Empirical models are derived from experimental characterization of passive devices in order to model the evolution of their impedance according to thermal stress conditions and duration. Details about the models can be found in [3].

The distributions of passive device electrical parameters and the parameters of aging parameters are also extracted from impedance measurements done on stressed devices. Gaussian distributions are assumed ; mean values and standard deviations are extracted experimentally.

#### D. LT-EMC and EMR predictions

A SPICE model of the SMPS has been built in order to simulate its conducted emission, according to the degradation of passive devices induced by the thermal stress [3]. The models of electrolytic capacitors and inductors are affected according to the aging models derived in part C and stress conditions.

Firstly, the average evolution of the conducted emission induced by a thermal stress is simulated according to the simulation flow presented in Fig. 1. Fig. 5-a compares the measured and simulated emission spectra before and after 200 h thermal stress. A good agreement is observed between measurement and simulation. In order to verify if our model is able to predict the gradual evolution of the emission level, the results at two frequencies are considered (237 kHz and 70 MHz). Fig. 5-b presents a comparison of the measured and simulated of the evolution of the conducted emission levels at both frequencies. A good agreement between measurements and simulations is also observed. Depending on the quality of the EMC model and device degradation models, it is possible to predict the long-term trend of the EMC level.

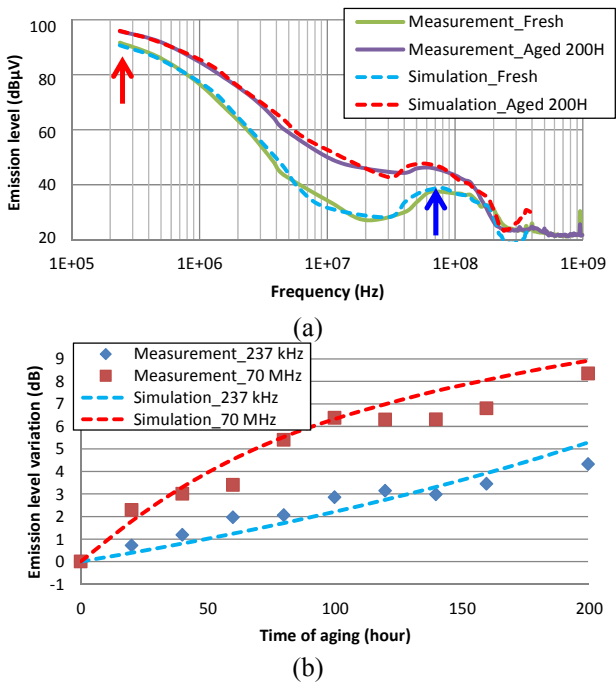

Fig. 5. (a): Measured vs. simulated emission before and after thermal stress; (b): Measured vs. simulated evolution of the emission levels at 237 kHz and 70 MHz

The evaluation of the EMR of the SMPS is based on the simulation of statistical distribution of the emission level. Based on the distributions of passive device model parameters and aging parameters, a Monte-Carlo simulation is performed in order to extract the distribution of the conducted emission

level at each frequency and after different stress periods. The emission level is log-normally distributed and the mean value and standard deviations are extracted.

An emission limit is set to compute the EMR function. Fig. 6 presents a comparison between measured and simulated EMC failure function obtained at 237 kHz and 70 MHz. The evolution of the EMR at 240 kHz is correctly predicted. The MTTF is also correctly estimated. At 70 MHz, even if the simulation predicts correctly the trend for the EMR function, the MTTF is underestimated. The accuracy of the models suffers from the limited number of samples used to extract the statistical distributions. The prediction is thus more sensitive to any erroneous data.

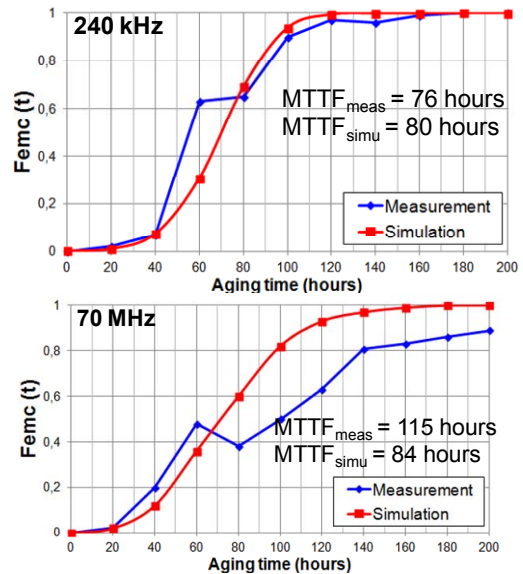

Fig. 6. Measured vs. simulated EMC failure functions according to stress time at 237 kHz and 70 MHz

#### IV. CONCLUSION - DISCUSSION ABOUT LONG-TERM SAFETY

The objective of this work was to propose a simulation flow to predict the long-term evolution of EMC level and the risk of non EMC compliance, called electromagnetic reliability (EMR) in this paper. The proposed methodologies have been successfully applied to predict the evolution of the conducted emission of a SMPS submitted to a thermal stress. These predictions rely on aging models of the stressed devices, extracted from experimental data. The prediction of the evolution of the emission level with age and a comparison with a given EMC limit allow to evaluate the long-term compliance to electromagnetic emission requirements. The previous methodology can also be applied to predict the evolution of the susceptibility levels of an electronic device or equipment. Given a susceptibility limit, the risk of non-compliance to susceptibility requirements can be evaluated as well.

The methodology presented in this paper can be extended to predict the evolution of EMC safety with age and check if the risk of EMC related failures remains acceptable. In an electronic systems, the notion of EMC safety requires to

ensure that sufficient margin exist between the emission and susceptibility levels of the different devices that composes this system. An analysis of the EMC risks induced by the different parts of the system leads to the identification of the emitters and the potential victims within the system. From the extraction of long-term emission and/or susceptibility model, it is possible to predict the average levels and statistical distributions of emission and/or susceptibility levels. From these simulation results, the probability that the EMC margin does not comply to the initial requirements can be evaluated.

## **References**

- [1] A. Boyer, S. Ben Dhia, B. Li, N. Berbel, R. Fernandez-Garcia, "Experimental Investigations on electrical Stress Impact on Integrated Circuit Electromagnetic Emission", IEEE Trans. on EMC, vol. PP, no 99, Feb. 2013.
- [2] A. Boyer, S. B. Dhia, B. Li, C. Lemoine and B. Vrignon, "Prediction of long-term immunity of a phase-locked loop", Proc. IEEE 12th Latin-Amer. Test Workshop, pp.1 -6, 2011
- [3] H. Huang, A. Boyer, S. Ben Dhia, " Passive device degradation models for a electromagnetic emission robustness study of a buck DC-DC converter", EMC Europe 2015, August 2015, Dresden, Germany.
- [4] F. Periss, P. Venet, G. Rojat and J. M. Refif, "Simple model of an electrolytic capacitor taking into account the temperature and aging time," Electrical Engineering, Volume 88, Issue 2, pp 89-95, Sep 2004.