



HAL
open science

A method helping to define eco-innovative systems (Product Architecture + Reverse Supply Chain structure + Use Cycles Scenario)

Nicolas Tchertchian, Dominique Millet, Akram El Korchi

► To cite this version:

Nicolas Tchertchian, Dominique Millet, Akram El Korchi. A method helping to define eco-innovative systems (Product Architecture + Reverse Supply Chain structure + Use Cycles Scenario). 17th CIRP International Conference on Life Cycle Engineering, CIRP, 2010, Hefei, China. hal-01401963

HAL Id: hal-01401963

<https://hal.science/hal-01401963v1>

Submitted on 25 Nov 2016

HAL is a multi-disciplinary open access archive for the deposit and dissemination of scientific research documents, whether they are published or not. The documents may come from teaching and research institutions in France or abroad, or from public or private research centers.

L'archive ouverte pluridisciplinaire **HAL**, est destinée au dépôt et à la diffusion de documents scientifiques de niveau recherche, publiés ou non, émanant des établissements d'enseignement et de recherche français ou étrangers, des laboratoires publics ou privés.

A method helping to define eco-innovative systems (Product Architecture + Reverse Supply Chain structure + Use Cycles Scenario)

Tchertchian N.¹, Millet D.¹, El Korchi A.²

¹ 'Design & Ecodesign Methodology' Lab / Equipe 'Méthodologie de Conception et d'Eco-conception'

S U P M E C A - Toulon, Quartier Mayol, Maison des Technologies, 83000 Toulon, France

² Laboratoire CRET LOG, 413 avenue Gaston Berger, 13625 Aix-en-Provence, France

Abstract

Environmental issues involved by emerging markets and rapid development of goods' consumption require a new model to design product more sustainable. While traditional eco-design methods (LCA, Check-lists, Guidelines, DfX tools...) are generally limited in local optimization of product or macro-rules for environmental strategy, this article presents an eco-innovative method consisting in:

identifying three lists of potential Use-cycles Scenarios (pUS) (SADT activity A2), three lists of potential Products Architectures (pPA) (A3) and three lists of potential Reverse-supply-chain Structures (pRS) (A4), associating pUS, pPA and pRS to form viable concepts of product evaluating these concepts by the way of a multi-criteria approach: environmentally friendly, economically viable for companies and attractive for users and stakeholders. The purpose is to help the design team to develop various levels of change from existing product concept (Use cycles + Product + RSC): optimized, improved and innovative.

Every concept is established by separating at first Architectures produced and structure RSC. In the first time information necessary for the project is collected (current products, current RSC and current usage).

An identification of the new usage provides on one hand the Product design stage and on the other hand the RSC structure construction stage.

The best Architectures and structures are finally associated then assessed environmentally, economically as well as the attractiveness of the customers and the actors of the system in order to select the most successful concepts.

Keywords

Eco-design, Product architecture, RSC structure, Usage

1 INTRODUCTION

The introduction of the environmental dimension in product design is a fundamental priority in our society. Today human kind is at once an actor and a spectator of the first effects of the global warming. The environmental crisis resulting from an increase of the consumption and from a decline of the resources is put however in the background in front of social aspects coupled with the economic challenges. The major industrial nations have to rethink profoundly the way of manufacturing and of consuming to reach a new mode of development: "which meets human needs while preserving the environment so that these needs can be met not only in the present, but also for future generations" [1]. Some measures to reduce the impacts were adopted since around ten years within companies subjected to the public pressure of the policy, the regulations always more restricting and the sensibility of the population in ecological concerns. These measures rely on the development of reprocessing sectors (collecting, recycling and remanufacturing), on the elaboration of new materials (Biofuels, biodegradable materials, eco-materials) [2] on the development of new manufacturing processes (cold injection moulding, thin film deposition), on mechanisms allowing to change the direction of user's behavior (ecofeedback) [3] [4] ... The current ecodesign methods available for the designers are numerous; however they do not allow to cover all these aspects (materials, processes, usage, end of life) and, consequently do not answer completely the requirements of a sustainable development (cf. table 2). Besides, that it is about methods based on LCA evaluations or about the methods based on rules / heuristics recommendations, they are not or little adapted to the practice and to the constraints of the design team [5]. General requirements

expected from an Ecodesign method and formulated by Ernzer [6] are the ease to learn, understand and use, lead to relevant, non abstract and understandable results, the usability in early phases of the product development process or by Fagnoli and Kimura [7] are the effectiveness of the method in assessing environmental performance, the usability, the possibility to review the design activities, and the ability to provide new solution, the ability of the method in fitting into a certain design process. Others requirements are the multidisciplinary implication, the ability to correctly define the performance of product in an exhaustive way (product architecture, usage, organization – Supply chain)

An Ecodesign method must be a tool helping the multidisciplinary design team to take into account all different aspects of the product on the life cycle associate (R&D, Marketing, Customers services, Supply chain, Innovation...).

Current methods do not allow to satisfy generally the requirements of the sustainable development. Indeed they focus mainly on one dimension of the problem without to take into account other dimensions. An ideal method would handle simultaneously technological, functional/usage, economic, environmental and organizational dimensions.

2 REQUIREMENTS FOR A GOOD ECODESIGN METHOD?

A good Ecodesign method must be exploitable by the design team and, more widely the industrial organization (2.1) but also provide all the results/ criteria necessary for the resolution of problems of the sustainable development (criterion of sustainability 2.2). Once these two macro-

criteria are defined, the main developed methods of Ecodesign are estimated through an evaluation grid (2.3).

2.1 Definition of the macro-criterion design team usability

To assess current Ecodesign methods it is necessary to define the functions that they assure for the design team, and more widely the industrial organization. The Ecodesign has an impact in the various departments of the company. The team has to gather the persons in charge of the divisions the most concerned by the process of products development. Indeed they are the most qualified to identify the most relevant working axes to be investigated. Multidisciplinary is a characteristic which must be assured by the method, with the aim of taking into account the numerous dimensions of the system. Brezet identifies 5 services: Management, Marketing, Purchases, Production and R&D [8]. An environmental expert must be integrated in a design team, who can be an internal person to the company or to intervene as to external advisor; in this last scenario it is necessary to establish a learning support allowing to train the members of the design team. In the literature two types of approach are distinguished: the approaches which are situated in upstreams and the one who takes place at the end of design process. Brezet defines the various levels of Ecodesign in 1998 [8]:

- Level 1 : Product improvement
- Level 2 : Product redesign
- Level 3 : Function innovation

- Level 4 : Systems innovation

Products improvement requires an adjustment of the existing products. The redesign of products involves that the components of the product are developed or replaced by others. These two levels concentrate exclusively on products. On the other hand, the functional innovation aims at replacing the services proposed by products, the innovation of the systems involves that new products and services appear, requiring modifications in infrastructures and organizations.

2.2 Definition of the macro-criterion Sustainability

Is the method exhaustive? Does it allow to report all the dimensions of the problem. The approach which we wish to put in to the test aims at handling the economic, environmental and societal aspects.

2.3 Ecodesign methods assessment

The state of the art in Ecodesign approaches shows the existence of numerous approaches which extend from general methods like check-lists or "guidelines" to methods more complex and specialized as the life cycle analysis. We have distinguished four Ecodesign approach:

- LCA oriented Ecodesign approach
- DfX oriented Ecodesign Approach
- Innovation oriented Ecodesign approach
- Simplified Ecodesign approach

		Exploitability criteria to design team					
		Multidisciplinary Method	Learning Support	Multi-Level: Optimization, Improvement, and Innovation	Usability	Stage of design Process	Completeness
LCA oriented Ecodesign approach	LCA [9] [10]	Environmental expert (internal or external)	Need LCA knowledge	Optimization	Environmental expertise Time consuming	Late in design process	Data & expert interpretation uncertainties Boundaries definition
Innovation oriented Ecodesign approach	QFD E [12]	Design team	Need LCC & LCA knowledge	Improvement Innovation	Environmental expertise Time consuming to collect data	early design process	Environmental aspects & customer needs
	LIDS-Wheel [8]	Design team management	No	Improvement Innovation	Step by step guidance	Different time in design process	Life cycle overview
	Eco-Compass [13]	Design team management	Yes Base case (current product)	Improvement Innovation	Compative tool	early design process	Deals with 6 dimensions: environmental, business & customer aspect
Simplified Ecodesign approach	E-FMEA [11]	Environmental expert	E-FMEA design form	environmental improvements	Environmental expertise Recommendations	early design process	Significant environmental aspects: Production, Use and Disposal
	MAIECO [14]	Design team management	Capitalization	Optimization Improvement	Environmental expertise Design guidelines	Full design process	Life cycle vision Environmental profile
	Eco Design Pilot [15]	Design team	The investigation process is not conscious for the users	Optimization	Web tool Step by step guidance	Different time in design process	Life cycle overview Environmental aspect
DfX Oriented Ecodesign approach	Prodtect [16]	Design Team	Base case (current product)	Optimization Improvement	Software tool Technical expertise	Product specification stage design detailed stage	product life cycle: Manufacturing End of life
	DfM [17]	Design Team Environmental expert	No	Optimization Improvement	Software tool	Late in design process	Vision produit Fabrication Assemblage
	Total performance Analysis [18]	Design team	Need LCC & LCA knowledge	improvement	Design guidelines Environmental expertise	Full design process	product life cycle: environmental, economic & customer
	design methodology for upgradable products [19]	Design team	No	innovative	Technical expertise Design guidelines	Full design process	product life cycle: Value Lifetime

Table 1: Assessment of Ecodesign methods according design team point of view

The first tools consist in exploiting in a iterative way a software of Life Cycle Assessment. The LCA tools applied to the current product indeed allows to identify the most impacting components and life cycle stages. Alternative solutions can be proposed; their environmental gain can be finally assessed by modifying the modelling of the life cycle of the current product and by generating simulations with LCA method.

This first category of approach presents advantage and inconveniences associated to the use of the LCA tools. Through a multicriteria evaluation led on the whole life cycle, it allows a rigorous identification (standardized methodology ISO14040 [9]), but this approach uses up too much of the design team's energy as they concentrate on understanding the reasons of environmental impact [20] of past products. This is detrimental to their work of

interpreting and seeking means of improving future products [13]. The development of tools focused on end of life optimization accelerated these last years. The emergence dismantling optimization methods (DfD) [16] [21] as well as of design of modular products (DfM) [22] [15] aim at reorientating the end of life of products towards a better management of the recycling and more at privileging the re-use of modules. While the traditional Ecodesign methods allow a superficial environmental improvement of the current products the Eco-innovation is an approach which allows to decrease radically the environmental impacts while offering some added value to the users and to the economic actors of the product [23]. Among these tools of the product life cycles environmental QFD, Eco-TRIZ, Product System service or Eco-compass is most often found in the literature. The last category of approach is based on the use of simplified tools. Guidelines or check-lists allowing to identify specific axes of improvement with the considered product. Amongst the most known the general guidelines such Ecodesign Pilot [15] or Ten Golden Rules [24] they appear very abstract or very quality focused thus of limited applicability for the design of new systems. More specialized guidelines such as 'electrical and electronic: practical ecodesign guide' exist [25]. These rules are more numerous and detailed generating a local focus which is detrimental to both a more global and a more systemic viewpoint [26]. This limitation of vision may distract the team from the 'right' solutions. Other tools are based on simplified environmental assessments. They distinguish themselves from LCA approach, by being more qualitative and simpler of integration within the company. Amongst these tools MET (materials, Energy, and toxicity) [8] is a multi-criteria tool which allows, quite as the LCA, to identify the environmental concerns during the entire life cycle of the product.

2.4 A new approach to set up

The current Ecodesign methods do not allow to satisfy all the functions to design innovative system compatible with sustainable development. Indeed they are mostly limited to one or two dimensions. The LCA approach allows to treat in a rigorous way the environmental problems but requires an expert whereas the environmental check-lists treat in a more empirical way a complex problem which can be use by multidisciplinary team. Most of the assessing methods allow only local optimizations of the product (LCA, Checklists, Dfd tools). Few methods allow to design innovative systems getting radically new solutions. The societal aspects, as the customers' needs consideration, as well as the economic, are not still taken into account. Now the implementation of new end of life scenarios as the remanufacturing of modules imposes an adaptation of the reverse logistics networks with all the consequences that it involves in terms of infrastructure, localization and management of flows. There are many dfD tools, which allow to optimize the architectures in according product characteristics and the end of life strategy. Unfortunately they generally do not go beyond a simple optimization of the dismantling sequences. The study of some tools shows an inadequacy of the current methods (cf. Table1 & 2) to match the requirements of design of eco-innovative systems.

3 DEFINITION OF THE FOUNDING PRINCIPLES OF THE NEW PROPOSED METHOD

For answering to dissatisfactions revealed by an analysis of the current Ecodesign methods 7 principles were formulated as foundations for a new methodology:

	Sustainable criteria		
	Economic Aspects	Environmental Aspects	Social Aspects
LCA [9] [10]	None	Eco indicator CML, E199 (quantitative)	None
E-FMEA [11]	None	Qualitative environmental impact: Greenhouse effect, Ozone depletion etc)	None
QFD E [12]	Extension possible	Rough assessment Mono-criteria (qualitative or quantitative) e.g. Aggregated Method E199	Voice of Customers of Extended to voice of stakeholders
LiDS-Wheel [8]	None	Base of rules : Materials, Energy, EoL	New concept development
Eco compass [13]	Indirect considerations	Materials energy	Services extension
MAIECO [14]	None	Materials (qualitative) Exhaust gases (qualitative) Toxicity (qualitative)	None
Eco Design Pilot [15]	None	Base of rules (guidelines)	None
Prodtect [16]	Disassembly cost (maximizing profit)	Material Fixtures End of Life optimization: reusable part, recycling parts and hazardous substances	None
DfM [17]	Material cost Manufacturing cost Assembly cost	Aggregated Method E199	None
Total performance Analysis [18]	Life cycle costing Life cycle value	Mono-criteria CO2 emissions [kg-CO2]	Voice of Customers of Extended to voice of stakeholders Obsolescence, technological value
Design methodology for upgradable products [19]	Rough price of each generation	No environmental assessment control	Customers' needs Tends of competitors Company's policy

Table 2: Assessment of Ecodesign methods according sustainability

3.1 A guide helping the designers

The method has vocation to help the design team to develop more relevant solutions. In this particular case, it has to help the members of the design team (Engineering department, Marketing, Supply Chain, Production, R&D) to define the various dimensions of the problem, to generate innovative solutions from new ideas and to assess then to select the most promising on the environmental and economic aspects and which satisfy the users and the other actors of the life cycle of the product. The structure of the method has to give to the design team the guidelines to execute the task of the

method: which data to gather and how to use them to create new solutions, when and how to estimate these solutions and finally how to determine the most relevant solutions for a specific situation.

3.2 A support learning

The method has to facilitate the learning of the design team on various aspects of the environmental concerns; in other words, it has to bring to the foreground and make easier the exchanges between services and the transfers of environmental information. It also has to reveal the profits of an environmental orientation of design team's work and generate a motivation to act.

3.3 A method to act in early design stage

The objective of this method is to help the design team, in the upstream design phases; the final report of this method is the best concept of Eco-innovative system (Product Architecture + RSC Structure + Use-cycles Scenario) on the economic and environmental aspects and on users'/stakeholders' attractiveness. Indeed we focused our efforts on the earlier stage because it corresponds to the stage where the freedom degrees of the design team allows to envisage solutions radically new to be more compatible with a sustainable development.

3.4 A multidisciplinary approach

The design methodology proposed rely on a benchmark of the current product (in terms of usage, product architecture and end of life management) made by all the disciplines involved on the design process; this strategy aims at guaranteeing a progressive evolution of the current industrial system towards a future industrial system more compatible with a sustainable development. Besides, it reveals to the design team (RD, Marketing, supply chain, Engineering department, RSC) ideas and curbs of an orientation towards Eco-innovative products.

3.5 A multi-dimensional design

According to us, any environmental improvement of a product / system recovers either from the improvement of the Use-cycles phase (A2) in particular for products with strong energy consumption or with long lifetime, or the improvement of the materials or processes the most impacting in products specifications in Pre-Life (A3), or implementing end of life treatment to reduce the impacts generated in End-Life (A4). The method is based on the separate developments of a list of potential Product Architectures (pPA) of and a list of potential Reverse-supply-chain Structure (pRS), both lists being fed by a definition of potential Use-cycles Scenario (pUS). The idea is to find the maximum of pPA independently from pRS and pUS, pRS independently from pPA and pUS and pUS independently from pPA and pRS to open in a most exhaustive way the design space.

3.6 An exhaustive method without a priori knowledge

The concepts are obtained by association of the product architectures, of RSC structures and scenarios of potential Use-cycle allow to cover a large number of possible solutions without a priori. The strategy used for this new method consists in privileging no solution a priori (Life cycles scenario, technology or end of life treatment), considering that certain ways can create in A6 unexpected profits (for example economic gains associated to the remanufacturing of a module with strong value added on several life cycles). However, as these Architectures / Structures / Scenarios were independently developed in the previous 2 phases, they are not necessarily compatible; in this fact an adaptation of the architecture of the product can be necessary to adapt itself to a structure of RSC given (and respectively).

3.7 A simultaneous assessment: Environmental, Economic and Attractiveness

Final report of the method is one (or several) concept of Eco-innovative system viable: by viable, we understand a system which is at once acceptable on the economic criterion for the company (and for stakeholders), better for the environment and for all stakeholders implied in one or several life cycles of the product and finally attractive for the user (first and others cycles). The final principle of the

method is to classify the various concepts proposed in a trihedral (economic, environmental and attractiveness criteria).

4 A METHOD HELPING TO DESIGN ECO-INNOVATIVE SYSTEMS

The general structure of the method is based on 7 founding principles expressed in the chapter 3, contains six stages. The SADT formalism (fig. 1) is used to synthesize the main inputs, outputs, resources and controls of these 6 actigrams:

1. Identify needs in information of the project.
2. Define the pUS of the product / system.
3. Define pPA.
4. Define pRS.
5. Associate pPA and pRS.
6. Assess the potential concepts "Architecture+RSC" and select the best concepts.

4.1 A multi-dimensional assessment

This analysis must be driven by integrating all disciplines and the services of the company, in particular the marketing services, R&D, Innovation and Supply-chain. This stage serves just as much to federate all the actors of the design team that to take in all the information necessary for the following stages. This multidimensional analysis is structured in 3 sub stages:

1. The analysis of current product

The current product is decomposed into modules resulting from an internal functional analysis of the product allowing to identify the materials, energy, and information flows. These evaluations will afterward allow to identify components, modules, materials, the most problematic fixtures of the product and thus those for whom the alternatives will firstly have to be looked for.

2. Current RSC analysis

The analysis of the current reverse supply chain, if it exists, starts by modelling the reverse logistics network and process dealing with end-of-life products recovery. For this aim the design team should gather information about reverse logistics facilities locations, transport, warehousing and end-of-life treatment processes. After this, the modelled reverse supply chain is assessed environmentally and economically to identify the cost and environmental impact of the current end-of-life product recovery.

3. The analysis of the current Usage

This sub-stage consists in analysing the current part of service associated with the product (maintenance, repair, optimization of the usage, return). And evaluate the physical lifetime and value lifetime of product.

4.2 Definition of potential Use-cycles Scenario of system

It uses studies on external product aspects, as the analysis of Users trends, Competitors trends or technological trends during several generations to unveil the future products trends. The actigram A2 delivers the following main outputs:

- A list of the fixed / necessary functions
- A list of Short-term upgradable functions: Their integration into the product can't be defined at the beginning of first cycle.
- A list of long-term upgradable functions: Their integration into the product can be only functionally defined.

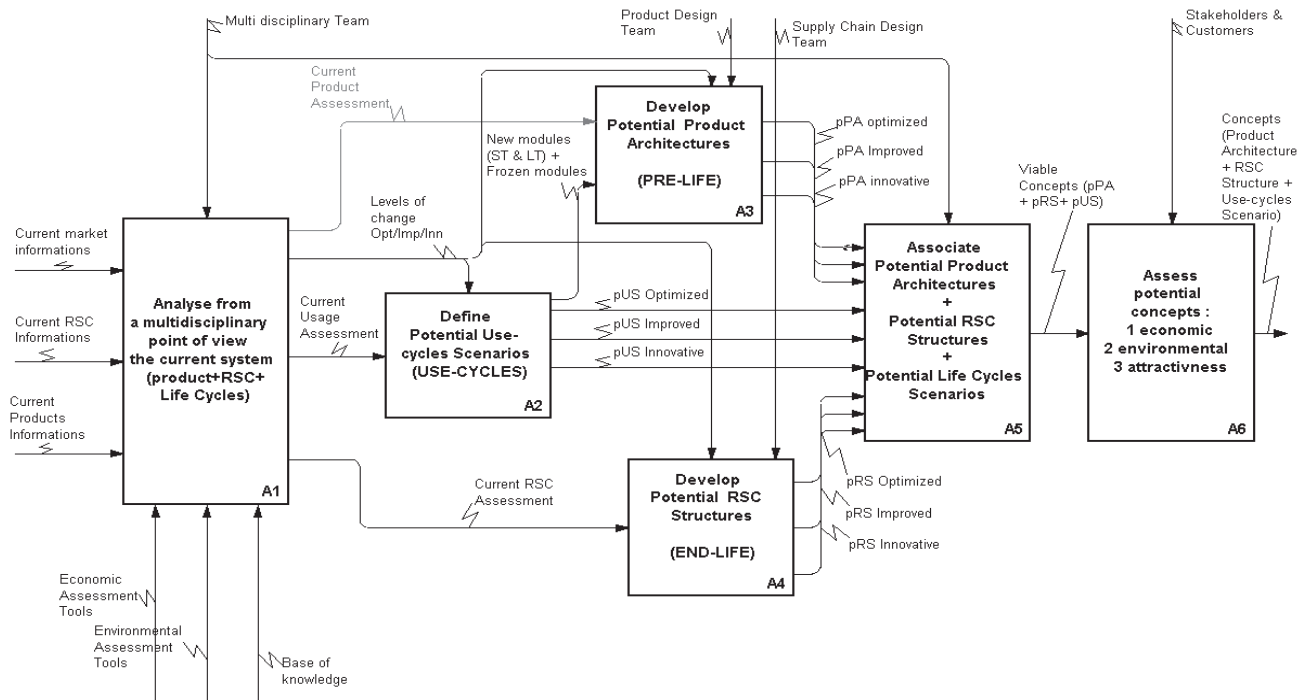

Figure 1: Framework of Method helping to define eco-innovative systems

The phase A2 provides data for the phases A3 ("Pre-Life") and A4 ("End-Life").

4.3 Definition of potential product architectures

The purpose of the actigram A3 is to propose pPA: that is modular architecture consisted of remanufacturable modules, recyclable modules and upgradable modules. Three levels of architectures are distinguished (optimization, improvement and innovation) corresponding to the various evolutions of usage identified in the precedent actigram (necessary functions, short-term upgradables and long-term upgradables functions).

The actigram A2 delivers the following main outputs:

- Optimized pPA: The fixations are modified (types, quantity and orientation), facilitating the extraction of reusable modules, some materials are substituted with the aim of optimizing and homogenizing the process of recycling.
- Improved pPA: Some modules can be modified (i.e. to improve reliability) or added into the product architecture allowing a functional short-term upgrade.
- Innovative pPA: The product architecture is modified; modules are added or removed without limitation allowing a functional short-term and long-term upgrade.

4.4 Definition of potential RSC structures

After the analysis and the evaluation of the current RSC structure, different ways of improvement can be imagined. This is the object of the activity A4 of the SADT. The input is a set of 18 generic structures of RSC (gRS). The generic structures are obtained by varying the role (Inspection and Sorting of Modules: ISM, Dismantling and Cleanig: DC and Inspection and Sorting of Products: ISP) of each actors (Customers: C, Grouping Center: GC and Product Center: PC), three level of change can be found corresponding to the following potential reverse supply chain structures:

- Optimized pRS: The Optimized RSC structure is obtained by changing the location and the number of facilities in the current reverse logistics network.

- Improved pRS: The selected generic structures are adapted to specificity of the firm's business to obtain potential improved RSCs. For this aim, a radical change on the role of actors and locations for end of life treatment would be necessary.
- Innovative pRS: The selected generic structures are adapted to specificity of the firm's business to obtain innovative pRS. the innovation the reverse supply chain should supported by the innovation in the product design and a radical change in the customer culture.

4.5 Association of better PPA and PRSCS

The association of the phases A2, A3 and A4 allows to constitute associations between product architectures, RSC structures and life cycle scenario. Designed independently, it is necessary to adapt them each other. This work must be done with help of the design team

4.6 Multi-criteria assessment (environmental, economic et functional) of potential product + RSC concepts

The activity A6 is a phase of multi-criteria assessment and selection of the final concept (Product + RSC + Use-cycle scenario). The final selection is connected to the performance of the concept in three criteria "sustainable development": acceptable for environment, viable economically for the company and attractive for the user. We proceed by 3 parallel evaluations which can be independently made: an environmental assessment bringing some value to the society, an economic assessment for the company and an evaluation of the attractiveness with regard to the values perceived by the customer. Finally all the estimated concepts are organized into a hierarchy in on a trihedral for choice.

5 CONCLUSIONS

The objective of this research was to formalize a new method to help the design team to define eco-innovative systems (product architecture + RSC structure + Use-cycle scenario) enabling them to choose the most promising solutions/options as early as possible in the design process. The proposed tool responds to the

general requirements for Ecodesign tools formulated by Ernzer [6]:

- Easy to learn, understand and use
 - Lead to relevant, non-abstract and understandable results
 - Useful in early phases of the product development process
 - Not be a stand-alone activity
- or by Fargnoli and Kimura [7]:
- Ability to correctly define the performance of product
 - Usability
 - Effectiveness of the method in assessing environmental performance
 - Ability to provide new solutions
 - Possibility to review the design activities
 - Ability of the method in fitting into a certain design process.

The research work is in an initial stage of development: further studies concerning both the definition of more precise assessment criteria of the methods, as well as their verification throughout different industrial applications are certainly needed.

REFERENCES

- [1] World Commission on Environment and Development (WCED) (the Brundtland Report) (1987) *Our Common Future*, London: Oxford University Press.
- [2] Dovi, V G., Friedler, F., Huisingh, D., and Klemeš, J J. (2009) Cleaner energy for sustainable future, *Journal of Cleaner Production*, Vol. 17, No. 10, pp.889–895.
- [3] Lilley, D. (2009) Design for sustainable behavior: strategies and perceptions, *Design Studies*, 30, pp.704–720.
- [4] Hirschl, B., Konrad, W., and Scholl, G. (2003) New concepts in product use for sustainable consumption, *Journal of Cleaner Production*, Vol. 11, No. 8, pp.873–881.
- [5] Millet, D., Tchertchian, N. and Brissaud, D. (2009) 'How to identify the most promising areas of environmental improvement at the early stages of the design process?', *Int. J. Design Engineering*, Vol. 2, No. 3, pp.299–319
- [6] Ernzer, M., Lindahl, M., Masui, K. and Sakao, T. (2003) 'An international study on utilisation of design for environment methods (DfE) – a pre-study', Third International Symposium on Environmentally Conscious Design and Inverse Manufacturing, Japan.
- [7] Fargnoli, M. and Kimura, F. (2006) 'Sustainable design of modern industrial products', 13th CIRP International Conference on Life Cycle Engineering, Leuven.
- [8] Brezet H., Hemel C., (1997), *ECODESIGN – A promising approach to sustainable production and consumption*, UNEP publication, ISBN928071631-X.
- [9] Goedkoop, M., Effting, S. and Collignon, M. (2000) *The Eco Indicator 99: A Damage Oriented Method for Life Cycle Impact Assessment-Manuel for Design*, 2nd ed., Amersfoort, The Netherlands.
- [10] ISO 14040 (1997), *Management environnemental - Analyse de Cycle de Vie - Principes généraux et cadre*.
- [11] Lindahl, M. (1999), "E-FMEA - A New Promising Tool for Efficient Design for Environment," First International Symposium on Environmentally Conscious Design and Inverse Manufacturing,
- [12] Ernzer M., Oberender C., Birkhofer H. Methods to support ecodesign in the product development process. *Going Green - Care Innovation 2002*. Vienna, 2002.
- [13] Fussler, C. and James, P. (1996) *Driving Eco Innovation: A Breakthrough Discipline for Innovation and Sustainability*, Pitman Publishing, London.
- [14] Standard XP E 01-005, (2008) - According MAEICO Methodology.
- [15] Wimmer, W. and Züst, R. (2003) 'ECODESIGN Pilot, product-investigation-, learning- and optimization-tool for sustainable product development', *Alliance for Global Sustainability Book Series*, Vol. 3, p.112,
- [16] Hallmann, U., Herrmann, C., Maas, H. (2004) *ProdTect, the Tool for Product Architects: Turning Challenges of Predictive Design into Uniques Selling Points*, Global Conference on Sustainable Product Development and Life Cycle Engineering, Berlin.
- [17] Tseng H.-E., Chang C.-C., Li J.-D., *Modular design to support green life-cycle engineering. Expert Systems with Applications*,34:25, 24–37, 2008.
- [18] Umeda, Y., Takeda H., 2005, *Development of design methodology for upgradable products based on function-behavior-state modeling. Artificial Intelligence for Engineering Design, Analysis and Manufacturing (AI EDAM)*, 19: 161-182.
- [19] Kondoh, S., Masui, K.,Hattori, M., Mishima, N. and Matsumoto, M. (2008) 'Total performance analysis of product life cycle considering the deterioration and obsolescence of product value', *Int. J. Product Development*, Vol. 6, Nos. 3/4, pp.334.352.
- [20] Millet, D., Bistagnino, L., Lanzavecchia, C. and Camous, R. (2005) 'Does the potential of the use of LCA match the design team needs?', *Journal of Cleaner Production*, Vol. 15, No. 4, pp.335–346.
- [21] Haoues N. *Contribution à l'intégration des contraintes de désassemblage et de recyclage dès les premières phases de conception de produits*. Paris: Ecole Nationale Supérieure d'Arts et Métiers Centre de Paris, 2005.
- [22] Kimura F, Kato S, Hata T, Masuda T. Product modularization for parts Reuse in inverse manufacturing. *Annals of CIRP*, 50, 2001, pp.89-92.
- [23] James, P., 1997; 'The Sustainability Circle: a new tool for product development and design', *Journal of Sustainable Product Design 2*: 52:57
- [24] Luttrupp, C. and Lagerstedt, J. (2006) 'Ecodesign and the Ten Golden Rules: generic advice for merging environmental aspects into product development', *Journal of Cleaner Production*, Vol. 14, Nos. 15–16, pp.1396–1408.
- [25] Rodrigo, J. and Castells, F. (2002) *Electrical and Electronic Practical Ecodesign Guide*, University Rovira i Virgili, Tarragona, Spain, ISBN 84-8424-010-X.
- [26] Boothroyd, G. (1993) 'Cutting out the excess', *Manufacturing Breakthrough*, May–June, Vol. 2, No. 3, pp.21–27.

Contact

Nicolas Tchertchian
Supmeca Toulon, LISMMA laboratory,
Maison des technologies, 83000 Toulon, France,
Nicolas.tchertchian@supmeca.fr