



HAL
open science

Benthic and fish aggregation inside an offshore wind farm: Which effects on the trophic web functioning?

Aurore Raoux, Samuele Tecchio, Jean-Philippe Pezy, Géraldine Lassalle, Steven Degraer, Dan Wilhelmsson, Marie Cachera, Bruno Ernande, Camille Le Guen, Matilda Haraldsson, et al.

► To cite this version:

Aurore Raoux, Samuele Tecchio, Jean-Philippe Pezy, Géraldine Lassalle, Steven Degraer, et al.. Benthic and fish aggregation inside an offshore wind farm: Which effects on the trophic web functioning?. Ecological Indicators, 2017, 72, pp.33 - 46. 10.1016/j.ecolind.2016.07.037 . hal-01398550

HAL Id: hal-01398550

<https://hal.science/hal-01398550v1>

Submitted on 19 May 2020

HAL is a multi-disciplinary open access archive for the deposit and dissemination of scientific research documents, whether they are published or not. The documents may come from teaching and research institutions in France or abroad, or from public or private research centers.

L'archive ouverte pluridisciplinaire **HAL**, est destinée au dépôt et à la diffusion de documents scientifiques de niveau recherche, publiés ou non, émanant des établissements d'enseignement et de recherche français ou étrangers, des laboratoires publics ou privés.

Benthic and fish aggregation inside an offshore wind farm: Which effects on the trophic web functioning?

Raoux Aurore ^{1,2,*}, Tecchio Samuele ¹, Pezy Jean-Philippe ², Lassalle Géraldine ³, Degraer Steven ⁴,
Wilhelmsson Dan ⁵, Cachera Marie ⁷, Ernande Bruno ⁶, Le Guen Camille ¹, Haraldsson Matilda ¹,
Grangeré Karine ¹, Le Loc'h François ⁷, Dauvin Jean-Claude ², Niquil Nathalie ¹

¹ Normandie Université UNICAEN, UMR BOREA (MNHN, UPMC, UCN, CNRS-7208, IRD-207) CS 14032, 14000 Caen, France

² Normandie Université UNICAEN, UMR M2C (UCN, UR, CNRS-6143), 24 rue des Tilleuls, 14000 Caen Cedex, France

³ IRSTEA, UR EABX (Aquatic Ecosystems and Global Changes), 50 avenue de Verdun, 33612 Cestas Cedex, France

⁴ Royal Belgian Institute of Natural Sciences (RBINS), Operational Directorate Natural Environment (OD Nature), Marine Ecology and Management (MARECO) Gulledele 100, 1200 Brussels, Belgium

⁵ The Royal Swedish Academy of Sciences Box 50005, SE-104 05 Stockholm, Sweden

⁶ IFREMER, Laboratoire Ressources Halieutiques, 150 quai Gambetta, BP 699, 62321 Boulogne sur Mer, France

⁷ Laboratoire des Sciences de l'Environnement Marin, UMR 6539 LEMAR (CNRS/UBO/IRD/Ifremer), Institut Universitaire Européen de la Mer (IUEM), Technopôle Brest-Iroise, Rue Dumont d'Urville, 29280 Plouzané, France

* Corresponding author : Aurore Raoux, email address : aurore.raoux@unicaen.fr

Abstract :

As part of the energy transition, the French government is planning the construction of three offshore wind farms in Normandy (Bay of Seine and eastern part of the English Channel, north-western France) in the next years. These offshore wind farms will be integrated into an ecosystem already facing multiple anthropogenic disturbances such as maritime transport, fisheries, oyster and mussel farming, and sediment dredging. Currently no integrated, ecosystem-based study on the effects of the construction and exploitation of offshore wind farms exists, where biological approaches generally focused on the conservation of some valuable species or groups of species. Complementary trophic web modelling tools were applied to the Bay of Seine ecosystem (to the 50 km² area covered by the wind farm) to analyse the potential impacts of benthos and fish aggregation caused by the introduction of additional hard substrates from the piles and the turbine scour protections. An Ecopath ecosystem model composed of 37 compartments, from phytoplankton to seabirds, was built to describe the situation “before” the construction of the wind farm. Then, an Ecosim projection over 30 years was performed after increasing the biomass of targeted benthic and fish compartments. Ecological Network Analysis (ENA) indices were calculated for the two periods, “before” and “after”, to compare network functioning and the overall structural properties of the food web. Our main results showed (1) that the total ecosystem activity, the overall system omnivory (proportion of generalist feeders), and the recycling increased after the construction of the wind farm; (2) that higher trophic levels such as piscivorous fish

species, marine mammals, and seabirds responded positively to the aggregation of biomass on piles and turbine scour protections; and (3) a change in keystone groups after the construction towards more structuring and dominant compartments. Nonetheless, these changes could be considered as limited impacts of the wind farm installation on this coastal trophic web structure and functioning.

Highlights

- ▶ Ecopath models before/after an offshore wind farm were built. ▶ Possible reef effect would increase total system biomass by 55%. ▶ Bivalves build-up would lead to a food web dominated by detritivory.
- ▶ Benthos and keystone fish biomass increases attracted apex predators.

Keywords : Marine renewable energies, Reef effect, Wind farm, Ecopath with Ecosim, Ecosystem-based approach

47 **1. INTRODUCTION**

48 Humanity's ever growing energy demands have translated into an increase in fossil fuel combustion and
49 greenhouse gases emissions and, consequently, into global climate changes (OSPAR, 2008; IPCC, 2014). A
50 new focus on renewable energy source research and development arose during the last decades to counter
51 this trend. The European Union (EU) has set a target of 20% of energetic consumption derived from
52 renewable energy sources by 2020 (Directive 2009/28/EC). With more than 11 million km² of waters under
53 its jurisdiction, France holds a huge natural potential for marine renewable energy (MEDDE 2011). Currently,
54 the construction of six offshore wind farms is planned in metropolitan France. Among them, three should be
55 built in the central-eastern part of the English Channel: the Courseulles-sur-mer (~50 km², 75 wind turbines),
56 the Fécamp (~65 km², 83 wind turbines) and the Tréport (~67 km², 62 wind turbines) offshore wind farms.
57 The implementation of this type of infrastructure is a challenge for developers from technical, legal, social,
58 and environmental points of view. Indeed, these offshore wind farms will be integrated into ecosystems
59 already subjected to a growing number of anthropogenic disturbances such as pollution, transport, fishing,
60 aquaculture, aggregate extraction, or sediment dredging and deposit.

61 Concern about the potential environmental impacts generated by these new structures on marine
62 ecosystems arose from this development (Lindeboom et al., 2011; Bailey et al., 2014). The exploration,
63 construction, operation, and decommissioning of offshore wind farms can indeed be responsible for
64 temporary and/or permanent impacts on marine ecosystems such as the destruction of seabed or the
65 disturbance of fish and marine mammal populations (Shields et al., 2014; OSPAR, 2008; Mueller-Blenkle et
66 al., 2010). During the construction phase, if special care is taken to protect rare habitats and spatial and
67 temporal habitat use by sensitive species, effects can be kept relatively small or negligible (e.g. Wilhelmsson
68 et al. 2010). During the operational phase, the anticipated and recorded disturbances caused by noise,
69 vibrations and the electromagnetic fields are also in most cases considered to be of minor importance to the
70 marine environment, at least to date (Westerberg et al., 2008; Petersen and Malm, 2006, Wilhelmsson et al.
71 2010). However, a noteworthy effect of the introduction of turbines with their associated scour protection is
72 the creation of new habitats and shelters that will be immediately colonized by several marine species
73 resulting in an additional source of food for higher trophic levels (Bergström et al., 2013). This effect,
74 generally known as the "reef effect", is considered as one of the most important effect on the marine
75 environment generated by the construction of offshore wind farms (Peterson and Malm, 2006; Langhamer,
76 2012; De Mesel et al., 2015). The reef effect has been described for epibenthic and demersal fauna as well
77 as on benthopelagic fish (including commercial species) in the direct proximity of wind farm foundations
78 (Wilhelmsson et al., 2006; Tougaard et al., 2006; Wilhelmsson and Malm, 2008; Maar et al., 2009; Reubens et
79 al., 2011; Leonhard et al., 2011; Lindeboom et al., 2011; Bergström et al., 2013; Reubens et al., 2013; Reubens
80 et al., 2014; Degraer et al., 2014). The reef effect has also been demonstrated for other anthropogenic

81 structures such as shipwrecks and oil platforms (Wolfson et al., 1979; Love et al., 1994, 1999; Wilhelmsson
82 et al., 2006). The choice of material and the shape of the structures introduced in the marine environment
83 both play an important role during the colonization process (e.g. Andersson et al., 2010). All these previous
84 studies provide a vast amount of data on environmental effects at the species or community scales. However,
85 the propagation of the reef effect at the ecosystem scale, impacting the structure and functioning of food
86 webs remains unclear (Boehlert and Gill, 2010).

87 Until now, there is no holistic study on the effects of the construction and operation of offshore wind farms
88 on an ecosystem taken as a whole. Here, we propose to develop a holistic view of offshore wind farm impacts
89 on ecosystems functioning through the use of trophic web modelling tools. Our work will provide information
90 on the food web change in response to the construction and operation of marine energy infrastructures,
91 information which is essential to the sustainable development and management of renewable energy
92 sources. The main feature of this work will be to propose a methodology that is complementary to what it is
93 currently applied in Environmental Impact Assessments by using: (1) a holistic approach in which the
94 ecosystem represents the management unit, (2) a functional perspective based on flows of energy circulating
95 between ecosystem components, and (3) a high level of functional diversity to describe the food web.

96 Among the different existing modelling approaches, Ecopath with Ecosim (EwE) has been intensively
97 developed and used over the last three decades and was applied on hundreds of aquatic ecosystems
98 throughout the world (Polovina, 1984; Christensen and Walters, 2004; Christensen et al., 2008). This
99 approach, in which all biotic components of the system are considered at the same time, provides measures
100 of the ecosystem emergent properties through the calculation of Ecological Network Analysis (ENA) indices
101 (Ulanowicz, 1986). These joint analyses have been frequently applied to coastal and marine systems to assess
102 changes in their functioning in response to environmental perturbations (Ortiz and Wolff 2002, Rybarczyk et
103 al., 2003; Patricio et al., 2006; Niquil et al., 2012; Tecchio et al., 2013, 2015). Some ENA indices, such as the
104 redundancy, have also been linked to notions of stability (Christensen et al., 2005) such as the resilience of
105 trophic webs to perturbations (Heymans et al., 2007). Finally, ENA indices have also been proposed as trophic
106 descriptors of ecosystem health for the EU Marine Strategy Framework Directive (Dame and Christian 2007;
107 Niquil et al., 2012; Rombouts et al., 2013; Niquil et al., 2014).

108 The objective of the present study was to model the potential impacts of the construction and operation of
109 the Courseulles-sur-mer (southern part of the Bay of Seine along the Calvados coast) offshore wind farm on
110 the local trophic-web functioning. Special attention was paid on how benthos and fish aggregation caused by
111 the introduction of additional hard substrates from the piles and the scour protections might lead to the
112 development of an artificial reef system, and also what the consequences on the food-web functioning could

113 be. To analyse the impact of additionally available hard substrates, an Ecopath model was first built to
114 describe the food web before the construction of the Courseulles-sur-mer offshore wind farm and then an
115 Ecosim model was derived to project over the next 30 years the ecosystem evolution after the forced increase
116 in biomass of some targeted benthic and fish compartments in relation to the wind farm construction. For
117 this, observations of species changes in wind farm areas obtained through extensive literature searches were
118 adapted to the Courseulles-sur-mer site based on expert knowledge. Two hypotheses regarding the food-
119 web functioning were particularly investigated with Ecosim simulations: (i) a system dominated by mussels
120 leads to a more detritivorous food web (Norling and Kautsky, 2008), and (ii) the increased biomass of benthic
121 invertebrates and fish, as generated by the reef effect, would attract apex predators (Lindeboom et al., 2011;
122 Henkel et al., 2014). This is, to our knowledge, the first attempt to study the potential impacts of the
123 construction and operation of an offshore wind farm on the local trophic web structure and functioning using
124 an integrated ecosystem modelling approach.

125 **2. MATERIAL AND METHODS**

126 **2.1 Study area**

127 The Bay of Seine, where the offshore wind farm will be built in the next years (from 2018) is located on the
128 north-western French coast and opens onto the eastern English Channel (Fig. 1). The Bay of Seine forms an
129 approximate quadrilateral of 5000 km², with a mean depth of about 20 m. The water depth never exceeds
130 35 m. The maximum tidal range is 7.5 m in the eastern part of the Bay near the mouth of the Seine estuary.
131 Tidal currents average between 1 and 2 knots in the southern sector of the Bay, and their intensity gradually
132 diminishes toward the eastern Bay of Seine (Salomon and Breton, 1991, 1993). The distribution of superficial
133 sediments and benthic communities is strongly correlated to these currents (Gentil and Cabioch, 1997;
134 Dauvin, 2015). There is an offshore-inshore gradient in the Bay, with the dominant sediment offshore
135 generally consisting in pebbles, gravel and coarse sands and the sediment inshore in the coastal zones
136 consisting mostly of fine sands and muddy fine sands (Dauvin et al., 2007, 2015). Benthic communities of the
137 Bay of Seine are well described in terms of composition and spatial distribution (Dauvin and Ruellet, 2008)
138 and were demonstrated to be good indicators of ecosystem health (Garcia, 2011). Coastal marine, estuarine
139 and mixed systems along the French coasts are predicted to be high sensitive to climatic variations (Goberville
140 et al., 2010). The Bay of Seine ecosystem is already submitted to multiple anthropogenic disturbances such
141 as maritime traffic, fishing, and sediment dredging (Dauvin et al., 2004). All these features make it a system
142 at the crossroad of various influences, central for studying cumulative impacts on the functioning of marine
143 ecosystems.

144 **2.2 Courseulles-sur-mer offshore wind farm project**

145 The project is owned by “Eoliennes Offshore du Calvados”, a subsidiary of Éolien Maritime France and wpd
146 Offshore. EMF was allowed to operate the offshore wind farm off from Courseulles-sur-mer by the Ministerial
147 Order of April 18th 2012. The proposed wind farm will be located 10 to 16km offshore from the coast of
148 Calvados – Normandy. The depth range is 22-31 m at Lowest Astronomical Tide (LAT to be checked). The
149 wind farm will have a total area of approximately 50 km² (Fig. 1). The wind farm will comprise 75 6MW
150 turbines giving a combined nameplate capacity of 450MW. The wind farm turbines will be connected via
151 an interarray network of 33 kV AC cables which will link at one offshore transformer substation located within
152 the wind farm. From this station power will be exported via two 225 kV AC marine cables. The turbines are
153 supported by 7 m of diameter monopiles driven into the sea bed. The foot print of the 75 turbines foundation
154 and of the converter station will be 0.158 km² or 0.03% of the overall wind farm area. Our work hypothesis
155 was that scour protections will be installed around the 75 turbines and the converter station and 33% of the
156 cables will be rock-dumped, thus the total additional surface would amount to 0.342 km², or 0.72% of the
157 offshore wind farm area when considered in two dimensions. In calculating the biomasses changes we took
158 into account the actual “foot print” of the new structure: while in terms of surface it will be low, the
159 colonization of the structure will happen in three dimensions including the whole pillar. The production
160 generated by the wind park would cover the average annual electricity consumption of approximately
161 630,000 people, i.e. around 40% of the inhabitants of the surrounding region of Normandy.

162 <Figure 1>

163 **2.3 Presentation of the trophic modelling approach**

164 The *Ecopath with Ecosim* (EwE) software (Polovina, 1984; Christensen and Walters, 2004; Christensen et al.,
165 2008) was used to model the food web at the site of the construction of the future Courseulles-sur-mer
166 offshore wind farm. Among the different EwE modules, Ecopath is designed to build a snapshot of the
167 ecosystem functioning while Ecosim allows simulating its dynamic evolution through time. Ecopath is a mass-
168 balance (i.e. neglecting year-to-year changes in biomass compared to flows), single-solution model (i.e.
169 returning only one value per flow), that estimates fluxes between a set of established trophic compartments.
170 Each compartment corresponds to a single species or a group of species similar in terms of predators, preys
171 and of metabolic rates (i.e. trophic group). It is parameterised with biomasses (B, gC.m⁻²), production over
172 biomass ratios (P/B, year⁻¹), consumption over biomass ratios (Q/B, year⁻¹) and a diet matrix (DC= diet
173 composition) which establishes the interactions between predators and preys in the ecosystem.

174 The parameterization of an Ecopath model is based on satisfying two equations. The first one (Eq. 1) describes
175 the production for each compartment in the system as a function of the consumption ratio (Q/B) of its

176 predators (j), the fishing mortality (Y_i , gC.m⁻²), the net migration (E_i ; emigration – immigration, year⁻¹), the
 177 biomass accumulation (BA_i , year⁻¹), and its natural mortality ($1 - EE_i$). EE corresponds to the Ecotrophic
 178 Efficiency or the proportion of biomass consumed in the system for each compartment in the system.

$$179 \quad B \left(\frac{P}{B} \right)_i = \sum_j B_j \left(\frac{Q}{B} \right)_j DC_{ij} + Y_i + E_i + BA_i + B_i \left(\frac{P}{B} \right)_i (1 - EE_i) \quad (\text{Eq. 1})$$

180 The second equation (Eq. 2) describes the energy balance within a compartment.

$$181 \quad Q_i = P_i + R_i + U_i \quad (\text{Eq. 2})$$

182 The energy balance of each group in equation 2 is assured by making consumption of the i^{th} group (Q_i) equal
 183 to the sum of its production (P_i), respiration (R_i , gC.m⁻²), and excretion of unassimilated food (U_i).

184 **2.4 Parameterisation of the Ecopath model describing the situation before the wind farm**

185 The selection and aggregation of functional groups included in the Ecopath model was based on biological
 186 and ecological characteristics of the species such as their food preference, size, and commercial importance
 187 as well as on data availability. On this basis, 37 groups were retained (Table 1, Fig. 2), two of which were
 188 seabirds, four marine mammals, eighteen fish, nine invertebrates, one zooplankton, one primary producers,
 189 one bacteria, and one detritus group.

190 <Table 1>

191 <Figure 2>

192 **2.4.1 Seabirds**

193 Abundance data were collected from the 41 boat surveys conducted by the Normandy Ornithological Group
 194 (GONm) on a monthly basis, from January 2008 to December 2010 (Morel, 2013). The Bay of Seine is on the
 195 migration route and wintering area for many marine birds. Consequently, the proportion of prey captured
 196 outside the area was considered as imports in seabird diets. The species observed inside the implantation
 197 area of the future Courseulles-sur-mer offshore wind farm were grouped into two categories according to
 198 their main feeding strategies. The “Plunge and pursuit divers” were composed of northern gannets (*Sula*
 199 *basana*), loon (*Gavia* sp.), auks (common mures *Uria aalge*, razorbills *Alca torda*), cormorant (*Phalacrocorax*
 200 *carbo*), and scoters (black scoter *Melanitta nigra*, White-winged scoter *Melanitta fusca*). The “surface
 201 feeders” were all gulls (herring gulls *Larus argentatus*, common gull *Larus canus*, lesser-backed gulls *Larus*
 202 *fuscus*, and great black-backed gulls *Larus marinus*).

203 The mean body mass of these species were derived from Hunt et al. (2005). Conversion factors of 0.3 and 0.4
204 were used to convert wet weights into dry weights and then into carbon contents, respectively (Lassalle et
205 al., 2011).

206 Daily consumption ratios were calculated according to the following empirical equation (Nilsson and Nilsson,
207 1976):

$$208 \quad \text{Log}(R_c) = -0.293 + 0.85 * \log_{10}(\text{body mass}) \quad (\text{Eq. 3})$$

209 This value was then multiplied by 365 days and divided by the mean weight of the taxon to provide annual
210 Q/B ratio in year⁻¹. The P/B ratio for the two functional groups was based on estimates published in Nelson
211 (1979). For these two groups, the diet compositions were retrieved from literature (Hunt et al., 2005). The
212 proportion of prey captured outside the area was considered as imports in their diet (see Table 2 in Appendix
213 A).

214 2.4.2 Marine mammals

215 Abundance data for bottlenose dolphins (*Tursiops truncatus*) and harbour porpoises (*Phocoena phocoena*)
216 were collected from aerial surveys from November 2011 to August 2012 (Martinez et al., 2014). Abundance
217 for harbour seals (*Phoca vitulina*) and grey seals (*Halichoerus grypus*) were derived from telemetric surveys
218 from 2007 to 2013 (Martinez et al., 2014).

219 For each species, the mean body weight was calculated according to its maximum body length (Trites and
220 Pauly, 1998). To convert wet weights into carbon contents, a conversion factor of 0.1 was used (Bradford
221 Grieve et al., 2003). To estimate the Q/B ratio, we used the metabolic rates and the daily consumption
222 according to the empirical equations of Boyd (2002) and Spitz et al. (2010). The P/B ratios for these four
223 species were taken from Christensen et al. (2009). Their diet compositions were defined according to Spitz
224 et al. (2006). Based on the aerial surveys, marine mammal distributions cover large spatial scales far beyond
225 the Bay of Seine limits. Consequently, the proportion of prey captured outside the area was considered as
226 imports in their diet (see Table 2 in Appendix A).

227 2.4.3 Fish compartments

228 Abundance data for fish were collected from the GOV ("Grande Ouverture Verticale"= high opening) bottom-
229 trawl survey conducted annually in October by IFREMER in the eastern English Channel and the south of the
230 North Sea since 1988 (Channel Ground Fish Survey, CGFS). Data were averaged over 3 years (from 2010 to
231 2013). Fish were grouped into 6 functional groups: sharks and rays, gurnards, piscivorous, planktivorous,

232 benthos feeders, and other flatfish. Moreover, mackerel (*Scomber scombrus*), European sea bass
233 (*Dicentrarchus labrax*), Atlantic cod (*Gadus morhua*), whiting (*Merlangius merlangus*), Atlantic horse
234 mackerel (*Trachurus trachurus*), pouting (*Trisopterus luscus*), poor cod (*Trisopterus minutus*), European
235 pilchard (*Sardina pilchardus*), European sprat (*Sprattus sprattus*) sea bream (*Spondyliosoma cantharus*),
236 common sole (*Solea solea*), and European plaice (*Pleuronectes platessa*) formed 12 single-species
237 compartments. These 12 species are either commercial species or species known to be attracted by the reef
238 effect. Therefore, they were not aggregated with the other compartments in order to see more in details the
239 potential impact of the MRE.

240 Fish wet body weights (originally in kg km⁻²) were converted to carbon contents using a conversion factor of
241 0.11 (Oguz et al., 2008). Q/B and P/B ratios were taken from Mackinson and Daskalov (2007). The diet
242 compositions were retrieved from the literature (Cachera 2013). Landings data were obtained from the
243 Fisheries Information System of IFREMER (<http://sih.ifremer.fr/>).

244 2.4.5 Invertebrate compartments

245 *Cephalopods*

246 Abundance data (in kg.km⁻²) for cephalopods were also collected from the GOV bottom-trawl survey CGFS
247 and averaged over 3 years (from 2010 to 2013). Cephalopods were divided into 2 groups: “Bentho-pelagic
248 cephalopods” composed of *Loligo* sp. and *Allotheuthis* sp., and “Benthic cephalopods” composed of *Sepia*
249 *officinalis*., Conversion factors of 0.192 and 0.402 were used to convert wet weights into dry weights and
250 then into carbon contents, respectively (Brey et al., 2010). Q/B and P/B ratios were taken from Sanchez and
251 Olaso (2004). Landings data were taken from the Fisheries Information System of IFREMER
252 (<http://sih.ifremer.fr/>). Diet compositions were retrieved from the literature (De Pierrepont et al., 2005; Daly
253 et al., 2001).

254

255 *Benthic invertebrates*

256 Benthic invertebrates were sampled with a 0.1 m² Day grab in June 2009. Species were grouped into 4
257 compartments: “predators”, “filter feeders”, “bivalves” and “deposit feeders”. Bivalves were not aggregated
258 with the filter feeders to investigate in more details their importance in the functioning of the trophic web
259 as well as to test the hypothesis of Norling and Kaustky (2008). In addition the above 4 groups, king scallop
260 (*Pecten maximus*) was included as a single-species compartment given its economic value. Ash-free dry
261 weights were converted to carbon contents using a conversion factor of 0.518 (Salonen et al., 1976 in Brey,
262 2001). P/B and Q/B were taken from Le Loc’h (2004) and Brey (2001), and diet compositions were taken from
263 Rybarczyk and Elkaim (2003).

264 *Suprabenthos*

265 The suprabenthos is defined as living organisms in the water layer immediately adjacent to the bottom that
266 make daily vertical migrations and / or seasonal movements at varying distances from the bottom (Brunel et
267 al., 1978) (e.g. gammarids, corophium). Abundance data were collected from Vallet (1997) that studied
268 suprabenthos all across the English Channel. P/B and Q/B ratios were taken from Brey (2001) and Le Loc'h
269 (2004), and the diet composition was obtained from Lobry et al. (2008). Ash-free dry weights were converted
270 to carbon contents using a conversion factor of 0.518 (Salonen et al., 1976 in Brey 2001).

271 *Meiofauna*

272 The values of mean annual biomass of meiofauna, the P/B ratio and Q/B were obtained from the literature
273 (Ratsimbazafy, 1998; Chardy and Dauvin, 1992; Le Loc'h, 2004).

274 *2.4.6 Zooplankton*

275 Mean annual biomasses of zooplankton were collected from the Seine Aval I programme. P/B and P/C ratios
276 were obtained from another study focused on the Eastern part of the Bay of Seine (Rybarczyk and Elkaim,
277 2003).

278
279 *2.4.7 Bacteria*

280 The benthic bacterial biomass, P/B, and Q/B ratios were taken from Chardy (1987), McIntyre (1978), and
281 Mackinson and Daskalov (2007), respectively.

282 *2.4.8 Phytoplankton*

283 The phytoplankton biomass and P/B ratio were taken from data collected in the Bay of Seine by Baehr et al.
284 (2014) and Souissi (2007).

285 *2.4.9 Detritus*

286 The mean annual biomass of dead organic matter was obtained from a study focused on the Eastern part of
287 the Bay of Seine (Tecchio et al., 2015).

288
289 **2.5 Balancing the Ecopath model**

290 To obtain a mass-balanced model, inputs (i.e. B, P/B, Q/B, EE, and diets) were slightly and manually modified
291 to satisfy the constraint of Ecotrophic Efficiency lower than 1. We also checked that physiological rates were
292 within the known limits for each functional group: (i) P/Q of 0.1–0.3 for consumers, and (ii)
293 respiration/biomass (R/B) ratios of 1–10 for fish groups. Biomass accumulation and net migration were both
294 set to zero. The EwE pedigree routine was used to quantify the input parameter uncertainties (Christensen

295 and Walters, 2004). It helped to identify the least certain parameters that should be modified first to achieve
296 mass balance. The balancing approach that we used was top-down, starting with the top predator groups
297 and moving down the food web to balance inconsistencies. When modifications of the data had to be
298 performed, diet compositions (DC) were modified first, and then ratios of P/B and Q/B. Biomasses (B) were
299 considered as less uncertain, and thus were modified the last during the balancing process.

300
301 Biomasses of the small pelagic fish and flatfish were left to be estimated by the model after setting their
302 Ecotrophic Efficiency to 0.99 given their high exploitation rate. The estimated biomasses were higher than
303 the input data first entered during model construction for those two groups. This can be partly explained by
304 the fact that the GOV bottom-trawl deployed during the Channel Ground Fish Survey by IFREMER is not fully
305 adapted to capture these species, the abundance of which is thus likely to be underestimated. In the same
306 way, the deposit feeders and suprabenthos biomasses were also left to be estimated by the model assuming
307 an Ecotrophic Efficiency to 0.99.

308 **2.6 Simulating the “reef effect” due to the wind farm implantation using Ecosim simulations**

309 The Ecosim module was used to analyse the potential impacts of biomass accumulation on hard substrates
310 represented by the wind turbines and the scour protections on the structure and functioning of the local
311 trophic web during the operational phase. The dynamic routine of the EwE package, Ecosim allows to
312 describe temporal changes of the system variables (biomass, fishing, predation) starting from the initial
313 Ecopath model (Walters et al., 1997; Christensen and Walters, 2004). The Ecosim equation that models the
314 biomass growth rate for each group (i) is:

$$315 \quad \frac{dB_i}{dt} = g_i \sum_j Q_{ji} - \sum_j Q_{ij} + I_i - (M_i + F_i + E_i)B_i \quad (\text{Eq. 4})$$

316 Where I_i and E_i are the immigration and emigration rates, M_i is the natural mortality, and F_i is the fishing
317 mortality (Walters et al., 1997, Christensen and Walters 2004). Calculations of the consumption rates (Q_{ij})
318 are based upon the ‘foraging arena’ theory, in which the biomass of i is divided between available prey
319 (vulnerable fraction, V_i) and unavailable prey (non-vulnerable fraction, $B_i - V_i$). A low value of vulnerability
320 will indicate a ‘bottom-up’ controlled interaction, while a high value of vulnerability will indicate that
321 mortality of the prey is controlled by the predator biomass, as in a ‘top-down’ control (Ahrens et al., 2012).

322 Ecosim was used to build another Ecopath solution, derived from the initial Ecopath model described above.
323 Biomasses of species that would presumably profit from the “reef effect” such as benthic invertebrates (filter
324 feeders, bivalves, and predators), benthos feeders fishes, whiting, pouting, Atlantic cod, other flatfish, sole

325 and surface feeders seabirds, were modelled based on data from the literature (Koller et al., 2006; Reubens
326 et al., 2011; Lindebon et al., 2011, Krone et al., 2013a; Krone et al., 2013b; Reubens et al., 2013). These
327 changes in biomass were the main variations taken into account to drive the evolution of the system through
328 time. Species biomasses on the turbine foundations and scour protections were calculated by multiplying the
329 average biomass per m² found in the literature by the surface area represented by the turbine foundations
330 and scour protections and divided by the total wind farm area at Courseulles-sur-mer. Then, the estimated
331 increase was added to the basal biomass for each functional group susceptible to profit from the implantation
332 of the wind farm in 2018. Forcing time series over a period of 30 years were as such established for the
333 biomass of the following groups: benthic invertebrates (filter feeders, bivalves, and predators), benthos
334 feeders fish, whiting, pouting, Atlantic cod, other flatfish, sole, surface feeders seabirds. These forcing time
335 series were responsible for a disruptive change in the biomass of the species cited above. Ecosim model were
336 run with the new biomass values for the targeted groups listed above and the original biomass values for the
337 other functional groups in the model. In this scenario, the biomass of groups that could presumably profit
338 from a reef effect were simultaneously increased and vulnerability was set to 2 for all groups. In this scenario,
339 we chose to take into account all the effects (direct and indirect), not only those directly propagating from
340 prey-predator interactions. The biomass and production of the phytoplankton was blocked at the initial
341 value. All other parameters and ratios remained unchanged. Then, a new Ecopath model was extracted at
342 the end of the 30 years simulation to compare the situation before (BOWF (Before Offshore Wind Farm)
343 model described above) and after the construction of the offshore wind farms (REEF scenario).

344 To test the robustness of our working hypotheses, four sensitivity analyses were also performed to analyse
345 effects of fish and benthic aggregation on the trophic web functioning, inside an OWF. The methods included:
346 (1) forcing biomass dynamics of only the bivalves and filters feeders compartments through time (forcing
347 biomass); (2) starting to increase the biomass of benthic organisms and then one year later increase the
348 biomass of fish that would presumably profit from the reef effect in order to take into account the different
349 species time span (time lag); (3) and (4) changes in the vulnerability of the bivalve group. Vulnerability
350 indicates the degree to which an increase in predator biomass will cause mortality for a prey (Christensen et
351 al., 2008). In these two additional scenarios, we increased the vulnerability of bivalves to 5 and 10
352 respectively. These sensitivity analyses are presented in the Supplementary Material Appendix B.

353 **2.7 Analysing ecosystem organisation, major interactions and emergent properties**

354 For the two Ecopath models (BOWF model and REEF scenario), the trophic level of each functional group was
355 calculated from its diet composition matrix. It is computed as the weighted average of the trophic levels of
356 its prey, when primary producers and non-living material are set at a trophic level of 1:

357
$$TL_j = 1 + \sum_{i=1}^N DC_{ji} TL_j \quad (\text{Eq. 5})$$

358 where DC_{ji} is the fraction of the prey i in the diet of the predator j .

359 Ecological Network Analysis (ENA) indices were calculated using the network analysis plug-in included in *EwE*
360 (Christensen and Walters, 2004). The following ENA indices were retained:

- 361 • Total System Throughflow (TST $\text{gC m}^{-2} \text{year}^{-1}$) was calculated as the sum of the flow balance (inflow =
362 outflow) of all compartments (Latham, 2006).
- 363 • The Total System Throughput (T., $\text{gC m}^{-2} \text{year}^{-1}$) was calculated as the sum of all the flows in the food web,
364 characterising its overall activity and size (Latham, 2006).
- 365 • The Omnivory Index (OI) represents the trophic specialisation of the predator, assuming values close to
366 zero when the consumer is fully specialized, feeding on a single trophic level, and higher values when the
367 predator feeds on several trophic levels (Pauly et al., 1993).
- 368 • The System Omnivory Index (SOI) was calculated as the average of the OIs of the individual group,
369 weighted by the logarithm of each consumer intake (Pauly et al., 1993; Christensen and Walters, 2004). It
370 is both a measure of the predators trophic specialisation in terms of trophic levels and an indicator of the
371 structure and complexity of a trophic network, assuming that high values of SOI correspond to a web-like
372 structure and low values of SOI to a chain-like structure (Libralato, 2008). For instance, marine ecosystems
373 of the northern Europe have a SOI ranging from 0.14 to 0.36 (Mackinson and Daskalov, 2007).
- 374 • The Finn's Cycling Index (FCI) gives the percentage of all flows generated by cycling (i.e. the percentage of
375 carbon flowing in circular pathways) (Finn, 1980).
- 376 • The Ascendency (A) is a measure of the system activity (Total System Throughput) linked to its degree
377 of organization (Average Mutual Information; AMI) (Ortiz and Wolff, 2002). This index was related to
378 the developmental status or maturity of an ecosystem (Ulanowicz, 1986).
 - 379 • The Transfer Efficiency (TE) is the fraction of total flows of each discrete trophic level that
380 throughputs into the next one (Lindeman, 1942). The "Lindeman spine plot" is a representation of
381 trophic transfers into a linear food chain. It includes the fraction of the biomass directed to detritus
382 by each discrete trophic level ('flow to detritus') and the transfer efficiency from one level to the next
383 one (TE).

384 The Mixed Trophic Impact (MTI) routine was applied to evaluate the impacts of direct and indirect
385 interactions in the food web. This analysis shows the theoretical impact that a slight increase in the biomass
386 of one group would have on the biomasses of all the other groups in the system (Ulanowicz and Puccia, 1990).

387 Although this is a static analysis that does not account for temporal scale changes, the MTI can be used as a
388 sensitivity analysis to explore possible impacts of moderate biomass variations. The Keystoneness Index was
389 calculated for each functional group, to identify which groups possess a high overall effect on the other
390 groups compared to their relatively low biomass. Calculations were made according to the index defined by
391 Libralato et al. (2006). This analysis uses the MTI matrix to calculate an index summarising the impact that a
392 minimal variation of biomass of a particular group would have on the biomasses of the other groups in the
393 system. The Detritivory/Herbivory ratio (D/H) is the ratio between values of detritivory flows (from detritus
394 to trophic level II) and herbivory flows (from primary producers to trophic level II) (Ulanowicz, 1992). The
395 proportion between biomass of fish groups and biomass of invertebrate groups was also calculated.

396 **3. RESULTS**

397 An Ecopath model (BOWF model) of the area was constructed using data from local sampling surveys or from
398 similar ecosystems. Another Ecopath model (REEF scenario) was derived after simulating 30 years of dynamic
399 evolution of the area following the construction of an offshore wind farm and the increase in hard substrates
400 causing a reef effect (i.e. aggregation of biomass).

401

402 **3.1 Compartments' ecological roles before the installation of the offshore wind farm**

403 The overall pedigree index value calculated for the BOWF model before the implantation of the offshore
404 wind farm was 0.523.

405 The functional group dominating biomass was “bivalves” (mostly composed of the clam *Polititapes*
406 *rhomboides*), which represented 42% of the total living biomass of the system (Table 1). The functional
407 groups contributing most to total throughflows were zooplankton, bacteria, and bivalves, with contributions
408 of 36%, 15%, and 8%, respectively.

409 The Trophic Level of functional groups ranged from TL=1 for primary producers and detritus, as imposed by
410 construction, to a maximum of 4.8 for grey seals in the BOWF model (see Table 1 in Appendix A). Other
411 marine mammals (i.e. bottlenose dolphins, harbour porpoises and harbour seals) ranked just below as top
412 predators in the trophic webs. The omnivory of the functional groups, estimated by the omnivory index (OI),
413 was low overall (0.001–0.474), except for Surface-feeding seabirds (OI=0.757) (see Table 1 in Appendix A).
414 These low values indicate a general dietary specialisation of the fauna, each functional group feeding on a
415 narrow range of trophic levels.

416 The MTI analysis highlighted that benthic invertebrate predators negatively affected benthic invertebrate
417 filter feeders, bivalves, deposit feeders, suprabenthos and meiofauna (Fig. 3). Other predators (such as sea

418 bream or flafish), also feeding on those benthic invertebrates and thus considered as competitors, responded
419 negatively to an increase of benthic invertebrate predators' biomass. In fact, functional groups benefiting
420 from an increase in benthic organisms' biomass (predators, filter feeders and bivalves) were some fish species
421 (i.e. flat fish and sea bream), marine mammals and seabirds. Pouting exerted a widespread influence over
422 the trophic web, due to its wide diversity of prey items (benthic invertebrate deposit feeders, filters feeders,
423 and predators, pilchard, sprat, and planktivorous fish).

424 <Figure 3>

425 The keystone index was highest for pouting (0.095) and for benthic invertebrate predators (0.059), which
426 also presented the maximum values of relative total impact (Fig. 4; see Table 1 in Appendix A). Another group
427 with relatively high keystone index and low biomass was the harbor porpoise.

428 <Figure 4>

429 **3.2 Ecosystem structural features after the installation of the wind farm**

430 Based on the simulation of the wind farm presence, REEF scenario, Ecosim generated a variation in biomass
431 of the functional groups for which the biomass inputs were not set a priori.

432 An increase in substrates available for epibenthic sessile organisms and fish after the wind farm construction
433 implied an increase of the total system biomass by 40%.

434 First, for those functional groups for which we calculated an accumulation of biomass on new substrates, the
435 new biomass values increased by a factor of 6 for the surface feeders seabirds (dominated by *Larus* sp.), 3.5
436 for the Atlantic cod, 4 for whiting, 2 for pouting, 2 for fish benthos feeders (dominated by *Callionymus* sp.),
437 2 for sole, 4 for other flatfish (dominated by *Limanda limanda*), 1.5 for benthic invertebrate predators
438 (dominated by the omnivorous species *Psammechinus miliaris*), 1.5 for filter feeders (*Balanus* sp.), and 2 for
439 bivalves (dominated by *Mytilus edulis*) (Table 1).

440 For groups whose biomass was not forced, the construction of the wind farm induced an increase in the
441 biomass of top predators, except for "diving seabirds" (Table 1). The biomass of sea bream and plaice were
442 higher in the REEF scenario than in the BOWF model (approximately 3 times higher, respectively; Table 1).

443 In contrast, Atlantic horse mackerel, poor cod, and piscivorous fish declined strongly with a 55%, 81%, and
444 97% diminution, respectively (Table 1). The biomass of benthic invertebrates, deposit feeders and
445 suprabenthos also decreased in the REEF scenario (with a decrease of 17% and 15% respectively). The ratio
446 of fish biomass over invertebrate biomass was reduced by approximately 34% between the two periods
447 (BOWF model/REEF scenario). This was related to the strong increase in benthic invertebrate biomass that
448 was multiplied by approximately 2 in the REEF scenario, while fish biomass was multiplied by 1.1 only. These

449 The keystone index varied between the two periods as biomasses changed (Fig. 4; see Table 1 in
450 Appendix A). Pouting was the functional group with the highest keystone index in the two scenarios. In
451 the BOWF model, benthic invertebrate predators occupied the second place followed by harbor porpoise
452 whereas in the REEF scenario, zooplankton occupied the second place and was followed by benthic
453 invertebrate predators.

454 The total ecosystem activity (T.), representing the sum of all flows in the system, increased between the two
455 periods by approximately 13.96% (Table 2). The System Omnivory index (SOI) of the 2 trophic webs increased
456 by 15.03% (from 0.173 to 0.199) between the two periods. This increase should be related to the variations
457 of pouting omnivory (i.e. increased by a factor of 3). The Finn's Cycling Index (FCI) increased by 40% between
458 the two scenarios (Table 2). This result is in line with the increase of detritivory (mainly due to benthic
459 invertebrate predators and filter feeders), which doubled. The ascendancy (A) increased by 15% (Table 2).
460 The transfer efficiencies (TE) showed a similar pattern in between the two periods, decreasing with TL in the
461 2 models (Fig. 5). However, values were slightly lower in the REEF scenario.

462 <Figure 5>

463 The comparison of compartment throughflows before and after the construction of the offshore wind farm
464 showed that activity of top predators, except for "diving seabirds", increased after the construction. The
465 compartments sharks and rays, Atlantic cod, whiting, pouting, European sprat and sea bream strongly
466 increased their activity after the construction as well (Fig.6). A similar pattern was observed with all flat fish
467 groups (i.e. sole, plaice, and other flatfish). Activity strongly increased after the construction in some benthic
468 groups, namely invertebrate predators, filter feeders and bivalves. In contrast, other benthic groups such as
469 king scallop, deposit feeders and suprabenthos, reduced their overall activity once the offshore wind farm
470 was built.

471 <Figure 6>

472 The system overall EE (the percentage of production consumed by predators including fishing activities)
473 increased by 5% between the two periods. For instance, the phytoplankton biomass and P/B remained
474 unchanged in the REEF scenario but its EE increased by 32%. The biomasses and consumptions exerted by
475 bivalves and benthic invertebrates filter feeders were higher in the REEF scenario than in the BOWF model;
476 consuming/grazing more phytoplankton (e.g. until 4 times higher for filter feeders; Table 1). The EE of these
477 species were also higher in the REEF scenario due to the fact that they were more consumed by fish such as
478 cod, pouting and sea bream. The EE of these fish species were also higher as they were more consumed by
479 marine mammals. For instance, Atlantic cod was consumed approximately 5 and 3.5 times more by cetaceans
480 and seals, respectively, after the wind farm implantation. Again, after the construction, the consumption of
481 detritus in the system increased by 68.5%.

482 In terms of flow analysis, the detritivory/herbivory ratio (D/H) increased by 18.8% between the two periods.
483 The detritivory was multiplied by 1.5 and the herbivory was multiplied by 1.2 between the two situations.

484 **3.3 Sensitivity analyses**

485 The results of the four scenarios (presented in the Supplementary material, Appendix B) highlight that the
486 choices made in the “REEF” scenario were robust as they show that even considering a possible range of
487 variability, we obtained the same main results.

488 For instance, for groups without forced biomass at the start of the simulation, the construction of the wind
489 farm induced an increase in biomass, especially for top predators, in the four additional scenarios (Table 1,
490 in Supplementary Material, Appendix B). For instance, the biomass of sea bream after 30 years of simulations
491 were higher in the four scenarios than in the “BOWF” Ecopath model (approximately 3 times higher in the
492 “REEF Filter Feeders” and “time lag” scenarios and approximately 4 times higher in the “REEF Bivalve V5” and
493 “V10” (Table 1, in Supplementary material, Appendix B)). On the same line, the biomass of plaice was higher
494 in the four scenarios compared to the BOWF Ecopath model (approximately 3 times higher). This generalized
495 increase in apex predators was congruent with the one highlighted under the “REEF” scenario. However, in
496 the “REEF Filter feeders”, the biomass of predatory fish (cod, whiting) resulting from this simulation
497 increased, but this increase was inferior to the input that we originally entered for the “REEF scenario”. The
498 difference can be explained because EwE takes into account only prey-predator interactions and does not
499 take into account other indirect effects such as the reserve effect that exist in the park where biomass
500 sampling was performed.

501 In terms of flow analysis, we observed an increase in the Detritivory/Herbivory ratio (D/H) between the BOWF
502 model and the different scenarios (Table 2, in Supplementary Material, Appendix B). For instance, the D/H

503 increased by 11%, 17%, 20% in the “REEF filter feeders”, “REEF time lag”, “Reef mussel V5”, “Reef mussel
504 V10”, respectively (Table 2, in Supplementary Material, Appendix B). Other ENA indices remained mostly
505 unchanged under the different scenarios. Again, this change in D/H was in accordance with the conclusion
506 drawn from the “Standard REEF” scenario.

507 **4. Discussion**

508 **4.1 Food web control before the installation of the offshore wind farm**

509 From a methodological point of view, the high value of the pedigree index indicated that the input data used
510 in the reference Ecopath model (BOWF model) were of good quality when compared to the distribution of
511 pedigree values for pre-existing models (Morissette, 2007). In fact, the pedigree index (0.523) was in the
512 highest part of the range (0.164 to 0.676) reported in Morissette (2007). Indeed, biomass data were mainly
513 obtained from local, highly replicated, and detailed samplings and the diet compositions of the main fish
514 species came from stomach content studies performed in the eastern English Channel.

515 The Courseulles-sur-mer food web appeared to be mostly controlled by intermediate trophic levels. First, the
516 MTI analysis revealed that benthic invertebrate predators and pouting, which occupied an intermediate
517 trophic level (TL= 3 and TL=3.7 respectively), had a strong impact on numerous groups of both higher and
518 lower trophic levels in the system. For instance, pouting supported a high diversity of predators (i.e. marine
519 mammals, cephalopods, elasmobranch and teleosts) and fed mainly on benthic invertebrate predators (i.e.
520 crustaceans), filter feeders, and suprabenthos. This result concurred with the high ranking of pouting in the
521 keystone index (classification see Table 1 in Appendix A). A keystone group is defined as a group having
522 a high structuring impact on the other groups, despite a relatively low biomass (Power et al., 1996). Since
523 pouting biomass was high (i.e. 3.85 gC m⁻² year⁻¹), this group was likely to be a key structuring group in the
524 system rather than a keystone group *sensu* Power et al. (1996). These results suggest a possible “wasp-waist”
525 control of the system by intermediate trophic levels (Cury et al., 2000). In “wasp-waist” systems, the flow of
526 energy is controlled by the mid-trophic levels rather than the bottom or top organisms. The mid-trophic levels
527 exert top-down control on zooplankton and benthic groups, and bottom-up control on top predators (Cury
528 et al., 2000). This type of control has generally been demonstrated to be the norm for small plankton-feeding
529 pelagic species, such as anchovies and sardines, in upwelling pelagic ecosystems around the world (Cury et
530 al., 2000, 2004; Coll et al 2006; Bakun, 2006). The role played here by pouting, a demersal species, was hence
531 an original feature of the Courseulles-sur-mer food web. Pouting could then be considered as a benthic
532 equivalent of sardines but with a higher position in the food web compared to examples involving small
533 pelagics. However, these results are only based on the MTI and Keystone analysis that are interrelated
534 and must be taken with caution.

535 **4.2 Potential impacts of the reef effect inside the offshore wind farm on the trophic web**
536 **functioning**

537 As the results show that even considering a possible range of variability through the 4 variants of the “REEF”
538 scenario, we obtained the same main results, we choose to discuss only the results of the “REEF” scenario
539 (Supplementary Material, Appendix B).

540 The construction of the Courseulles-sur-mer offshore wind farm was suspected to increase detritivory in the
541 food web. As expected, the D/H ratio changed positively between the two periods, underlying the importance
542 of the trophic interactions involved in the detrital chain (Dame and Christian, 2007). This was related to the
543 higher consumption of detritus by benthic organisms and might confirm the hypothesis of Norling and
544 Kautsky (2007, 2008) by which blue mussels expansion could be responsible for a shift from primary
545 producers and grazers dominated food chains towards a more detritus-feeding community. Sessile
546 organisms, such as blue mussels colonizing the 75 turbines, are indeed expected to enhance the benthic
547 production of food for fish and benthic organisms through the deposition of organic matter such as feces and
548 dead organisms (Wilhelmsson et al., 2006; Maar et al., 2009). Wind turbines and scour protections were
549 identified as offering particularly favorable substrates and feeding conditions for blue mussels in field studies
550 (Wilhelmsson, et al., 2006; Wilhelmsson and Malm, 2008; Maar et al., 2009; Krone et al., 2013). Bivalves can
551 form dense belts and, in some cases, account for almost 97% of the total epibenthic biomass on foundations
552 (Maar et al., 2009). According to Maar et al. (2009), wind turbines can support a mussel biomass ten times
553 higher per unit area than the one observed on bridge pillings in the same region, and the growth of blue
554 mussels on turbines can also double the biomass of filter feeders in a wind farm area as a whole compared
555 to the situation before its construction. Another potential effect suggested in the litterature is an input of
556 organic material from fish and crustaceans closely associated with the turbines as well as an entrapment of
557 organic material by the turbines themselves, contributing to an enrichment of the seabed and enhancing the
558 abundance of deposit-feeding organisms and their predators (Maar et al., 2009; Wilhelmsson et al., 2010).
559 This material provided an additional source of food but, more importantly, a different “food quality” (Koller
560 et al., 2006). In soft bottom communities, filters and detritus feeders feed on small particulate matter
561 deposited on the seabed (Koller et al., 2006). Koller et al. (2006) stated that this different quality of food
562 coming from the wind turbines was responsible for a “shortcut within the food web” because this resource
563 was consumed by larger predators and scavengers. Other effects suggested in the literature, but that could
564 not be demonstrated here as our flows were only in carbon currency, are that the increase in filter feeders
565 biomass, and more particularly in blue mussels, could imply an increased excretion of ammonium and thus a
566 clearer water (reduction of water turbidity), which in turn could lead to an increase in growth rates of
567 phytoplankton and filamentous algae (Kautsky and Evans, 1987; Prins and Smaal, 1994; Norling and Kautsky,
568 2008).

569 The introduction of turbines with their associated scour protections generated an additional source of food
570 in the ecosystem. Habitats created by the monopile foundations and the fauna they harbour were

571 responsible for an increase in the system total biomass. Possibly due to the biomass modifications, EE values
572 (the percentage of production consumed by predators) of the whole ecosystem showed an increase of 5%.
573 This result can be explained by the increase in predation exerted by the species attracted by the reef effect.
574 For instance, our model showed that the benthic invertebrates colonising the monopile foundations served
575 in turn as food resources for other species such as poutings and sea breams. The related increases in pouting,
576 cod and sea bream biomass was *in fine* beneficial to their predators, notably marine mammals. These results
577 confirm the hypothesis enounced in the introduction of this study that the benthic biomass increase acts as
578 an additional prey resource for higher trophic levels up to apex predators (Lindeboom et al., 2011; Scheidat
579 et al., 2011; Russell et al., 2014). This result was also in line with the stomach content analyses of Reubens et
580 al. (2011), who demonstrated that pouting fed on the macrobenthos produced on the Thornton bank wind
581 turbines in the Belgian part of the North Sea. For instance, the amphipode, *Jassa herdmani*, presented a
582 numerical abundance index of 84.6% and it was the most important prey species of the pouting dietary
583 composition (Reubens et al., 2011). Moreover, it could be assumed that seabirds strongly profit from
584 additional biomass of epifaunal bivalves on the 75 turbines as they would become easily available. These
585 basic parameters estimates analysis was to some point consistent with the relatively low values of SOI
586 indicating a chain-like structure both before and after the installation of the offshore wind farm.

587 According to our model, the “reef effect” generated by the construction of the Courseulles-sur-mer offshore
588 wind farm was predicted to have a relatively limited impact on the structure and flow pattern of the local
589 food web. The comparison of the ENA indices (total ecosystem activity (T.), system omnivory index (SOI),
590 ascendancy (A) and keystoneess) between the BOWF model and the REEF scenario showed small variations
591 between the two periods. Furthermore, the transfer efficiencies (TE) decreased parallely with TL in the 2
592 models indicating that the compartments, although exposed to an increase in biomass of some specific
593 groups, behaved functionally in a similar way under the two scenarios. Ecopath is a single solution model and
594 so direct statistical comparisons were not possible. As network indices of Ascendancy are scaled according
595 to log values of combinations of flows, small changes expressed in percentages could reflect much larger
596 disparities, and hence larger ecological changes (Ulanowicz 1986; Baird & Ulanowicz 1993). In addition, the
597 ENA results from the BOWF model and the REEF scenario can be compared with other ecosystems studied
598 with the same methodology (Ecopath) and located in the same biome such as the Bay of Somme (Rybarczyk
599 et al., 2003), the Dublin Bay (Wilson and Parkes, 1998), and the Seine Estuary (Tecchio et al., 2015). Values
600 of ENA indices in both situations for the Courseulles-sur-mer area remained in the range delimited by these
601 similar ecosystems, suggesting no major trophic structural and functional shift due to the installation of an
602 offshore wind farm (Table 2).

603 <Table 2>

604 **4.3 Advantages and limitations of the EwE models**

605 Conceptually, the main asset of this study was to lay the foundations defining an ecosystem-based approach
606 to marine renewable energy management, in line with what has been done during the last 20 years in the
607 Ecosystem Approach to Fisheries (Garcia et al., 2003). Previous studies have largely focused on the
608 conservation of some groups of valuable species and their habitats only. The proposed model considered the
609 full range of size classes of biota, from prokaryotes to apex predators, for a representative site of the eastern
610 Bay of Seine basin: the Courseulles-sur-mer offshore future wind farm. The approach for this specific site can
611 then be transposed to other wind farm projects in the English Channel and broadly to other shallow and
612 macrotidal seas of temperate latitudes. Applying this modelling method can enrich the field of environmental
613 impact studies on future offshore wind farms and, more generally, on marine renewable energy sites.

614 Models for offshore wind farms are by definition atypical due to their intrinsic small spatial scale (here, 50
615 km²) with one on the main drawbacks being the fact that the population dynamics and home range of mobile
616 species vastly exceed the limits of wind farm sites. Here, as a partial solution, we considered trophic transfers
617 outside the area of the Courseulles-sur-mer offshore wind farm for marine mammals and seabirds by setting
618 imports in the diet composition matrix. This limitation is common to all Ecopath small-scale models (e.g.
619 marine protected areas (Albouy et al., 2010; Colléter et al., 2012; Valls et al., 2012). Regarding community
620 changes, our choice here was to use estimates derived from the literature and expert knowledge and not
621 from complex models. This option was relevant here as a lot of information coming from the offshore wind
622 farms already in exploitation could be extracted and helped formulating meaningful hypotheses. Another
623 possibility would have been to use these data for calibrating a community model predicting the changes in
624 existing species and at the same time the arrival of new species around the turbines. Finally, the BOWF model
625 and REEF scenario could not simulate all possible impacts generated by the increased biomass of mussels on
626 biogeochemical process such as the excretion of ammonium as our model is based only on carbon flows.

627 **5. Conclusions**

628 This ecosystem-based approach of offshore wind farm impacts showed 1) an original control of the
629 Courseulles-sur-mer site food web by putting at the intermediate trophic levels, indicating a potentially
630 “wasp-waist” controlled food web, 2) that the anticipated increase of mussel biomass after the offshore wind
631 farm construction is predicted to lead to a food web dominated by detritivory, as hypothesized by Norling
632 and Kautsky (2008), and (3) that the anticipated increase in benthic invertebrate and benthos feeding fish
633 biomass, in response to the reef effect, is predicted to attract and benefit to apex predators, as hypothesized
634 by Lindeboom et al. (2011) and Henkel et al. (2014).

635 By combining the data collected on various ecosystem components, we determine in this study how the local
636 food web structure and function may change 30 years after the installation of the offshore wind farm. The

637 Ecopath models built in this study can then be useful to interpret how other threats, such as climate change
638 or restrictions of fisheries activities within the offshore wind farm limits, can further affect the trophic web
639 structure and functioning. This study could be considered as a first step in using food web models to assess
640 offshore wind farm impacts on the whole ecosystem.

641 **ACKNOWLEDGEMENTS**

642 This work was co-funded by the Normandy Region and by the group “Eoliennes Offshore du Calvados” (EOC).
643 We also acknowledge, for their help in compiling the datasets and for giving expert advices: Georges Safi
644 and Jean-Paul Robin (UMR BOREA, Caen), Alexandrine Baffreau, Sandric Lesourd and Maxime Navon (UMR
645 M2C, Caen), Ludivine Martinez, Jérôme Spitz and Charlotte Lambert (Observatoire PELAGIS, La Rochelle),
646 Francis Gohin and Maria Ching Villanueva (IFREMER, Brest), Gregory Certain (Université de Suède des
647 Sciences de l’Agriculture, Uppsala), James Jean Baptiste (Groupe Ornithologique Normand, Caen) and Nicolas
648 Bacq (Groupement d’Intérêt Public “Seine-Aval”). This work was an introduction to the project Trophik
649 (ANR/FEM EMR-ITE 2015).

650

651
652
653
654
655
656
657
658
659
660
661
662
663
664
665
666
667
668
669
670
671
672
673
674
675
676
677
678
679
680
681
682
683
684
685
686
687
688
689
690
691
692
693
694
695
696
697
698
699
700
701
702
703

Reference

Ahrens, R.N.M., Walters, C.J., Christensen, V., 2012. Foraging arena theory. *Fish Fish.* 13, 41–59. doi:10.1111/j.1467-2979.2011.00432.x

Albouy C., Mouillot D., Rocklin D., Culioli J.-M. & Le Loc'h F. 2010. Simulation of the combined effects of artisanal and recreational fisheries on a Mediterranean MPA ecosystem using a trophic model. *Mar. Ecol. Prog. Ser.* 412: 207–221

Andersson, M.H., Öhman, M.C., 2010. Fish and sessile assemblages associated with wind-turbine constructions in the Baltic Sea. *Mar. Freshw. Res.* 61, 642–650. doi:10.1071/MF09117

Baehr, A., Menet-nedelec, F., Riou, P., Fontaine, B., Francoise, S., Gangnery, A., Jacqueline, F., Lamort, L., Lesaulnier, N., Maheux, F., Picoche, C., Pierre-duplessix, O., Rabiller, E., Simon, B., 2014. Réseau Hydrologique Littoral Normand (RHLN) – Suivi 2012. Ifremer. pp.212

Bailey, H., Brookes, K.L., Thompson, P.M., 2014. Assessing environmental impacts of offshore wind farms : lessons learned and recommendations for the future. *Aquat. Biosyst.* 10, 1–13. doi:10.1186/2046-9063-10-8

Baird, D., Ulanowicz, R.E., 1993. Comparative study on the trophic structure, cycling and ecosystem properties of four tidal estuaries. *Mar. Ecol. Prog. Ser.* 99, 221–237.

Baird, D., Christian, R.R., Peterson, C.H., Johnson, G. a., 2004. Consequences of hypoxia on estuarine ecosystem function: Energy diversion from consumers to microbes. *Ecol. Appl.* 14, 805–822. doi:10.1890/02-5094

Bakun, A., 2006. Wasp-waist populations and marine ecosystem dynamics: Navigating the “predator pit” topographies. *Prog. Oceanogr.* 68, 271–288. doi:10.1016/j.pocean.2006.02.004

Bergström, L., Kautsky, L., Malm, T., Ohlsson, H., Wahlberg, M., Rosenberg, R., Capetillo, N.Å., 2012. The effects of wind power on marine life on marine life - A synthesis. REPORT 6512 October 2012.

Bergström, L., Sundqvist, F., Bergström, U., 2013. Effects of an offshore wind farm on temporal and spatial patterns in the demersal fish community. *Mar. Ecol. Prog. Ser.* 485, 199–210. doi:10.3354/meps10344

Boehlert, G.W., Gill, A.B., 2010. Environmental and ecological effects of ocean renewable energy development: a current synthesis. *Oceanography* 23, 68–81. doi:http://dx.doi.org/10.5670/oceanog.2010.46

Boyd, I.A., 2002. Energetics: consequences for fitness. In: Hoelzel, A.R. (Ed.), *Marine Mammal Biology an Evolutionary Approach*. Blackwell Science, pp.247–278.

Bradford-Grieve, J.M., Probert, P.K., Nodder, S.D., Thompson, D., Hall, J., Hanchet, S., Boyd, P., Zeldis, J., Baker, A.N., Best, H. a., Broekhuizen, N., Childerhouse, S., Clark, M., Hadfield, M., Safi, K., Wilkinson, I., 2003. Pilot trophic model for subantarctic water over the Southern Plateau, New Zealand: A low biomass, high transfer efficiency system. *J. Exp. Mar. Biol. Ecol.* 289, 223–262. doi:10.1016/S0022-0981(03)00045-5

Brey, T., Müller-Wiegmann, C., Zittier, Z.M.C., Hagen, W., 2010. Body composition in aquatic organisms — A global data bank of relationships between mass, elemental composition and energy content. *J. Sea Res.* 64, 334–340. doi:10.1016/j.seares.2010.05.002

Brey, T., 2001. Population Dynamics in Benthic Invertebrates. A Virtual Handbook. <http://thomas-brey.de/science/virtualhandbook>.

Brunel, P., Besner, M., Messier, D., Poirier, L., Granger, D., Weinstein, M., 1978. Le traîneau suprabenthique MACER-GIROQ : appareil amélioré pour l'échantillonnage quantitatif étagé de la petite faune nageuse au voisinage du fond. *Int. Revue. Hydrobiol.* 63, 815-829.

Cachera, M. 2013. Implications of morphological and functional traits for trophic relationships within fish communities and marine trophic network architecture. Thèse de doctorat de l'Université Sciences et Technologies de Lille, France. pp 247.

Chaalali, A., Saint-Béat, B., Lassalle, G., Le Loc'h, F., Tecchio, S., Safi, G., Savenkoff, C., Lobry, J., Niquil, N., 2015. A new modeling approach to define marine ecosystems food-web status with uncertainty assessment. *Prog. Oceanogr.* 135, 37–47. doi:10.1016/j.pocean.2015.03.012

Chardy, P., 1987. Modèle de simulation du système benthique des sédiments grossiers du golfe normand-breton (Manche). *Oceanol. Acta.* 10, 421-434.

Chardy, P., Dauvin, J.C., 1992. Carbon flows in a subtidal fine sand community from the western English Channel: a simulation analysis. *Mar. Ecol. Prog. Ser.* 81, 147-161.

- 704 Christensen, V., Walters, C.J., 2004. Ecopath with Ecosim: methods, capabilities and limitations. *Ecol. Modell.*
705 172, 109–139. doi:10.1016/j.ecolmodel.2003.09.003
- 706 Christensen, V., Walters, C.J., Pauly, D., 2005. *Ecopath with Ecosim: A User's Guide*. Fisheries Centre.
707 University of British Columbia, Vancouver, Canada, pp. 154.
- 708 Christensen, V., Walters, C.J., Pauly, D., Forrest, R., 2008. *Ecopath with Ecosim version 6 User Guide*. Lensfest
709 Ocean Futures Project 2008 1–235.
- 710 Christensen, V., Walters, C.J., Ahrens, R., Alder, J., Buszowski, J., Christensen, L.B., Cheung, W.W.L., Dunne,
711 J., Froese, R., Karpouzi, V., Kaschner, K., Kearney, K., Lai, S., Lam, V., Palomares, M.L.D., Peters-Mason,
712 A., Piroddi, C., Sarmiento, J.L., Steenbeek, Sumaila, R., Watson, R., Zeller, D., Pauly, D., 2009. Database-
713 driven models of the world's large marine ecosystems. *Ecol. Model.* 220, 1984–1996.
- 714 Coll, M., Palomera, I., Tudela, S., Sardà, F., 2006. Trophic flows, ecosystem structure and fishing impacts in
715 the South Catalan Sea, Northwestern Mediterranean. *J. Mar. Syst.* 59, 63–96.
716 doi:10.1016/j.jmarsys.2005.09.001
- 717 Colléter, M., Gascuel, D., Ecoutin, J.-M., Tito de Morais, L., 2012. Modelling trophic flows in ecosystems to
718 assess the efficiency of marine protected area (MPA), a case study on the coast of Sénégal. *Ecol. Model.*
719 232, 1–13
- 720 Cury, P., 2000. Small pelagics in upwelling systems: patterns of interaction and structural changes in “wasp-
721 waist” ecosystems. *ICES J. Mar. Sci.* 57, 603–618. doi:10.1006/jmsc.2000.0712
- 722 Daly, H.I., Pierce, G.J., Santos, M.B., Royer, J., Cho, S.K., Stowasser, G., Robin, J.P., Henderson, S.M., 2001.
723 Cephalopod consumption by trawl caught fish in Scottish and English Channel waters. *Fish. Res.* 52, 51–
724 64. doi:10.1016/S0165-7836(01)00230-2
- 725 Dame, J.K., Christian, R.R., 2007. A Statistical Test of Network Analysis: Can it Detect Differences in Food Web
726 Properties? *Ecosystems* 10, 906–923. doi:10.1007/s10021-007-9068-1
- 727 Dauvin, J.C., Lozachmeur, O., Capet, Y., Dubrulle, J.B., Ghezal, M., Mesnard, A.H., 2004. Legal tools for
728 preserving France's natural heritage through integrated coastal zone management. *Ocean Coast. Mgmt.*
729 47, 463–477.
- 730 Dauvin, J.C., Ruellet, T., Desroy, N., Janson, A.L., 2007. The ecological quality status of the Bay of Seine and
731 the Seine estuary: Use of biotic indices. *Mar. Pollut. Bull.* 55, 241–257.
732 doi:10.1016/j.marpolbul.2006.04.010
- 733 Dauvin, J.C., Ruellet, T., 2008. Macrozoobenthic biomass in the Bay of Seine (eastern English Channel). *J. Sea.*
734 *Res.* 59, 320–326. doi:10.1016/j.seares.2008.02.003
- 735 Dauvin, J.C., 2015. History of benthic research in the English Channel: from general patterns of communities
736 to habitat mosaic description. *J. Sea. Res.* 100, 32–45. Degraer, S., Brabant, R., Rumes, B., 2013.
737 Environmental impacts of offshore wind farms in the Belgian part of the North Sea: Learning from the
738 past to optimise future monitoring programmes. Royal Belgian Institute of Natural Sciences (RBINS),
739 Operational Directorate Natural Environment, Marine Ecology and Management Section: Brussels. ISBN
740 978-90-9027 pp. 928-2. 239.
- 741 De Mesel, I., Kerckhof, F., Norro, A., Rumes, B., Degraer, S., 2015. Succession and seasonal dynamics of the
742 epifauna community on offshore wind farm foundations and their role as stepping stones for non-
743 indigenous species. *Hydrobiologia* 756, 37–50. doi:10.1007/s10750-014-2157-1
- 744 De Pierrepoint, J.F., Dubois, B., Desormonts, S., Santos, M.B., Robin, J.P., 2005. Stomach contents of English
745 Channel cetaceans stranded on the coast of Normandy. *J. Mar. Biol. Assoc. UK* 85, 1539.
746 doi:10.1017/S0025315405012762
- 747 Fath, B.D., Patten, B.C., 1999. Quantifying resource homogenization using network flow analysis. *Ecol. Model.*
748 123, 193–205.
- 749 Finn, J.T. 1980. Flow analysis of models of the Hubbard Brook ecosystem. *Ecology* 61: 562–571.
- 750 Garcia, S.M.M., Zerbi, A., Aliaume, C., Do Chi, T., Lasserre, G., 2003. The ecosystem approach to fisheries. *FAO*
751 *Fish. Tech. Pap.* 443, 71. doi:10.1111/j.1467-2979.2010.00358.x
- 752 Garcia, C., Chardy, P., Dewarumez, J.M., Dauvin, J.C., 2011. Assessment of benthic ecosystem functioning
753 through trophic web modelling: the example of the eastern basin of the English Channel and the
754 Southern Bight of the North Sea. *Mar Ecol* 32 (Suppl. 1), 72–86
- 755 Gentil, F., Cabioch, L., 1997. Carte des peuplements macrobenthiques de la Baie de Seine et Manche centrale
756 sud. Carte et notice explicative de la carte. Editions de la station Biologique de Roscoff. pp. 18.

757 Goberville, E., Beaugrand, G., Sautour, B., Treguer, P., Somlit team, 2010. Climate driven changes in coastal
758 marine systems of Western Europe. *Mar. Ecol. Prog. Ser.* 408, 129-147.

759 Henkel, S.K., Suryan, R.M., Lagerquist, B.A., 2014. Marine Renewable Energy and Environmental Interactions:
760 Baseline Assessments of Seabirds, Marine Mammals, Sea Turtles and Benthic Communities on the
761 Oregon Shelf. In Shields, M.A., Payne, A.I.L. *Marine renewable energy technology and environmental
762 interactions, Humanity and the Sea.* Springer Sciences. pp. 176.

763 Heymans, J.J., Guénette, S., Christensen, V., 2007. Evaluating network analysis indicators of ecosystem status
764 in the Gulf of Alaska. *Ecosystems* 10, 488–502. doi:10.1007/s10021-007-9034-y

765 Hunt, G.L., Drew, G.S., Jahncke, J., Piatt, J.F., 2003. Prey consumption and energy transfer by marine birds in
766 the Gulf of Alaska. *Deep. Res. Part II-Topical Stud. Oceanogr.* 52, 781–797.
767 doi:10.1016/j.dsr2.2004.12.024

768 IPCC, 2014. *Climate Change 2014: Synthesis Report. Contribution of Working Groups I, II and III to the Fifth
769 Assessment Report of the Intergovernmental Panel on Climate Change* [Core Writing Team, R.K.
770 Pachauri and L.A. Meyer (eds.)]. IPCC, Geneva, Switzerland, pp. 151.

771 Kautsky, N., Evans, S., 1987. circulation of matter and nutrients in a Baltic. *Mar. Ecol. Prog. Ser.* 38, 201–212.

772 Kerckhof, F., Rumes, B., Jacques, T.J., Degraer, S., Norro, S. 2010. Early development of the subtidal marine
773 biofouling on a concrete offshore windmill foundation on the Thornton Bank (Southern North Sea): first
774 monitoring results. *J. Underw. Technol.* 29: 137–149. doi:10.3723/ut.29.137

775 Köller, J., Köppel, J., Peters, W., 2006. *Offshore Wind Energy Research on Environmental Impacts.* Springer-
776 Verlag Berlin Heidelberg. pp.371.

777 Krone, R., Gutow, L., Brey, T., Dannheim, J., Schröder, A., 2013a. Mobile demersal megafauna at artificial
778 structures in the German Bight - Likely effects of offshore wind farm development. *Estuar. Coast. Shelf
779 Sci.* 125, 1–9. doi:10.1016/j.ecss.2013.03.012

780 Krone, R., Gutow, L., Joschko, T.J., Schröder, A., 2013b. Epifauna dynamics at an offshore foundation -
781 Implications of future wind power farming in the North Sea. *Mar. Environ. Res.* 85, 1–12.
782 doi:10.1016/j.marenvres.2012.12.004

783 Langhamer, O., 2012. *Artificial Reef Effect in relation to Offshore Renewable Energy Conversion: State of the
784 Art.* *Sci. World J.* 2012, 8. doi:10.1100/2012/386713

785 Lassalle, G., Lobry, J., Le Loc'h, F., Bustamante, P., Certain, G., Delmas, D., Dupuy, C., Hily, C., Labry, C., Le
786 Pape, O., Marquis, E., Petitgas, P., Pusineri, C., Ridoux, V., Spitz, J., Niquil, N., 2011. Lower trophic levels
787 and detrital biomass control the Bay of Biscay continental shelf food web: Implications for ecosystem
788 management. *Prog. Oceanogr.* 91, 561–575. doi:10.1016/j.pocean.2011.09.002

789 Latham, L.G., 2006. Network flow analysis algorithms. *Ecol. Model.* 192, 586–600.

790 Leitão, F., 2013. *Artificial Reefs : From Ecological Processes To Fishing Enhancement Tools.* *Brazilian J.
791 Oceanogr.* 61, 77–81. doi:10.1590/S1679-87592013000100009

792 Le Loc'h, F., 2004. *Structure, fonctionnement, évolution des communautés benthiques des fonds meubles
793 exploités du plateau continental Nord Gascogne.* Thèse de Doctorat, Université de Bretagne
794 Occidentale, Océanographie Biologique, Brest, France. pp. 379.

795 Leonhard, S., Stenberg, C., Støttrup, J., 2011. Effect of the Horns Rev 1 Offshore Wind Farm on Fish
796 Communities Follow-up Seven Years after Construction. *DTU Aqua Rep.* pp. 99.

797 Libralato, S., 2008. System Omnivory Index. *Ecol. Indic.* 4, 3472–3477.

798 Libralato, S., Christensen, V., Pauly, D., 2006. A method for identifying keystone species in food web models.
799 *Ecol. Modell.* 195, 153–171. doi:10.1016/j.ecolmodel.2005.11.029

800 Lindeboom, H.J., Kouwenhoven, H.J., Bergman, M.J.N., Bouma, S., Bresseur, S., Daan, R., Fijn, R.C., de Haan,
801 D., Dirksen, S., van Hal, R., Hille Ris Lambers, R., ter Hofstede, R., Krijgsveld, K.L., Leopold, M., Scheidat,
802 M., 2011. Short-term ecological effects of an offshore wind farm in the Dutch coastal zone; a
803 compilation. *Environ. Res. Lett.* 6, 035101. doi:10.1088/1748-9326/6/3/035101

804 Lindeman, R.L., 1942. The trophic dynamics aspect of ecology. *Ecology* 23, 399–418.
805 doi:10.1017/CBO9781107415324.004

806 Lobry, J., David, V., Pasquaud, S., Lepage, M., Sautour, B., Rochard, E., 2008. Diversity and stability of an
807 estuarine trophic network. *Mar. Ecol. Prog. Ser.* 358, 13–25. doi:10.3354/meps07294

808 Love, M.S., Hyland, J., Ebeling, A., Herrlinger, T., Brooks, A., Imamura, E., 1994. A Pilot Study of the
809 Distribution and Abundances of Rockfishes in Relation to Natural Environmental Factors and an

810 Offshore Oil and Gas Production Platform off the Coast of Southern California. *Bull. Mar. Sci.* 55, 1062-
811 1085.

812 Love, M.S., Caselle, J., Snook, L., 1999., Fish assemblages on mussel mounds surrounding seven oil platforms
813 in the Santa Barbara Channel and Santa Maria Basin. *Bull. Mar. Sci.* 65, 497-513.

814 Maar, M., Bolding, K., Petersen, J.K., Hansen, J.L.S., Timmermann, K., 2009. Local effects of blue mussels
815 around turbine foundations in an ecosystem model of Nysted off-shore wind farm, Denmark. *J. Sea Res.*
816 62, 159–174. doi:10.1016/j.seares.2009.01.008

817 McIntyre, A.D., 1978. The benthos of the western North Sea. *Rapp. P.-v. Réun. Cons. Int. Explor. Mer* 172,
818 405-417.

819 Mackinson, S., Daskalov, G., 2007. An ecosystem model of the North Sea to support an ecosystem approach
820 to fisheries management: description and parameterisation. *Sci. Ser. Tech. Rep. CEFAS* 142.

821 MEDDE. 2012. *Energies Marines renouvelables, études méthodologique des impacts environnementaux et*
822 *socio-économiques*. pp. 357.

823 Martinez, L., Falchetto, H., Pettex, E., Vincent, C., Peltier, H., Ridoux, V., 2014. Etude des mammifères marins
824 dans le cadre du parc éolien en mer du Calvados : Analyse des données existantes , synthèse
825 bibliographique et préconisations de suivi 122.

826 Morel, 2013. Bilan et actualisation des études ornithologiques menées entre 2008 et 2010 par le Groupe
827 ornithologique normand. *Projet de parc éolien en mer au large de Courseulles-sur-mer (Calvados)*. pp.
828 44.

829 Morissette, L., 2007. *Complexity, Cost and Quality of Ecosystem Models and Their Impact on Resilience: A*
830 *Comparative Analysis, with Emphasis on Marine Mammals and the Gulf of St. Laurence Zoology*.
831 University of British Columbia, Vancouver BC, Canada.

832 Mueller-Blenkle, C., McGregor, P.K., Gill, A.B., Andersson, M.H., Metcalfe, J., Bendall, V., Sigray, P., Wood,
833 D.T., Thomsen, F., 2010. Effects of Pile-driving Noise on the Behaviour of Marine Fish. *COWRIE Ref: Fish*
834 06-08.

835 Nelson, B., 1979. *Seabirds: their Biology and Ecology*. A&W Publishers Inc., NewYork USA.

836 Nilsson, S.G., Nilsson, I., 1976. Numbers, food consumption, and fish predation by birds in Lake Möckeln,
837 Southern Sweden. *Ornis Scand.* 7, 61-70.

838 Niquil, N., Chaumillon, E., Johnson, G. a., Bertin, X., Grami, B., David, V., Bacher, C., Asmus, H., Baird, D.,
839 Asmus, R., 2012. The effect of physical drivers on ecosystem indices derived from ecological network
840 analysis: Comparison across estuarine ecosystems. *Estuar. Coast. Shelf Sci.* 108, 132–143.
841 doi:10.1016/j.ecss.2011.12.031

842 Niquil, N., Baeta, A., Marques, J.C., Chaalali, A., Lobry, J., Patrício, J., 2014. Reaction of an estuarine food web
843 to disturbance: Lindeman’s perspective. *Mar Ecol Prog Ser.* 512, 141-154.

844 Norling, P., Kautsky, N., 2007. Structural and functional effects of *Mytilus edulis* on diversity of associated
845 species and ecosystem functioning. *Mar. Ecol. Prog. Ser.* 351, 163-175.

846 Norling, P., Kautsky, N., 2008. Patches of the mussel *Mytilus* sp. are islands of high biodiversity in subtidal
847 sediment habitats in the Baltic Sea. *Aquat. Biol.* 4, 75–87. doi:10.3354/ab00096

848 Oguz, T., Salihoglu, B., Fach, B., 2008. A coupled plankton–anchovy population dynamics model assessing
849 nonlinear controls of anchovy and gelatinous biomass in the Black Sea. *Mar. Ecol. Prog. Ser.* 369, 229–
850 256. doi:10.3354/meps07540

851 Ortiz, M., Wolff, M., 2002. Trophic models of four benthic communities in Tongoy Bay (Chile): comparative
852 analysis and preliminary assessment of management strategies. *J. Exp. Mar. Bio. Ecol.* 268, 205–235.
853 doi:10.1016/S0022-0981(01)00385-9

854 OSPAR, 2008. Background document on potential problems associated with power cables other than those
855 for oil and gas activities. *OSPAR commission*. pp. 50.

856 Patrício, J., Ulanowicz, R., Pardal, M. a., Marques, J.C., 2006. Ascendency as ecological indicator for
857 environmental quality assessment at the ecosystem level: A case study. *Hydrobiologia* 555, 19–30.
858 doi:10.1007/s10750-005-1102-8

859 Pauly, D., Soriano-Bartz, M., Palomares, M.L., 1993. Improved construction, parameterization and
860 interpretation of steady-state ecosystem models. In: Christensen, V., Pauly, D. (Eds.), *Trophic Models of*
861 *Aquatic Ecosystems*. ICLARM Conf. Proc. 26, 1–13.

862 Pearce, B., Fariñas-Franco, J.M., Wilson, C., Pitts, J., De Burg Z., Somerfield, P.J., 2014. Repeated mapping of

863 reefs constructed by *Sabellaria spinulosa* Leuckart 1849 at an offshore wind farm site. Cont. Shelf Res.
864 83,3 13.

865 Petersen, J.K., Malm, T., 2006. Offshore windmill farms: threats to or possibilities for the marine
866 environment. *Ambio*. 35, 75–80.

867 Polovina, J.J., 1984. Model of a coral reef ecosystem. I. The ECOPATH model and its application to French
868 Frigate Shoals. *Coral Reefs*. 3, 1–11.

869 Power, Mary E., Tilman, David., Estes, James A., Menge, Bruce A., Bond, William J., Mills, Scott., Daily,
870 Gretchen., Castilla, Juan Carlos., Lubchenco, Jane., Paine, R.T., 1996. Challenges in the Quest For
871 Keystone. *Bioscience* 46, 609–620.

872 Prins, T.C., Smaal, A.C., 1994. The role of the blue mussel *Mytilus edulis* in the cycling of nutrients in the
873 Oosterschelde estuary (The Netherlands). *Hydrobiologia* 282, 413–429.

874 Ratsimbazafy, R. A. (1998). Spectres de taille des peuplements benthiques de sables grossiers de la Manche.
875 Thèse de doctorat, Sciences biologiques et fondamentales appliquées. Psychologies. Paris, Muséum
876 National d'Histoire Naturelle. pp 523.

877 Reubens, J.T., Braeckman, U., Vanaverbeke, J., Van Colen, C., Degraer, S., Vincx, M., 2013. Aggregation at
878 windmill artificial reefs: CPUE of Atlantic cod (*Gadus morhua*) and pouting (*Trisopterus luscus*) at
879 different habitats in the Belgian part of the North Sea. *Fish. Res.* 139, 28–34.
880 doi:10.1016/j.fishres.2012.10.011

881 Reubens, J.T., Degraer, S., Vincx, M., 2014. The ecology of benthopelagic fishes at offshore wind farms: a
882 synthesis of 4 years of research. *Hydrobiologia* 727, 121–136. doi:10.1007/s10750-013-1793-1

883 Reubens, J.T., Degraer, S., Vincx, M., 2011. Aggregation and feeding behaviour of pouting (*Trisopterus luscus*)
884 at wind turbines in the Belgian part of the North Sea. *Fish. Res.* 108, 223–227.
885 doi:10.1016/j.fishres.2010.11.025

886 Rombouts, I., Beaugrand, G., Fizzala, X., Gaill, F., Greenstreet, S.P.R., Lamare, S., Le Loc'h, F., McQuatters-
887 Gollop, a., Mialet, B., Niquil, N., Percelay, J., Renaud, F., Rossberg, a. G., Féral, J.P., 2013. Food web
888 indicators under the Marine Strategy Framework Directive: From complexity to simplicity? *Ecol. Indic.*
889 29, 246–254. doi:10.1016/j.ecolind.2012.12.021

890 Rybarczyk, H., Elkaïm, B., 2003. An analysis of the trophic network of a macrotidal estuary: The Seine Estuary
891 (Eastern Channel, Normandy, France). *Estuar. Coast. Shelf Sci.* 58, 775–791. doi:10.1016/S0272-
892 7714(03)00184-7

893 Rybarczyk, H., Ochs, L., Loquet, N., Elkaïm, B. 2003. Analysis of the trophic network of a macrotidal
894 ecosystem: the Bay of Somme (Eastern Channel). *Estuar. Coast. Shelf Sci.* doi:10.1016/S0272-
895 7714(02)00294-9.

896 Salomon, J.C., Breton, M., 1991. Courants résiduels de marée dans la Manche. *Oceanol. Acta*. 11, 47-53.

897 Salomon, J.C., Breton, M., 1993. An atlas of long-term currents in the Channel. *Oceanol. Acta*. 16, 439–448.

898 Sanchez, F., Olaso, I., 2004. Effects of fisheries on the Cantabrian Sea shelf ecosystem. *Ecol. Model.* 172, 151–
899 174.

900 Scheidat, M., Tougaard, J., Basseur, S., Carstensen, J., van Polanen Petel, T., Teilmann, J., Reijnders, P., 2011.
901 Harbour porpoises (*Phocoena phocoena*) and wind farms: a case study in the Dutch North Sea. *Environ.*
902 *Res. Lett.* 6, 025102. doi:10.1088/1748-9326/6/2/025102

903 Shields, M.A., Payne, A.I.L., 2014. Marine renewable energy technology and environmental interactions,
904 Humanity and the Sea. Springer Sciences. pp. 176.

905 Souissi, S., 2007. Etude du comportement natatoire, de la reproduction et du développement d'Eurytemora
906 affinis: combinaison des approches expérimentale au laboratoire et in situ et modélisation. Seine-Aval
907 Scientific Report 3, France, pp. 63.

908 Spitz, J., Richard, E., Meynier, L., Pusineri, C., Ridoux, V., 2006. Dietary plasticity of the oceanic striped dolphin,
909 *Stenella coeruleoalba*, in the neritic waters of the Bay of Biscay. *J. Sea Res.* 55, 309–320.
910 doi:10.1016/j.seares.2006.02.001

911 Spitz, J., Mourocq, E., Schoen, V., Ridoux, V., 2010. Proximate composition and energy content of forage
912 species from the Bay of Biscay: high or lowquality food? *ICES, J. Mar. Sci.* 67, 909–915.
913 doi:10.1093/icesjms/fsq008

914 Tecchio, S., Coll, M., Christensen, V., Company, J.B., Ramírez-Llodra, E., Sardà, F., 2013. Food web structure
915 and vulnerability of a deep-sea ecosystem in the NW Mediterranean Sea. *Deep Sea Res. Part I* 75, 1–15.

916 doi:10.1016/j.dsr.2013.01.003

917 Tecchio, S., Tous Rius, A., Dauvin, J.-C., Lobry, J., Lassalle, G., Morin, J., Bacq, N., Cachera, M., Chaalali, A.,
 918 Villanueva, M.C., Niquil, N., 2015. The mosaic of habitats of the Seine estuary: Insights from food-web
 919 modelling and network analysis. *Ecol. Modell.* 312, 91–101. doi:10.1016/j.ecolmodel.2015.05.026

920 Trites, A.W., Pauly, D., 1998. Estimating mean body masses of marine mammals from maximum body lengths.
 921 *Can. J. Zool.* 76, 886–896.

922 Ulanowicz, R.E., 1986. *Growth and Development: Ecosystems Phenomenology*. Springer-Verlag, New York

923 Ulanowicz, R.E., 1992. Ecosystem health and trophic flow networks. In: Costanza R, Norton BG, Haskell BD
 924 (eds) *Ecosystem health: new goals for environmental management*. Island Press, Washington, DC, pp
 925 190–225.

926 Ulanowicz, R.E., Puccia, C.J., 1990. Mixed trophic impacts in ecosystems. *Coenoses* 5, 7–16.

927 Vallet, C., 1997. Le compartiment suprabenthique des fonds circalittoraux de la manche : composition
 928 faunistique et quantitative, et role des transferts benthos/pelagos. Thèse de doctorat en Sciences
 929 biologiques et fondamentales appliquées. Psychologie, Paris. pp. 422.

930 Valls, A., Gascuel, D., Guénette, S., Francour, P., 2012. Modeling trophic interactions to assess the effects of
 931 a marine protected area: case study in the NW Mediterranean Sea. *Mar. Ecol. Prog. Ser.* 456, 201–214

932 Walters, C., Christensen, V., Pauly, D., 1997. Structuring dynamic models of exploited ecosystems from
 933 trophic mass-balance assessments. *Rev. Fish Biol. Fish.* 7, 139–172. doi:Doi 10.1023/A:1018479526149

934 Westerberg, H., Lagenfelt, I., 2008. Sub-sea power cables and the migration behaviour of the European eel.
 935 *Fish. Manag. Ecol.* 15, 369–375. doi:10.1111/j.1365-2400.2008.00630.x

936 Wilhelmsson, D., Malm, T., 2008. Fouling assemblages on offshore wind power plants and adjacent substrata.
 937 *Estuar. Coast. Shelf Sci.* 79, 459–466. doi:10.1016/j.ecss.2008.04.020

938 Wilhelmsson, D., Malm, T., Öhman, M.C., 2006. The influence of offshore windpower on demersal fish. *ICES*
 939 *J. Mar. Sci.* 63, 775–784. doi:10.1016/j.icesjms.2006.02.001

940 Wilhelmsson, D., Malm, T., Thompons, R., Tchou, J., Sarantakos, G., McCormick, N., Luitjens, S., Gullstrom,
 941 M., Patterson Edwards, J., Amir, O., Dubi, a, 2010. *Greening Blue Energy : Iden fying and managing the*
 942 *biodiversity risks and opportuni es of o ff shore renewable energy* Edited by Dan Wilhelmsson et al.

943 Wilson, J.G., Parkes, A., 1998. Network analysis of the energy flow through the Dublin Bay ecosystem.
 944 *Proceedings of the Royal Irish Academy* 98B, 179.

945 Wolfson, a, Van Blaricom, G., Davis, N., Lewbel, G., 1979. The Marine Life of an Offshore Oil Platform. *Mar.*
 946 *Ecol. Prog. Ser.* 1, 81–89. doi:10.3354/meps001081

947 **Figure Legends**

948 **Figure 1.** Position of the Courseulles-sur-mer offshore wind farm in the Bay of Seine, north-western France.

949 **Figure 2.** Functional groups of the Courseulles-sur-mer ecosystem model arranged using trophic levels as y-
950 axis and benthic/pelagic partitioning on the x-axis. Trophic levels are relative to the BOWF model, before the
951 construction. Functional groups written in blue and bold identify the functional groups for which the
952 biomasses have been set to their accumulated maximum during for the REEF scenario.

953 **Figure 3.** Mixed Trophic Impact (MTI) analysis performed on the BOWF model. Negative (red cells) and
954 positive (blue cells) overall impacts are represented.

955 **Figure 4.** Keystoneness index calculated for the two Ecopath models (“before” and “after” the construction
956 of the Courseulles-sur-mer offshore wind farm; BOWF model is in blue and REEF scenario is in green). The
957 size of the circles is proportional to the functional group biomass.

958 **Figure 5.** Lindeman spine plot of flows and biomasses and transfer efficiencies by discrete trophic levels for
959 the two Ecopath models.

960 **Figure 6.** Differences in compartment throughflows between the two Ecopath models. Note that the y-axis
961 scale is log-transformed, and that this percentage analysis did not consider the difference in absolute values
962 between functional groups. Grey bars identify functional groups for which the biomasses were set to their
963 accumulated maximum during the Ecosim 30-years simulation of ‘Reef Effect’. Black bars represent groups
964 for which variations in biomass were an output of the simulation.

965
966

967 **Table 1.** Biomass values, production over biomass (P/B) ratios, consumption over biomass (Q/B) ratios, and
 968 Ecotrophic Efficiencies (EE) in the two Ecopath models (“before” and “after” the construction of the
 969 Courseulles-sur-mer offshore wind farm in the Bay of Seine; BOWF model and REEF scenario, respectively).
 970 Functional groups for which biomasses were set to their accumulated maximum in the REEF scenario are
 971 marked in bold. Biomasses estimated in the BOWF model were indicated in grey and italic.

		Biomass gC m ⁻²		P/B (year ⁻¹)		Q/B (year ⁻¹)		EE	
		BOWF	REEF	BOWF	REEF	BOWF	REEF	BOWF	REEF
1	Bottlenose dolphins	1.87E-05	8.44E-05	0.08	0.06	23.64	23.15	0	0
2	Harbour porpoises	4.10E-04	1.43E-03	0.08	0.06	40.70	39.59	0	0
3	Harbour seals	6.73E-04	1.89E-03	0.04	0.02	15.90	18.45	0	0
4	Grey seals	2.68E-04	8.73E-04	0.04	0.02	13.23	16.01	0	0
5	Diving seabirds	1.50E-02	9.80E-03	0.09	0.09	55.00	55.01	0	0
6	Surface feeders seabirds	2.08E-03	1.27E-02	0.09	0.18	65.00	30.45	0	0
7	Benthopelagic cephalopods	1.36E-02	1.70E-02	2.80	2.78	15.00	14.64	0.43	0.626
8	Benthic cephalopods	6.22E-03	7.65E-03	3.50	3.50	15.00	14.60	0.918	0.948
9	Fish, mackerel	<i>2.39E-01</i>	2.30E-01	0.83	0.83	4.40	4.40	0.99	0.997
10	Fish, European seabass	1.86E-02	1.63E-02	0.54	0.53	3.20	3.09	0.431	0.439
11	Fish, sharks and rays	1.20E-01	1.64E-01	0.30	0.29	2.44	2.28	0.128	0.132
12	Fish, Atlantic cod	1.97E-02	6.87E-02	1.20	1.20	4.50	4.50	0.445	0.582
13	Fish, whiting	6.80E-03	2.84E-02	1.07	2.40	4.71	10.58	0.987	0.998
14	Fish, Atlantic horse mackerel	<i>1.41E-01</i>	6.36E-02	0.55	0.56	2.44	2.46	0.99	0.999
15	Fish, gurnard	6.30E-03	8.69E-03	0.55	0.54	4.75	4.50	0.001	0.001
16	Fish, pouting	1.66E+00	3.85E+00	1.32	1.32	8.97	8.97	0.037	0.098
17	Fish, poor cod	8.60E-03	1.64E-03	1.50	1.67	8.97	9.69	0.962	0.998
18	Fish, European pilchard	<i>4.76E+00</i>	3.68E+00	0.99	1.04	7.20	7.45	0.99	0.997
19	Fish, European sprat	<i>1.08E-01</i>	1.28E-01	1.34	1.33	11.59	11.39	0.99	0.999
20	Fish, piscivorous	<i>2.42E-01</i>	4.86E-03	0.87	1.03	5.11	5.54	0.99	0.995
21	Fish, planktivorous	<i>8.19E-01</i>	7.22E-01	1.04	1.09	8.38	8.62	0.99	0.995
22	Fish, benthos feeders	<i>1.21E+00</i>	2.50E+00	0.92	0.91	2.99	2.63	0.99	0.997
23	Fish, sea bream	2.98E-02	8.33E-02	0.58	0.57	4.47	4.29	0.298	0.319
24	Fish, sole	<i>5.07E-02</i>	9.80E-02	0.70	0.70	3.20	3.20	0.99	0.999
25	Fish, European plaice	<i>2.16E-02</i>	5.33E-02	0.85	0.85	3.42	3.33	0.99	0.997
26	Fish, other flatfish	<i>6.18E-03</i>	2.70E-02	0.82	1.09	4.48	3.35	0.99	0.99
27	Benthic invertebrate, predators	2.94E+00	3.01E+00	2.24	2.89	11.20	14.44	0.978	0.993
28	Benthic invertebrate, filter feeders	<i>3.12E+00</i>	4.78E+00	2.40	3.27	12.00	16.34	0.99	0.999
29	Benthic invertebrate, bivalves	1.95E+01	4.29E+01	0.60	1.20	3.00	6.00	0.013	0.014
30	King scallops	7.70E-01	7.43E-01	0.90	0.89	4.50	4.45	0.58	0.588
31	Benthic invertebrate, deposit feeders	<i>3.57E+00</i>	2.98E+00	2.90	3.05	14.50	15.23	0.99	0.994
32	Suprabenthos	<i>2.00E+00</i>	1.71E+00	5.66	5.82	28.30	29.10	0.99	0.994
33	Meiofauna	<i>9.70E-01</i>	1.06E+00	15.00	15.06	42.86	43.02	0.99	0.991
34	Zooplankton	1.72E+00	1.79E+00	50.00	47.45	150.00	141.80	0.882	0.998

35	Bacteria	7.50E-01	7.70E-01	72.80	72.34	145.60	144.68	0.219	0.246
36	Phytoplankton	3.24E+00	3.24E+00	150.00	150.00			0.758	0.997
37	Detritus	1.90E+01	1.92E+01						

972

973

974 **Table 2.** General system statistics and ENA indices for the BOWF model compared to values obtained for
 975 similar Northern European systems. The Total System Throughput (T., gC m⁻² year⁻¹) was calculated as the
 976 sum of all the flows in the food web. The Finn's Cycling Index (FCI) gives the percentage of all flows generated
 977 by cycling. The Ascendency (A) is a measure of the system activity (Total System Throughput) linked to its
 978 degree of organization (Average Mutual Information) and is given in gC m⁻² year⁻¹.

Ecosystems	T..	A	FCI	Biomass/Throughput	Total living biomass	Reference for Ecopath models
Seine estuary	4584.92 - 1161.05	1442.6- 6058.6	3.65 -20.65	0.07-0.022	10.23-40.40	Tecchio et al., 2015
Bay of Somme	2312.1	2401.6	12.2	0.01	27.44	Rybarczyck et al., 2003
BOWF model	1607.616	1869.1	9.16	0.030	48.12	
REEF scenario	1831,933	2156,9	12,86	0.041	74.73	
Dublin Bay	724.69	848.5	31.9			Wilson and Parkes, 1998

979

980

981 **Figure 1**

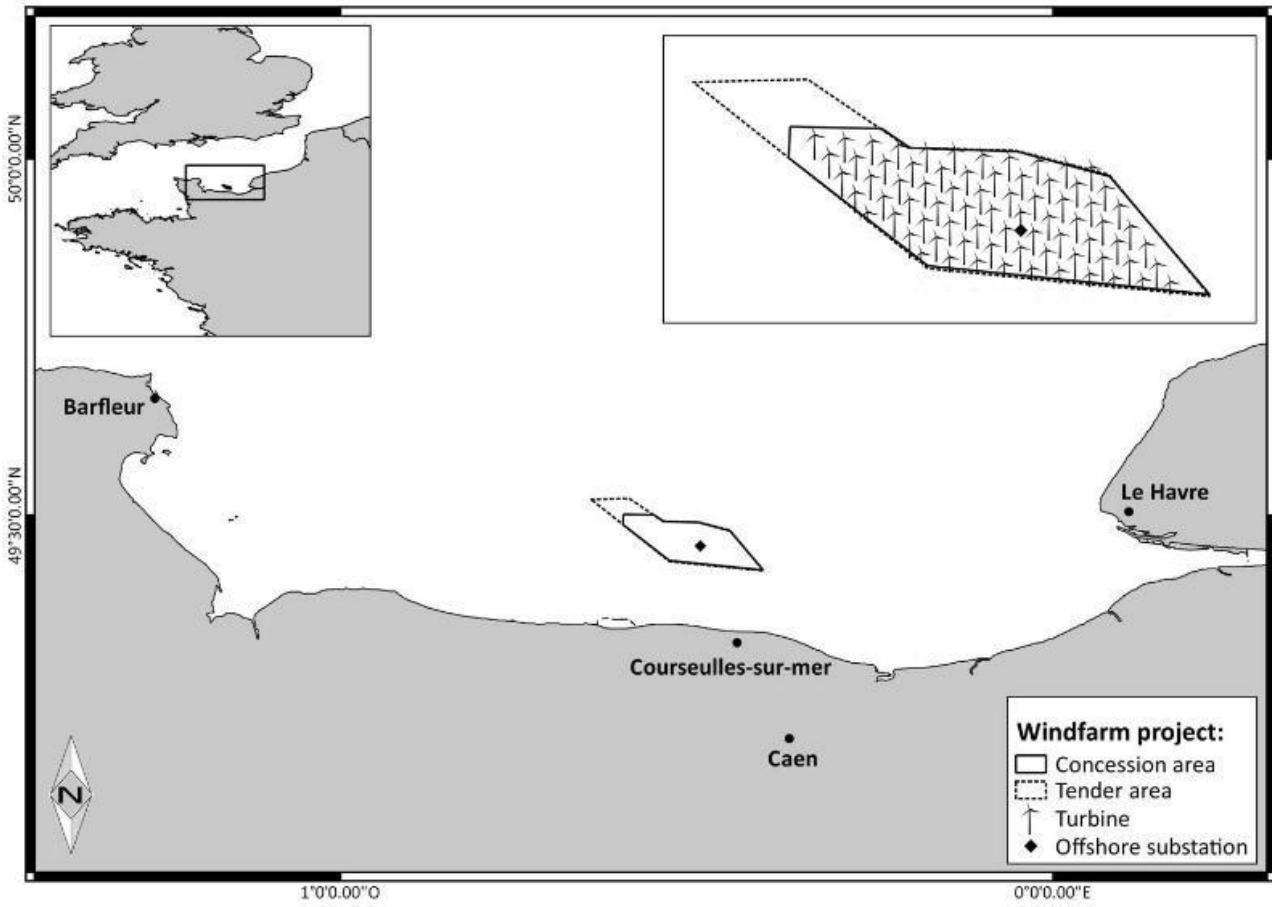

982
983
984
985

Figure 2

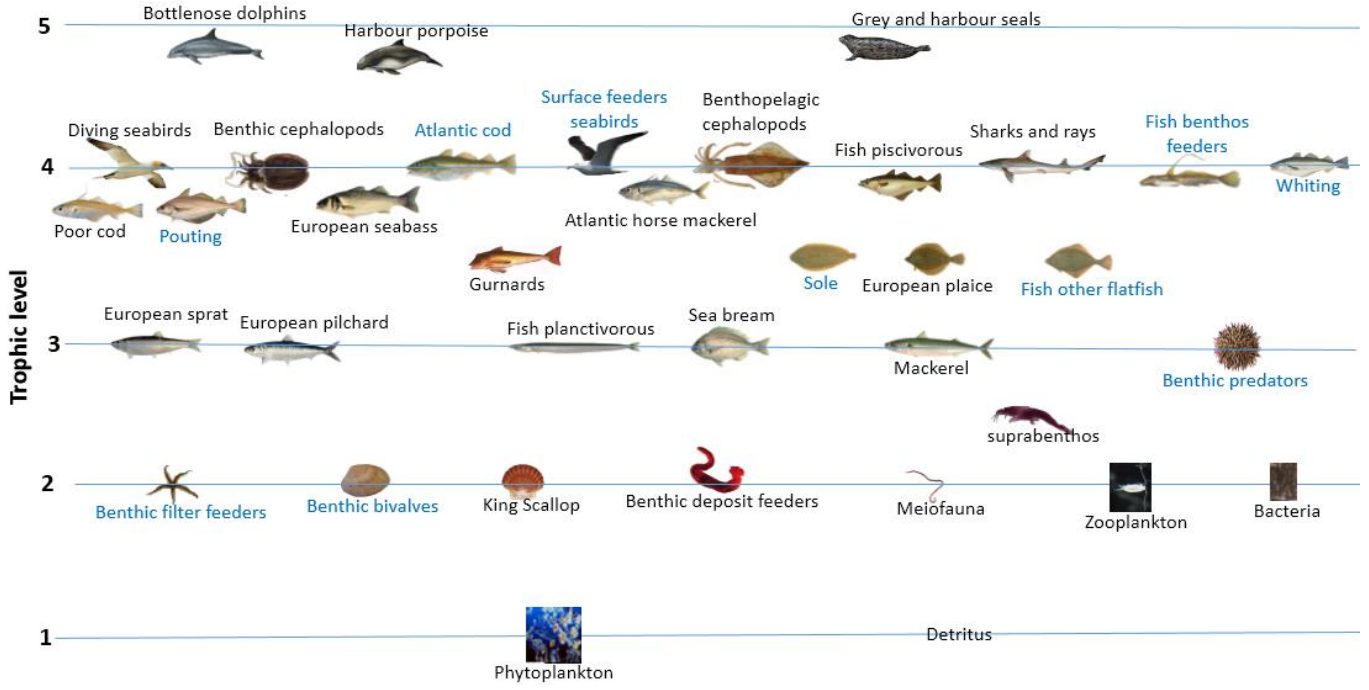
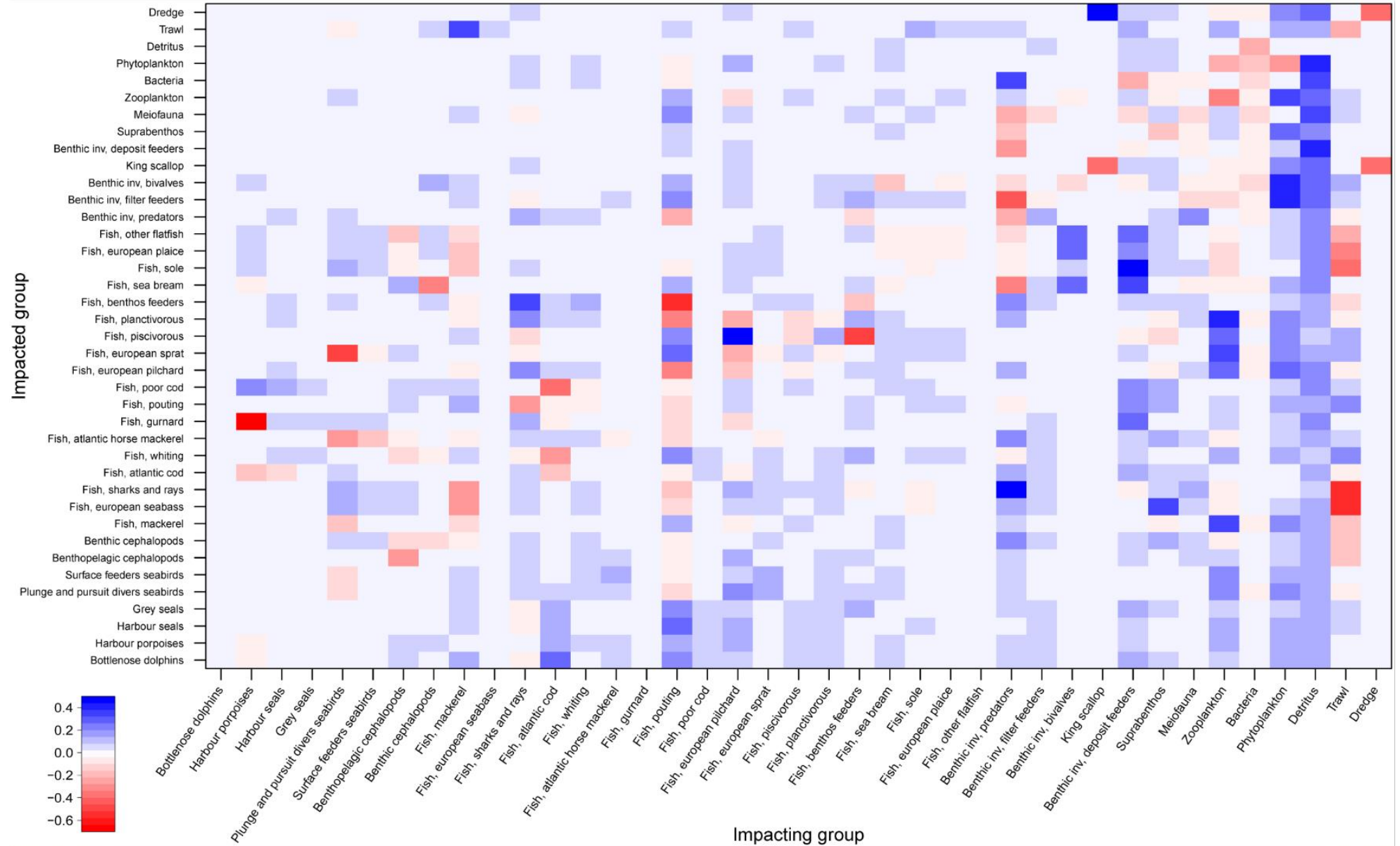
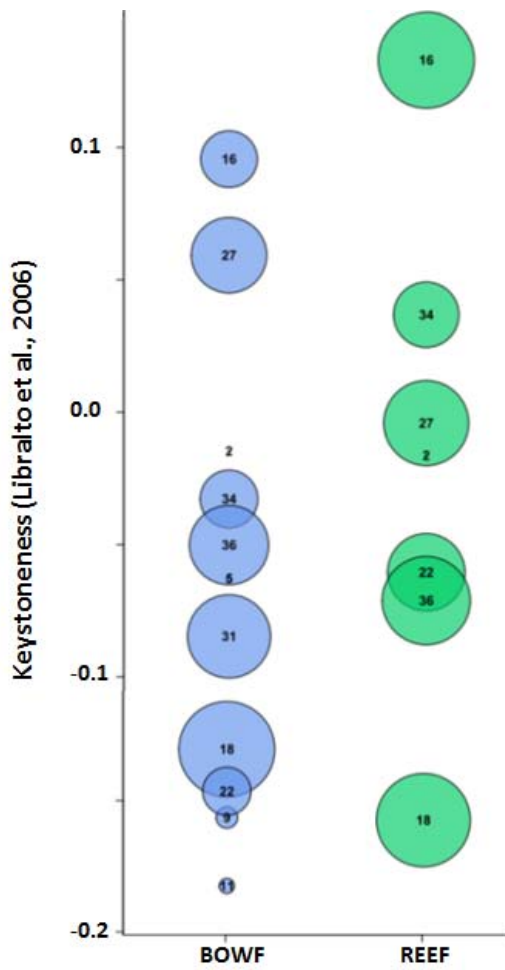

Figure 3



991 **Figure 4**
 992



- | | |
|--|-----------------------------------|
| 2 – Harbour porpoises | 22 – Fish, benthos feeders |
| 5 – Plunge and pursuit divers seabirds | 27 – Benthic inv, predators |
| 9 – Fish, mackerel | 31 – Benthic inv, deposit feeders |
| 11 – Fish, sharks and rays | 34 – Zooplankton |
| 16 – Fish, pouting | 36 – Phytoplankton |
| 18 – Fish, european plichard | |

993

994
995

Figure 5

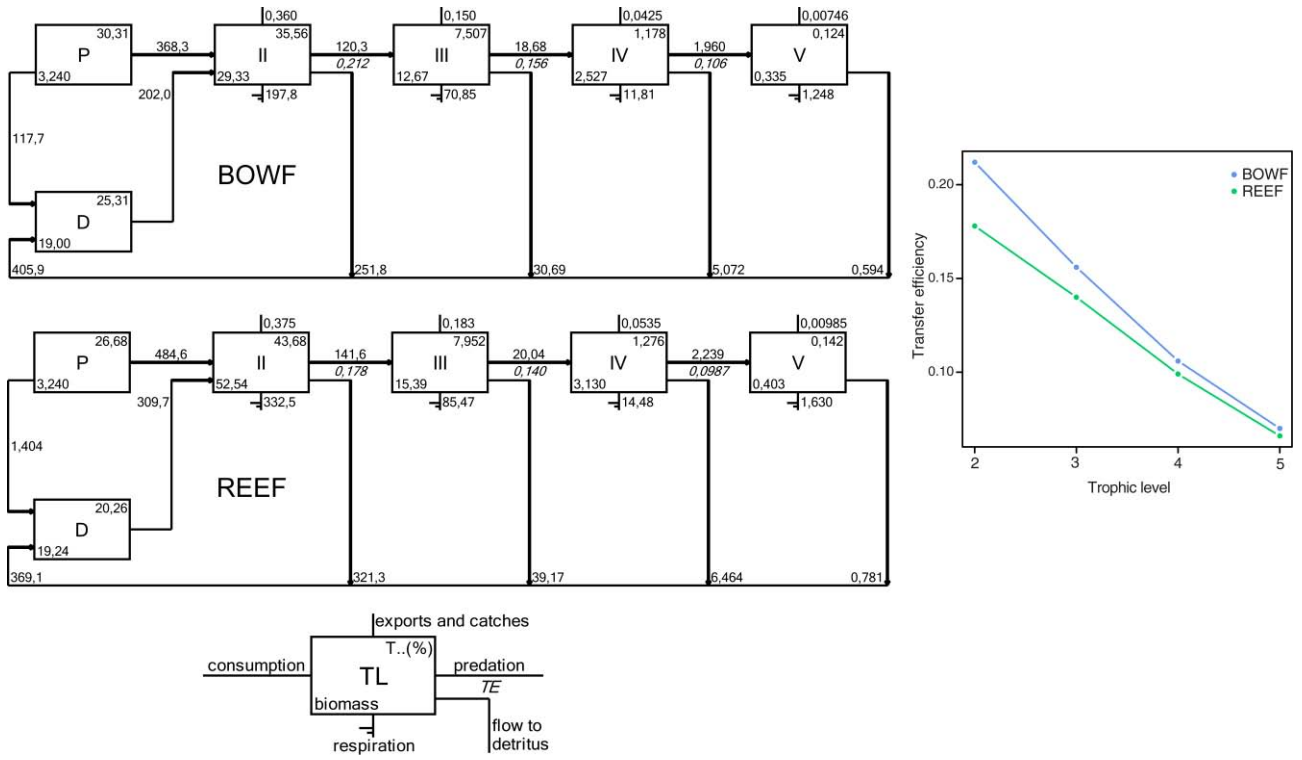

996

Figure 6

