



HAL
open science

Thermal energy harvesting: thermomagnetic versus thermoelectric generator

Morgan Morgan.Almanza@gmail.Com Almanza, Alexandre Pasko, A. Bartok, Frédéric Mazaleyrat, Martino Lobue

► To cite this version:

Morgan Morgan.Almanza@gmail.Com Almanza, Alexandre Pasko, A. Bartok, Frédéric Mazaleyrat, Martino Lobue. Thermal energy harvesting: thermomagnetic versus thermoelectric generator. 7th International Conference on Magnetic Refrigeration at Room Temperature (Thermag VII), Sep 2016, Turin, Italy. hal-01395695

HAL Id: hal-01395695

<https://hal.science/hal-01395695v1>

Submitted on 29 Nov 2016

HAL is a multi-disciplinary open access archive for the deposit and dissemination of scientific research documents, whether they are published or not. The documents may come from teaching and research institutions in France or abroad, or from public or private research centers.

L'archive ouverte pluridisciplinaire **HAL**, est destinée au dépôt et à la diffusion de documents scientifiques de niveau recherche, publiés ou non, émanant des établissements d'enseignement et de recherche français ou étrangers, des laboratoires publics ou privés.

Thermal energy harvesting: thermomagnetic versus thermoelectric generator

M. Almanza^{(a)*}, A. Pasko^(a), A. Bartok^(a), F. Mazaleyra^(a), M. LoBue^(a)

^(a) SATIE, ENS Cachan, CNRS, Université Paris-Saclay, 94235 Cachan, France

*Corresponding author. E-mail: morgan.almanza@ens-cachan.fr

ABSTRACT

We compare the efficiency and the power density of thermoelectric and thermomagnetic generators at maximum power. The performances of thermomagnetic generator are computed using an equation of state, either extrapolated from experimental data for 2nd order transition or deduced using a phenomenological Landau model on measured data for 1st order transition. The performances of thermoelectric generator are computed using the Onsager model. Moreover, the heat exchange in finite time is estimated using a simple model of thermal conductance. According to the results, thermomagnetic generator is more efficient and have slightly higher power density than thermoelectric for temperature difference lower than 10 K. Therefore low grade heat thermal energy harvesting could consider thermomagnetic generator.

Keywords: magnetocaloric materials, thermal energy harvesting, thermomagnetic cycle, thermoelectric generator, thermomagnetic generator

1. INTRODUCTION

As indicated by the US department of energy [1], high and low grade waste heat are widespread, for example in the USA between 20% and 50% of the global industrial energy inputs, corresponding to 1.5 to 4 quadrillion Wh/yr, is lost as waste heat. This makes thermal energy harvesting at different scales a key research area to improve the sustainability of our electricity supply. So far thermal energy harvesting is mainly oriented towards thermoelectric generation (TEG). However, recent advances on magnetocaloric materials (MCM), aimed to applications to room temperature magnetic refrigeration, could pave the way for a new generation of thermomagnetic generators (TMG) with high power density and better efficiency.

TMG is based on the magnetization change in MCM, induced by temperature (i.e. cycling between thermal contact with a hot and cold reservoirs) and by successive application and removal of an external magnetic field. Work can be produced in mechanical [2] or electrical [3] forms. Although TEGs are very simple thanks to a direct production of electricity, TMGs can potentially attain better performances due to their higher relative efficiency.

2. FINITE TIME THERMODYNAMICS APPLIED TO THERMOGENERATOR

One of the pillars of thermodynamics is the limitation in the conversion of heat into work imposed by the second law. This maximum is reached with a fully reversible cycle – the Carnot cycle where thermodynamic transformations are quasi-static. From the practical viewpoint, heat exchange in finite time and its irreversibility has to be considered, as proposed in [4] where a heat exchange model is introduced. Whatever the thermogenerator used, the main consequence is the introduction of a tradeoff between efficiency and power [4]. Depending on the thermogenerator, different sources of irreversibility have to be considered: heat transfer rate between the heat reservoir and the engine, the heat leaks from the hot to the cold reservoir and the internal dissipation, only considered in TEG. They are modeled with thermal conductance k_h and k_c , the thermal leakage conductance k_l and the dissipated heat Q_{loss} , respectively, as shown in Figure 1.

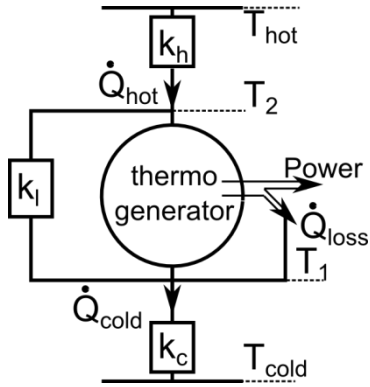

Figure 1. Model of irreversibility in thermogeneration.

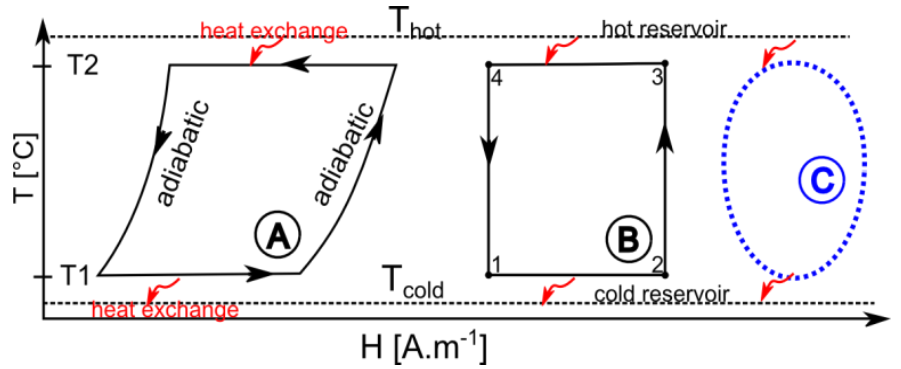

Figure 2 Examples of two ideal cycles: (A) isotope-adiabatic, (B) isotope-isofield, and a generic cycle (C).

In order to estimate the power, the heat exchange is modeled with $\delta Q_{hot} = -k_h(T_2 - T_{hot})dt$ and $\delta Q_{cold} = k_c(T_1 - T_{cold})dt$, where T_{hot} and T_{cold} are the temperatures of two reservoirs, T_1 and T_2 are the material temperatures when in contact with cold or hot reservoir respectively, and t is time. Different configurations of thermogenerators can be assessed as a function of the operating points, the thermodynamic cycles (Figure 2), the temperature difference between the hot and the cold reservoir (ΔT_{res}), the active material and its volume, each one with different relative efficiency and power. Considering the relative efficiency at the maximum power (EMP) [5] using realistic values of heat transfer coefficient, we compare thermomagnetic generator and thermoelectric generator in terms of relative efficiency and power density for different ΔT_{res} . The relative efficiency is the efficiency divided by the Carnot efficiency.

3. THERMOMAGNETIC GENERATOR

Thermomagnetic generator use the coupling between the entropy and the magnetization of MCM, given by the entropy $s(T, H)$ and the magnetization $M(T, H)$ functions of temperature T and magnetic field H , with an example of ideal equation of state in Figure 3.

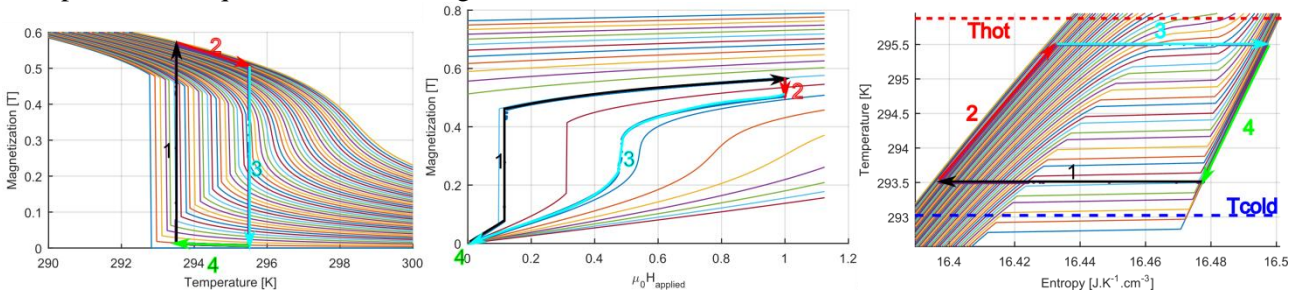

Figure 3. From the left to the right: $M(T)$ at different fields, $M(H)$ at different temperatures, $T(s)$ at different fields derived from the equation of state [6] with an example of thermomagnetic cycle corresponding to cycle (B) (Figure 2).

The thermomagnetic cycle (B) drawn in Figure 2 and Figure 3 has four steps:

- 1- Isotemperature transformation where the MCM is in thermal contact with the cold reservoir and the applied field increases in order to maintain the temperature constant;
- 2- Isofield transformation where the MCM is in thermal contact with the hot reservoir at constant field $\mu_0 H = 1$ T;
- 3- Isotemperature transformation where the MCM is in thermal contact with the hot reservoir and the applied field decreases in order to maintain the temperature constant;
- 4- Isofield transformation where the MCM is in thermal contact with the cold reservoir at constant field $\mu_0 H = 0$ T.

In our study the MCM is at thermodynamic equilibrium and the model does not take into account intrinsic irreversibility of MCM, namely both 2nd and 1st order transitions are assumed to take place at equilibrium (i.e. entropy production associated with the transition is zero, $ds_i = 0$). From standard thermodynamic relations applied to an elementary volume of MCM, always assumed to be in quasi-static process, we write:

$$Tds - Tds_i = c_H dT + T \frac{\partial s}{\partial H} dH - Tds_i = \delta Q \quad \text{and} \quad du = \delta Q - \vec{M} d\vec{B} \quad (1)$$

with T the temperature, c_H the thermal capacity at constant field, u the internal energy per unit of volume, Q the heat exchange per unit volume and \vec{M} the magnetization. Because thermodynamic convention is used, work produced by the system is counted as negative.

The TMG need thermal switch that allows the MCM to be in thermal contact alternatively with the hot and the cold reservoir. We considered the conductances k_h and k_c controlled between two values k_{large} and k_{small} , i.e when the MCM is in thermal contact with the hot reservoir, $k_h = k_{large}$, $k_c = k_{small}$, conversely when in contact with the cold reservoir $k_c = k_{large}$ and $k_h = k_{small}$, with $k_{large} \gg k_{small}$. The power density and the efficiency depend on k_{large} , k_{small} , as in magnetic refrigeration [7]. Because the conductance depends on the geometry and the volume, we introduce conductance per unit of volume. The constant k_{large} is expected to assume values of about $1 \text{ W} \cdot \text{cm}^{-3} \cdot \text{K}^{-1}$ using 1 mm thickness sheet of MCM with $1000 \text{ W} \cdot \text{m}^{-2} \cdot \text{K}^{-1}$ heat transfer coefficient, as commonly used in magnetic refrigeration with forced flow. The constant k_{small} , associated with the heat leakage, is assumed null.

The entropy is divided in two parts: the lattice contribution $s_{lat}(T)$ with its thermal capacity $T \frac{\partial s_{lat}}{\partial T}$ constant, and the magnetocaloric contribution $s_{mag}(T, H)$ which is central to the conversion. The lattice entropy does not contribute to the conversion because it does not produce change in magnetization as shown by the Maxwell relation. In the thermomagnetic cycle \textcircled{B} (Figure 2), it induces an extra heat exchanged with the reservoirs, i.e heat leakage, mathematically given by the integration of $T \frac{\partial s_{lat}}{\partial T}$ between T_2 and T_1 . This term is like putting a non-active material alternatively in contact with the hot and the cold reservoir. Because the term is smaller than $T \frac{\partial s_{mag}}{\partial H}$ with 1st order MCM, the performance of TMG with 1st order Figure 5 is better than with 2nd order Figure 4. Numerical simulation of TMG from [4] gives:

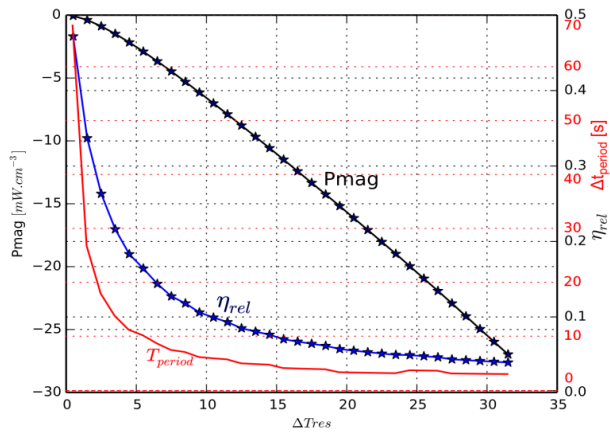

Figure 4. Maximum power and relative efficiency for different ΔT_{res} for cycle \textcircled{B} with $\mu_0 H = 1 \text{ T}$ and 2nd order $\text{Pr}_{0.65} \text{Sr}_{0.35} \text{MnO}_3$ and $\Delta T_{adia} = 1.2 \text{ K}$ [7].

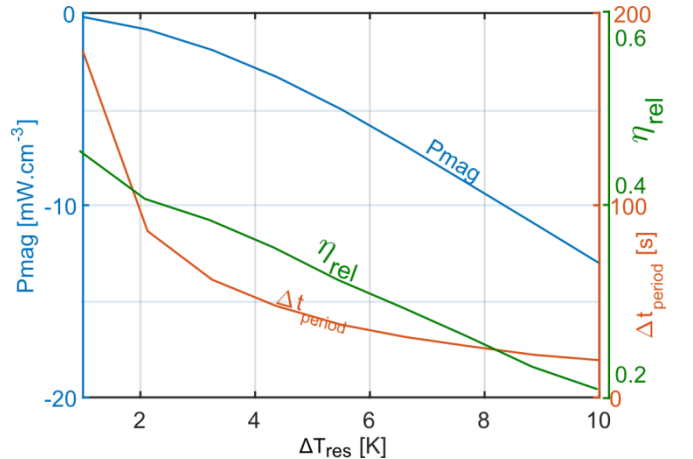

Figure 5. Maximum power and relative efficiency for different ΔT_{res} for cycle \textcircled{B} with $\mu_0 H = 1 \text{ T}$ and 1st order $\text{Mn}_{1.3} \text{Fe}_{0.65} \text{P}_{0.5} \text{Si}_{0.5}$ [6].

4. THERMOELECTRIC GENERATOR

Assuming the system at local equilibrium, because the system is in quasi-static process, and stationary state we obtained from the relation of Onsager [8] the fluxes (Figure 1):

$$\begin{aligned} Q_{hot} &= \alpha N T_1 - \frac{1}{2} R_{in} I^2 + k_l (T_1 - T_2) \\ Q_{cold} &= \alpha N T_2 + \frac{1}{2} R_{in} I^2 + k_l (T_1 - T_2) \end{aligned} \quad (2)$$

with α the Seebeck coefficient ($185 \mu\text{V} \cdot \text{K}^{-1}$ from [8]), N the number of junctions, R_{in} the internal electrical resistance. The current is deduced from $\alpha N (T_2 - T_1) = I (R_{in} + R_{load})$ with R_{load} the load resistance connected to the thermoelectric generator. The use of Onsager model allows a description of the internal dissipation, $R_{in} I^2$, and of the heat leakage between reservoirs, $k_l (T_1 - T_2)$, and thus puts forward the irreversibility due to thermal exchanges. For different ΔT_{res} , the length of the TEG is optimized, giving a realistic estimate of the efficiency at the maximum power as proposed in [8], [9]:

$$P = \frac{\Delta T_{res}^2}{l+l_c} \frac{\alpha^2}{2\rho(l+n)\left(1+\frac{2rl_c}{l}\right)^2} \quad \text{and} \quad \eta_{rel} = \left(\left(1 + \frac{2rl_c}{l}\right)^2 \left(2 - \frac{\Delta T_{res}}{2T_{hot}} + \frac{4}{ZT_{hot}} \left(\frac{l+n}{l+2rl_c}\right)\right) \right)^{-1} \quad (3)$$

Here ρ is the electrical resistivity ($10^{-5}\Omega \cdot m$ from [8]); l the length of the thermoelement; l_c the length of the insulating ceramic layer ($0.5mm$); $n = \rho_c/\rho$ and $r = \lambda/\lambda_c$ where ρ_c and λ_c are the electrical and thermal contact resistivity ($n = 0.1mm$ and $r = 0.2$ from [8], [9]). Factor of merit ZT_h is then 0.8. Same as for TMG, the addition of conductances k_h, k_c based on [10] gives an optimum when $k_h = k_c = \frac{S}{\lambda l} \sqrt{Z(T_2 + T_1)/2}$ and $R_{load} = R_{in} \sqrt{Z(T_2 + T_1)/2}$. As expected, the performance is lower when the heat exchange is taken into account.

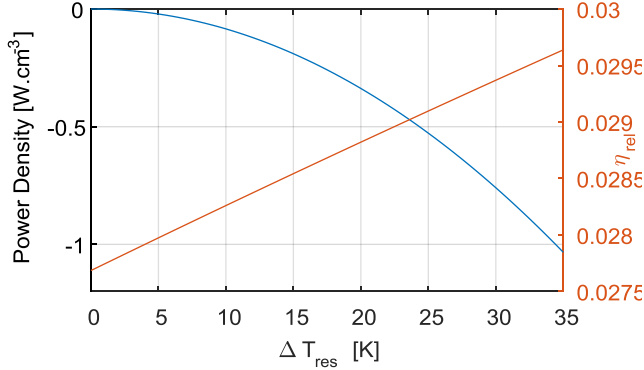

Figure 6. Maximum power for different ΔT_{res} and relative efficiency for TEG without the heat exchanger.

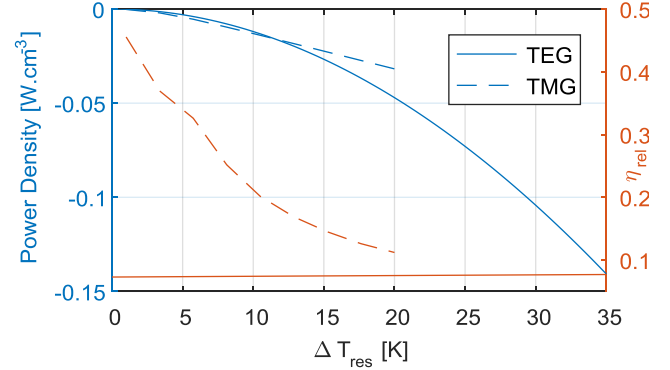

Figure 7. Maximum power for different ΔT_{res} and relative efficiency for TEG with the heat exchanger (solid lines) and TMG with 1st order MCM (dashed lines).

5. CONCLUSIONS

As shown in Figure 7, for large ΔT_{res} the power density is higher for TEG, however for small ΔT_{res} , lower than 10 K, the power density is equal while the efficiency is always much higher for TMG with first order phase transition MCM. Although the weight of the magnetic circuit and the efficiency of conversion of the magnetic energy into electricity are not included, improvement on the shape of the thermodynamic cycle could be expected. Moreover, further studies are needed to have better estimation of the coefficient used in the heat exchange conductance.

REFERENCES

- [1] US Department of Energy, "Waste Heat Recovery: Technology and Opportunities in U.S. Industry." prepared by BCS, Incorporated, Mar-2008.
- [2] M. Ujihara, G. P. Carman, and D. G. Lee, "Thermal energy harvesting device using ferromagnetic materials," *Appl. Phys. Lett.*, vol. 91, no. 9, p. 93508, Aug. 2007.
- [3] T. Christiaanse and E. Brück, "Proof-of-Concept Static Thermomagnetic Generator Experimental Device," *Metall. Mater. Trans. E*, vol. 1, no. 1, pp. 36–40, Mar. 2014.
- [4] M. Almanza, A. Pasko, F. Mazaleyrat, and M. LoBue, "Numerical study of thermomagnetic cycle," *J. Magn. Mater.*, vol. submitted, 2016.
- [5] F. L. Curzon, "Efficiency of a Carnot engine at maximum power output," *Am. J. Phys.*, vol. 43, no. 1, p. 22, 1975.
- [6] A. Pasko, A. Bartok, K. Zehani, L. Bessais, F. Mazaleyrat, and M. LoBue, "X-ray diffraction analysis of the magnetoelastic phase transition in the Mn-Fe-P-Si magnetocaloric alloy," *AIP Adv.*, vol. 6, no. 5, p. 56204, May 2016.
- [7] M. Almanza, A. Kedous-Lebouc, J.-P. Yonnet, U. Legait, and J. Roudaut, "Magnetic refrigeration: recent developments and alternative configurations," *Eur. Phys. J. Appl. Phys.*, vol. 71, no. 1, p. 10903, Jul. 2015.
- [8] D. M. Rowe, Ed., *CRC handbook of thermoelectrics*. Boca Raton, FL: CRC Press, 1995.
- [9] D. M. Rowe and G. Min, "Evaluation of thermoelectric modules for power generation," *J. Power Sources*, vol. 73, no. 2, pp. 193–198, Jun. 1998.
- [10] C. Goupil, H. Ouerdane, and Y. Apertet, "Thermoélectricité Thermodynamique et applications," *Tech. Ing. Vecteurs Énergétiques Hors Électricité Convert.*, vol. TIB206DUO, no. be8080, 2013.