

DARBOUX INTEGRABLE SYSTEM WITH A TRIPLE POINT AND PSEUDO-ABELIAN INTEGRALS

AYMEN BRAGHTHA

ABSTRACT. We study pseudo-abelian integrals associated with polynomial perturbations of Darboux integrable system with a triple point. Under some assumptions we prove the local boundedness of the number of their zeros. Assuming that this is the only non-genericity, we prove that the number of zeros of the corresponding pseudo-abelian integrals is bounded uniformly for nearby Darboux integrable foliations.

1. INTRODUCTION

Abelian integrals are integrals $I(h) = \int_{\gamma(h)} \eta$ of polynomial or rational one-forms along cycles $\gamma(h) \in H_1(H^{-1}(h))$, $H \in \mathbb{C}[x, y]$. Abelian integrals appear as principal part of Poincaré displacement function of the perturbation $dH + \varepsilon\eta$ along $\gamma(h)$. Their zeros are related to limit cycles born in the perturbation. In [11, 7], Varchenko and Khovanskii prove the following result

Theorem 1.1. *There exist a uniform bound, depending only on the degree of H and η , for the number of real zeros of Abelian integrals.*

Arnold posed with insistence the analogous problem for more general polynomial perturbation of integrable systems. In particular, for perturbation of systems having a Darboux first integrals $H = \prod P_i^{\alpha_i}$, $P_i \in \mathbb{C}[x, y]$. Then instead of Abelian integrals, one encounters pseudo-Abelian integrals. Pseudo-Abelian integrals naturally appear in generalizations to classes bigger than the Hamiltonian class. The simplest case is the case of Darboux integrable planar foliations $\mathcal{F} = \{M \frac{dH}{H} = 0\}$, where $H = \prod P_i^{\alpha_i}$ is a product of real powers of bivariate polynomials and $M = \prod P_i$ is the so-called integrating factor, so the form $\omega = M \frac{dH}{H}$ is a polynomial one-form. Poincaré-Pontryagin criterium claims that in the regular part the limit cycles of the perturbed foliations $\mathcal{F}_\varepsilon = \{\omega + \varepsilon\eta = 0\}$ can be born only from those cycles δ of foliation \mathcal{F} for which the integral $\int_\delta \frac{\eta}{M}$ vanishes. This integral is called the pseudo-Abelian integral, and currently the main open question is the existence of a uniform bound on the number of its zeros.

2. FORMULATION AND MAIN RESULT

This paper is a part of program of Bobieński, Mardešić and Novikov to extend the Varchenko-Khovanskii theorem from Abelian integrals to pseudo-Abelian integrals. After studying the generic cases [2, 9] and some nongeneric cases [1, 3, 4], in this work we study a nongeneric case. Let

Date: December 27, 2017.

2010 Mathematics Subject Classification. 34C07, 34C08.

Key words and phrases. Abelian integrals, Limit cycles, Darboux integrability.

$\mathcal{F} = \{M \frac{dH}{H} = 0\}$ denote a foliation with a triple point (assume it to be at the origin), where

$$H = P_0^\epsilon \prod_{i=1}^k P_i^{\epsilon_i}, \quad M = P_0 \prod_{i=1}^k P_i, \quad P_i \in \mathbb{R}[x, y], \quad \epsilon, \epsilon_i > 0,$$

so that the level curves $\{P_0 = 0\}$, $\{P_1 = 0\}$ and $\{P_2 = 0\}$ intersect transversally two by two at the origin which is the only triple point. Let $\mathcal{F}_\lambda = \{M_\lambda \frac{dH_\lambda}{H_\lambda} = 0\}$ be a foliation unfolding \mathcal{F} , M_λ an integrating factor, where

$$H_\lambda = P_\lambda^\epsilon \prod_{i=1}^k P_i^{\epsilon_i}, \quad M_\lambda = P_\lambda \prod_{i=1}^k P_i. \quad (1)$$

Generically, a triple point unfolds into three saddles-type singular points p_0^λ, p_1^λ and p_2^λ correspond to the transversal intersections of level curves $\{P_1 = 0\}$ and $\{P_\lambda = 0\}$, $\{P_1 = 0\}$ and $\{P_2 = 0\}$, and $\{P_2 = 0\}$ and $\{P_\lambda = 0\}$. Here also appears a center p_0^c in the triangular region bounded by these levels curves- see Figure 1.

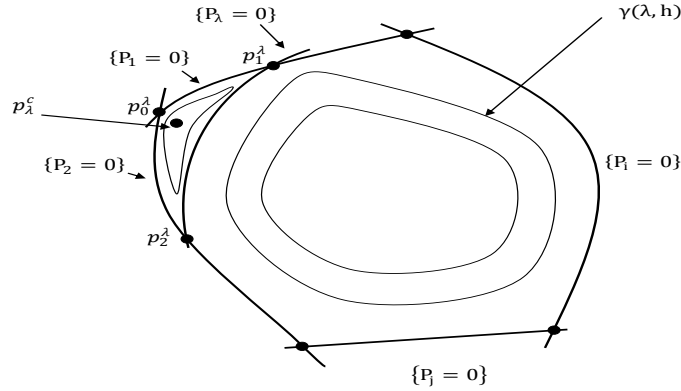

FIGURE 1. The phase portrait of H_λ

Assume that the system $M_\lambda \frac{dH_\lambda}{H_\lambda}$ has a family of cycles $\gamma(\lambda, h) \subset H_\lambda^{-1}(h)$ filling a connected component of $\mathbb{R}^2 \setminus \{P_\lambda P_1 \cdots P_k = 0\}$, which we denote by D . The period annulus D is bounded by $\{P_\lambda = 0\}$, $\{P_1 = 0\}$, $\{P_2 = 0\}$ and some separatrices $\{P_i = 0\}$, $i = 3, \dots, k$.

Consider a polynomial perturbation of the system $M_\lambda \frac{dH_\lambda}{H_\lambda}$.

$$M_\lambda \frac{dH_\lambda}{H_\lambda} + \kappa \eta, \quad \eta = Rdx + Sdy, \quad R, S \in \mathbb{R}[x, y], \quad \kappa > 0.$$

The linear part in perturbation parameter κ of the Poincaré first return map is given by the pseudo-Abelian integral

$$I(\lambda, h) = \int_{\gamma(\lambda, h)} \frac{\eta}{M_\lambda}. \quad (2)$$

We prove the existence of a local bound for the number of zeros of pseudo-Abelian integrals. Let $\Omega^k(\lambda, n_0, n_1, \dots, n_k; n)$ be the following, finite dimensional space of polynomial system with Darboux type first integral:

$$\Omega^k(\lambda, n_0, n_1, \dots, n_k; n) := \left\{ M_\lambda \frac{dH_\lambda}{H_\lambda} + \kappa \eta : H_\lambda = P_\lambda^\epsilon \prod_{i=1}^k P_i^{\epsilon_i}, \right. \\ \left. \deg P_\lambda \leq n_0, \deg P_i \leq n_i, \deg(R, S) \leq n \right\},$$

where $M_\lambda = P_\lambda \prod_{i=1}^k P_i$. The parameters of the space $\Omega^k(\lambda, n_0, n_1, \dots, n_k; n)$ are positive exponents $(\epsilon, \epsilon_1, \dots, \epsilon_k)$, coefficients of polynomials P_λ, P_i and coefficients of the polynomials perturbation (R, S) . We distinguish an open subset $\Omega_0^k(\lambda, n_0, n_1, \dots, n_k; n)$ defined by the condition that the unperturbed system (with $\kappa = 0$) admits a period annulus D and the following genericity assumptions are satisfied

- **A₁**. The Darboux first integral H_λ is regular at infinity.
- **A₂**. $\frac{\partial P_\lambda}{\partial \lambda}|_{(0,0,0)} \neq 0$.
- **A₃**. The level curves $\{P_i = 0\}$, $i = 3, \dots, k$ are smooth and intersect transversally two by two. Moreover, there are not triple intersection points, for $i = 3, \dots, k$.
- **A₄**. η vanishes to the order ≥ 4 at $(x, y) = (0, 0)$ (technical condition)

Theorem 2.1. *Let $\Omega_0 \in \Omega_0^k(\lambda, n_0, n_1, \dots, n_k; n)$. Assume that the pseudo-Abelian integral I_{Ω_0} associated to Ω_0 in (2) is not identically zero. Consider the pseudo-Abelian integrals associated to $\Omega \in \Omega_0^k(\lambda, n_0, n_1, \dots, n_k; n)$ in a neighborhood of Ω_0 . Then, there exists an upper bound $Z(\Omega_0; k, n_0, \dots, n_k; n)$ for the number of zeros of the pseudo-Abelian integrals associated to $\Omega \in \Omega_0^k(\lambda, n_0, n_1, \dots, n_k; n)$ close to Ω_0 .*

The main problem is that the Darboux integrable systems $M_\lambda \frac{dH_\lambda}{H_\lambda}$ have a small nest of cycles which shrinks to the origine $(0, 0)$ as $\lambda \rightarrow 0$, i.e. the center p_c^λ generates a possible ramification points of $I(\lambda, h)$ located on a circle whose radius is of order $|\lambda|^{\epsilon_1 + \epsilon_2}$. Thus, we can no directly repeat the argument from [2] to get an λ -independent estimate.

3. CONNECTION WITH BOBIEŃSKI'S RESULT

In [1], the author considers a polynomial one-form $\omega_\epsilon = M_\epsilon \frac{dH_\epsilon}{H_\epsilon}$ having a Darboux first integral:

$$H_\epsilon = (x - \epsilon)^a P \prod_{i=1}^k P_i^{a_i}, \quad M_\epsilon = (x - \epsilon) P \prod_{i=1}^k P_i \quad (\text{integrating factor}),$$

where $P, P_i \in \mathbb{R}[x, y]$, $a, a_i \in \mathbb{R}_+$ and ϵ is a sufficiently small parameter. He imposes the following genericity assumptions

- (1) The Darboux first integral H_ϵ is regular at infinity.
- (2) For $\epsilon = 0$, the polycycle $\gamma(0, 0)$ consists of the edges $\gamma_i(0, 0)$ contained in a smooth part of the level curve $P_i^{-1}(0)$. Any vertex p_{ij} , except $(0, 0)$, corresponds to the transversal intrsection of level curves $P_i^{-1}(0)$ and $P_j^{-1}(0)$.
- (3) The polynomial P has a critical point of Morse type $(0, 0)$, i.e. $P(x, y) = y^2 - x^2 + \text{h.o.t.}$ Other polynomials P_j satisfy $P_j(0, 0) \neq 0, j = 1, \dots, k$.

He considers a small polynomial perturbation $\omega_\epsilon = M_\epsilon \frac{dH_\epsilon}{H_\epsilon}$

$$\omega_{\epsilon, \varepsilon} = \omega_\epsilon + \varepsilon \eta, \quad \eta = Rdx + Sdy, \quad R, S \in \mathbb{R}[x, y].$$

The linear part in perturbation parameter ε of the Poincaré first return map is given by the pseudo-Abelian integrals

$$I(\epsilon, h) = \int_{\gamma(\epsilon, h)} \frac{\eta}{M_\epsilon}, \gamma(\epsilon, h) \subset H_\epsilon^{-1}(h).$$

Under the above genericity assumptions, Bobieński proves the existence of a local upper bound for the number of zeros of corresponding pseudo-Abelian integrals $I(\epsilon, h)$. However, his study does not give the existence of a uniform bound in a *full* neighborhood of the parameter space (ϵ, h) . The precise sense is clear after blow-up. Bobieński's argument works well when one is studying the integral along cycles contained in a neighborhood of the big polycycle $\delta = \delta_{01} \sqcup \delta_{02} \sqcup \delta_{03} \sqcup \delta_- \sqcup \delta_+ \sqcup \delta_3 \sqcup \dots \sqcup \delta_k$, see Figure 2. It corresponds to a sector in the (ϵ, h) -space. However, in order to have a study in a full neighborhood of $(0, 0)$ in the product space (ϵ, h) , one must study also cycles landing on the exceptional level on a polycycle made of the same polycycle in the equatorial plane, but completed by any one of the continuous family of curves $t = \frac{\epsilon^{\alpha+2}}{h}$ joining two saddles p_+ and p_- , see Figure 2. The study of the cycles in this sector is not done in Bobieński's paper.

To complete the proof, which is the main result of this present paper, we assume that the perturbative one-form η vanishes to the order ≥ 4 at $(x, y) = (0, 0)$ (technical condition), but our study covers a full neighborhood of the polycycle in the product space with space of parameters. Also, in this paper Darboux first integral is more general, i.e. $\epsilon_1 \neq \epsilon_2$. We prove the main result in full generality by blowing-up the whole family \mathcal{F}_λ and subsequently carefully piece-wise investigating the result combining Petrov's technique [10], general Gabrielov type results and topological methods.

4. RECTIFYING OF DARBOUX FIRST INTEGRAL

Let us establish a local normal form near the triple point $(0, 0, 0)$ for the unfolding of the degenerate polycycle $P_0 \dots P_k = 0$.

Proposition 4.1. *Under the above assumptions $\mathbf{A}_2, \mathbf{A}_3$, there exists a local analytic coordinate system (x, y, λ) at $(0, 0, 0)$ such that H_λ takes the form*

$$H_\lambda = (x - \lambda)^\epsilon (y - x)^{\epsilon+} (y + x)^{\epsilon-} \Delta, \tag{3}$$

where Δ is an analytic unity function $\Delta(0, 0, 0) \neq 0$.

Proof. There exists an analytic coordinate system (x, y) at $(0, 0)$ such that $P_1(x, y) = y\Delta_1, P_2(x, y) = x\Delta_2$ and $\prod_{i=3}^k P_i^{\epsilon_i} = \Delta_3$, where $\Delta_1, \Delta_2, \Delta_3$ are unities. In these coordinate and by Weierstrass preparation theorem we have $P_\lambda = (x - f(y, \lambda))\Delta_4$ where Δ_4 is a unit, $\frac{\partial f}{\partial \lambda}(0, 0) \neq 0$

and $\frac{\partial f}{\partial y}(0,0) \neq 0$. A second application of Weierstrass preparation theorem allows us to write $f(y, \lambda) = (y + g_0(\lambda))\Delta_5$, where Δ_5 is a unity function and $\frac{\partial g_0}{\partial \lambda}(0) \neq 0$. Now we put $\tilde{x} = \frac{x}{\Delta_5}$. Then

$$\tilde{x}\Delta_5 + (y + g_0(\lambda))\Delta_5 = (\tilde{x} - y - g_0(\lambda))\Delta_5.$$

Finally, $P_\lambda = (\tilde{x} - y - \tilde{\lambda})\Delta_4\Delta_5$, where $\tilde{\lambda} = g_0(\lambda)$. The normal form (3) can be obtained by a linear rotation on (\tilde{x}, y) . \square

5. DARBOUX INTEGRABLE FOLIATION

Consider two Darboux integrable foliations of dimension two in dimension three space with coordinates (x, y, λ)

$$\mathcal{F}_1 = \left\{ M_\lambda \frac{dH_\lambda}{H_\lambda} = 0 \right\}, \quad \mathcal{F}_2 = \{d\lambda = 0\}.$$

Let $\mathcal{F} = \{M_\lambda \frac{dH_\lambda}{H_\lambda} \wedge d\lambda = 0\}$ be the foliation of dimension one in a space of dimension three with coordinates (x, y, λ) which is given by the intersection of the leaves of \mathcal{F}_1 and \mathcal{F}_2 . This foliation has a non-elementary singularity at the origin $(0, 0, 0)$ which is the triple point. To reduce this singularity, we make the blowing-up of the triple point of the family in the product space (x, y, λ) of phase and parameter spaces. The family blowing-ups were introduced by Denkowska and Roussarie in [5].

5.1. Blowing-up the triple point. The blowing up σ with center at the origin (the triple point) is the projection onto \mathbb{C}^3 of a space W that is obtained by replacing the origin by the projective space $\mathbb{C}\mathbb{P}^2$ of all lines through the origin:

$$W = \{(p, q) \in \mathbb{C}^3 \times \mathbb{C}\mathbb{P}^2 : p \in q\}$$

and $\sigma : W \rightarrow \mathbb{C}^3$ is defined by $\sigma(p, q) = p$. Outside the origin, a point p belongs to a unique line q , but $\sigma^{-1}(0) = \mathbb{C}\mathbb{P}^2$ which is called the exceptional divisor. If we write p in terms of the affine coordinates $p = (p_1, p_2, p_3)$, and q in the corresponding homogeneous coordinates $q = [q_1, q_2, q_3]$, then the relation $p \in q$ translates into the system of equations $p_i q_j = p_j q_i$, for $i, j = 1, 2, 3$.

The projective space $\mathbb{C}\mathbb{P}^2$ is covered by three canonical charts: $W_1 = \{x \neq 0\}$ with coordinates (Y_1, E_1) , $W_2 = \{y \neq 0\}$ with coordinates (X_2, E_2) and $W_3 = \{\lambda \neq 0\}$ with coordinates (X_3, Y_3) . W_1, W_2 and W_3 define canonical charts on W , with coordinates $(X_1, Y_1, E_1), (X_2, Y_2, E_2)$ and (X_3, Y_3, E_3) respectively. In these coordinates, σ is given by the formulas:

$$\sigma_1 = \sigma|_{W_1} : x = X_1 \quad y = X_1 Y_1 \quad \lambda = E_1 X_1, \quad (4)$$

$$\sigma_2 = \sigma|_{W_2} : x = X_2 Y_2 \quad y = Y_2 \quad \lambda = E_2 Y_2, \quad (5)$$

$$\sigma_3 = \sigma|_{W_3} : x = X_3 E_3 \quad y = Y_3 E_3 \quad \lambda = E_3. \quad (6)$$

We apply the blowing-up σ to the one-dimensional foliation \mathcal{F} on the three-dimensional space with coordinates (x, y, λ) given by intersection of $M_\lambda \frac{dH_\lambda}{H_\lambda} = 0$ and $d\lambda = 0$. Let $\sigma^{-1}\mathcal{F}$ be the lift of the foliation \mathcal{F} to the complement of the exceptional divisor $\mathbb{C}\mathbb{P}^2$.

Proposition 5.1. *This foliation $\sigma^{-1}\mathcal{F}$ extends in a unique way to a holomorphic singular foliation $\sigma^*\mathcal{F}$ on W which we call the blow-up of the original dimension-one foliation \mathcal{F} by the map σ . The foliation $\sigma^*\mathcal{F}$ is regular outside of the preimage of the hypersurface $\{H(x, y, \lambda) = 0, \lambda = 0\}$.*

5.1.1. *Singularities of $\sigma^*\mathcal{F}$.* The strict transform of the period annulus D lies completely within the chart W_1 . Then, we concentrate our study uniquely on this chart. Let $\sigma_1^*\mathcal{F}$ be the restriction of the blown-up foliation $\sigma^*\mathcal{F}$ to the chart W_1 . We have σ is a biholomorphism outside $\mathbb{C}\mathbb{P}^2$ (exceptional divisor), all singularities of $\sigma_1^*\mathcal{F}$ on $W_1 \setminus \{X_1 = 0\}$ correspond to singularities of \mathcal{F} . Thus, it suffices to compute the singularities of $\sigma_1^*\mathcal{F}$ on the exceptional divisor $\{X_1 = 0\}$. Explicitly, near the exceptional divisor $\{X_1 = 0\}$, the blown-up foliation $\sigma_1^*\mathcal{F}$ is given by two first integrals $\lambda = X_1 E_1$ and $\frac{\lambda^a}{h} = G$, where

$$G = E_1^a(1 - E_1)^{-\epsilon}(Y_1 - 1)^{-\epsilon_+}(Y_1 + 1)^{-\epsilon_-} \tilde{\Delta}^{-1},$$

$\tilde{\Delta}$ is unit of the form $\tilde{\Delta} = c + X_1 f$, f is a holomorphic function and $a = \epsilon + \epsilon_+ + \epsilon_-$. Consider the two-dimensional square $Q \subset \mathbb{C}\mathbb{P}^2$ with vertices p_+, p_-, q_+ and q_- . All levels curves $\{G = \frac{\lambda^a}{h}\}$ inside Q correspond to values of $\frac{\lambda^a}{h} \in [0, +\infty]$.

Proposition 5.2. *The singularities of $\sigma_1^*\mathcal{F}$ on the exceptional divisor $\mathbb{C}\mathbb{P}^2$ are located at the points $p_+ = (0, 1, 0)$, $p_- = (0, -1, 0)$, $q_+ = (0, 1, 1)$ and $q_- = (0, -1, 1)$. All these singular points are linearisable saddles, with eigenvalues $\mu_+ = (\epsilon_+, -a, -\epsilon_-)$, $\mu_- = (-\epsilon_-, a, \epsilon_-)$, $\nu_+ = (0, -\epsilon, \epsilon_+)$ and $\nu_- = (0, -\epsilon, \epsilon_-)$ respectively.*

Proof. Let us compute the eigenvalues at p_+, p_-, q_+ and q_- . Near p_+ the foliation $\sigma_1^*\mathcal{F}$ is given by the two first integrals $h = X^a Y^{\epsilon_+}$ and $\lambda = X E$ (we make a convenient variables change). By Hartman-Grobman theorem the vector field generating the foliation $\sigma_1^*\mathcal{F}$ is given by

$$\mathbf{X}(X, Y, E) = \mu_1^+ X \frac{\partial}{\partial X} + \mu_2^+ Y \frac{\partial}{\partial Y} + \mu_3^+ E \frac{\partial}{\partial E},$$

such that the vector $\langle (\mu_1^+, \mu_2^+, \mu_3^+), (a, \epsilon_+, 0) \rangle = 0$ and $\langle (\mu_1^+, \mu_2^+, \mu_3^+), (1, 0, 1) \rangle = 0$. By short computation, we obtain

$$\mathbf{X}(X, Y, E) = \epsilon_+ X \frac{\partial}{\partial X} - a Y \frac{\partial}{\partial Y} - \epsilon_+ E \frac{\partial}{\partial E}.$$

Similar computation shows that there are local coordinates near q_+ in which the vector field generating the foliation is given by

$$\mathbf{Y}(X, Y, E) = -\epsilon Y \frac{\partial}{\partial Y} + \epsilon_+ E \frac{\partial}{\partial E}.$$

□

6. PROOF OF THEOREM 2.1

Let us fix some useful notations. Let $t = \frac{\lambda^a}{h}$, where $a = \epsilon + \epsilon_- + \epsilon_+$ and $Q \subset \mathbb{C}\mathbb{P}^2$ is the two-dimensional square with vertices p_+, p_-, q_+ and q_- . All levels curves $\{G = t\}$ inside Q correspond to values of $t \in [0, +\infty]$, where

$$G = E_1^a(1 - E_1)^{-\epsilon}(Y_1 - 1)^{-\epsilon_+}(Y_1 + 1)^{-\epsilon_-} \tilde{\Delta}^{-1}.$$

6.1. Polycycles, relative cycles and normal form. The important advantage of making the blowing-up σ is to obtain a family of hyperbolic polycycles, i.e. at each intersection of two consecutive curves we have a saddle point. We consider the family of hyperbolic polycycles δ

$$\delta = (\sigma_1^{-1}(\gamma(0, 0) \setminus (0, 0, 0)) \cup (Q \cap \{G = t\}))^{\mathbb{R}}, t \in [0, +\infty], \quad (7)$$

where $(\dots)^{\mathbb{R}}$ denotes the real part of a complex analytic set.

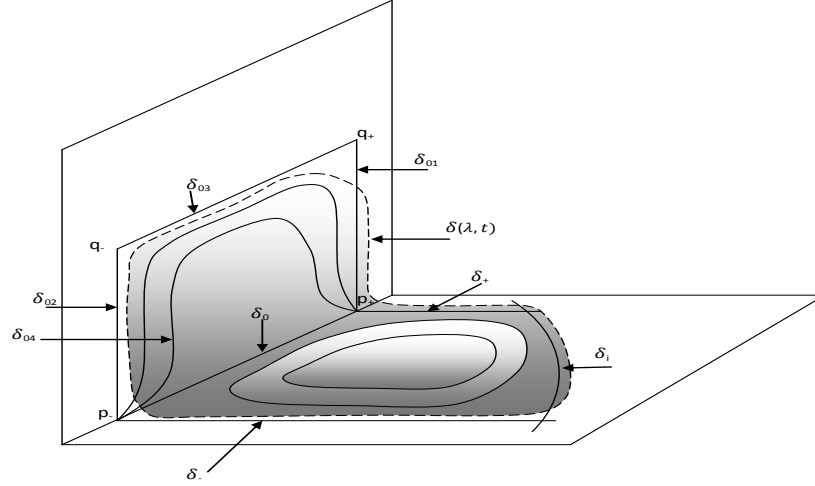

FIGURE 2. The foliation $\sigma_1^* \mathcal{F}$

6.1.1. *Polycycles.* Let δ_0 (edge) be the real part of the complex analytic set $\{X_1 = E_1 = 0\}$ joining two saddles p_- and p_+ , δ_{01} be the real part of the complex analytic set $\{X_1 = 0, Y_1 = 1\}$ joining the two saddles p_+ and q_+ , δ_{02} be the real part of complex analytic set $\{X_1 = 0, Y_1 = -1\}$ joining two saddles p_- and q_- , δ_{03} be the real part of complex analytic set $\{X_1 = E_1 = 0\}$ joining two saddles q_- and q_+ , δ_{04} be the real part of complex analytic set $\{X_1 = 0, G = t\}$ joining two saddles p_- and p_+ , δ_+ be the real part of the complex analytic set $\{Y_1 = 1, E_1 = 0\}$ joining two saddles p_1 and p_3 , δ_- be the real part of the complex analytic set $\{Y_1 = -1, E_1 = 0\}$ joining the two saddles p_- and p_k and finally let δ_i be the real part of the complex analytic set $\{\sigma_1^* P_i = 0, E_1 = 0\}$, $i = 3, \dots, k$ joining the two saddles p_m and p_n -see Figure 2.

Let $0 \leq m < M$. Then, we can decompose the family of hyperbolic polycycles δ as follows:

- (1) If $t \in [0, m[$, we have $\delta = \delta_0 \sqcup \delta_- \sqcup \delta_+ \sqcup \delta_3 \sqcup \dots \sqcup \delta_k$.

- (2) If $t \in [\frac{m}{2}, 2M]$, we have $\delta = \delta_{04} \sqcup \delta_- \sqcup \delta_+ \sqcup \delta_3 \sqcup \cdots \sqcup \delta_k$;
(3) If $t \in [M, +\infty]$, we have $\delta = \delta_{01} \sqcup \delta_{02} \sqcup \delta_{03} \sqcup \delta_- \sqcup \delta_+ \sqcup \delta_3 \sqcup \cdots \sqcup \delta_k$.

6.1.2. *Relative cycles.* Let p_1, \dots, p_k be the saddles points of the foliation $\sigma_1^* \mathcal{F}$ which lie on the polycycle δ . Let $\delta' = \delta \setminus \{p_1, \dots, p_k\}$. Choose a family of analytic transversals (of complex dimension two) Σ_x , through each point x in δ' . We can define a relative cycle γ (the part of the cycle $\delta(\lambda, t)$) by a initial condition (starting point x) and a end point $y = \gamma \cap \Sigma_y$ which is going from Σ_x . Concretly, we consider the relative cycles $\delta_0(\lambda, t)$ corresponding to the edge δ_0 , $\delta_{01}(\lambda, t)$ corresponding to the edge δ_{01} , $\delta_{02}(\lambda, t)$ corresponding to the edge δ_{02} , $\delta_{03}(\lambda, t)$ corresponding to the edge δ_{03} , $\delta_{04}(\lambda, t)$ corresponding to the edge δ_{04} , $\delta_+(\lambda, t)$ corresponding to the edge δ_+ , the relative cycle $\delta_-(\lambda, t)$ corresponding to the edge δ_- and the relative cycles $\delta_i(\lambda, t)$ corresponding to the edge $\delta_i, i = 3, \dots, k$ - see Figure 3.

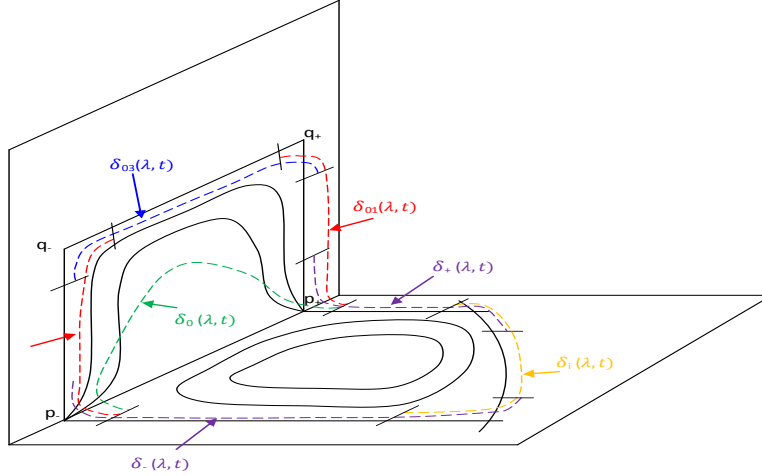

FIGURE 3. The relative cycles

6.1.3. *Normal form coordinates near the polycycles.* Now we obtain normal forms in neighborhoods of each edge of polycycles

Proposition 6.1. (1) *There exist a local chart $(U_0, (X, Y, E)) \subset W$ defined in a neighborhood of δ_0 such that the blown-up foliation $\sigma_1^* \mathcal{F}$ is given by two first integrals*

$$\lambda = XE, \quad t = (Y - 1)^{-\epsilon+} (Y + 1)^{-\epsilon+} E^a.$$

(2) *There exist a local chart $(U_{01}, (X, Y, E)) \subset W$ defined in a neighborhood of δ_{01} such that the blown-up foliation $\sigma_1^* \mathcal{F}$ is given by two first integrals*

$$\lambda = XE, \quad t = E^a (1 - E)^{-\epsilon} Y^{-\epsilon+}.$$

(3) *There exist a local chart $(U_{02}, (X, Y, E)) \subset W$ defined in a neighborhood of δ_{02} such that the blown-up foliation $\sigma_1^* \mathcal{F}$ is given by two first integrals*

$$\lambda = XE, \quad t = E^a (1 - E)^{-\epsilon} Y^{-\epsilon-}.$$

(4) *There exist a local chart $(U_{03}, (X, Y, E)) \subset W$ defined in a neighborhood of δ_{03} such that the blown-up foliation $\sigma_1^* \mathcal{F}$ is given by two first integrals*

$$\lambda = X, \quad t = E^{-\epsilon} (Y - 1)^{-\epsilon+} (Y + 1)^{-\epsilon-}.$$

(5) *There exist a local chart $(U_+, (X, Y, E)) \subset W$ defined in a neighborhood of δ_+ such that the blown-up foliation $\sigma_1^* \mathcal{F}$ is given by two first integrals*

$$\lambda = XE, \quad t = Y^{\epsilon+} (1 + X)^{\epsilon_i} E^a.$$

(6) *There exist a local chart $(U_-, (X, Y, E)) \subset W$ defined in a neighborhood of δ_- such that the blown-up foliation $\sigma_1^* \mathcal{F}$ is given by two first integrals*

$$\lambda = XE, \quad t = Y^{\epsilon-} (1 + X)^{\epsilon_i} E^a.$$

(7) *There exist a local chart $(U_i, (X, Y, E)) \subset W, i = 3, \dots, k$, defined in a neighborhood of δ_i such that the blown-up foliation $\sigma_1^* \mathcal{F}$ is given by two first integrals*

$$\lambda = E, \quad t = Y^{\epsilon_i} (1 - X)^{\epsilon_i+1} X^{\epsilon_i-1} = t.$$

6.2. Proof of Theorem 2.1. Let δ be a polycycle. Let $\delta(\lambda, t) = \sigma^{-1}(\gamma(\lambda, h)) \subset W$ (dashed cycle, see Figure 2) be the pull-back of the cycle $\gamma(\lambda, h)$ by the blowing-up map and δ be its corresponding polycycle. We define the integral

$$J(\lambda, t) = \int_{\delta(\lambda, t)} \sigma_1^* \frac{\eta}{M_\lambda}. \quad (8)$$

This integral is considered as the pull-back of the pseudo-abelian integrals $I(\lambda, h)$ by the blowing-up σ_1 , i.e. $J(\lambda, t) = \sigma_1^* I(\lambda, t)$. The proof of Theorem 2.1 is reduced to the proof of the following theorem

Theorem 6.2. *Let $\varepsilon > 0$ be sufficiently small. Then, for all $|\lambda| < \varepsilon$ the number $\#\{t \in [0, +\infty] : J(\lambda, t) = 0\}$ is locally bounded.*

6.2.1. *Variation operator.* Firstly, let us recall some definitions, notation and general results. They will be useful later.

Definition 6.3. *Given any multivalued function J defined in a neighborhood of the origin in \mathbb{C} i.e. a holomorphic function defined on the universal covering $\widetilde{\mathbb{C}^*}$ of \mathbb{C}^* . We define the rescaled monodromy as*

$$\mathcal{M}on_{(t,\alpha)}J(t) = J(te^{i\pi\alpha}).$$

The variation is given as the difference between the counterclockwise and clockwise continuation

$$\begin{aligned}\mathcal{V}ar_{(t,\alpha)}J(t) &= \mathcal{M}on_{(t,\alpha)}J(t) - \mathcal{M}on_{(t,-\alpha)}J(t) \\ &= J(te^{i\pi\alpha}) - J(te^{-i\pi\alpha}).\end{aligned}$$

Definition 6.4. *Let J be a multivalued function in two variables λ and t defined in universal covering $\mathbb{C}^2 \setminus \{\lambda t = 0\}$ of $\mathbb{C}^2 \setminus \{\lambda t = 0\}$. We define the mixed variation as*

$$\begin{aligned}\mathcal{V}ar_{(\lambda,\beta)} \circ \mathcal{V}ar_{(t,\alpha)}J(\lambda, t) &= \mathcal{V}ar_{(\lambda,\beta)}(J(\lambda, te^{i\pi\alpha}) - J(\lambda, te^{-i\pi\alpha})) = \\ &= J(\lambda e^{i\pi\beta}, te^{i\pi\alpha}) - J(\lambda e^{-i\pi\beta}, te^{i\pi\alpha}) - J(\lambda e^{i\pi\beta}, te^{-i\pi\alpha}) + J(\lambda e^{-i\pi\beta}, te^{-i\pi\alpha}).\end{aligned}$$

Lemma 6.5. *The variations $\mathcal{V}ar_{(\lambda,\beta)}$ and $\mathcal{V}ar_{(t,\alpha)}$ commute*

$$\mathcal{V}ar_{(\lambda,\beta)} \circ \mathcal{V}ar_{(t,\alpha)} = \mathcal{V}ar_{(t,\alpha)} \circ \mathcal{V}ar_{(\lambda,\beta)}.$$

Proof. The proof is a consequence of the monodromy theorem which says that: If γ_1, γ_2 are homotopic paths in $\mathbb{C}^2 \setminus \{\lambda t = 0\}$, then $\psi_{\gamma_1} = \psi_{\gamma_2}$ where $\psi_{\gamma_1} = \mathcal{M}on_{\gamma_1}\psi$ and $\psi_{\gamma_2} = \mathcal{M}on_{\gamma_2}\psi$. We consider

$$\begin{aligned}\gamma_1(\theta, \phi) &= (\lambda(\theta, \phi), t(\theta, \phi)) = (\lambda, te^{i\theta})_{\theta \in [0, \alpha]} \sqcup (\lambda e^{i\phi}, te^{i\alpha})_{\phi \in [0, \beta]}, \\ \gamma_2(\theta, \phi) &= (\lambda(\theta, \phi), t(\theta, \phi)) = (\lambda e^{i\phi}, t)_{\phi \in [0, \beta]} \sqcup (\lambda e^{i\beta}, te^{i\theta})_{\theta \in [0, \alpha]}.\end{aligned}$$

The paths γ_1 and γ_2 are homotopic and this implies that $\psi(\lambda e^{i\alpha\pi}, te^{i\beta\pi})$ can be defined either as ψ_{γ_1} or ψ_{γ_2} . The same argument holds for the other germs $\psi(\lambda e^{-i\alpha\pi}, te^{i\beta\pi})$, $\psi(\lambda e^{i\alpha\pi}, te^{-i\beta\pi})$ and $\psi(\lambda e^{-i\alpha\pi}, te^{-i\beta\pi})$. \square

6.2.2. *Analytic properties.* The integral $J(\lambda, t)$ has an analytic extension to the complex argument t (resp λ). This is a multivalued function with unique branch point $t = 0$ (resp $\lambda = 0$). As in [2], the key of the proof of Theorem 6.2 is the following.

Proposition 6.6. *The integral $J(\lambda, t)$ satisfies the following iterated rescaled variations equation*

$$\mathcal{V}ar_{(t,\alpha_1)} \circ \dots \circ \mathcal{V}ar_{(t,\alpha_k)}J(\lambda, t) = 0. \quad (9)$$

where α_i are polynomials functions in $\epsilon, \epsilon_+, \epsilon_-, \epsilon_3, \dots, \epsilon_k$.

Proof. Let us fix λ . We choose a hyperbolic polycycle δ of the family (6.1). As in [2], using the different charts of Proposition 6.1 and partition of unity multiplying the blown-up one form $\sigma_1^* \frac{\eta}{M_\lambda}$ we can consider semilocal problem with a relative cycle $\delta_i(\lambda, t)$ (part of cycle $\delta(\lambda, t)$) close to one edge (i -th edge) of the polycycle. Let $\delta_i^{\mathbb{C}}$ be the complexification of the real i -th edge joining the singular points p_{i-1}, p_{i+1} (saddles).

(1) If $\alpha_{i-1} \neq \alpha_{i+1}$ (generic case), we have

$$\mathcal{V}ar_{(t,\alpha_{i-1})} \circ \mathcal{V}ar_{(t,\alpha_{i+1})} \delta_i(\lambda, t) = \widetilde{[\gamma_{i-1}, \gamma_{i+1}]}, \quad (10)$$

where $\widetilde{[\gamma_{i-1}, \gamma_{i+1}]}$ is a complex (closed) cycle obtained as a lift of the commutator $[\gamma_{i-1}, \gamma_{i+1}]$, where γ_{i-1} and γ_{i+1} are paths in $\delta_i^{\mathbb{C}} \setminus \{p_{i-1}, p_{i+1}\}$ turning once counterclockwise around p_{i-1} and p_{i+1} . This lifting $\widetilde{[\gamma_{i-1}, \gamma_{i+1}]}$ vanishes by making third variation, i.e.

$$\mathcal{V}ar_{(t,\alpha_i)} \widetilde{[\gamma_{i-1}, \gamma_{i+1}]} \equiv 0. \quad (11)$$

(2) If $\alpha_{i-1} = \alpha_{i+1}$ (resonant case), we have

$$\mathcal{V}ar_{(t,\alpha_{i-1})} \delta_i(\lambda, t) = \widetilde{\gamma_{i-1} \gamma_{i+1}^{-1}}, \quad (12)$$

where $\widetilde{\gamma_{i-1} \gamma_{i+1}^{-1}}$ is a complex (closed) cycle obtained as a lift of the figure eight loop $\gamma_{i-1} \gamma_{i+1}^{-1}$. This lifting $\widetilde{\gamma_{i-1} \gamma_{i+1}^{-1}}$ vanishes by making second variation, i.e.

$$\mathcal{V}ar_{(t,\alpha_i)} \widetilde{\gamma_{i-1} \gamma_{i+1}^{-1}} \equiv 0. \quad (13)$$

Finally, the variations commute so

$$\mathcal{V}ar_{(t,\alpha_1)} \circ \dots \circ \mathcal{V}ar_{(t,\alpha_k)} \delta(\lambda, t) = 0. \quad (14)$$

This argument is independent of the choice of polycycle, i.e. it holds for any hyperbolic polycycle δ of family (7). \square

Proposition 6.7. *The rescaled variation with respect to λ of the integral $J(\lambda, t)$ is an integral of the form $\sigma_1^* \frac{\eta}{M_\lambda}$ along the figure eight loop*

$$\mathcal{V}ar_{(\lambda,1)} J(\lambda, t) = \int_{\text{figure eight loop}} \sigma_1^* \frac{\eta}{M_\lambda}. \quad (15)$$

Proof. In the local chart $(U_0, (X, Y, E))$ of Proposition 6.1, the blown-up foliation $\sigma_1^* \mathcal{F}$ is given by the two first integrals $\lambda = XE$ and $t = E^a (Y-1)^{-\epsilon_+} (Y+1)^{-\epsilon_-}$. Let γ_+ and γ_- be two paths in $Y^{\mathbb{C}}$ turning counterclockwise around p_+ and p_- which are parametrized by

$$\rho_{\pm} : \theta \in [0, 2\pi] \mapsto \begin{cases} X(\theta, \lambda, t) \\ Y(\theta) = \pm 1 + \varepsilon e^{i\theta} \\ E(\theta, \lambda, t) \end{cases}.$$

Then, we have

$$F_{\pm}(\lambda, t) = \int_{\gamma_{\pm}} \sigma_1^* \frac{\eta}{M_\lambda} = \int_0^{2\pi} \rho_{\pm}^* \sigma_1^* \frac{\eta}{M_\lambda} d\theta.$$

Also, we define two functions

$$F_1(\lambda, t) = \int_{\ell_-} \sigma_1^* \frac{\eta}{M_\lambda}, \quad F_2(\lambda, t) = \int_{\ell_+} \sigma_1^* \frac{\eta}{M_\lambda},$$

where $\ell_- = [1 - \varepsilon, -1 + \varepsilon]$ and $\ell_+ = [-1 + \varepsilon, 1 - \varepsilon]$ (segments). So, we obtain

$$\mathcal{V}ar_{(\lambda,1)} J(\lambda, t) = F_-(\lambda, t) + F_2(\lambda, t) + F_+(\lambda, t) + F_1(\lambda, t) = \int_{\widetilde{\gamma_+ \ell_- \gamma_- \ell_+}} \sigma_1^* \frac{\eta}{M_\lambda},$$

where $\widetilde{\gamma_+ \ell_- \gamma_- \ell_+}$ is a closed path obtained as a lift of the path $\gamma_+ \ell_- \gamma_- \ell_+$ which is contained in $Y^{\mathbb{C}}$ and homotopic to a figure eight loop. \square

Corollary 6.8. *Near the ramification point $\lambda = 0$, the function $J(\lambda, t)$ admits the expansion*

$$J(\lambda, t) = J_1(\lambda, t) + J_2(\lambda, t) \log \lambda, \quad (16)$$

where $J_1(\cdot, t)$ is meromorphic and $J_2(\lambda, t) = \mathcal{V}ar_{(\lambda, 1)} J(\lambda, t)$.

6.2.3. Proof of Theorem 6.2. The integral $J(\lambda, t) = \int_{\delta(\lambda, t)} \sigma_1^* \frac{\eta}{M\lambda}$ can be analytically continued to the universal cover $\mathbb{C}^2 \setminus \{\widetilde{\lambda t} = 0\}$ of $\mathbb{C}^2 \setminus \{\lambda t = 0\}$. To estimate the number of zeros of the integral $J(\lambda, t) = \int_{\delta(\lambda, t)} \sigma_1^* \frac{\eta}{M\lambda}$ we apply the argument principle.

Let us introduce some definitions which will be useful later.

Definition 6.9. *Let $f : \mathbb{R}^n \times \mathbb{R} \rightarrow \mathbb{R}$. We shall say that f is a logarithmico-analytic function (LA-function) of type ℓ in variable y if it has the following form*

$$f(x, y) = F(f_1(x, y), \dots, f_m(x, y), \log f_{m+1}(x, y), \dots, f_{m+r}(x, y)),$$

where F is a global sub-analytic function and f_i are a LA-functions of type $\ell - 1$ in y .

Definition 6.10. *A logarithmico-exponential function (LE-function) is a finite composition of global sub-analytic functions, exponentials and logarithms.*

Let $\partial\Omega$ be the boundary of a complex domain Ω which consists of a big circular arc $C_{R_1} = \{|t| = R_1, |\arg t| \leq \alpha\pi\}$, a two segments $C^{\pm} = \{r_1 \leq |t| \leq R_1, |\arg t| = \pm\alpha\pi\}$ and the small circular arc $C_{r_1} = \{|t| = r_1, |\arg t| \leq \alpha\pi\}$ -see Figure 4.

The argument principle says that

$$\#\{t \in \Omega : J(\lambda, t) = 0\} \leq \frac{1}{2\pi} \Delta \arg_{\partial\Omega} J = \frac{1}{2\pi} (\Delta \arg_{C_{R_1}} J + \Delta \arg_{C^{\pm}} J + \Delta \arg_{C_{r_1}} J).$$

- (1) *The boundedness of the increment of argument $\Delta \arg_{C_{R_1}} J$.* By Gabrielov's theorem [6], the increment of the argument $\Delta \arg_{C_{R_1}} J$ is uniformly bounded.
- (2) *The boundedness of the increment of argument $\Delta \arg_{C^{\pm}} J$.* Let $\alpha \in \{\alpha_1, \dots, \alpha_k\}$. We use Schwartz's principle

$$\operatorname{Im}(J(\lambda, \cdot))|_{C^{\pm}} = \mp 2i \mathcal{V}ar_{(t, \alpha)} J(\lambda, t).$$

So $\Delta \arg_{C^{\pm}} J \leq \#\{t : \operatorname{Im}(J(\lambda, \cdot)) = 0\} = \#\{t : \mathcal{V}ar_{(t, \alpha)} J(\lambda, t) = 0\}$. Moreover, the variations commute so

$$\begin{aligned} \mathcal{V}ar_{(t, \alpha_1)} \circ \dots \circ \mathcal{V}ar_{(t, \alpha)} \circ \dots \circ \mathcal{V}ar_{(t, \alpha_k)} J(\lambda, t) &= \\ \mathcal{V}ar_{(t, \alpha_1)} \circ \dots \circ \mathcal{V}ar_{(t, \alpha_k)} (\mathcal{V}ar_{(t, \alpha)} J(\lambda, t)) &= 0. \end{aligned}$$

Then, near the ramification point $t = 0$, the function $\mathcal{V}ar_{(t, \alpha)} J(\lambda, t)$ can be written as follows

$$\mathcal{V}ar_{(t, \alpha)} J(\lambda, t) = F(e^{\frac{\alpha_1}{\alpha} \log t}, \dots, e^{\frac{\alpha_k}{\alpha} \log t}, \log \lambda) \quad (17)$$

where F is a meromorphic function. The function $\mathcal{V}ar_{(t, \alpha)} J(\lambda, t)$ is a LA-function of type 1 in variable λ . Then, by Lion-Rolin preparation theorem [8] this function has the following form

$$\mathcal{V}ar_{(t, \alpha)} J(\lambda, t) = \lambda_0^{q_0} \lambda_1^{q_1} \mathbf{G}(t) \mathbf{U}(t, \lambda_0, \lambda_1), \quad \mathbf{U}(0, 0, 0) \neq 0 \quad (18)$$

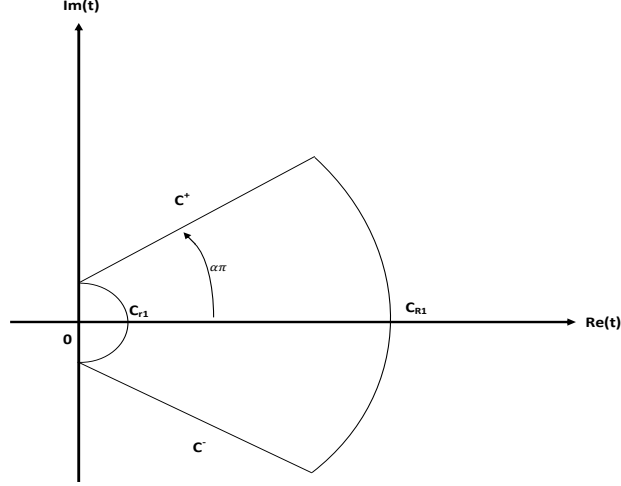

FIGURE 4. The contour $\partial\Omega$

with $\lambda_0 = \lambda - \theta_0(t)$, $\lambda_1 = \log \lambda_0 - \theta_1(t)$, where $\theta_0, \theta_1, \mathbf{G}$ and \mathbf{U} are LE-functions. As the number of zeros of a LE-function is bounded, so $\#\{t : \mathcal{V}ar_{(t,\alpha)} J(\lambda, t) = 0\}$ is uniformly bounded in λ .

- (3) *The boundedness of the increment of argument* $\Delta \arg_{C_{r_1}} J$. Consider the following functional space \mathcal{P}

$$\mathcal{P}(m, M; \alpha_1, \dots, \alpha_k; \lambda) := \left\{ \sum_{m \leq \alpha_j n \leq M} \sum_{0 \leq l \leq k} c_{jln}(\lambda) t^{\alpha_j n} \log^n t, c_{jln} \in \mathbb{C} \right\}.$$

Proposition 6.11. *We have $J_2(\lambda, t) = \mathcal{V}ar_{(\lambda,1)} J(\lambda, t) = \mathcal{O}(\lambda^\mu)$ uniformly in t , for some constant $\mu > 0$.*

Proof. Using the assumption \mathbf{A}_4 , we have $\sigma_1^* \frac{\eta}{M_\lambda}$ is $\mathcal{O}(X_1)$, we conclude that, for all closed paths of finite length $\ell < \infty$ contained in a sufficiently small neighborhood of the exceptional divisor $\{X_1 = 0\}$. Since $J_2(\lambda, t) = \mathcal{V}ar_{(\lambda,1)} J(\lambda, t)$ is the integrations of $\sigma_1^* \frac{\eta}{M_\lambda}$ over the lift of the eight figure on $\{X_1 = 0, G = t\}$, we conclude that $X_1 = \mathcal{O}(\lambda)$ on this lift and

$$J_2(\lambda, t) = \mathcal{V}ar_{(\lambda,1)} J(\lambda, t) = \lambda^\mu t^\nu (1 + \dots), \mu > 0.$$

□

Lemma 6.12. *The functions $J_1(\lambda, \cdot), J_2(\lambda, \cdot)$ are two meromorphic families in λ and satisfy the following rescaled variation equation with respect to t*

$$\mathcal{V}ar_{(t,\alpha_1)} \circ \dots \circ \mathcal{V}ar_{(t,\alpha_k)} J_i(\lambda, t) = 0, \quad i = 1, 2. \quad (19)$$

Then, there exists a family of meromorphic function $P_1(\lambda, \cdot), P_2(\lambda, \cdot) \in \mathcal{P}(\dots)$ such that

$$|J_i(\lambda, t) - P_i(\lambda, t)| \leq C|t|^M, \quad \text{uniformly in } \lambda, \quad i = 1, 2$$

and $J_2(\lambda, t) - P_2(\lambda, t) = \mathcal{O}(\lambda^\mu), \mu > 0$ uniformly in t and $(J_2(\lambda, t) - P_2(\lambda, t)) \log \lambda = \mathcal{O}(\lambda^\mu \log \lambda)$. Moreover $J(\lambda, t) \neq 0$. Then for sufficiently big M : $P_1(\lambda, t) + P_2(\lambda, t) \log \lambda \neq 0$.

Proof. Using the linearity of the variation operator $\mathcal{V}ar$, equations (9) and (16), we have

$$\mathcal{V}ar_{(t,\alpha_1)} \circ \dots \circ \mathcal{V}ar_{(t,\alpha_k)} J_i(\lambda, t) = 0, \quad i = 1, 2.$$

Lemma 4.8 from [2] yields that there exists an analytic (a priori meromorphic) families of functions $P_i(\lambda, \cdot) \in \mathcal{P}(\dots)$ such that $|J_i(\lambda, t) - P_i(\lambda, t)| \leq C|t|^M$, uniformly in λ . \square

To estimate the limit of the increment of argument $\Delta \arg_{C_{r_1}} J(\lambda, t)$ along the small circular arc C_{r_1} : $\lim_{r_1 \rightarrow 0} \Delta \arg_{C_{r_1}} J$, we investigate the leading term of $J(\lambda, t)$ at $t = 0$. By Lemma 6.12 we have $J_1(\lambda, t) + J_2(\lambda, t) \log \lambda - (P_1(\lambda, t) + P_2(\lambda, t) \log \lambda)$ is $\mathcal{O}(t^M)$ uniformly in λ . For each element of parameters space, we can choose the leading term P of $P_1(\lambda, t) + P_2(\lambda, t) \log \lambda$. By Gabrielov's theorem, the increment of argument of P is bounded.

ACKNOWLEDGMENTS

It is pleasure to thank Pavao Mardešić (Université de Bourgogne-Dijon) and Daniel Panazzolo (Université de Haute Alsace-Mulhouse) for their constants suport in this work.

REFERENCES

- [1] Bobieński, Marcin Pseudo-Abelian integrals along Darboux cycles *a codimension one case*. *J. Differential Equations* 246 (2009), no. 3, 1264-1273.
- [2] Bobieński, Marcin; Mardešić, Pavao *Pseudo-Abelian integrals along Darboux cycles*. *Proc. Lond. Math. Soc.* (3) 97 (2008), no. 3, 669-688.
- [3] Bobieński, Marcin; Mardešić, Pavao; Novikov, Dmitry *Pseudo-Abelian integrals: unfolding generic exponential*. *J. Differential Equations* 247 (2009), no. 12, 3357-3376.
- [4] Bobieński, Marcin; Mardešić, Pavao; Novikov, Dmitry *Pseudo-Abelian integrals on slow-fast Darboux systems*. *Ann. Inst. Fourier (Grenoble)*, 2013
- [5] Denkowska, Zofia; Roussarie, Robert; *A method of desingularization for analytic two-dimensional vector field families*. *Bol. Soc. Brasil. Mat. (N.S.)* 22 (1991), no. 1, 93-126.
- [6] Gabrièlov, A. M *Projections of semianalytic sets*. (Russian) *Funktsional. Anal. i Priložen.* 2 1968 no. 4, 18-30
- [7] Khovanskii, A, G. *Real analytic manifolds with property of finitness, and complex abelian integrals*, *Funktsional. Ana. i Priložen.* 18 (2) (1984) 40-50.
- [8] Lion, Jean Marie; Rolin, Jean Phillipe *Théorème de préparation pour les fonctions logarithmico-exponentielles*. *Annales de l'institut de Fourier*, tome 47, n3 (1997) p.859-884.
- [9] Novikov, Dmitry *On limit cycles appearing by polynomial perturbation of Darbouxian integrable systems*. *Geom. Funct. Anal.* 18 (2009), no. 5, 1750-1773.
- [10] Petrov, G. S. *On the nonoscillation of elliptic integrals*. (Russian) *Funktsional. Anal. i Priložen.* 31 (1997), no. 4, 47-51, 95; translation in *Funct. Anal. Appl.* 31 (1997), no. 4, 262-265 (1998).
- [11] Varchenko, A. N. *Estimation of the number of zeros of an abelian integral depending on a parameter, and limit cycles*. (Russian) *Funktsional. Anal. i Priložen.* 18 (1984), no. 2, 14-25.

UNIVERSITÉ DE BOURGOGNE, INSTITUT DE MATHÉMATIQUES DE BOURGOGNE, U.M.R. 5584 DU C.N.R.S.,
B.P. 47870, 21078 DIJON CEDEX - FRANCE.
E-mail address: aymenbraghtha@yahoo.fr