



**HAL**  
open science

## Direct Detection Differential Absorption LIDAR for Multi-Species Atmospheric Sensing in the 2- $\mu$ m Range

Erwan Cadiou, Jean-Baptiste Dherbecourt, Dominique Mammez, Guillaume Gorju, Myriam Raybaut, Jean-Michel Melkonian, Antoine Godard, Jacques Pelon, Michel Lefebvre

### ► To cite this version:

Erwan Cadiou, Jean-Baptiste Dherbecourt, Dominique Mammez, Guillaume Gorju, Myriam Raybaut, et al.. Direct Detection Differential Absorption LIDAR for Multi-Species Atmospheric Sensing in the 2- $\mu$ m Range. Laser Applications to Chemical, Security and Environmental Analysis 2016, Jul 2016, Heidelberg Germany. 10.1364/LACSEA.2016.LTh1G.5 . hal-01386710

**HAL Id: hal-01386710**

**<https://hal.science/hal-01386710v1>**

Submitted on 26 Oct 2016

**HAL** is a multi-disciplinary open access archive for the deposit and dissemination of scientific research documents, whether they are published or not. The documents may come from teaching and research institutions in France or abroad, or from public or private research centers.

L'archive ouverte pluridisciplinaire **HAL**, est destinée au dépôt et à la diffusion de documents scientifiques de niveau recherche, publiés ou non, émanant des établissements d'enseignement et de recherche français ou étrangers, des laboratoires publics ou privés.

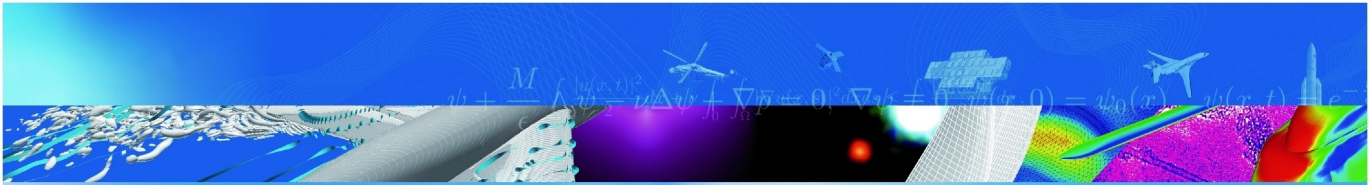

COMMUNICATION A CONGRES

**Direct detection differential  
absorption LIDAR for multi-species  
atmospheric sensing in  
the 2- $\mu\text{m}$  range**

E. Cadiou, J.-B. Dherbecourt, D. Mammez, G. Gorju,  
M. Raybaut, J.-M. Melkonian, A. Godard  
J. Pelon (LATMOS), M. Lefebvre

Imaging and Applied Optics, Optics and Photonics  
Congress

HEIDELBERG, ALLEMAGNE

25-28 juillet 2016

TP 2016-514

**70** 2016  
ans

**ONERA**

THE FRENCH AEROSPACE LAB



# Direct Detection Differential Absorption LIDAR for Multi-Species Atmospheric Sensing in the 2- $\mu$ m Range

Erwan Cadiou<sup>1,2</sup>, Jean-Baptiste Dherbecourt<sup>1</sup>, Dominique Mammez<sup>1,2</sup>, Guillaume Gorju<sup>1</sup>, Myriam Raybaut<sup>1</sup>, Jean-Michel Melkonian<sup>1</sup>, Antoine Godard<sup>1</sup>, Jacques Pelon<sup>3</sup>, Michel Lefebvre<sup>1</sup>

<sup>1</sup> ONERA, The French Aerospace Lab, Chemin de la Hunière, F-91761 Palaiseau cedex, France

<sup>2</sup> CNES, centre de Toulouse, 18 avenue Edouard Belin, F-31401 Toulouse cedex 9, France

<sup>3</sup> LATMOS, Université Pierre et Marie Curie, 4 Place Jussieu Paris, France

jean-baptiste.dherbecourt@onera.fr

**Abstract:** A direct detection atmospheric differential absorption lidar, based on a high energy optical parametric source at 2  $\mu$ m to address CO<sub>2</sub>, CH<sub>4</sub> and H<sub>2</sub>O, is presented. We report first experimental measurements on CO<sub>2</sub>.

**OCIS codes:** (280.0280) Remote sensing and sensors; (280.1910) DIAL, differential absorption lidar

## 1. Introduction

A better knowledge of atmospheric carbon dioxide, methane and water vapor is expected to improve the accuracy of existing models and to help anticipate climate change. In this context, several space-borne lidar missions are foreseen in the upcoming years to measure their concentration at a global scale, including MERLIN (CNES/DLR) for methane and ASCENDS (NASA) for carbon dioxide. The challenge of these instruments is to develop high energy sources which can emit at specific wavelengths to address the gas species of interest. In the 2  $\mu$ m spectral region, the major greenhouse gases present particularly well-suited absorption lines for space-borne applications which can be efficiently addressed by solid state laser technologies [1,2]. In this paper, we present a direct detection differential absorption lidar (DIAL) based on a high-energy parametric source whose tunability enables to target several species with a single instrument [3]. The system has been operated for ground-based long range measurements by collecting backscattered signal from aerosols and clouds with a direct detection receiver. First experimental concentration measurements have been obtained by targeting the R30 absorption line of CO<sub>2</sub> at 2051 nm [2]. Beside the air-borne and space-borne applications, such an instrument could be potentially implemented from ground to calibrate/validate passive or active space-borne gas measurements.

## 2. Experimental setup

The experimental setup depicted in Fig. 1 comprises a laser transmitter and a receiver telescope. The laser transmitter is based on a nested cavity optical parametric oscillator (NesCOPO), a specific architecture which ensures tunable single frequency emission without any injection seed [3]. It is followed by a high energy two-step optical parametric amplifier (OPA) including a periodically poled lithium niobate (PPLN) crystal and four bulk KTP crystals. The whole system is pumped at 30 Hz by a Nd:YAG Laser delivering 100 mJ energy pulses at 1064 nm. The oscillation buildup time of the NesCOPO is compensated by a 10 ns delay line inserted in the pump beam path

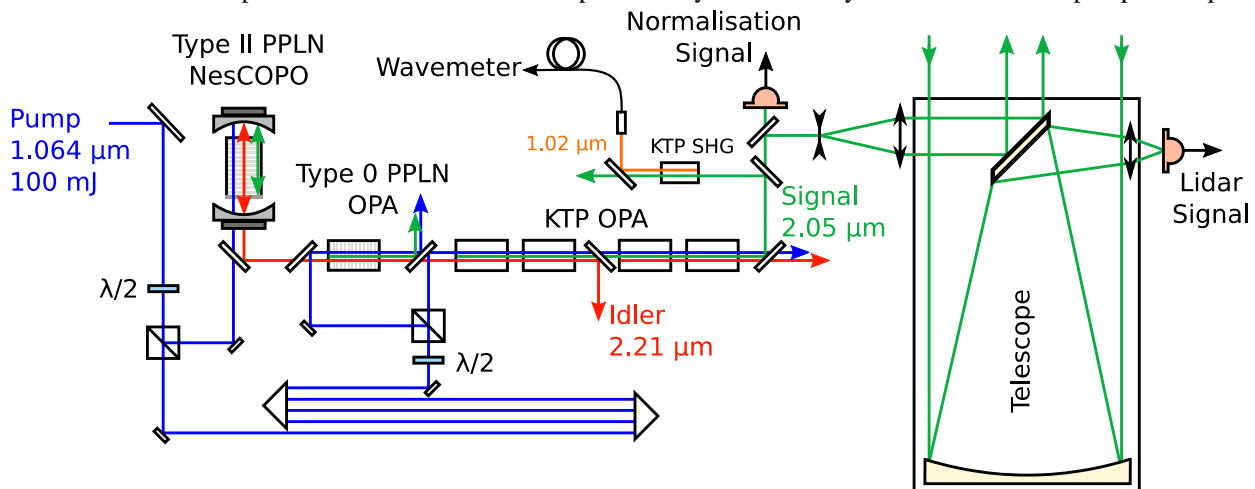

Fig. 1. Schematic diagram of the experimental setup

before the amplifiers. The emitter delivers 10 ns Fourier-transform limited pulses that are tunable between 1980 nm and 2100 nm. In order to perform the DIAL measurement, the emitted wavelength is switched pulse to pulse. For that purpose, pulse-to-pulse adjustment of the NesCOPO cavity length is carried out by use of piezoelectric transducers. In our lidar experiments, the available pulse energy for the transmitted signal wave in the atmosphere at 2051 nm was around 10 mJ.

In order to monitor the wavelength a small amount of energy is sampled from the output beam by use of a CaF<sub>2</sub> plate. It is then frequency doubled using second harmonic generation in a KTP crystal to match with the detection spectral range of a high precision wavemeter (WSU 10 of High Finesse operating up to 1.1  $\mu\text{m}$ ). A reference detector measures the energy leaked through a high-reflectivity deflecting mirror to normalize the backscattered lidar signal of each pulse and thus correct systematic errors on CO<sub>2</sub> concentration estimation caused by energy fluctuations between the ON and OFF wavelengths. Before transmission in the atmosphere, the divergence of the beam is reduced to 500  $\mu\text{rad}$  with a beam expander.

The lidar receiver consists of a Newton telescope which focuses the backscattered laser radiation on an InGaAs amplified photodiode. To increase the field of view of the telescope a short focal lens is placed in front of the detector. The resulting field of view of 800  $\mu\text{rad}$  is thus adapted to the transmitted laser beam divergence. Emission and reception axes overlap and are oriented at 45° from the vertical, which enables to reach the first layers of clouds. Both lidar and normalization signals are acquired with a 500 MHz sample-rate digitizer. Transmitter and receiver parameters are summarized in Table 1.

**Table 1** : Instrument parameters

Transmitter		Receiver	
Pulse energy	10 mJ	Telescope diameter	20 cm
Pulse duration	10 ns	Field of view	800 $\mu\text{rad}$
Repetition rate	30 Hz	Detector Type	InGaAs PIN
OFF-line wavelength	2050.963 nm	Detector diameter	300 $\mu\text{m}$
ON-line wavelength	2051.047 nm	Detector NEP	$3.10^{-12}$ W/ $\sqrt{\text{Hz}}$
Linewidth	< 60 MHz	Bandwidth	30 MHz
Divergence angle	500 $\mu\text{rad}$	Sampling rate	500 MHz

### 3. Results

Fig. 2(a) shows the received ON and OFF signals for a 4 minute acquisition time corresponding to the averaging of approximately 3600 couples of ON-OFF shots. The first detected peak comes from the diffusion on the transmitting optics. Aerosol backscattered signal is detected between 50 and 600 meters and cloud echoes are detected between 650 m and 950 m. Acquired traces are averaged and smoothed with a 15 MHz filter equivalent to a 10 meters spatial resolution. The temporal variations of the clouds signals are shown in false colors in Fig. 3. This representation enables to see the spatial coherence of the clouds passing in the line of sight of the lidar, and the periodic backscattered intensity due to pulse-to-pulse ON/OFF wavelength switches.

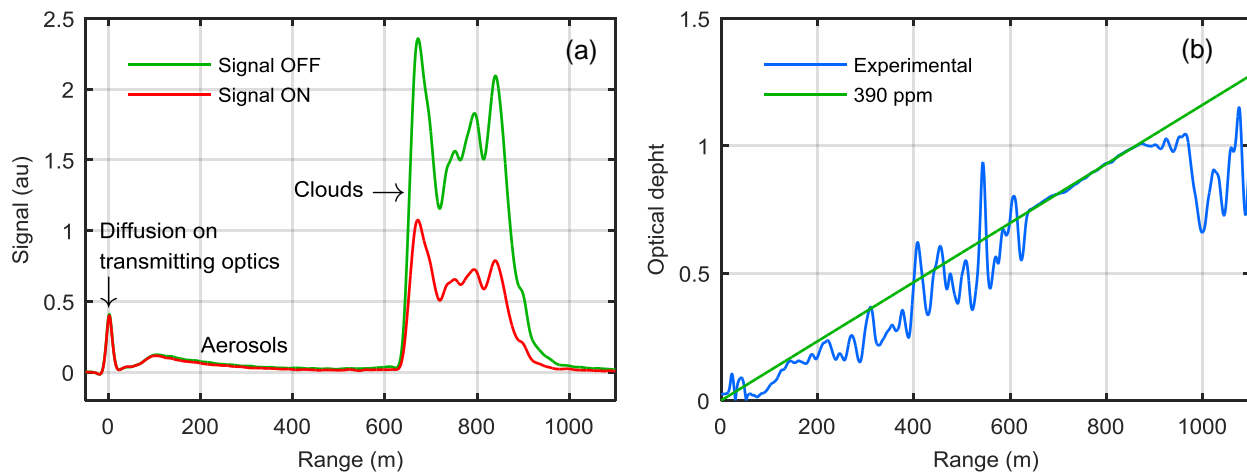

Fig. 2. (a) OFF-line and ON-line return signals. Averaging over 3600 shots and a 15 MHz numerical filtering have been applied to both signals. (b) Differential optical depths versus range for experimental data and for a theoretical homogeneous mixing ratio of 390 ppm.

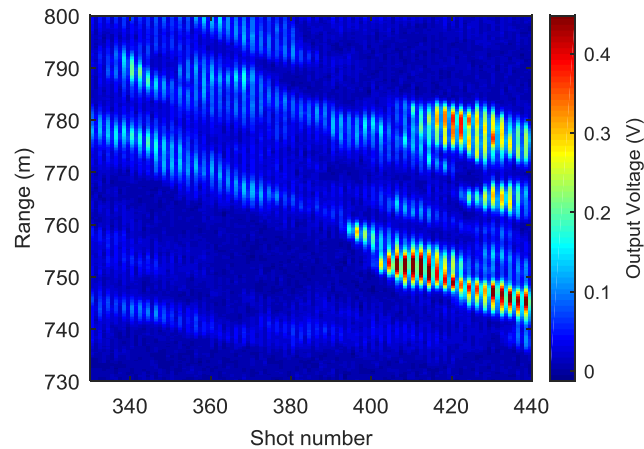

Fig. 3. Cloud backscattered signals before signal processing. At every shot, the transmitter switches between the OFF and the ON wavelengths. Couples of ON-OFF traces which exceed the digitizer dynamic (red) are not taken into account to retrieve the CO<sub>2</sub> concentration.

CO<sub>2</sub> cross section has been calculated using a Voigt profile and the Hitran database in order to retrieve the concentration of CO<sub>2</sub>. The optical depth derived from the lidar signals is shown in Fig. 1(b). In the clouds, the slope of the measured optical depth matches a uniform 390 ppm CO<sub>2</sub> average mixing ratio with a  $\pm 16$  ppm uncertainty. Further range-resolved experiments are currently carried out in order to validate the accuracy and increase the precision of carbon dioxide profiling across the whole line of sight. Complementary measurements targeting water vapor are also conducted in order to demonstrate the multi species detection ability of the system.

#### 4. Acknowledgements

This work is partially supported by the CNES Research and Technology program.

#### 5. References

- [1] T. F. Refaat, U. N. Singh, M. Petros, R. Remus, and J. Yu, "Self-calibration and laser energy monitor validations for a double-pulsed 2- $\mu$ m CO<sub>2</sub> integrated path differential absorption lidar application," *Appl. Opt.* **54**, 7240–7251 (2015).
- [2] G. Ehret, C. Kiemle, M. Wirth, A. Amediek, A. Fix, and S. Houweling, "Space-borne remote sensing of CO<sub>2</sub>, CH<sub>4</sub>, and N<sub>2</sub>O by integrated path differential absorption lidar: a sensitivity analysis," *Appl. Phys. B* **90**, 593–608 (2008).
- [3] J. Barrientos Barria, D. Mammez, E. Cadiou, J.-B. Dherbecourt, M. Raybaut, T. Schmid, A. Bresson, J.-M. Melkonian, A. Godard, J. Pelon, and M. Lefebvre, "Multispecies high-energy emitter for CO<sub>2</sub>, CH<sub>4</sub>, and H<sub>2</sub>O monitoring in the 2  $\mu$ m range," *Opt. Lett.*, **39**, 6719–6722 (2014).



