



**HAL**  
open science

# Low-energy spectrum of Toeplitz operators with a miniwell

Alix Deleporte

► **To cite this version:**

| Alix Deleporte. Low-energy spectrum of Toeplitz operators with a miniwell. 2017. hal-01383403v2

**HAL Id: hal-01383403**

**<https://hal.science/hal-01383403v2>**

Preprint submitted on 22 Sep 2017 (v2), last revised 7 Mar 2018 (v3)

**HAL** is a multi-disciplinary open access archive for the deposit and dissemination of scientific research documents, whether they are published or not. The documents may come from teaching and research institutions in France or abroad, or from public or private research centers.

L'archive ouverte pluridisciplinaire **HAL**, est destinée au dépôt et à la diffusion de documents scientifiques de niveau recherche, publiés ou non, émanant des établissements d'enseignement et de recherche français ou étrangers, des laboratoires publics ou privés.



Distributed under a Creative Commons Attribution 4.0 International License

# Low-energy spectrum of Toeplitz operators with a miniwell

Alix Deleporte\*

Université de Strasbourg, CNRS, IRMA UMR 7501, F-67000  
Strasbourg, France

September 22, 2017

## Abstract

In the semiclassical limit, it is well-known that the first eigenvector of a Toeplitz operator concentrates on the minimal set of the symbol. In this paper, we give a more precise criterion for concentration in the case where the minimal set of the symbol is a submanifold, in the spirit of the “miniwell condition” of Helffer-Sjöstrand.

## Contents

<b>1</b>	<b>Introduction</b>	<b>2</b>
1.1	Motivations . . . . .	2
1.2	Main results . . . . .	3
1.3	Outline . . . . .	4
<b>2</b>	<b>Toeplitz quantization</b>	<b>4</b>
2.1	The Szegő projector . . . . .	4
2.2	Toeplitz operators . . . . .	7
2.2.1	Toeplitz operators on $\mathbb{C}^n$ . . . . .	7
2.2.2	Toeplitz operators on compact manifolds . . . . .	7
2.3	Quantum maps . . . . .	9

---

\*deleporte@math.unistra.fr

<b>3</b>	<b>Resolvent estimates</b>	<b>9</b>
3.1	A cutting lemma . . . . .	9
3.2	Melin estimate . . . . .	11
3.3	Pseudo-locality of the resolvent . . . . .	12
<b>4</b>	<b>Proof of Theorem A</b>	<b>13</b>
4.1	Estimate of the first eigenvalue . . . . .	13
4.2	End of the proof . . . . .	13
<b>5</b>	<b>Reduction of the regular case</b>	<b>14</b>
5.1	A convenient chart . . . . .	14
5.2	Approximate eigenfunctions . . . . .	17
5.3	Spectral gap . . . . .	20
<b>6</b>	<b>Examples</b>	<b>21</b>
6.1	Crossing of submanifolds . . . . .	21
6.2	Frustrated spin systems . . . . .	23
6.2.1	Explain . . . . .	23
6.2.2	Description of the zero set . . . . .	23
6.2.3	Irregularity of the zero set . . . . .	25
6.2.4	Degeneracy for end-point triangles . . . . .	26

# 1 Introduction

## 1.1 Motivations

Let  $V$  a smooth positive function on a Riemannian manifold, with  $0 = \min(V)$ . If the operator  $-\Delta + V$  has compact resolvent, what can be said about a sequence of unit eigenvectors of  $-h\Delta + V$  with minimal eigenvalue, in the limit  $h \rightarrow 0$ ? It is well-known that this sequence is  $O(h^\infty)$  outside every neighbourhood of  $\{V = 0\}$ . More precisely, if  $\{V = 0\}$  is a submanifold, Helffer and Sjöstrand [5] proposed a more precise criterion for localization, based on the Hessian matrix of  $V$  on the submanifold. If this matrix is “minimal” at only one point, in a non-degenerate way (the miniwell condition), then, as  $h \rightarrow 0$ , the lowest energy eigenfunction is  $O(h^{-\infty})$  outside any fixed neighbourhood of this point. An example of this is the Schrödinger operator on  $L^2(\mathbb{R}^2)$  with potential:

$$V(x_1, x_2) = (x_1^2 + x_2^2 - 1)^2(1 + (x_1 + 1)^2),$$

which vanishes on the unit circle but which is “smaller” near  $(-1, 0)$  than near any other point of the unit circle. In this case, the main result of [5]

is that an eigenvector of  $-h^2\Delta + V$  with minimal eigenvalue is, for  $h$  small, located near  $(-1, 0)$ .

This result validates, in the setting of Schrödinger operators, the physical effect of *semiclassical order from disorder* [4]: not all points in classical phase space where the energy is minimal are equivalent for quantum systems. However, one of the main physical application of semiclassical order from disorder lies in the setting of frustrated spin systems, where the classical symplectic manifold is a product of spheres. The mathematical setting here strongly differs from Schrödinger operators.

We propose to study Toeplitz operators, of which spin systems are a particular case. As for pseudo-differential operators, to a real function (or symbol)  $h$  on a symplectic manifold we associate an auto-adjoint operator  $T_N(h)$  on a Hilbert space, depending on a small parameter which is the inverse of an integer  $N$ . For this we need an additional geometric structure on the manifold. For pseudo-differential operators the symplectic manifold is supposed to be of the form  $T^*X$  and the Hilbert space is  $L^2(X)$ . For Toeplitz operators we suppose that the manifold has a Kähler structure, and the Hilbert space is a set of holomorphic sections in a convenient bundle.

## 1.2 Main results

In a previous paper [3], we developed a set of techniques in order to study the first eigenfunctions of a Toeplitz operator, under the hypothesis that the minimal set of the symbol is a finite set of non-degenerate critical points.

We prove two main results with relaxed conditions. Theorem A only supposes a smooth symbol and is independent of the properties of the minimal set. Theorem B is more precise and applies in a particular setting which corresponds to [5].

**Theorem A.** *Let  $M$  be a smooth compact Kähler quantizable manifold and  $h \in C^\infty(M, \mathbb{R})$ . Suppose that  $\min(h) = 0$ .*

*To each point  $x \in M$  such that  $h(x) = 0$ , let  $q$  be the Hessian quadratic form of  $h$  at  $x$ , read in some complex coordinates, and let  $\mu(x)$  be the infimum of the spectrum of  $T_N(q)$  (which does not depend on the choice of coordinates).*

*Then, for any sequence  $(u_N)_{N \in \mathbb{N}}$  of unit eigenfunctions corresponding to the first eigenvalue of  $T_N(h)$ , for any open set  $U$  at positive distance from*

$$\{x \in M, h(x) = 0, \mu(x) \text{ is minimal}\},$$

*there holds*

$$\int_U |u_N|^2 = O(N^{-\infty}).$$

**Theorem B.** *Suppose that the function  $\mu$  above reaches its non-degenerate minimum on a unique point  $x_0$ , in a neighbourhood of which  $\{h = 0\}$  is a smooth isotropic submanifold.*

*Then for any sequence  $(u_N)_{N \in \mathbb{N}}$  of unit eigenfunctions corresponding to the first eigenvalue of  $T_N(h)$ , for any  $\epsilon > 0$ , one has*

$$\int_{\{\text{dist}(y, x_0) > N^{-\frac{1}{4} + \epsilon}\}} |u_N(y)|^2 = O(N^{-\infty}).$$

*Moreover, the first eigenvalue is simple and the spectral gap is of order  $N^{-\frac{3}{2}}$ .*

### 1.3 Outline

In Section 2 we recall the necessary material on Toeplitz operators, including a universality lemma proved in [3], and quantum maps as developed in [2].

Section 3 contains the main tool in the proof, which is a Toeplitz version of the well-known Melin estimates [8, 6]. We give a global and a local version of these estimates, and use them to prove pseudolocality of the resolvent at a distance  $\geq \epsilon N^{-1}$  of the spectrum, for every  $\epsilon > 0$ .

Section 4 concludes the proof of Theorem A, based on the Melin estimate.

In Section 5 we prove Theorem B through a normal form corresponding to its particular setting.

Section 6 contains various examples of mathematical and physical settings which motivate Theorems A and B.

## 2 Toeplitz quantization

### 2.1 The Szegő projector

Let  $M$  be a Kähler manifold of dimension  $n$ , with symplectic form  $\omega$ . If the Chern class of  $\omega/2\pi$  is integral, there exists a Hermitian holomorphic line bundle  $(L, h)$  over  $M$ , with curvature  $-i\omega$  ([10], pp. 158-162).

Let  $(L^*, h^*)$  be the dual line bundle of  $L$ , with dual metric. Let  $D$  be the unit ball of  $L^*$ , that is:

$$\{D = (m, v) \in L^*, \|v\|_{h^*} < 1\}.$$

The boundary of  $D$  is denoted by  $X$ . It admits an  $S^1$  action

$$\begin{aligned} r_\theta : X &\mapsto X \\ (m, v) &\mapsto (m, e^{i\theta} v). \end{aligned}$$

We are interested in the equivariant Hardy spaces on  $X$ , defined as follows:

**Definition 2.1.**

- The *Hardy space*  $H(X)$  is the closure in  $L^2(X)$  of

$$\{f|_X, f \in C^\infty(D \cup X), f \text{ holomorphic in } D\}.$$

- The Szegő projector  $S$  is the orthogonal projection from  $L^2(X)$  onto  $H(X)$ .
- Let  $N \in \mathbb{N}$ . The *equivariant Hardy space*  $H_N(X)$  is defined by:

$$H_N(X) = \{f \in H(X), \forall(x, \theta) \in X \times \mathbb{S}^1, f(r_\theta x) = e^{iN\theta} f(x)\}.$$

- Let  $N \in \mathbb{N}$ . The equivariant Szegő projector  $S_N$  is the orthogonal projection from  $L^2(X)$  onto  $H_N(X)$ .

Throughout this paper, we will work with the sequence of spaces  $H_N(X)$ . If  $M$  is compact, then the spaces  $H_N(X)$  are finite-dimensional spaces of smooth functions. Hence the Szegő projector has a Schwartz kernel, that we will also denote by  $S_N$ .

Another important example is the case  $M = \mathbb{C}^n$ , with standard Kähler form, where the equivariant Hardy spaces are explicit:

**Proposition 2.2.** *If  $M = \mathbb{C}^n$  with standard Kähler form, then*

$$H_N(X) \simeq \mathcal{B}_N := L^2(\mathbb{C}^n) \cap \{z \mapsto e^{-\frac{N}{2}|z|^2} f(z), f \text{ is an entire function}\}.$$

*The space  $\mathcal{B}_N$  is a closed subspace of  $L^2(\mathbb{C}^n)$ . The orthogonal projector  $\Pi_N$  from  $L^2(\mathbb{C}^n)$  to  $\mathcal{B}_N$  admits as Schwartz kernel the function*

$$\Pi_N : z, w \mapsto \left(\frac{N}{\pi}\right)^n \exp\left(-\frac{1}{2}N|z - w|^2 + iN\Im(z \cdot \bar{w})\right).$$

Observe that the sequence of kernels  $\Pi_N$  is rapidly decreasing outside the diagonal set. A very important fact is that this property holds also in the case of a compact Kähler manifold:

**Proposition 2.3** ([7], prop 4.1, or [1, 9]). *Let  $M$  be a compact Kähler manifold, and  $(S_N)_{N \geq 1}$  be the sequence of Szegő projectors of Definition 2.1. Let  $\delta \in [0, 1/2)$ . For every  $k \geq 0$  there exists  $C$  such that, for every  $N \in \mathbb{N}$ , for every  $x, y \in X$  such that  $\text{dist}(\pi(x), \pi(y)) \geq N^{-\delta}$ , one has*

$$|S_N(x, y)| \leq CN^{-k}.$$

This roughly means that, though the operators  $S_N$  are non-local, their “interaction range” decreases with  $N$ .

In the spirit of the previous proposition, we define what it means for a sequence of functions in  $H_N(X)$  to be localized.

**Definition 2.4.** Let  $u = (u_N)_{N \in \mathbb{N}}$  be a sequence of unit elements of  $L^2(X)$ . Let  $dVol$  denote the Liouville volume form on  $M$ . For every  $N$ , the probability measure  $|u_N|^2 dVol \otimes d\theta$  is well-defined on  $X$ , and we call  $\mu_N$  the pull-back of this measure on  $M$ .

Let moreover  $Z \subset M$  compact. We say that the sequence  $u$  microlocalizes on  $Z$  when, for every open set  $U \subset M$  at positive distance from  $Z$ , one has, as  $N \rightarrow +\infty$ :

$$\mu_N(U) = O(N^{-\infty}).$$

A corollary of this definition is that, if a sequence  $(u_N)_{N \in \mathbb{N}}$  microlocalizes on a set  $Z$ , then so does the sequence  $(S_N u_N)_{N \in \mathbb{N}}$ .

To complete Proposition 2.3, we have to describe how  $S_N$  acts on sequences of functions concentrated on a point. For this we need a convenient choice of coordinates.

Let  $P_0 \in M$ . The real tangent space  $T_{P_0}M$  carries a Euclidian structure and an almost complex structure coming from the Kähler structure on  $M$ . We then can (non-uniquely) identify  $\mathbb{C}^n$  with  $T_{P_0}M$ .

**Definition 2.5.** Let  $U$  be a neighbourhood of 0 in  $\mathbb{C}^n$  and  $V$  be a neighbourhood of a point  $P_0$  in  $M$ .

A smooth diffeomorphism  $\rho : U \times \mathbb{S}^1 \rightarrow \pi^{-1}(V)$  is said to be a *normal map* or map of *normal coordinates* under the following conditions:

- $\forall (z, v) \in U \times \mathbb{S}^1, \forall \theta \in \mathbb{R}, \rho(z, ve^{i\theta}) = r_\theta \rho(z, v)$ ;
- Identifying  $\mathbb{C}^n$  with  $T_{P_0}M$  as previously, one has:

$$\forall (z, v) \in U \times \mathbb{S}^1, \pi(\rho(z, v)) = \exp(z).$$

**Remark 2.6.** The choice a normal map around a point  $P_0$  reflects the choice of an identification of  $\mathbb{C}^n$  with  $T_{P_0}(M)$  and a point over  $P_0$  in  $X$ . Hence, if  $\rho_1$  and  $\rho_2$  are two normal maps around the same point  $P_0$ , then  $\rho_1^{-1} \circ \rho_2 \in U(n) \times U(1)$ .

We can pull-back by a normal map the projector  $\Pi_N$  on the Bargmann spaces by the following formula:

$$\rho^* \Pi_N(\rho(z, \theta), \rho(w, \phi)) := e^{iN(\theta - \phi)} \Pi_N(z, w).$$

By convention,  $\rho^* \Pi_N$  is zero outside  $\pi^{-1}(V)^2$ .

**Proposition 2.7.** *Let  $P_0 \in M$ , and  $\rho$  a normal map around  $P_0$ . For every  $\epsilon > 0$  there exists  $\delta \in (0, 1/2)$  and  $C > 0$  such that for every  $N \in \mathbb{N}$ , for every  $u \in L^2(X)$ , if the support of  $u$  lies inside  $\rho(B(0, N^{-\delta}) \times \mathbb{S}^1)$ , then*

$$\|(S_N - \rho^* \Pi_N)u\|_{L^2} < CN^{-\frac{1}{2} + \epsilon}.$$

In a sense, Proposition 2.7 states that the kernel  $S_N$  asymptotically looks like  $\Pi_N$ . This proposition was proven in [3], as a consequence of previously known results on the asymptotical behaviour of the Schwartz kernel of  $S_N$  near the diagonal set [9, 7, 1].

## 2.2 Toeplitz operators

**Definition 2.8.** Let  $M$  be a Kähler manifold, with equivariant Szegő projectors  $S_N$ .

Let  $f \in C^\infty(M)$  be a smooth function on  $M$ .

The Toeplitz operator  $T_N(f) : H_N(X) \rightarrow H_N(X)$  associated with the symbol  $f$  is defined as

$$T_N(f) = S_N f S_N.$$

### 2.2.1 Toeplitz operators on $\mathbb{C}^n$

The manifold  $\mathbb{C}^n$  is not compact. Let us release the condition that the symbol is bounded. This defines Toeplitz operators as unbounded operators on  $\mathcal{B}_N$ .

If  $q$  is a quadratic form on  $\mathbb{R}^{2n}$  identified with  $\mathbb{C}^n$ , then  $T_N^{flat}(q)$  is essentially self-adjoint. This operator is related to the Weyl quantization  $Op_W^h(q)$  with semi-classical parameter  $h = N^{-1}$ . In fact,  $T_{h^{-1}}^{flat}(q)$  is conjugated, via a Bargmann transform  $B_N$ , to  $Op_W^h(q) + \frac{h}{2} \text{tr}(q)$ .

**Definition 2.9.** Let  $q$  be a non-negative quadratic form on  $\mathbb{R}^{2n}$ , identified with  $\mathbb{C}^n$ .

We define  $\mu(q) := \inf \left( \text{Sp}(T_1^{flat}(q)) \right)$ .

**Remark 2.10.** The function  $\mu$  is invariant under the  $U(n)$  symmetry, and continuous on the set of semi-definite quadratic forms [8]. It can be computed via a symplectic diagonalization of  $q$  (cf Proposition 5.1).

### 2.2.2 Toeplitz operators on compact manifolds

When the base manifold  $M$  is compact and  $f$  is real-valued, for fixed  $N$  the operator  $T_N(f)$  is a symmetric operator on a finite-dimensional space.



In this setting, we will speak freely about eigenvalues and eigenvectors of Toeplitz operators.

It turns out that Definition 2.8 is not robust enough for the set of all Toeplitz operators to be an algebra. One finds instead that the composition of two Toeplitz operators can be written, in the general case, as a formal series of Toeplitz operators [1], that is:

$$T_N(f)T_N(g) = T_N(fg) + N^{-1}T_N(C_1(f, g)) + N^{-2}T_N(C_2(f, g)) + \dots$$

This calls for a construction of Toeplitz operators associated with formal series, which are defined modulo the  $O(N^{-\infty})$  sequences of operators. In this paper we only need to use Definition 2.8. However, the properties of the  $C^*$ -algebra of formal series of Toeplitz operators lead to the following property, which appears in previous work [3], and which is an important first step towards the study of the low-energy spectrum.

**Proposition 2.11.** *Let  $M$  be a compact Kähler manifold and  $h$  a real nonnegative smooth function on  $M$ .*

*Let  $u = (u_N)_{N \in \mathbb{N}}$  be a sequence of unit elements of  $L^2(X)$  such that, for every  $N$ , one has*

$$T_N(h)u_N = \lambda_N u_N,$$

*with  $\lambda_N = O(N^{-1})$ .*

*Then the sequence  $u$  microlocalizes on  $\{h = 0\}$ . More precisely, for every  $\epsilon > 0$ , if*

$$Z_N = \{m \in M, h(m) \geq N^{-1+\epsilon}\},$$

*one has, as  $N \rightarrow +\infty$ ,*

$$\langle u_N, \mathbb{1}_{Z_N} u_N \rangle = O(N^{-\infty}).$$

On a minimal point of  $h$ , one can pull-back Definition 2.9 by normal coordinates of Definition 2.5:

**Definition 2.12.** Let  $h \in C^\infty(M, \mathbb{R}^+)$ . Let  $x \in M$  such that  $h(x) = 0$ . Let  $\rho$  be a normal map around  $x$ ; the function  $h \circ \rho$  is well-defined and non-negative on a neighbourhood of 0 in  $\mathbb{C}^n$ , and the image of 0 is 0. Hence the 2-jet of  $h \circ \rho$  is a quadratic form  $q$ .

We define  $\mu(x)$  as  $\mu(q)$ .

**Remark 2.13.** A different choice of normal coordinates corresponds to a  $U(n)$  change of variables for  $q$ , under which  $\mu$  is invariant. Hence  $\mu(x)$  does not depend on the choice of normal coordinates.

The function  $x \mapsto \mu(x)$  is continuous as it is a composition of two continuous functions.

### 2.3 Quantum maps

Symplectomorphisms can be lifted at the quantum level [2]:

**Proposition 2.14.** *Let  $\sigma : (M, x) \mapsto (N, y)$  a local symplectomorphism between two quantizable Kähler manifolds.*

*Let  $U$  a small open set around  $x$ . Then there exists, for every  $N$ , a linear map  $\mathfrak{S}_N : H_N(M, L) \mapsto H_N(N, K)$  such that, for any sequence  $(u_N)_{N \in \mathbb{N}}$  of sections microsupporting inside  $U$ , and for any symbol  $a \in C^\infty(N)$ , there exists a sequence  $b$  of symbols such that:*

$$\begin{aligned} \|\mathfrak{S}_N u_N\|_{L^2} &= \|u_N\|_{L^2} + O(N^{-\infty}) \\ \mathfrak{S}_N^{-1} T_N(a) \mathfrak{S}_N u_N &\sim T_N(a \circ \phi + \sum_{k=1}^{\infty} N^{-k} b_k) u_N. \end{aligned}$$

## 3 Resolvent estimates

### 3.1 A cutting lemma

**Lemma 3.1.** *Let  $Y$  be a compact Riemannian manifold. There exists a constant  $C > 0$  such that, for every positive integrable function  $f$  on  $Y$ , for every  $a > 0$  and  $t \in (0, 1)$ , there exists a finite family  $(U_j)_{j \in J}$  of open subsets of  $Y$  with the following properties:*

$$\begin{aligned} \forall j \in J, \text{diam}(U_j) &< a. \\ \forall j \in J, \text{dist} \left( Y \setminus U_j, Y \setminus \bigcup_{i \neq j} U_i \right) &\geq ta. \\ \sum_{i \neq j} \int_{U_i \cap U_j} f &\leq Ct \int_Y f. \end{aligned}$$

**Proof.** Let  $m \in \mathbb{N}$  be such that there exists a smooth embedding of differential manifolds from  $Y$  to  $\mathbb{R}^m$ , and let  $\Phi$  be such an embedding.  $\Phi$  may not preserve the Riemannian structure, so let  $c_1$  be such that, for any  $\xi \in TY$ , one has

$$c_1 \|\Phi^* \xi\| \leq \|\xi\|.$$

We now let  $L > 0$  such that any hypercube  $H$  in  $\mathbb{R}^m$  of side  $2/L$  is such that  $\text{diam}(\Phi^{-1}(H)) < a$ .

At this point we make the further claim that  $C = \frac{2maL}{c_1}$ .

Let  $1 \leq k \leq m$ , and let  $\Phi_k$  denote the  $k$ -th component of  $\Phi$ . The function  $\Phi_k$  is continuous from  $Y$  to a segment of  $\mathbb{R}$ . Without loss of

generality this segment is  $[0, 1]$ . Let  $g_k$  denote the integral of  $f$  along the level sets of  $\Phi_k$ . The function  $g_k$  is a positive integrable function on  $[0, 1]$ . Let  $t' > 0$  be the inverse of an integer, and  $0 \leq \ell \leq L - 1$ . In the interval  $[\ell/L, (\ell + 1)/L]$ , there exists a subinterval  $I$ , of length  $t'/L$ , such that

$$\int_I g_k \leq t' \int_{\ell/L}^{(\ell+1)/L} g_k. \quad (1)$$

Indeed, one can cut the interval  $[\ell/L, (\ell + 1)/L]$  into  $1/t'$  intervals of size  $t'/L$ . If none of these intervals was verifying (1), then the total integral would be strictly greater than itself.

Let  $x_{k,\ell}$  denote the centre of such an interval. Then, let

$$\begin{aligned} V_{k,0} &= \left[0, x_{k,0} + \frac{t'}{2L}\right) \\ V_{k,\ell} &= \left(x_{k,\ell-1} - \frac{t'}{2L}, x_{k,\ell} + \frac{t'}{2L}\right) \text{ for } 1 \leq \ell \leq L \\ V_{k,L+1} &= \left(x_{k,L} - \frac{t'}{2L}, 1\right]. \end{aligned}$$

Each open set  $V_{k,l}$  has a length smaller than  $2/L$ . The overlap of two consecutive sets has a length  $t'$ , and the sum of the integrals on the overlaps is less than  $t' \int_0^1 g_k = t' \int_Y f$ .

Now let  $\nu$  denote a polyindex  $(\nu_k)_{1 \leq k \leq m}$ , with  $\nu_k \leq L + 1$  for every  $k$ . Define

$$U_\nu = \Phi^{-1}(V_{1,\nu_1} \times V_{2,\nu_2} \times \dots \times V_{m,\nu_m}).$$

Then  $\text{diam } U_\nu \leq a$  because it is the pull-back of an open set contained in a hypercube of side  $2/L$ . Moreover, one has

$$\text{dist} \left( Y \setminus U_\nu, Y \setminus \bigcup_{\nu' \neq \nu} U_{\nu'} \right) \geq \frac{c_1 t'}{L}.$$

To conclude, observe that

$$\sum_{\nu \neq \nu'} \int_{U_\nu \cap U_{\nu'}} f = \sum_{k=1}^m \sum_{\ell=0}^L \int_{V_{k,\ell} \cap V_{k,\ell+1}} g_k \leq m t' \int_Y f.$$

It only remains to choose  $t'$  conveniently. The fraction  $t \frac{aL}{c_1}$  may not be the inverse of an integer; however the inverse of some integer lies in  $[\frac{aL}{2c_1}, \frac{aL}{c_1}]$ . This allow us to conclude.  $\square$

**Remark 3.2.** In the previous Lemma, the number of elements of  $J$  is bounded by a polynomial in  $a$  that depends only on the geometry of  $Y$ .

### 3.2 Melin estimate

**Proposition 3.3** (Melin estimate). *Let  $h \in C^\infty(M, \mathbb{R}^+)$  with  $\{h = 0\} \neq \emptyset$ . Let*

$$\lambda_{\min} = \min_{h(x)=0} (\mu(x)).$$

*Then there exists  $\varepsilon > 0$  independent of  $h$ , and there exists  $N_0$  and  $C > 0$  such that, for every  $N \geq N_0$ , one has*

$$\min \operatorname{Sp}(T_N(h)) \geq \lambda_{\min} N^{-1} - CN^{-1-\varepsilon}.$$

*Proof.* Recall from the universality principle that, for  $\delta$  small enough, for every  $x \in M$  with associated normal map  $\rho$ , for every  $u$  with support inside  $\rho(B(0, N^{-\frac{1}{2}+\delta}) \times \mathbb{S}^1)$ , one has

$$\|(S_N - \rho^* \Pi_N)u\|_{L^2} < CN^{-\frac{1}{4}}.$$

Hence, for  $N$  large enough, for every  $u$  whose support has a diameter of order  $N^{-\frac{1}{2}+\delta_0}$ , one has

$$\langle S_N u, h S_N u \rangle \geq (\lambda_{\min} N^{-1} - CN^{-1-\varepsilon}) \|u\|^2.$$

From this local estimate, we deduce a global estimate using the universality lemma proved previously, and general localisation estimates proved in [3].

Indeed, let  $u_N$  be a sequence of normalised eigenvectors for  $T_N(h)$  with minimal eigenvalue. Either the associated sequence of eigenvalues is not  $O(N^{-1})$ , in which case there is nothing to prove, or it is, in which case  $u_N$  is  $O(N^{-\infty})$  outside  $\{h \leq N^{-1+\delta_1}\}$  for every  $\delta_1 > 0$ .

We now invoke Lemma 3.1 with the following data:

- $Y = M$ .
- $f = |u_N|^2$ .
- $a = N^{-\frac{1}{2}+\delta_0}$ .
- $t = N^{-\frac{\delta_0}{2}}$ .

The lemma yields a sequence of coverings  $(U_{j,N})_{j \in J_N, N \in \mathbb{N}}$ . The proof also yields a sequence of coverings by slightly smaller open sets  $(U'_{j,N})$ , with

- $U'_{j,N} \subset U_{j,N}$ .
- $d(M \setminus U_{j,N}, U'_{j,N}) \geq \frac{1}{2} N^{-\frac{1-\delta_0}{2}}$ .

The second condition of Lemma 3.1 ensures that one can find a partition of unity  $(\chi_{j,N})_{j \in J_N, N \in \mathbb{N}}$  associated with the covering  $(U'_{j,N})$ .

Then, for every  $N$ , for every  $j \neq k \in J_N$ , the integral

$$\langle S_N \chi_{j,N} u_N, h S_N \chi_{k,N} u_N \rangle$$

is  $O(N^{-\infty})$  outside  $(U_{i,N} \cap U_{j,N})^3$ , moreover  $S_N \chi_{k,N} u_N$  is  $O(N^{-\infty})$  outside  $\{h \geq N^{-1+\delta_1}\}$  for all  $\delta_1 > 0$ , hence

$$|\langle S_N \chi_{j,N} u_N, h S_N \chi_{k,N} u_N \rangle| \leq CN^{-1+\delta_1} \| |u_N|^2 \|_{L^1(U_i \cap U_j)} + O(N^{-\infty}).$$

Hence, by Lemma 3.1, for every  $N$ , one has

$$\sum_{j \neq k \in J_N} |\langle \chi_{j,N} u_N, T_N(h) \chi_{k,N} u_N \rangle| \leq CN^{-1+\delta_1} N^{-\frac{\delta_0}{2}} \|u_N\|_{L^2}^2 + O(N^{-\infty}).$$

(Recall  $|J_N|$  has polynomial growth in  $N$ .)

On the other hand, there holds

$$\sum_{j \in J_N} \langle \chi_{j,N} u_N, T_N(h) \chi_{j,N} u_N \rangle \geq (\lambda_{\min} N^{-1} - CN^{-1-\epsilon}) \sum_{j \in J_N} \|S_N \chi_{j,N} u_N\|_{L^2}^2.$$

Since  $S_N \chi_{j,N} u_N$  and  $S_N \chi_{k,N}$  are almost orthogonal for  $j \neq k$ , one has

$$\sum_{j \in J_N} \|S_N \chi_{j,N} u_N\|_{L^2}^2 \geq (1 - CN^{-\epsilon}) \|u_N\|_{L^2}^2.$$

Then, choosing  $\delta_1 < \frac{\delta_0}{2}$  allow us to conclude:

$$\langle u_N, T_N(h) u_N \rangle \geq N^{-1} (\lambda_{\min} - CN^{-\epsilon}) \|u_N\|_{L^2}^2.$$

□

Note that, in the last proof, it is essential that we know beforehand that  $u_N$  is  $O(N^{-\infty})$  on  $\{h \geq N^{-1+\delta}\}$  for every  $\delta > 0$ . This was achieved by picking  $u_N$  as the unique minimizer of  $\langle u, T_N(h) u \rangle$  under  $\|u\| = 1$ , in which case  $u_N$  is an eigenfunction of  $T_N(h)$ .

### 3.3 Pseudo-locality of the resolvent

**Proposition 3.4.** *Let  $h$  and  $\lambda_{\min}$  as in proposition 3.3. Then, for every  $\epsilon$ , the operator  $T_N(h - N^{-1}(\lambda_{\min} - \epsilon))$  is invertible (as a positive definite operator on a finite-dimensional space). Its inverse  $R_\epsilon$  is pseudo-local: if  $a$  and  $b$  are smooth functions with  $\text{supp}(a) \cap \text{supp}(b) = \emptyset$ , then*

$$T_N(a) R_\epsilon T_N(b) = O(N^{-\infty}).$$

*Proof.* The proposition may be reformulated this way: if  $U \subset\subset V$  are two open sets in  $M$  and a sequence  $(u_N)_{N \in \mathbb{N}}$  of normalised states is such that  $T_N(h - N^{-1}(\lambda_{min} - \epsilon))u_N = O_{L^2}(N^{-\infty})$  on  $V$ , then we wish to prove that  $u_N = O_{L^2}(N^{-\infty})$  on  $U$ .

We first remark that, for every  $\delta$ , and for every  $U \subset\subset V_1 \subset\subset V$ , there holds

$$\int_V \bar{u} T_N(h) u \geq CN^{-1+\delta} \int_{V_1 \cap \{h \geq N^{-1-\delta}\}} |u|^2.$$

Hence,  $u$  is  $O(N^{-\infty})$  on  $V_1 \cap \{h \geq N^{-1-\delta}\}$  for every  $\delta$ .

We are now able to repeat the proof of Proposition 3.3 by cutting a neighbourhood of  $U$  into small pieces, hence the claim.  $\square$

## 4 Proof of Theorem A

### 4.1 Estimate of the first eigenvalue

**Proposition 4.1.** *Let  $\lambda_{min}$  be as in Proposition 3.3. Then there exists  $\epsilon_0 > 0$  such that*

$$\inf Sp(T_N(h)) \leq N^{-1}\lambda_{min} + N^{-1-\epsilon_0}.$$

*Proof.* Let  $x \in M$  achieving the minimal value  $\lambda_{min}$ ,  $\rho$  a normal map around  $x$ , and  $\delta$  such that, for every  $N$ , for every  $u$  supported on  $B(x, N^{-\frac{1}{2}+\delta})$ , one has  $\|(S_N - \rho^* \Pi_N)u\| = O(N^{-\frac{1}{4}})$ , and suppose  $\delta_0 < \frac{1}{8}$ .

Pick  $\alpha \geq 2\delta$ , and let  $q$  be the Hessian of  $h_0$  at  $x$ . Then, since the function  $q \mapsto \mu(q)$  is Hölder continuous with exponent  $\frac{1}{2n}$  [8], one has

$$\mu(q + N^\alpha |\cdot|^2) \leq \mu(q) + CN^{-\frac{\alpha}{2n}}.$$

Let  $v_N$  denote a normalized ground state of  $T_N^{flat}(q + N^\alpha |\cdot|^2)$ , then  $v_N$  is  $O(N^{-\infty})$  outside  $B(0, N^{-\frac{1}{2}+\delta})$ . Then  $\langle \rho^* v_N, T_N(h) v_N \rangle = \mu(q + N^\alpha |\cdot|^2) + N^{-1}h_1(x) + O(N^{-\frac{5}{4}+2\delta}) \leq \lambda_{min} + O(N^{-1-\epsilon})$  for some  $\epsilon > 0$ .  $\square$

### 4.2 End of the proof

We can now conclude the proof of Theorem A. Let  $a \in C^\infty(M)$  supported away from the set of points achieving  $\lambda_{min}$ . Let  $\tilde{h} \in C^\infty(M)$  be such that  $\tilde{h} = h$  on the support of  $a$ , and such that the  $\lambda_{min}(\tilde{h}) > \lambda_{min}(h)$ . Then  $T_N(\tilde{h} - N^{-1}\lambda_{min}(h))$  is invertible because of the Melin estimate of Proposition 3.3. Its inverse  $R$  is pseudolocal, and its norm is  $O(N)$ ; in particular,

for every integer  $k$ , there holds  $T_N(a) = T_N(h - N^{-1}\lambda_{\min}(h))^k R^k T_N(a) + O(N^{-\infty})$ . If  $u_N$  is a sequence of unit ground states of  $T_N(h)$ , one has

$$\langle u_N, T_N(a)u \rangle \leq C^k N^{-k-k\epsilon} \langle u, R^k T_N(a)u_N \rangle$$

because of Proposition 4.1. In particular, for every  $k$ , one has

$$\langle u_N, T_N(a)u_N \rangle = O(N^{-k\epsilon}),$$

which concludes the proof of Theorem A.

## 5 Reduction of the regular case

### 5.1 A convenient chart

We begin with the following fact:

**Proposition 5.1.** *Let us endow  $\mathbb{R}^{2n}$  with the canonical symplectic structure given by  $J = \begin{pmatrix} 0 & -I \\ I & 0 \end{pmatrix}$ , and let  $(q_1, \dots, q_n, p_1, \dots, p_n)$  denote the canonical basis.*

*Let  $Q : \mathbb{R}^d \mapsto S_{2n}^+(\mathbb{R})$  a smooth  $d$ -parameter family of semi-positive quadratic forms. Suppose rank  $Q = r$  is a constant function and  $\ker Q$  is a smooth map into the set of isotropic subspaces of  $(\mathbb{R}^{2n}, J)$ .*

*Then there is a smooth family  $S : \mathbb{R}^d \mapsto Sp(2n)$  of symplectic matrices, and smooth functions  $\lambda_i : \mathbb{R}^d \mapsto \mathbb{R}_+^*$ ,  $1 \leq i \leq n - r$ , such that*

$$S^T Q S = \sum_{i=1}^{n-r} \lambda_i (p_i^2 + q_i^2) + \sum_{i=n-r+1}^n p_i^2.$$

*In particular, the function  $\mu(Q)$  is smooth.*

In the study of the hamiltonian dynamics related to  $Q$ , the variables  $p_i, n - r + 1 \leq i \leq n$  are called *slow modes*. They correspond to a constant drift. The variables  $p_i, q_i, 1 \leq i \leq n - r$  are called *fast modes* and correspond to harmonic oscillations.

Here, the *zero modes* (that is, the kernel of  $Q$ ) are supposed to form an isotropic subspace; this can be generalized, but  $\ker Q$  must have a constant symplectic rank in order for such a result to apply.

*Proof.* Let us construct by induction on  $n$  a symplectic basis of  $\mathbb{R}^n$ , denoted by  $(x_1, \dots, x_n, y_1, \dots, y_n)$ , depending smoothly on the parameters, on which

the quadratic form  $q$  related to  $Q$  is diagonal, with the desired diagonal terms.

Suppose  $r > 0$ . Pick  $x_n \in \ker Q$  in a continuous manner. The quadratic form  $q$  is degenerate so it may have isotropic subspaces, but it is a well-known fact that it has no co-isotropic subspaces: if a subspace  $F$  is such that  $\{y \in \mathbb{R}^{2n}, \langle x, Qy \rangle = 0 \forall x \in F\} \subset F$ , then  $F = \mathbb{R}^{2n}$ .

Hence, with  $F = \{z \in \mathbb{R}^{2n}, \langle z, Jx_n \rangle = 0\}$  the symplectic orthogonal of  $x_n$ , there exists  $y_n$  such that:

$$\begin{aligned} \langle y_n, Jx_n \rangle &= 1 \\ \forall z \in F, \langle z, Qy_n \rangle &= 0. \end{aligned}$$

The vector  $y_n$  again depends smoothly on the parameters. As  $\lambda = \langle y_n, Qy_n \rangle$  is far from zero on compact sets (recall  $\ker Q$  is a continuous family of isotropic subspaces), changing  $x_n$  into  $\sqrt{\lambda}x_n$  and  $y_n$  into  $y_n/\sqrt{\lambda}$  yields two smooth vectors with the supplementary condition that  $\langle y_n, Qy_n \rangle = 1$ .

By induction, if one can find a smooth symplectic basis  $(x_1, \dots, x_{n-1}, y_1, \dots, y_{n-1})$  of the symplectic orthogonal of  $(x_n, y_n)$ , which diagonalizes the restriction of  $Q$  with diagonal values as above, then completing this basis with  $x_n$  and  $y_n$  achieves the goal of the proposition.

If  $r = 0$ , then  $Q^{\frac{1}{2}}$  is a smooth family of symmetric matrices, so that  $Q^{\frac{1}{2}}JQ^{\frac{1}{2}}$  is a smooth family of antisymmetric matrices. Hence, there is a smooth family  $U$  of orthogonal matrices, and a smooth family  $D$  of positive diagonal matrices, such that

$$U^T Q^{\frac{1}{2}} J Q^{\frac{1}{2}} U = \begin{pmatrix} 0 & D \\ -D & 0 \end{pmatrix}.$$

In particular, with  $A = \begin{pmatrix} D^{\frac{1}{2}} & 0 \\ 0 & D^{\frac{1}{2}} \end{pmatrix}$ , one has

$$(AU^T Q^{\frac{1}{2}} J) Q (-J Q^{\frac{1}{2}} U A) = \begin{pmatrix} D & 0 \\ 0 & D \end{pmatrix},$$

and

$$(AU^T Q^{\frac{1}{2}} J) J (-J Q^{\frac{1}{2}} U A) = J.$$

Hence the desired symplectic matrix is  $AU^T Q^{\frac{1}{2}} J$ , which depends smoothly on the parameters.  $\square$

Recall the following well-known application of Moser's principle:



**Proposition 5.2.** *Let  $S$  a symplectic manifold and  $Z \subset S$  a smooth  $d$ -dimensional submanifold of constant symplectic rank. Then, in a neighbourhood of any point in  $Z$ , there is a symplectomorphism  $\rho$  onto a neighbourhood of zero of  $\mathbb{R}^{2n}$ , such that  $\mathbb{R}^d \times \{0\} = \rho(Z)$ .*

Using the two previous Propositions, we will prove the normal form for miniwells on isotropic submanifolds:

**Proposition 5.3.** *Let  $h$  be a smooth function on  $M$ , which vanishes at order 2 on an isotropic manifold  $Z$  of dimension  $r$ .*

*Near any point of  $Z$ , there is a symplectomorphism onto  $\mathbb{R}_{q,p}^{2r} \times \mathbb{R}_{x,\xi}^{2(n-r)}$ , a smooth function  $Q_S$  from  $\mathbb{R}^r$  into the set of positive quadratic forms of dimension  $r$ , and  $n - r$  smooth positive functions  $(\lambda_i)_{1 \leq i \leq n-r}$  such that:*

$$h \circ \rho^{-1} = \sum_{i=1}^{n-r} \lambda_i(q)(x_i^2 + \xi_i^2) + Q_S(q)(p) + O_{(x,\xi,p) \rightarrow 0}(|x|^3 + |\xi|^3 + |p|^3).$$

In particular, in the previous proposition,  $Z$  is mapped into  $\{(p, x, \xi) = 0\}$ .

*Proof.* The Proposition 5.1 yields, at each point of  $Z$  in a neighbourhood of 0, a family of  $2n$  vector fields which form a symplectic basis:

$$(Q_1, \dots, Q_r, P_1, \dots, P_r, X_1, \dots, X_{n-r}, \Xi_1, \dots, \Xi_{n-r}),$$

such that  $\text{span}(Q_1, \dots, Q_r) = TZ$ . In the general setting, one cannot hope to diagonalize the quadratic form along the zero set (indeed,  $Q_1, \dots, Q_r$  are prescribed by the  $2n - r$  other vector fields, and do not commute in general). However, one can separate the slow variables and the fast variables.

Let  $m \in M$ , and let  $S$  be a piece of symplectic submanifold of  $M$ , tangent to  $(Q_1, \dots, Q_r, P_1, \dots, P_r)$  at  $Z$  near  $m$ . We first let  $\phi_0$  be a symplectomorphism from a neighbourhood of  $m$  in  $M$  into a neighbourhood of 0 in  $\mathbb{R}^{2r} \times \mathbb{R}^{2(n-r)}$ , such that  $S$  is mapped onto  $\mathbb{R}^{2r} \times 0$ . Then, let  $\phi_1$  a symplectomorphism on a neighbourhood of 0 in  $\mathbb{R}^{2r}$ , that maps  $\phi_0(Z)$  onto  $\mathbb{R}^r \times \{0\}$ . Then the map  $\tilde{\phi}_1$  acting on  $\mathbb{R}^{2r} \times \mathbb{R}^{2(n-r)}$  by

$$\tilde{\phi}_1(p, q, x, \xi) = (\phi_1(p, q), x, \xi)$$

is a symplectomorphism. We claim that  $\rho = \tilde{\phi}_1 \circ \phi_0$  is the desired change of variables.

Indeed, consider  $D\rho$  at a point of  $Z$ . Since  $\rho$  sends  $Z$  onto  $\mathbb{R}^r \times \{0\}$ , and  $S$  onto  $\mathbb{R}^{2r}$  times 0, the matrix of  $D\rho$ , from the basis  $\mathcal{B}$  to the canonical

basis, is of the form:

$$D\rho = \begin{pmatrix} A_{qq} & 0 & 0 & 0 \\ A_{pq} & A_{pp} & 0 & 0 \\ A_{xq} & A_{xp} & A_{xx} & A_{x\xi} \\ A_{\xi q} & A_{\xi p} & A_{\xi x} & A_{\xi\xi} \end{pmatrix}.$$

Moreover  $D\rho$  is symplectic, so that the bottom left part vanishes. Hence

$$h \circ \rho^{-1} = Q_F(q)(x, \xi) + Q_S(q)(p) + O(|p|^3 + |x|^3 + |\xi|^3),$$

for some quadratic forms  $Q_F$  and  $Q_S$ .

Since  $h$  vanishes at order 2 on  $Z$ , then  $Q_F$  is positive and  $Q_S$  only depends on  $p$  (and is positive).

It only remains to diagonalize  $Q_F$  with a symplectomorphism. In fact, this is possible without modifying  $Q_S$ . Indeed, let  $\phi : \mathbb{R}^r \mapsto Sp(2(n-r))$  be such that, for every  $q \in Z$ , the matrix  $\phi(q)$  realises a symplectic reduction of  $Q_F(q)$ , with eigenvalues  $\lambda_1(q), \dots, \lambda_{n-r}(q)$ . With  $J$  the standard complex structure matrix on  $\mathbb{R}^{2(n-r)}$  and  $\langle \cdot, \cdot \rangle$  its standard Euclidian norm, we define, for every  $1 \leq i \leq r$ , the real function

$$f_i : (q, x, \xi) \mapsto \frac{1}{2} \langle (x, \xi), (\partial_{q_i} \phi(q) J \phi^t(q))(x, \xi) \rangle.$$

We then define  $f : \mathbb{R}^{2n-r} \rightarrow \mathbb{R}^r$  as the map with components  $f_i$  in the canonical basis. Then a straightforward computation shows that the map

$$\Phi : (q, p, x, \xi) \mapsto (q, p + f, \phi(q)(x, \xi))$$

is a symplectomorphism. As  $f = O_{(x, \xi) \rightarrow 0}((x, \xi)^2)$ , the 2-jet of  $h \circ \Phi$  at  $(q, 0, 0, 0)$  is the same as the 2-jet of  $h \circ ((q, p, x, \xi) \mapsto (q, p, \phi(q)(x, \xi)))$ , i.e.  $Q_S(q)(p) + \sum_{i=1}^{n-r} \lambda_i(q)(x_1^2 + \xi_i^2)$ . This concludes the proof.  $\square$

## 5.2 Approximate eigenfunctions

Let us quantize the symplectic map of the previous Proposition, using Proposition 2.14, and conjugate with pseudodifferential operators:

**Definition 5.4.** For any choice  $\mathfrak{S}_N$  of quantization of the map  $\rho$  of Proposition 5.3, the classical symbol  $g_{\mathfrak{S}} \sim \sum N^{-i} g_i$  on a neighbourhood  $U$  of 0 in  $\mathbb{R}^{2n}$  is defined as follows: for any sequence  $u_N$  with microsupport in a compact set of  $U$ , there holds

$$B_N^{-1} \mathfrak{S}_N^{-1} T_N(h) \mathfrak{S}_N B_N u_N = Op_W^{N^{-1}}(g_{\mathfrak{S}}) u_N + O(N^{-\infty}).$$

In what follows, we choose any quantum map  $\mathfrak{S}_N$ , and we drop the subscript on  $g$ .

The reason we use Weyl quantization in this section is because we will heavily rely on squeezing operators. The computations are much easier to follow for this formalism.

Of course  $g_0 = h \circ \rho$ , and  $g_1$  is prescribed by the Melin estimates for both quantizations:

**Proposition 5.5.** *For any  $q$  close to 0, one has*

$$g_1(q, 0, 0, 0) = h_1 \circ \rho(q, 0, 0, 0) + \frac{1}{2} \sum_i \lambda_i(q) + \frac{1}{2} \text{tr}(Q_S(q)).$$

Let us find a candidate for the approximate eigenfunction:

**Proposition 5.6.** *Suppose that the function  $q \mapsto g_1(q, 0, 0, 0)$  has a non-degenerate minimum at  $q = 0$ . Let  $\phi$  the positive quadratic form such that  $q \mapsto e^{-\phi(q)}$  is the ground state of the quadratic operator*

$$Op_W^1(Q_S(0)(p) + \text{Hess } g_1(\cdot, 0, 0, 0)(q)),$$

with eigenvalue  $\mu_2$ .

Then there exists a sequence of polynomials  $(b_i)_{i \geq 1}$ , and a sequence of real numbers  $(\mu_i)_{i \geq 1}$ , with

$$\mu_0 = \sum_{i=1}^{n-r} \lambda_i(0) + \frac{1}{2} \text{tr}(Q_S(0)) = \mu(\text{Hess}(h_0)(\rho(0))) + h_1(\rho(0))$$

and  $\mu_1 = 0$  and  $\mu_2$  as previously, such that

$$N^{n-\frac{r}{2}} e^{-N\frac{x^2}{2} - \sqrt{N}\phi(q)} \left(1 + \sum_{i=1}^{+\infty} N^{-\frac{i}{4}} b_i(N^{\frac{1}{4}}q, N^{\frac{1}{2}}x)\right)$$

is an approximate eigenvector to  $Op_W^{N^{-1}}(g)$ , with eigenvalue

$$N^{-1} \sum_{i=0}^{+\infty} N^{-\frac{i}{2}} \mu_i,$$

in the sense that, for every  $K > 0$  there exists  $k > 0$  such that, if we truncate the expansion for the approximate eigenvalue and approximate eigenvector at order  $N^{-k}$ , one has

$$Op_W^{N^{-1}}(g)f_N^k = \lambda_N^k f_N^k + O(N^{-K}).$$

*Proof.* The proof proceeds by a squeezing of  $Op_W^{N^{-1}}(g)$  by a factor  $N^{\frac{1}{4}}$  along the  $q$  variable.

Let  $\tilde{g}_N$  be the squeezed symbol (which has a Laurent expansion in  $N$ ), and let  $(a_i)_{i \geq 0}$  a sequence of elements in the expansion of  $\tilde{g}_N$  (both as a Taylor expansion in  $q, p, x, \xi$  and a Laurent expansion in  $N$ ), such that a term of the form  $N^\alpha q^\beta p^\gamma x^\delta \xi^\epsilon$  belongs to  $a_{\alpha - \frac{1}{2}(\beta + \gamma + \delta + \epsilon)}$ . Then  $i < 4$  implies  $a_i = 0$ , and the first non-zero terms are:

$$\begin{aligned} a_4 &= \sum_{i=1}^{n-r} \lambda_i(0)(x_i^2 + \xi_i^2) + \frac{N^{-1}}{2} \operatorname{tr} \left( Q_S + \sum_{i=1}^{n-r} \lambda_i(0) \right) \\ a_5 &= N^{-\frac{1}{4}} q \cdot \nabla_q \left( N^{-1} g_1(\cdot) + \frac{1}{2} \sum_{i=1}^{n-r} \lambda_i(\cdot)(x_i^2 + \xi_i^2) \right) (0) \\ a_6 &= N^{-\frac{1}{2}} \left( Q_S(p) + \operatorname{Hess}(g_1 + \sum_{i=1}^{n-r} \lambda_i)(q) \right) + R_3(x, \xi) + N^{-1} L(x, \xi) \end{aligned}$$

Here  $R_3$  is a homogeneous polynomial of degree 3 and  $L$  is a linear form.

We further write  $A_i = Op_W^{N^{-1}}(a_i)$ .

Let  $\phi$  be the positive quadratic form such that  $e^{-\phi}$  is the ground state (up to a positive factor) of

$$Op_W^1(Q_S(p) + \operatorname{Hess}(g_1 + \sum_{i=1}^{n-r} \lambda_i)(q)),$$

and let

$$u_0^N(q, x) = N^{-n} e^{-N \frac{x^2}{2} - N \phi(q)}.$$

We will provide a sequence of almost eigenfunctions of  $Op_W^{N^{-1}}(\tilde{g}_N)$ , of the form

$$u_0^N(q, x) \left( 1 + \sum_{i=1}^{+\infty} N^{-\frac{i}{4}} b_i(N^{\frac{1}{2}} q, N^{\frac{1}{2}} x) \right),$$

with approximate eigenvalue

$$N^{-1} \sum_{i=0}^{+\infty} \mu_i N^{-\frac{i}{4}}.$$

We proceed by perturbation of the dominant order  $A_4$ , which does not depend on  $q$ . The first eigenvalue  $N^{-1} \mu_0$  of  $A_4$  (as an operator on  $L^2(\mathbb{R}^{n-r})$ ) is simple, so that  $A_4 - N^{-1} \mu_0$  is invertible on  $(x \mapsto \exp(-\frac{N}{2}|x|^2))^\perp$ , with inverse bounded by  $N$ .

Let us solve the successive orders of the equation.

The dominant order of the eigenfunction equation is

$$A_4 u_0 = N^{-1} \mu_0 u_0,$$

which has a unique solution

$$\mu_0 = \sum_{i=1}^{n-r} \lambda_i(0) + \frac{1}{2} \operatorname{tr}(Q_S(0)).$$

Since the function  $g_1 + \sum \lambda_i$  reaches a minimum at  $q = 0$ , one has  $A_5 u_0 = 0$ . The equation on  $b_1$  and  $\mu_1$  is thus

$$(A_4 - N^{-1} \mu_0) b_1 u_0 = N^{-1} \mu_1 u_0,$$

for which the only solution is  $b_1 = 0, \mu_1 = 0$ . Indeed,  $u_0$  belongs to the kernel of  $A_4 - N^{-1} \mu_0$  by definition.

From the expression of  $A_6$ , it is clear that

$$A_6 u_0 = N^{-\frac{3}{2}} f_3(N^{\frac{1}{2}} x) u_0,$$

where  $f_3$  is a polynomial of degree three. By parity,  $\langle A_6 u_0, u_0 \rangle = N^{-\frac{3}{2}} \mu_2 \|u_0\|^2$ , so that  $(A_4 - N^{-1} \mu_0)^{-1} (A_6 - N^{-\frac{3}{2}} \mu_2) u_0 = N^{-\frac{3}{2}} b_2(N^{\frac{1}{2}} x) u_0$  where  $b_2$  is another polynomial of degree three.

All following terms in the expansion are treated in the same fashion, and the proof of the  $L^2$  estimates is standard.  $\square$

### 5.3 Spectral gap

It only remains to show that the sequence of almost eigenfunctions given by the previous proposition corresponds to the first eigenvalue. This is done in a very similar spirit as in [3].

**Proposition 5.7.** *Let  $(\mu_i)$  be the real sequence constructed in the previous proposition, and let  $\mu$  be the first eigenvalue of  $Op^{N^{-1}}(\tilde{g})$ .*

*Then*

$$\mu = N^{-1} \sum_{i=0}^{\infty} N^{-\frac{i}{4}} \mu_i + O(N^{-\infty}).$$

*Moreover, there exists  $c > 0$  such that, for every  $N$ , one has*

$$\operatorname{dist}(\mu, Sp(Op^{N^{-1}})(\tilde{g}) \setminus \{\mu\}) \geq cN^{-\frac{3}{2}}.$$

**Proof.** Let us show that any function orthogonal to the one proposed in the previous proposition has an energy which is larger by at least  $cN^{-\frac{3}{2}}$ .

Let  $(v_N)$  be a sequence of unit vectors in  $L^2(\mathbb{R}^n)$ . If  $\langle v_N, Op^{N^{-1}}(\tilde{g}_N)v_N \rangle \leq N^{-1}\mu_0 + CN^{-\frac{3}{2}}$  for some  $C$ , then  $v_N = N^{\frac{n-r}{4}} e^{-\frac{N|x|^2}{2}} w_N(q) + O(N^{-\frac{1}{2}})$ , with  $\|w_N\|_{L^2} = 1 + O(N^{-\frac{1}{2}})$ .

If  $C - \mu_2$  is strictly smaller than the spectral gap of the quadratic operator

$$Op_W^1(Q_S(0)(p) + \text{Hess } g_1(\cdot, 0, 0, 0)(q)),$$

then  $\langle w_N, N^{-\frac{r}{4}} e^{-NQ(q)} \rangle \geq a$  for some  $a > 0$ , which concludes the proof.  $\square$

## 6 Examples

### 6.1 Crossing of submanifolds

We wish to consider, on  $\mathbb{C}^2$ , the operator with symbol

$$(x_1 + iy_1, x_2 + iy_2) \mapsto y_1^2 + y_2^2 + x_1^2 x_2^2.$$

The minimal set of this operator is  $\{y_1 = y_2 = x_1 = 0\} \cup \{y_1 = y_2 = x_2 = 0\}$ . The characteristic value  $\mu$  is only minimal at the intersection point, which is zero.

We show that, in this example, the behaviour of the ground state is different than in the regular case: here, the speed of concentration along the minimal set is  $N^{-\frac{1}{3}+\epsilon}$ , faster than in the previous case.

**Proposition 6.1.** *The operator  $T_N(y_1^2 + y_2^2 + x_1^2 x_2^2)$  has compact resolvent.*

*Let  $(u_N)_{N \in \mathbb{N}}$  a sequence of unit eigenvectors of the operator  $T_N(y_1^2 + y_2^2 + x_1^2 x_2^2)$  corresponding to the smallest eigenvalue.*

*Then for every  $k$ , there exists  $C_k$  such that, for every  $N$ :*

$$\langle u_N, y^k u_N \rangle \leq C_k N^{-\frac{|k|}{2}}$$

$$\langle u_N, x^k u_N \rangle \leq C_k N^{-\frac{|k|}{3}}.$$

**Proof.** A squeezing of factor  $\lambda$  conjugates  $T_N(y^2)$  into  $\lambda^{-2}T_N(y^2) + \frac{N-1}{2}(1 - \lambda^{-2})$  and  $T_N(x^2)$  into  $\lambda^2 T_N(x^2) + \frac{N-1}{2}(1 - \lambda^2)$ .

Hence, for instance, a squeezing of factor  $\frac{1}{2}$  conjugates  $T_N(y_1^2 + y_2^2 + x_1^2 x_2^2)$  into

$$T_N(4y_1^2 + 4y_2^2 + \frac{3N-1}{8}(x_1^2 + x_2^2) + \frac{1}{4}x_1^2 x_2^2 - 3N^{-1} + \frac{9}{64}N^{-2}).$$

The latter is superior (in the sense of positive operators) to  $T_N(4y_1^2 + 4y_2^2 + \frac{3N-1}{8}(x_1^2 + x_2^2) - 4N^{-1})$ , which has compact resolvent.

**Remark 6.2.** Squeezing back yields:

$$T_N(y_1^2 + y_2^2 + x_1^2 x_2^2) \geq T_N(y_1^2 + y_2^2 + \frac{3N^{-1}}{2}(x_1^2 + x_2^2)) - CN^{-2}.$$

In order to estimate the concentration speed, we will make a different squeezing than considered previously.

Indeed, the squeezing of factor  $N^{\frac{1}{6}}$  conjugates  $T_N(y_1^2 + y_2^2 + x_1^2 x_2^2)$  into

$$T_N(N^{-\frac{1}{3}}(y_1^2 + y_2^2) + N^{\frac{2}{3}}(x_1^2 x_2^2) - \frac{N^{-1}}{2}(N^{\frac{1}{3}} - 1)(x_1^2 + x_2^2) + N^{-1} - \frac{3N^{-\frac{4}{3}}}{4} - \frac{N^{-\frac{5}{3}}}{2} + \frac{N^{-2}}{4}).$$

This is conjugated, via the usual scaling  $\mathcal{B}_N \mapsto \mathcal{B}_1$ , into:

$$T_1(N^{-\frac{4}{3}}(y_1^2 + y_2^2 + x_1^2 x_2^2) - \frac{N^{-\frac{5}{3}} - N^{-2}}{2}(x_1^2 + x_2^2) + C_N).$$

Removing the constant term does not change the eigenvectors, and we let

$$A_N = T_1(N^{-\frac{4}{3}}(y_1^2 + y_2^2 + x_1^2 x_2^2) - \frac{N^{-\frac{5}{3}} - N^{-2}}{2}(x_1^2 + x_2^2)).$$

Let  $v_N$  denote a normalized eigenvector of  $A_N$  with minimal eigenvalue  $\lambda_N$ . Then  $\lambda_N = O(N^{-\frac{4}{3}})$  since

$$N^{-\frac{4}{3}}T_1(y_1^2 + y_2^2 + \frac{1}{4}(x_1^2 + x_2^2)) \leq A_N \leq N^{-\frac{4}{3}}T_1(y_1^2 + y_2^2 + x_1^2 x_2^2).$$

Let us show by induction on  $k \in \mathbb{N}$  that there exists  $C_k$  such that, for every  $N$ , one has  $\langle v_N, |z|^{2k} v_N \rangle \leq C_k$ . The case  $k = 0$  is given by the fact that  $v_N$  is normalized.

Let us suppose that  $\langle v_N, |z|^{2j} v_N \rangle \leq C_j$  for each  $j \leq k$ . As previously one has

$$N^{\frac{4}{3}} \langle z^k v_N, [A_N, z^k] v_N \rangle \leq C_k (\|z^k v_N\|^2 + N^{-1} \|z^{k+1} v_N\|^2),$$

hence

$$N^{\frac{4}{3}} \langle z^k v_N, A_N z^k v_N \rangle \leq C \|z^k v_N\|^2 + N^{-1} C \|z^{k+1} v_N\|^2.$$

Since moreover  $A_N \geq N^{-\frac{4}{3}} T_1(y_1^2 + y_2^2 + \frac{1}{4}(x_1^2 + x_2^2))$ , one can conclude.

Now  $v_N$  is mapped, via the scaling  $\mathcal{B}_N \mapsto \mathcal{B}_1$  and a squeezing, into the ground state of  $T_N(y_1^2 + y_2^2 + x_1^2 x_2^2)$ . Since  $\langle u_N, |y_1|^k u_N \rangle \leq C_k$ , then  $\langle u_N, |y_1|^k u_N \rangle \leq C_k N^{-\frac{k}{2}}$ .

Moreover  $\langle v_N, |x_1|^k v_N \rangle \leq C_k$  so that  $\langle u_N, |x_1|^k u_N \rangle \leq C_k N^{-\frac{k}{3}}$ .  $\square$

## 6.2 Frustrated spin systems

One of the main physical motivations for this study is the mathematical foundation of *quantum selection* in the context of spin systems. The search for materials with a non-conventional magnetic behaviour led physicists to consider frustrated antiferromagnetic spin systems, such as pyrochlore or the Kagome lattice. Even at low spin, these materials exhibit unusual behaviour at low temperatures. In these systems, the high degeneracy of the classical ground state presumably leads to macroscopical quantum effects.

### 6.2.1 Explain

Toeplitz operators include, as a physical illustration, spin systems. In such systems the base manifold is a product of 2-spheres; let  $G = (V, E)$  be a finite graph and  $M = (\mathbb{S}^2)^{\times |G|}$ . At each vertex of the graph one associates a unit vector in  $\mathbb{R}^3$ . As such, consider the  $3|G|$  real functions associating to a given vertex  $i \in G$ , the coordinates  $x_i, y_i, z_i$  of the associated unit vector  $e_i$ . The symplectic structure on  $M$  is such that  $\{x_i, y_j\} = \delta_{ij}z_i$ ; two similar identities hold by cyclic permutation. Let us consider the *antiferromagnetic Heisenberg* symbol:

$$h = \sum_{(i,j) \in E} x_i x_j + y_i y_j + z_i z_j.$$

The classical minimum of this symbol corresponds to situations where the sum of the scalar products between neighbouring vectors is the smallest. If  $G$  is bipartite, this minimum is reached in situations where neighbouring vectors are opposite. In *frustrated systems*, this is not possible. If for instance three vertices in the graph are linked with each other, then each of them cannot be opposite to the other ones. It is the case of the Kagome lattice, and the Husimi cactus, considered in [4].

We will consider a class of graphs “made of triangles”. For a finite connected graph  $G = (E, V)$  to be made of triangles means that  $V = \bigsqcup_{i \in J} V_i$  where, for every  $i$ ,  $V_i$  contains three edges that link together three vertices; we also ask that the degree at any vertex does not exceed 4 (and is hence equal to either 2 or 4). We will call  $V_i$  a triangle of the graph.

### 6.2.2 Description of the zero set

If a graph is made of triangles, the Heisenberg antiferromagnetic symbol is a sum over the triangles of  $u \cdot v + u \cdot w + v \cdot w$ , where  $u, v, w$  are the three elements of  $\mathbb{S}^2$  corresponding to the three vertices of the triangle. This sum



can be written as  $\frac{1}{2}(|u+v+w|^2 - |u|^2 - |v|^2 - |w|^2)$ . Hence, up to a constant, the symbol is the sum over the triangles of the squared norm of the sum of the vectors at the vertices. The way to minimize the symbol is thus to choose the vectors such that, for each triangle in the graph, the vectors at the vertices form a great equilateral triangle on  $\mathbb{S}^2$  (this is equivalent to the requirement that their sum is the zero vector). As the example of the Husimi tree shows, this minimal set can be degenerate: once the vector at a vertex is chosen, there is a  $S^1$  degeneracy in the choice of the vectors at its children.

In the general case, it is not clear that it is possible to choose the vectors such that they form equilateral triangles on each triangle. Even if it is the case, the minimal set is not a submanifold, as we will see in an example.

A subset of interest of the minimal configurations consists in the case where all vectors are coplanar; it corresponds to colouring the graph with three colours. For some of these graphs, there are no 3-colourings. Conversely, if the size of the graph grows the number of three-colourings may grow exponentially fast.

A common conjecture in the physics literature is that, when applicable, the characteristic function  $\mu$  is always minimal only on planar configurations: in other terms, in the semiclassical limit, the quantum state selects only planar configurations. It is unclear whether a study of the sub-subprincipal effects would discriminate further between planar configurations, but numerical evidence suggests that the quantum state is not evenly distributed on them.

Other selection effects tend to select the planar configurations: consider for instance the support of the classical Gibbs measure, at a very small temperature. This measure concentrates on the points of the minimal set where the Hessian has a maximal number of zero eigenvalues (thermal selection); in this case it always corresponds to planar configurations, if any.

The goal of this subsection is the following: we show that, in this class of systems, classical minimal sets are typically not smooth submanifolds. We then generalise some of the results in [4] about “end-point triangles”. More specifically, we prove that, if a triangle has only one neighbouring triangle in such a graph, then the value of  $\mu$  does not depend on the choice of the two spins at the extremity. To conclude, we give an example where numerical evidence suggests a behaviour similar to the toy model considered previously.

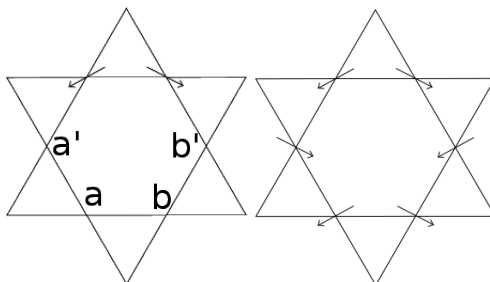

Figure 1: On the left, a graph with 6 triangles and two prescribed vectors. On the right, a particular (planar) configuration.

### 6.2.3 Irregularity of the zero set

One of the key examples of frustrated spin systems is the Kagome lattice. We restrict our study to the case of one loop of six triangles.

Let us show that the minimal set of the antiferromagnetic Heisenberg symbol is not a smooth manifold. The choice of the two drawn vectors on the left in Figure 1 induces a global  $SO(3)$  rotation, and without loss of generality we will keep them fixed. Moreover the position of the six inner triangles determines the position of the six outer triangles in a unique and smooth way, so we will forget about the latter.

The space of configurations of the pair  $(a, a')$  is a subset of a two-dimensional torus; indeed the choice for  $a'$  is made along a circle with center the down-left vector, and the choice for  $a$  is similarly made along a circle with center  $a'$ . The above applies to the pair  $(b, b')$ . Hence the set of global configurations is a subset of a four-dimensional torus: the subset on which the angle between  $a$  and  $b$  is exactly  $\frac{2\pi}{3}$ . This cannot be an open set of the four-dimensional torus, as every coordinate and function involved is real analytic. Hence, if this set is a smooth manifold, its dimension does not exceed three.

On the other hand, consider the particular case of Figure 1 which represents a particular configuration. From this configuration, one stays in the minimal set by moving  $a'$  along a circle with center  $a$ ; one can also move along  $a$  only, or along  $b$  only, or along  $b'$  only. The set of possible smooth moves from this configuration spans a set of dimension at least four, hence the contradiction.

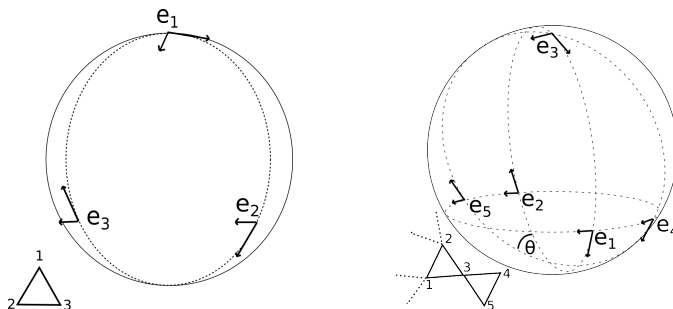

Figure 2: General minimal configuration for one triangle (left) and an end-point triangle (right) of spins, with choice of tangent coordinates.

#### 6.2.4 Degeneracy for end-point triangles

The simplest example of a frustrated system is a triangle with three vertices, connected with each other. In this setting the degeneracy of the minimal set (which is exactly the set of configurations such that the sum of the three vectors is zero) corresponds to a global  $SO(3)$  symmetry of the problem; in this case the function  $\mu$  is constant.

Consider the left part of Figure 2. The three elements  $e_1, e_2, e_3$  lie on the same large circle. The coordinate  $q_i$  is along this circle and the coordinate  $p_i$  is orthogonal to it. In these coordinates, the quadratic form can be written as:

$$2(p_1 + p_2 + p_3)^2 + (q_1 - q_2)^2 + (q_1 - q_3)^2 + (q_2 - q_3)^2.$$

Consider a graph with an “end-point triangle” as in figure 2, on the right. In order to find a classical minimum for such a graph, once all vectors except for  $e_4$  and  $e_5$  are chosen, those two move freely along a circle centered on  $e_3$ . We claim that this choice does not change  $\mu$ .

Denoting  $c = \cos(\theta)$  and  $s = \sin(\theta)$ , and using local coordinates as in the right part of Figure 2, the 2-jet of the Hamiltonian reads, in local coordinates:

$$\begin{aligned} Q(p_1, p_2, q_1, q_2, \dots) &+ 2(p_4 + p_5)^2 + (q_4 - q_5)^2 + q_4^2 + q_5^2 + 4q_3^2 + 4p_3^2 \\ &+ 4p_3(p_1 + p_2) - 2q_3(q_1 + q_2) \\ &+ 4cp_3(p_4 + p_5) - 4sq_3(p_4 + p_5) \\ &\quad - 2cq_3(q_4 + q_5) - 2sp_3(q_4 + q_5). \end{aligned}$$

The trace of this quadratic form does not depend on  $\theta$ . Hence, in order to prove that  $\mu$  does not depend on  $\theta$  it is sufficient to find symplectic

coordinates in which this quadratic form does not depend on  $\theta$ . A first symplectic change of variables leads to:

$$\begin{aligned} Q(p_1, p_2, q_1, q_2, \dots) &+ 4p_4^2 + q_4^2 + 3q_5^2 + 4q_3^2 + 4p_3^2 \\ &+ 4p_3(p_1 + p_2) - 2q_3(q_1 + q_2) \\ &+ 4\sqrt{2}cp_3p_4 - 4\sqrt{2}s q_3p_5 - 2\sqrt{2}cq_3q_5 - 2\sqrt{2}sp_3q_5. \end{aligned}$$

Let us make the following change of variables:

$$\begin{aligned} p_4 &\mapsto cp_4 - s\frac{q_5}{2} \\ q_5 &\mapsto cq_5 + 2sp_4 \\ p_5 &\mapsto cp_5 + s\frac{q_4}{2} \\ q_4 &\mapsto cq_4 - 2sp_5. \end{aligned}$$

This change of variables is symplectic, and preserves  $4p_4^2 + q_5^2$  as well as  $4p_5^2 + q_4^2$ . The quadratic form becomes:

$$\begin{aligned} Q(p_1, p_2, q_1, q_2, \dots) &+ 4p_3(p_1 + p_2) - 2q_3(q_1 + q_2) \\ &+ 4p_4^2 + q_4^2 + 3q_5^2 + 4p_3^2 + 4q_3^2 + 8p_3p_4 - 4q_5q_3. \end{aligned}$$

This quadratic form does not depend on  $\theta$ , hence  $\mu$  does not depend on  $\theta$ .

The last example we treat is the case of a loop of 4 triangles. In this setting, the minimal set is not a submanifold but a union of three submanifolds, with transverse intersection.

The quadratic form is again explicit if the local coordinates are chosen conveniently, but computing  $\mu$  depends on an exact diagonalization which is much harder than in the previous case.

A numerical plot of  $\mu$  as a function of  $\theta$  is presented in Figure 4. Note that  $\mu$  is not smooth, as warned in [8]. We believe that a closed expression of  $\mu$  is, in this case, rather technical to obtain. The Figure 4 is a strong indication that  $\mu$  is only minimal on flat configurations.

## References

- [1] L. Charles. Berezin-Toeplitz Operators, a Semi-Classical Approach. *Communications in Mathematical Physics*, 239(1-2):1–28, Aug. 2003.

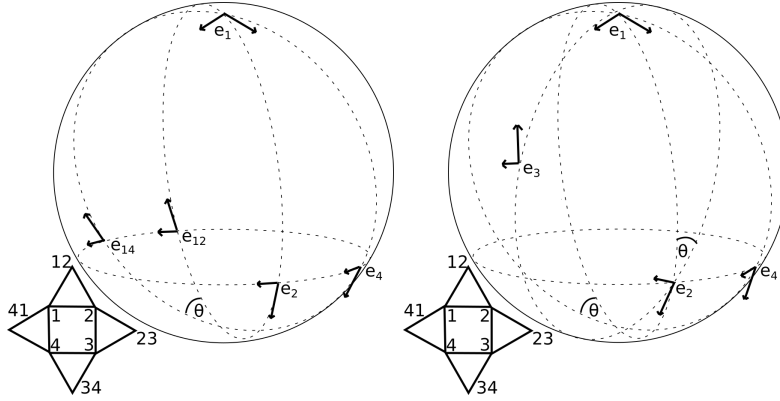

Figure 3: The two general configurations for a loop of 4 triangles. For the first configuration,  $e_3 = e_1$  so  $e_{12} = e_{23}$  and  $e_{14} = e_{34}$ . In the second configuration, for simplicity we omitted to draw  $e_{12}, e_{23}, e_{34}$  and  $e_{14}$ .

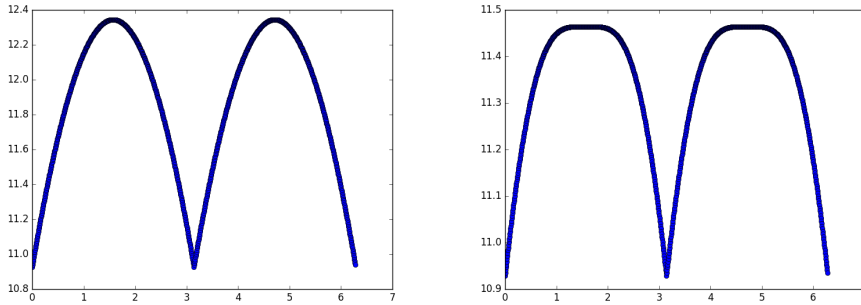

Figure 4: Numerical plot of the value of  $\mu$  as a function of  $\theta$  in the two situations corresponding to figure 3. In both cases the minimum is reached on planar configurations, with a minimal value  $\mu \simeq 10.928$

- [2] L. Charles. Semi-classical properties of geometric quantization with metaplectic correction. *Communications in mathematical physics*, 270(2):445–480, 2007.
- [3] A. Deleporte. Low-energy spectrum of Toeplitz operators: the case of wells. *arXiv preprint arXiv:1609.05680*, 2016.
- [4] B. Douçot and P. Simon. A semiclassical analysis of order from disorder. *Journal of Physics A: Mathematical and General*, 31(28):5855, 1998.
- [5] B. Helffer and J. Sjöstrand. Puits multiples en limite semi-classique V : Étude des minipuits. *Current topics in partial differential equations*, pages 133–186, 1986.
- [6] L. Hörmander. *The Analysis of Linear Partial Differential Operators III*. Classics in Mathematics. Springer, 2007.
- [7] X. Ma and G. Marinescu. *Holomorphic Morse inequalities and Bergman kernels*, volume 254. Springer Science & Business Media, 2007.
- [8] A. Melin. Lower bounds for pseudo-differential operators. *Arkiv för Matematik*, 9(1):117–140, 1971.
- [9] B. Shiffman and S. Zelditch. Asymptotics of almost holomorphic sections on symplectic manifolds. *J. reine angew. Math.*, 544:181–222, 2002.
- [10] N. M. J. Woodhouse. *Geometric quantization*. Oxford University Press, 1997.