



**HAL**  
open science

## **Origin : a 60 GHz radio-over-fiber home area network project**

Camilla Kärnfelt, Michel Ney, Daniel Bourreau, Adonis Bikiny, Gaetan Guevel, Yannick Paugam, François Gallée, Joffray Guillory, Anna Pizzinat, Benoît Charbonnier, et al.

### ► **To cite this version:**

Camilla Kärnfelt, Michel Ney, Daniel Bourreau, Adonis Bikiny, Gaetan Guevel, et al.. Origin : a 60 GHz radio-over-fiber home area network project. International symposium on Green Radio over Fiber & All optical Technologies for Wireless Access Networks (GROWAN 2011), Jun 2011, Brest, France. hal-01381709

**HAL Id: hal-01381709**

**<https://hal.science/hal-01381709>**

Submitted on 14 Oct 2016

**HAL** is a multi-disciplinary open access archive for the deposit and dissemination of scientific research documents, whether they are published or not. The documents may come from teaching and research institutions in France or abroad, or from public or private research centers.

L'archive ouverte pluridisciplinaire **HAL**, est destinée au dépôt et à la diffusion de documents scientifiques de niveau recherche, publiés ou non, émanant des établissements d'enseignement et de recherche français ou étrangers, des laboratoires publics ou privés.

## FUI8-ORIGIN (Optical-Radio Infrastructure for Gigabit/s Indoor Network)

### Authors

C. Karnfelt<sup>1</sup>, M. Ney<sup>1</sup>,  
 D. Bourreau<sup>1</sup>, A. Bikiny<sup>1</sup>,  
 G. Guével<sup>1</sup>, Y. Paugam<sup>1</sup>,  
 F. Gallée<sup>1</sup>, J. Guillory<sup>2</sup>,  
 A. Pizzinat<sup>2</sup>, B. Charbonnier<sup>2</sup>,  
 S. Meyer<sup>2</sup>, O. Bouffant<sup>2</sup>,  
 G. Delas<sup>2</sup>, H.W.Li<sup>3</sup>,  
 E. Tanguy<sup>3</sup>, M. Brunet<sup>3</sup>,  
 G. Lirzin<sup>3</sup>, A. Chousseaud<sup>3</sup>,  
 C. Algani<sup>4</sup>, A-L. Billabert<sup>4</sup>,  
 J-L Polleux<sup>4</sup>, C. Canepa<sup>5</sup>,  
 G. Gougeon<sup>6</sup>, V. Gouin<sup>7</sup>

### Partners

- 1) Télécom Bretagne, Microwave department, Lab-STICC UMR CNRS 3192, Brest
- 2) Orange Labs, Lannion
- 3) IREENA, Nantes
- 4) ESYCOM, Paris
- 5) ACOME, Mortain
- 6) SIRADEL, Rennes
- 7) NIJI, Rennes

## 60 GHz IN THE HOME

- Multiservice and multiuser system for the future home
- Multi Gigabit/s capacity
- 60 GHz standards for wireless use are now being finalized and adopted
- 60 GHz indoor implies limited coverage (i.e. one room), need of low-loss infrastructure to dispatch signal across walls
- Multipoint-to-Multipoint (Mpt-to-Mpt) system architecture

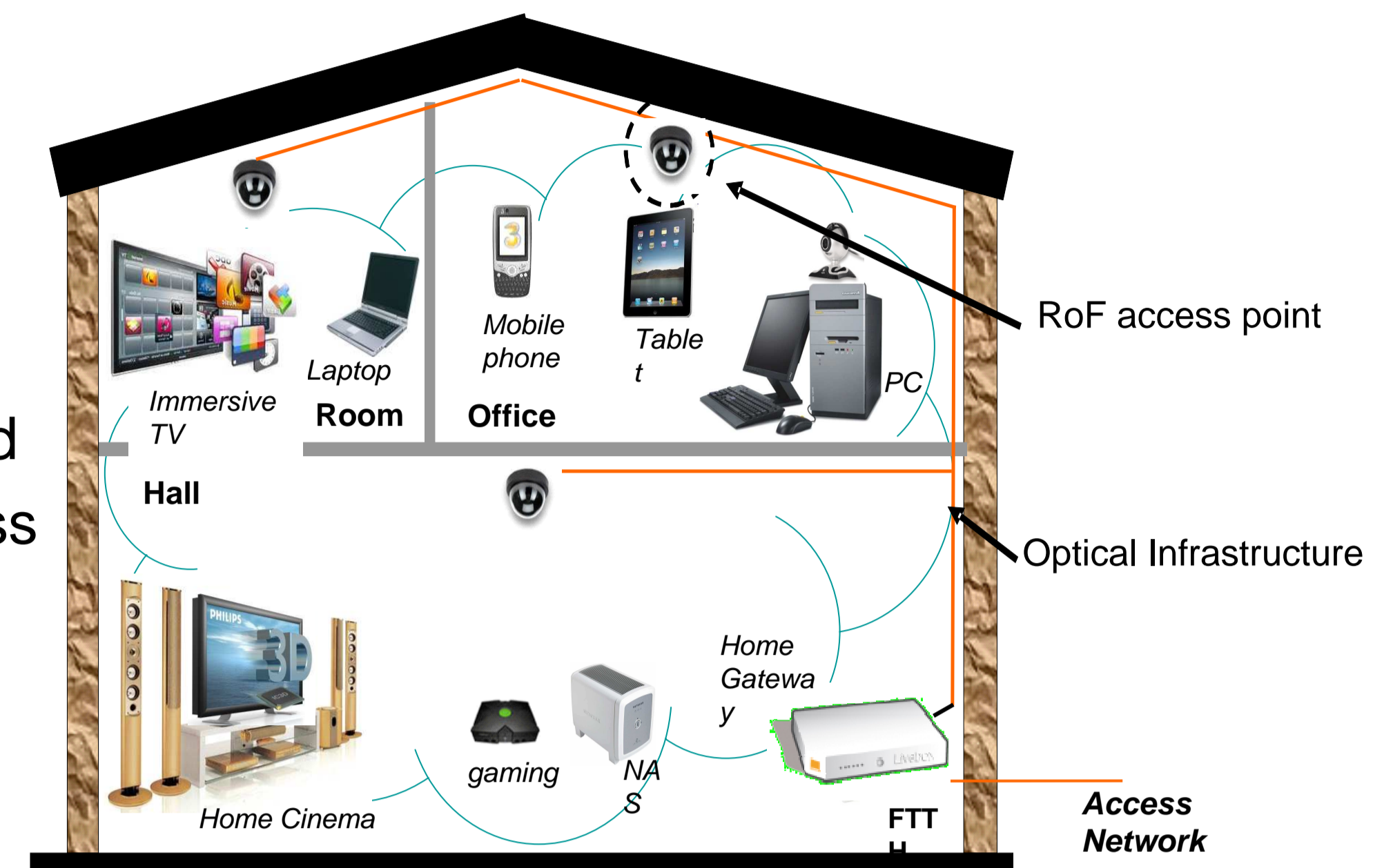

## ORIGIN SYSTEM ARCHITECTURE

- To dispatch the signal to all rooms a low cost HAN RoF infrastructure is proposed
- The HAN RoF infrastructure is transparent to different standards
- The received 60 GHz radio signal is down-converted to 5 GHz before its transfer on optical fiber and then up-converted to 60 GHz before wireless transmission
- Reduced electromagnetic radiation and power consumption (access points only activated when needed)

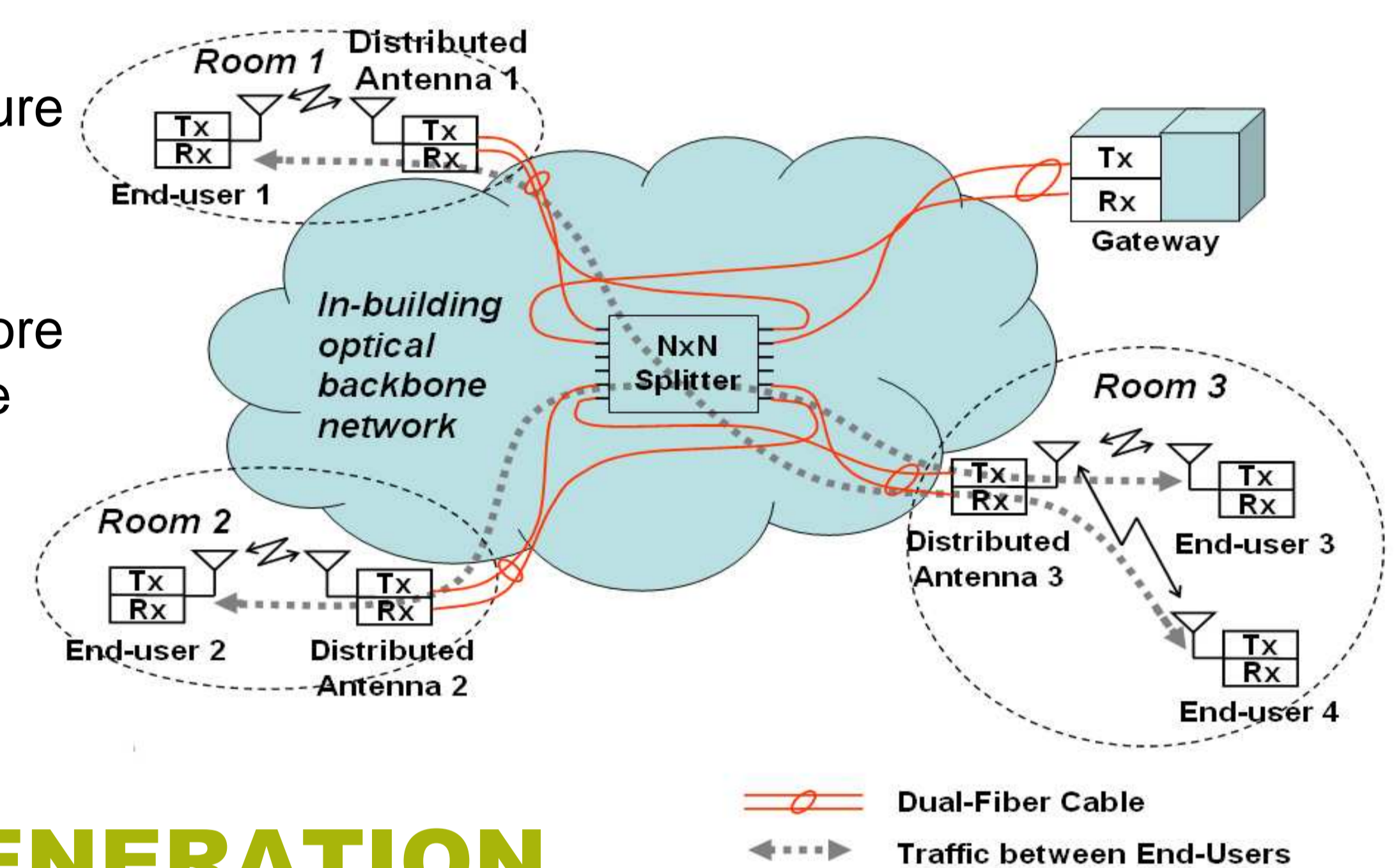

## HARDWARE DEVELOPMENT : 1<sup>st</sup> GENERATION

- VCSELs, photodiodes, cables, antennas, mm-wave and cm-wave TX and RX modules
- A pre-industrialized demonstrator (6 rooms) will be implemented and tested at the end of the project

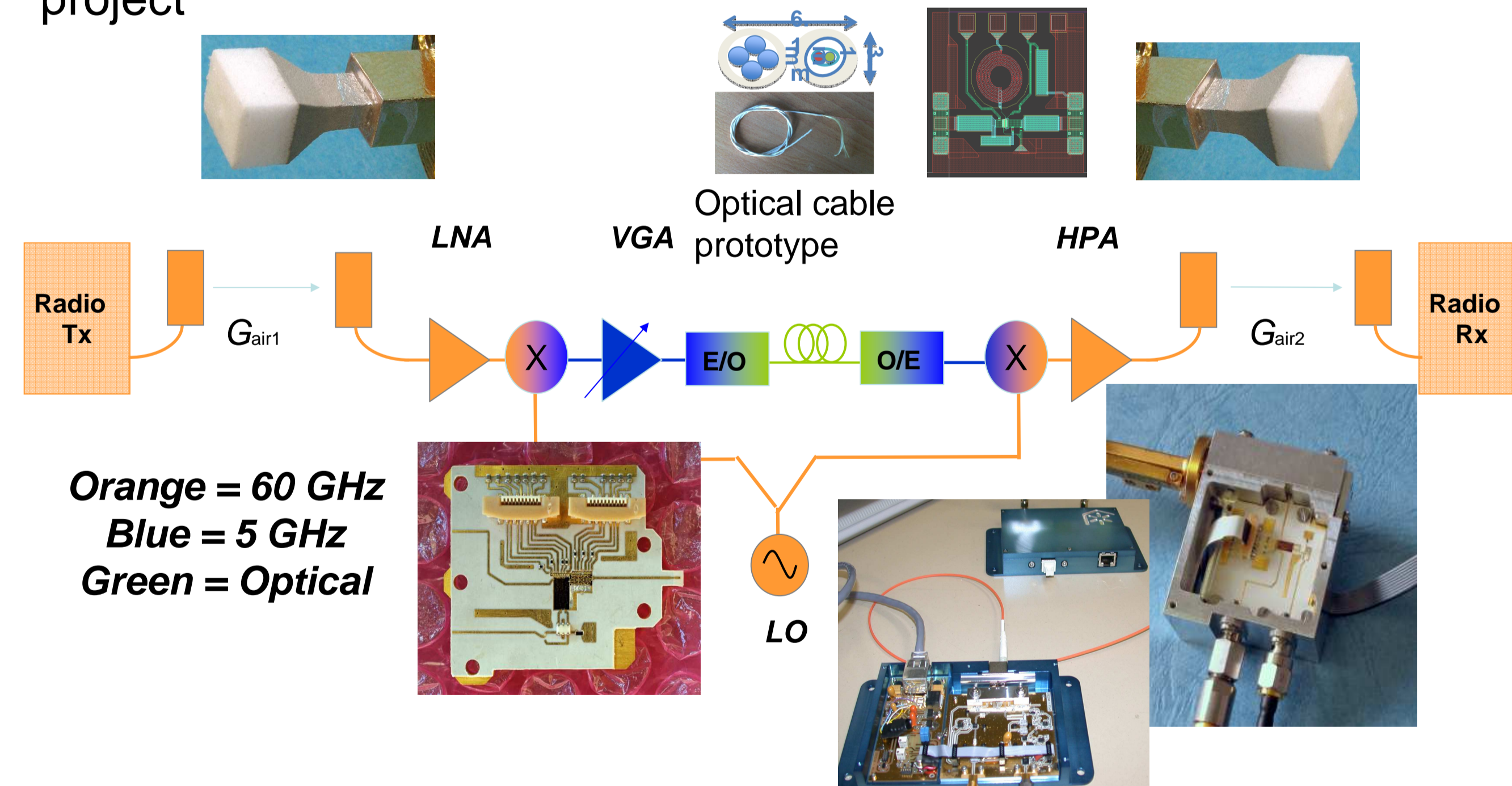

Transmission result for first RoF prototype.  
 • Protocol IEEE802.15.3c High Speed Interface mode

	NA	5	7.5	10
Free space dist (m)	NA	5	7.5	10
EVM (%)	5	19	22	25

## MILLIMETER-WAVE MODULES

### Antenna

- Low cost foam technology
- >7 dBi Gain at 60 GHz
- Return loss > 20 dB from 57 to 65 GHz

### RX/TX modules

- Rogers 4003 substrate
- MMICs with chip-and-wire technology
- DC management
- Antenna interfaced by waveguide

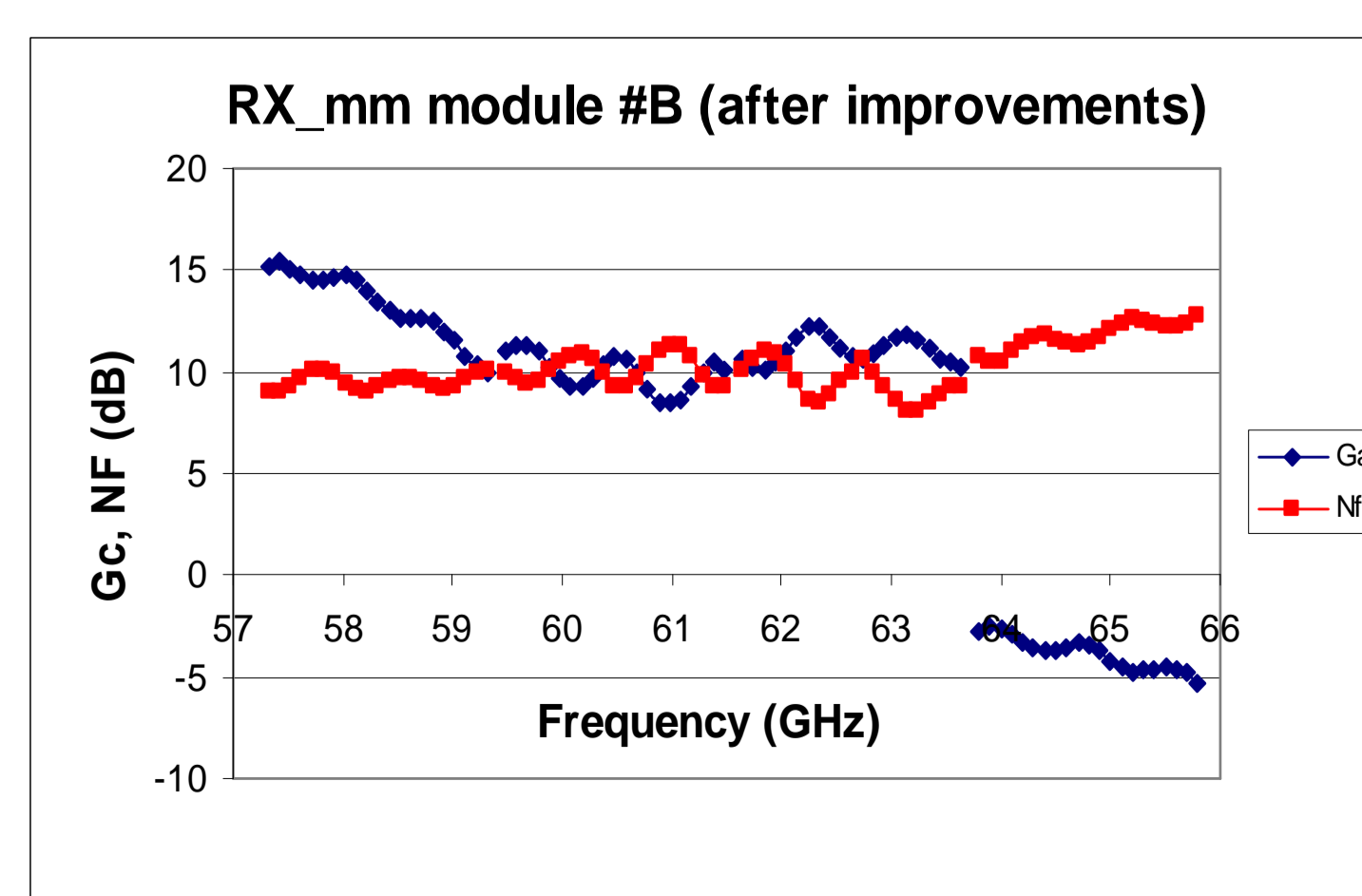
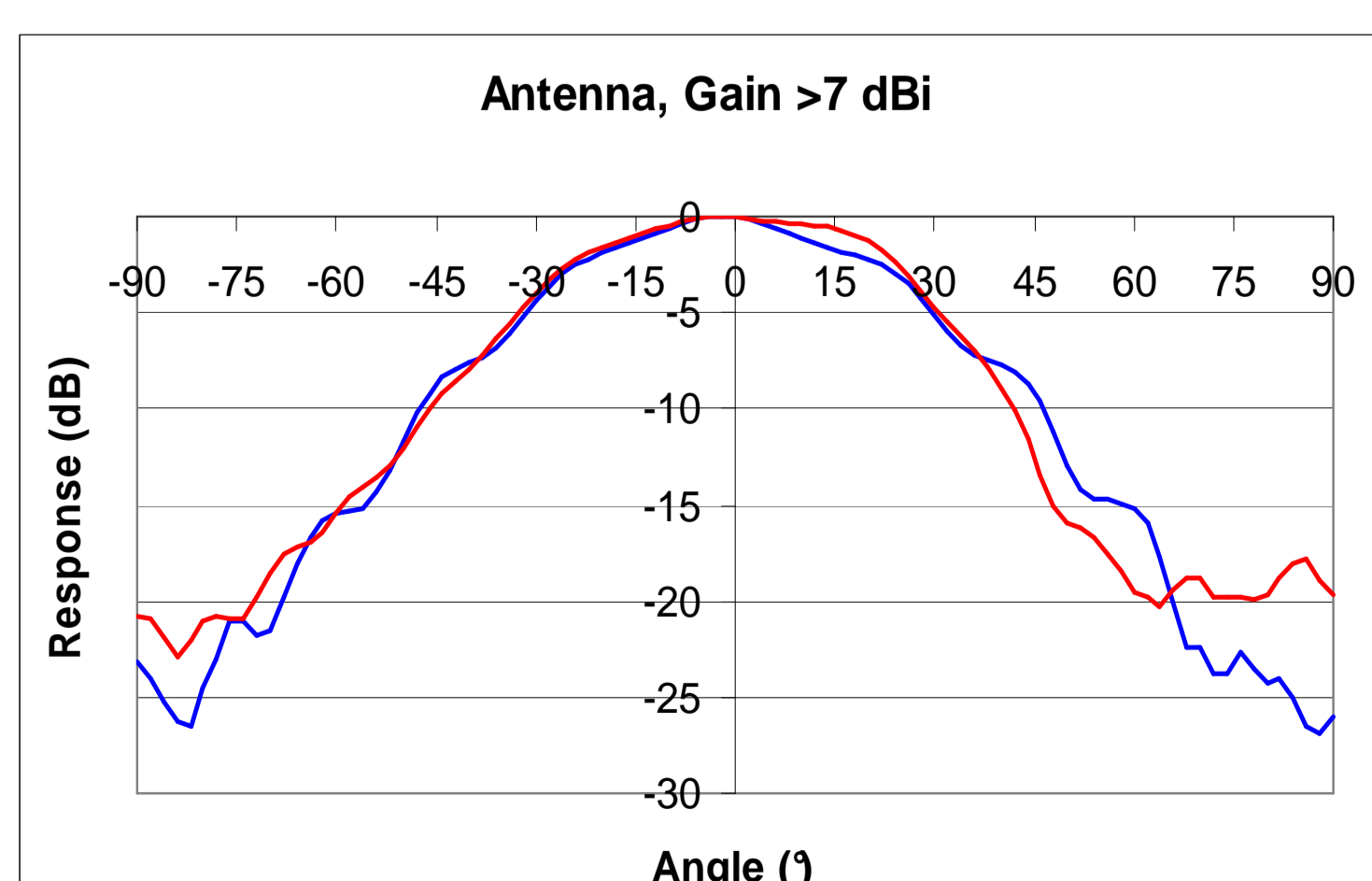

### Further work:

#### 2<sup>nd</sup> and 3<sup>rd</sup> generation

- RX: Improve NF
- TX: Improve LO rejection
- Minimize modules
- Further integration between cm- and mm-wave parts

