



HAL
open science

On bipartite unitary matrices generating subalgebra-preserving quantum operations

Tristan Benoist, Ion Nechita

► **To cite this version:**

Tristan Benoist, Ion Nechita. On bipartite unitary matrices generating subalgebra-preserving quantum operations. *Linear Algebra and its Applications*, 2017, 521, pp.70-103. 10.1016/j.laa.2017.01.020 . hal-01381093

HAL Id: hal-01381093

<https://hal.science/hal-01381093v1>

Submitted on 8 Jan 2024

HAL is a multi-disciplinary open access archive for the deposit and dissemination of scientific research documents, whether they are published or not. The documents may come from teaching and research institutions in France or abroad, or from public or private research centers.

L'archive ouverte pluridisciplinaire **HAL**, est destinée au dépôt et à la diffusion de documents scientifiques de niveau recherche, publiés ou non, émanant des établissements d'enseignement et de recherche français ou étrangers, des laboratoires publics ou privés.

ON BIPARTITE UNITARY MATRICES GENERATING SUBALGEBRA-PRESERVING QUANTUM OPERATIONS

TRISTAN BENOIST AND ION NECHITA

ABSTRACT. We study the structure of bipartite unitary operators which generate via the Stinespring dilation theorem, quantum operations preserving some given matrix algebra, independently of the ancilla state. We characterize completely the unitary operators preserving diagonal, block-diagonal, and tensor product algebras. Some unexpected connections with the theory of quantum Latin squares are explored, and we introduce and study a Sinkhorn-like algorithm used to randomly generate quantum Latin squares.

CONTENTS

1. Introduction	1
2. Quantum channels and invariant subalgebras	3
3. Structures arising from partial isometries	4
4. The diagonal algebra	6
4.1. The Heisenberg picture	6
4.2. The Schrödinger picture	8
5. The block-diagonal algebra	9
5.1. The Heisenberg picture	10
5.2. The Schrödinger picture	11
5.3. Comparing subalgebras	12
6. The tensor product algebra	13
6.1. The Heisenberg picture	14
6.2. The Schrödinger picture	15
6.3. Comparing subalgebras	17
7. Zero block algebra	18
8. Generating random structured bipartite unitary operators	19
Appendix A. A non-commutative Sinkhorn algorithm: the invertible case	22
References	24

1. INTRODUCTION

States of finite dimensional quantum systems are described by trace one, positive semidefinite matrices called *density matrices*. Their evolution is given by completely positive trace preserving maps (CPTP), also called *quantum channels*. For *closed* systems, the Quantum channel consists in the left and right multiplication by a unitary matrix and its hermitian conjugate respectively. Quantum channels describing the evolution of a system in contact with an environment, the so-called *open* quantum systems, are given by more general CPTP maps. The famous Stinespring dilation theorem [19] connects the mathematical definition of open system evolution quantum channels with their physical interpretation: the evolution of an open quantum system can be seen as the

closed evolution of a [system + environment] bipartite system, followed by the discarding (or partial tracing) of the environment:

$$\rho \mapsto T(\rho) = [\text{id} \otimes \text{Tr}](U(\rho \otimes \beta)U^*).$$

Hence, the quantum evolution depends on two physical relevant parameters: the global evolution operator U and the state of the environment subsystem β . We would like to identify the part played by the unitary interaction U in the properties of the quantum channel T . Namely, we would like to characterize families of bipartite unitary matrices U such that the quantum channels T they generate have some prescribed properties, independently of the environment state β . In this work, we answer this question for channels preserving some special sub-algebras of states/observables. Different channel properties were studied under the same framework in [11] (see also [4]).

Part of the initial motivation of our study originates in the characterization of quantum channels preserving a set of *pointer* states. These CPTP maps appear in the context of quantum non demolition measurements [6, 7, 8, 2, 21, 20]. The following proposition is a discrete time version of [8, Theorem 3]. It is obtained through the repeated application of Theorem 7.1.

Proposition 1.1. *Let $\{e_i\}_{i=1}^n$ be a fixed orthonormal basis of \mathbb{C}^n , and $U \in \mathcal{U}_{nk}$ a bipartite unitary operator. The following statements are equivalent:*

- (1) *There exists a set of quantum states \mathcal{B} which spans $M_k(\mathbb{C})$ such that, for any state $\beta \in \mathcal{B}$, the quantum channel $T_{U,\beta}$ leaves invariant the basis states $e_i e_i^*$:*

$$\forall \beta \in \mathcal{B}, \forall i \in [n], \quad T_{U,\beta}(e_i e_i^*) = e_i e_i^*;$$

- (2) *The operator U is block-diagonal, i.e. there exists unitary operators $U_1, \dots, U_n \in \mathcal{U}_k$ such that*

$$U = \sum_{i=1}^n e_i e_i^* \otimes U_i.$$

The implication (1) \implies (2) holds also if (1) is replaced by

$$\exists \beta > 0, \forall i \in [n], \quad T_{U,\beta}(e_i e_i^*) = e_i e_i^*.$$

The main goal of the current paper is to obtain similar characterization of the set of bipartite unitary operators giving quantum operations which preserve some structure on the input state or observable, such as diagonal matrices, tensor products, or other block-structures. One of our main results is a characterization of quantum channels creating no coherences between states of a prescribed basis. They therefore act essentially classically. More precisely we characterize bipartite unitary matrices generating CPTP maps preserving quantum states which are diagonal in the computation basis (see Theorem 4.4 for a precise statement):

Theorem. *A bipartite unitary operator U acting on $\mathbb{C}^n \otimes \mathbb{C}^k$ generates quantum channels T which, independently of the environment state β , leave invariant the diagonal subalgebra D_n if and only if its blocks $\{U_{ij}\}_{i,j=1}^n$ are partial isometries with initial and final spaces E_{ij} and F_{ij} respectively satisfying the following conditions:*

- *For all rows i , the collection of final spaces $\{F_{ij}\}_j$ forms an orthogonal partition of \mathbb{C}^k*
- *For all columns j , both collections of initial spaces $\{E_{ij}\}_i$ and of final spaces $\{F_{ij}\}_i$ form orthogonal partitions of \mathbb{C}^k .*

In the result above, the collection of final spaces of the partial isometries $\{F_{ij}\}_{ij}$, is required to partition the total space \mathbb{C}^k simultaneously on every row and column. In the case where each space F_{ij} is of dimension one, this is precisely the definition of *quantum Latin squares* from [14]. We analyze further these objects and we propose an algorithm to randomly sample such objects. We analyze numerically this algorithm (inspired by the classical Sinkhorn algorithm) and prove the convergence of a relaxed version of it.

The paper is organized as follows. In Section 2 we set up the problem we are studying, giving the necessary definitions. In Section 3 we gather some useful facts about partial isometries which shall be necessary later on. The next four sections represent the core of the paper and contain the results about, respectively, diagonal, block-diagonal, tensor product, and zero algebras. The proofs for the preservation of diagonal or block diagonal algebra and tensor product algebra use incompatible techniques, we thus do not provide a characterization of bipartite unitary matrices generating quantum channels preserving direct sum of tensor product sub-algebras. Section 8 contains some numerical recipes to sample from the sets of unitary operators considered in this paper. Finally, the Appendix contains the proof of the non-commutative Sinkhorn algorithm in the case where the blocks of the matrix are invertible.

Acknowledgments. I.N. would like to thank Teo Banica and Martin Idel for inspiring discussions around Sinkhorn's algorithm and its different generalizations. The authors' research has been supported by the ANR projects RMTQIT ANR-12-IS01-0001-01 and StoQ ANR-14-CE25-0003-01. Both authors acknowledge the hospitality of the Mathematical Physics Chair of the Technische Universität München, where this research was initiated.

2. QUANTUM CHANNELS AND INVARIANT SUBALGEBRAS

In this paper, we are interested in the structure of bipartite unitary operators $U \in \mathcal{U}_{nk}$, and of the quantum operations they generate via dilation results. To any such bipartite unitary operator and any trace one positive semidefinite matrix $\beta \in M_k(\mathbb{C})$, we associate two maps:

$$\begin{aligned} S_{U,\beta} : M_n(\mathbb{C}) &\rightarrow M_n(\mathbb{C}) \\ X &\mapsto [\text{id} \otimes \text{Tr}](U^*(X \otimes I_k)U(I_n \otimes \beta)) \end{aligned} \quad (1)$$

and

$$\begin{aligned} T_{U,\beta} : M_n(\mathbb{C}) &\rightarrow M_n(\mathbb{C}) \\ X &\mapsto [\text{id} \otimes \text{Tr}](U(X \otimes \beta)U^*) \end{aligned} \quad (2)$$

If the matrix β is a quantum state, i.e. $\beta \in M_k^{1,+}(\mathbb{C})$, the map $S_{U,\beta}$ is unital and completely positive (UCP), while the map $T_{U,\beta}$ is trace preserving and completely positive (TPCP). Moreover, a direct calculation shows that the maps above are dual with respect to the Hilbert-Schmidt scalar product:

$$\forall X, Y \in M_n(\mathbb{C}), \quad \langle S_{U,\beta}(X), Y \rangle = \langle X, T_{U,\beta}(Y) \rangle.$$

We refer the reader to [16, Chapter 6] for a mathematical introduction to CP maps, and to [15, Chapter 8] or [22] for a quantum information theory perspective.

Our ultimate goal will be to characterize bipartite unitary operators U with the property that *all* the UCP maps $S_{U,\beta}$ (respectively all quantum channels $T_{U,\beta}$) preserve a C^* -algebra

$$\mathcal{A} = 0_{d_0} \oplus \bigoplus_{i=1}^N (M_{d_i}(\mathbb{C}) \otimes I_{r_i}). \quad (3)$$

Note that the above expression is, up to a global unitary rotation, the most general form of a C^* -subalgebra of $M_n(\mathbb{C})$, see [10, Theorem I.10.8]. The diagonal subalgebra corresponds to the case $d_0 = 0$, $d_i = r_i = 1$, for $i \in [N]$ (for an integer n , we write $[n] := \{1, 2, \dots, n\}$). More precisely, we shall be interested in the sets

$$\begin{aligned} \mathcal{U}^{(\mathcal{A},H)} &:= \{U \in \mathcal{U}_{nk} : \forall \beta \in M_k^{1,+}(\mathbb{C}), S_{U,\beta}(\mathcal{A}) \subseteq \mathcal{A}\} \\ \mathcal{U}^{(\mathcal{A},S)} &:= \{U \in \mathcal{U}_{nk} : \forall \beta \in M_k^{1,+}(\mathbb{C}), T_{U,\beta}(\mathcal{A}) \subseteq \mathcal{A}\} \end{aligned}$$

of bipartite unitary operators leaving the subalgebra \mathcal{A} invariant in the Heisenberg, respectively the Schrödinger picture. We shall also be interested in comparing the sets above corresponding to two subalgebras $\mathcal{A}_1 \subseteq \mathcal{A}_2 \subseteq M_n(\mathbb{C})$. In general, we have the following inclusion diagram

$$\begin{array}{ccc} \{U : \forall \beta, S_{U,\beta}(\mathcal{A}_1) \subseteq \mathcal{A}_1\} & \subseteq & \{U : \forall \beta, S_{U,\beta}(\mathcal{A}_1) \subseteq \mathcal{A}_2\} \\ \cup & & \cup \\ \{U : \forall \beta, S_{U,\beta}(\mathcal{A}_2) \subseteq \mathcal{A}_1\} & \subseteq & \{U : \forall \beta, S_{U,\beta}(\mathcal{A}_2) \subseteq \mathcal{A}_2\} \end{array}$$

Similar relations hold for channels in the Schrödinger picture. Note that the above diagram does not imply any obvious relations between the sets $\mathcal{U}^{(\mathcal{A}_1, H/S)}$ and $\mathcal{U}^{(\mathcal{A}_2, H/S)}$; some special cases of algebra inclusions will be investigated in Sections 5.3 and 6.3, to show that these sets are, in general, not comparable.

3. STRUCTURES ARISING FROM PARTIAL ISOMETRIES

Recall that a *partial isometry* between two Hilbert spaces is a map such that its restriction to the orthogonal of its kernel is an isometry. More precisely, a matrix $R \in M_n(\mathbb{C})$ is a partial isometry if there exists two subspaces E and F , called respectively the *initial* and the *final subspace* of R , such that

- (1) $\ker R = E^\perp$;
- (2) $R : E \rightarrow F$ is an isometry.

Partial isometries are characterized by the relation $R = RR^*R$ (or, equivalently, by the relation $R^* = R^*RR^*$). Let us remark right away that two important classes of operators, orthogonal projections and unitary operators, are partial isometries.

Definition 3.1. A family of vector subspaces $\{E_i\}_{i \in I}$ is said to form a partition of \mathbb{C}^k if

- (1) For all $i \neq j \in I$, we have $E_i \perp E_j$;
- (2) $\bigoplus_{i \in I} E_i = \mathbb{C}^k$.

Definition 3.2. An operator $R \in M_{nk}(\mathbb{C}) \cong M_n(M_k(\mathbb{C}))$ is called a matrix of partial isometries if its blocks $R_{ij} \in M_k(\mathbb{C})$ defined by

$$R = \sum_{i,j=1}^n e_i e_j^* \otimes R_{ij}$$

are partial isometries. Let E_{ij} (resp. F_{ij}) be the initial (resp. final) spaces of the partial isometries R_{ij} . The matrix of partial isometries R is said to be of type (x, y, z, \dots) if, in addition, the subspaces E_{ij}, F_{ij} satisfy the orthogonality conditions x, y, z, \dots from the list below:

- (C1) For all $i \in [n]$, the subspaces $\{E_{ij}\}_{j \in [n]}$ form a partition of \mathbb{C}^k ;
- (C2) For all $i \in [n]$, the subspaces $\{F_{ij}\}_{j \in [n]}$ form a partition of \mathbb{C}^k ;
- (C3) For all $j \in [n]$, the subspaces $\{E_{ij}\}_{i \in [n]}$ form a partition of \mathbb{C}^k ;
- (C4) For all $j \in [n]$, the subspaces $\{F_{ij}\}_{i \in [n]}$ form a partition of \mathbb{C}^k .

Lemma 3.3. A matrix of partial isometries is unitary iff it is of type (C2),(C3).

Proof. Let R be a matrix of partial isometries of type (C2),(C3), with blocks R_{ij} . We have

$$RR^* = \sum_{i,j=1}^n e_i e_j^* \otimes \sum_{s=1}^n R_{is} R_{js}^*.$$

Consider now a general term $R_{is} R_{js}^*$ in the sum above. The map R_{js}^* is also a partial isometry, having initial space F_{js} and final space E_{js} . Since, for all s , the spaces $\{E_{rs}\}_{r \in [n]}$ form a partition

of \mathbb{C}^k , we obtain $R_{is}R_{js}^* = \delta_{ij}P_{F_{is}}$ (P_V denotes the orthogonal projection onto some subspace V). Hence

$$RR^* = \sum_{i=1}^n e_i e_i^* \otimes \sum_{s=1}^n P_{F_{is}} = \sum_{i=1}^n e_i e_i^* \otimes I_k = I_{nk},$$

where we have used again the direct sum hypothesis for the partition $\{F_{is}\}_{s \in [n]}$.

Reciprocally, consider now a unitary operator U and represent it by blocks (which are partial isometries)

$$U = \sum_{i,j=1}^n e_i e_j^* \otimes U_{ij}.$$

From the unitarity condition $UU^* = I_{nk}$, we get that, for all $i \in [n]$,

$$I_k = \sum_{j=1}^n U_{ij}U_{ij}^* = \sum_{j=1}^n P_{F_{ij}}.$$

But a sum of selfadjoint projections is equal to the identity iff the subspaces of the projections form a partition of the total space. Hence, we obtain that, for all i , the subspaces $\{F_{ij}\}_{j \in [n]}$ form a partition of \mathbb{C}^k , which is condition (C2) from Definition 3.2. Starting from the relation $U^*U = I_{nk}$, a similar reasoning produces condition (C3) from the statement. \square

The proofs of the upcoming sections are based on the following lemma, due to Cochran [9].

Lemma 3.4. *Let $A_1, \dots, A_n \in M_k(\mathbb{C})$ be operators satisfying*

$$\sum_{i=1}^n A_i^* A_i = I. \quad (4)$$

Then,

$$\sum_{i=1}^n \text{rk}(A_i) \geq k, \quad (5)$$

with equality iff the A_i are partial isometries with initial spaces E_i forming a partition of \mathbb{C}^k .

Proof. The rank sum inequality (5) is a consequence of the rank subadditivity and the equality $\text{rk}(A^*A) = \text{rk}(A)$ for any matrix $A \in M_k(\mathbb{C})$.

The fact that if the A_i 's are partial isometries with initial spaces forming a partition of \mathbb{C}^k then $\sum_{i=1}^n \text{rk}(A_i) = k$ and $\sum_{i=1}^n A_i^* A_i = I$ follows directly from $A_i^* A_i = P_{E_i}$ and $\text{rk}(A_i) = \dim(E_i)$ by the Rank-nullity Theorem.

Let us prove that $\sum_{i=1}^n \text{rk}(A_i) = k$ and $\sum_{i=1}^n A_i^* A_i = I$ imply that the A_i 's are partial isometries with the initial spaces E_i forming a partition of \mathbb{C}^k .

For general matrices the spaces E_i are defined as the orthogonal complement of $\ker(A_i)$ in \mathbb{C}^k . Let E be the direct sum of the E_i 's: $E = \bigoplus_{i=1}^n E_i$. Assume $E \subset \mathbb{C}^k$ with a strict inclusion. Then $\exists x \in \mathbb{C}^k$ different from 0 such that $\forall i \in [n], A_i x = 0$. From (4), it follows that

$$\|x\|_2^2 = \sum_{i=1}^n \langle A_i x, A_i x \rangle = 0.$$

That contradicts the condition $x \neq 0$ thus $E = \mathbb{C}^k$.

From (4) again, we have that for every $i \in [n]$, $A_i^* A_i \leq I$, hence $A_i^* A_i \leq P_{E_i}$ since $A_i^* A_i$ is 0 on the orthogonal of E_i . It follows that $\sum_{i=1}^n P_{E_i} \geq I$ by summing over i . Assume this last inequality is strict. From the rank inequality (5), $\sum_{i=1}^n \text{rk}(A_i) > k$ since $\text{rk}(A_i) = \dim(E_i)$ by the Rank-nullity Theorem. Since we assumed that $\sum_{i=1}^n \text{rk}(A_i) = k$ from the contradiction we obtain $\sum_{i=1}^n P_{E_i} = I$. Multiplying on the left and right by a specific P_{E_j} we obtain $\sum_{i \neq j} P_{E_j} P_{E_i} P_{E_j} = 0$.

Since this sum is a sum of positive matrices equal to 0, all the terms must be 0. Hence, the mutual orthogonality of the E_i 's follows.

We proved that the family $\{E_i\}_{i \in [n]}$ is a partition of \mathbb{C}^k . It remains to prove that the A_i 's are partial isometries.

From the mutual orthogonality of the E_i 's and the equality (4), for any $j \in [n]$,

$$A_j \sum_{i=1}^n A_i^* A_i = A_j A_j^* A_j = A_j.$$

Hence the A_i 's are partial isometries. □

We prove next a more specialized version of Cochran's lemma.

Lemma 3.5. *Let $A_1, \dots, A_n \in M_k(\mathbb{C})$ such that*

$$\sum_{i=1}^n A_i^* A_i = I \tag{6}$$

$$\forall i \neq j, \quad A_i^* A_j = 0. \tag{7}$$

Then, the matrices A_i are partial isometries with the family of initial vector spaces $\{E_i\}$ and the family of final vector spaces $\{F_i\}$ forming partitions of \mathbb{C}^k .

Proof. The final vector subspaces F_i are the image of \mathbb{C}^k by the respective A_i : $F_i = A_i \mathbb{C}^k$. The rank of A_i is equal by definition to the dimension of F_i . From the definition of the vector spaces F_i , for any $x \in F_i$ and $y \in F_j$, there exists $x', y' \in \mathbb{C}^k$ such that $x = A_i x'$ and $y = A_j y'$. From (7), if $i \neq j$,

$$\langle x, y \rangle = \langle A_i x', A_j y' \rangle = \langle x', A_i^* A_j y' \rangle = 0.$$

It follows that the F_i 's are mutually orthogonal.

Since the F_i 's are mutually orthogonal, the dimension of the direct sum $F = \bigoplus_{i=1}^n F_i$ is equal to the sum of the dimensions of the F_i 's: $\dim(F) = \sum_{i=1}^n \dim(F_i)$. Since F is a vector subspace of \mathbb{C}^k , $\dim(F) \leq k$. The equality and then the conclusion follow from Lemma 3.4 and (6). □

4. THE DIAGONAL ALGEBRA

We start with the most simple case, that of the diagonal subalgebra

$$D_n := \bigoplus_{a=1}^n M_1(\mathbb{C}).$$

From a physical perspective, this case is probably the most interesting one, and it is also very illuminating from a mathematical point of view. We shall treat separately the cases of CP maps which are unital (the Heisenberg picture) and trace preserving (quantum channels, the Schrödinger picture). Although the results in this section are special cases of the ones in Section 5, we state and prove them separately, in order to showcase the different ideas and techniques involved in the proof, which are more transparent in this case.

4.1. The Heisenberg picture. We are interested physical transformations of observables, that is in unital completely positive maps (UCP). More precisely, such maps can be written as

$$S_{U,\beta}(X) = [\text{id} \otimes \text{Tr}](U^*(X \otimes I_k)U(I_n \otimes \beta)),$$

where $U \in \mathcal{U}_{nk}$ is a unitary operator, $\beta \in M_k^{1,+}(\mathbb{C})$ is a density matrix, and $X \in M_n^{sa}(\mathbb{C})$ is the observable (Hermitian matrix) on which the map acts.

Theorem 4.1. *Let $\{e_i\}_{i=1}^n$ be a fixed basis of \mathbb{C}^n , D_n the commutative algebra of matrices which are diagonal in the basis $\{e_i\}$, and $U \in \mathcal{U}_{nk}$ a bipartite unitary operator. The following statements are equivalent:*

(1) *There exists a set of quantum states \mathcal{B} which spans $M_k(\mathbb{C})$ such that, for any state $\beta \in \mathcal{B}$, the UCP map $S_{U,\beta}$ leaves invariant diagonal matrices:*

$$\forall \beta \in \mathcal{B}, \quad S_{U,\beta}(D_n) \subseteq D_n;$$

(2) *In the basis $\{e_i\}$, the operator U is a matrix of partial isometries (and thus it is of type (C2),(C3)).*

Proof. The easy implication, (2) \implies (1), is proved by direct calculation. By our assumption, the blocks of U are partial isometries, with initial and final spaces satisfying conditions (C2),(C3) from Definition 3.2

$$U = \sum_{i,j=1}^n e_i e_j^* \otimes U_{ij}.$$

For each basis element e_s , we have

$$\begin{aligned} S_{U,\beta}(e_s e_s^*) &= \sum_{i_1, j_1, i_2, j_2=1}^n [\text{id} \otimes \text{Tr}](e_{j_1} e_{i_1}^* \otimes U_{i_1 j_1}^* \cdot e_s e_s^* \otimes I_k \cdot e_{i_2} e_{j_2}^* \otimes U_{i_2 j_2} \cdot I_n \otimes \beta) \\ &= \sum_{j_1, j_2=1}^n e_{j_1} e_{j_2}^* \text{Tr}(U_{s j_1}^* U_{s j_2} \beta). \end{aligned}$$

Since the blocks U_{ij} satisfy condition (C2) from Definition 3.2, the operator $U_{s j_1}^* U_{s j_2}$ is null, unless $j_1 = j_2$. Hence, the output $S_{U,\beta}(e_s e_s^*)$ is a diagonal operator, proving the claim.

Let us now show (1) \implies (2). Going through the computations above, without assuming anything about the blocks of U , we see that the condition that $S_{U,\beta}$ preserves the diagonal implies that for all $s, j_1, j_2 \in [n]$ such that $j_1 \neq j_2$ and for all $\beta \in \mathcal{B}$,

$$\text{Tr}(U_{s j_1}^* U_{s j_2} \beta) = 0.$$

Since \mathcal{B} spans the whole matrix algebra $M_k(\mathbb{C})$, we obtain $U_{s j_1}^* U_{s j_2} = 0$. In turn, this implies $F_{s j_1} \perp F_{s j_2}$ for all $s, j_1, j_2 \in [n]$ such that $j_1 \neq j_2$. Hence $F_s = \bigoplus_j F_{s j}$ is a direct sum of orthogonal subspaces of \mathbb{C}^k . In particular, $\dim F_s = \sum_j \dim F_{s j} \leq k$.

Since U is unitary, we moreover have, for all $s \in [n]$, $\sum_j U_{s j} U_{s j}^* = I_k$. From Cochran's Lemma 3.4 (with $A_j = U_{s j}^*$) we deduce $\dim F_s \geq k$. Hence $\sum_j \text{rk}(U_{s j}) = k$ and the $U_{s j}$'s are partial isometries of type (C2).

Again using the unitarity of U , we get $\sum_i U_{i j}^* U_{i j} = I_k$ for all $j \in [n]$. Since the $U_{i j}$'s are partial isometries, the previous equality reads $\sum_i P_{E_{i j}} = I_k$ for all $j \in [n]$. It follows that, at fixed j , the initial spaces $\{E_{i j}\}_{i \in [n]}$ form a partition of \mathbb{C}^k , which is property (C3) from Definition 3.2. We conclude that the $U_{i j}$'s are partial isometries of type (C2),(C3), proving the claim. \square

Remark 4.2. *Let us consider the simplest case, where $n = k = 2$, and the partial isometries appearing as the blocks of U have unit rank. The 4×4 unitary operators which satisfy the conditions of the result above are of the form*

$$U = \begin{bmatrix} ab^* & a_\perp c^* \\ db_\perp^* & d_\perp c_\perp^* \end{bmatrix} \in M_2(M_2(\mathbb{C})),$$

for some vectors $a, a_\perp, b, b_\perp, c, c_\perp, d, d_\perp \in \mathbb{C}^2$ satisfying the indicated orthogonality relations (we denote by x_\perp a fixed unit vector which is orthogonal to $x \in \mathbb{C}^2$). The UCP map $S_{U,\beta}$ acts as follows on diagonal operators:

$$S_{U,\beta} \left(\begin{bmatrix} x & 0 \\ 0 & y \end{bmatrix} \right) = \begin{bmatrix} x \langle a, \beta a \rangle + y \langle a_\perp, \beta a_\perp \rangle & 0 \\ 0 & x \langle d, \beta d \rangle + y \langle d_\perp, \beta d_\perp \rangle \end{bmatrix}.$$

Example 4.3. *The identity and the flip operator*

$$F_n = \sum_{i,j=1}^n e_i e_j^* \otimes e_j e_i^* \in \mathcal{U}_{n^2}$$

satisfy the conditions in Theorem 4.1, since

$$\begin{aligned} S_{I_{nk},\beta}(X) &= \text{Tr}(\beta)X \\ S_{F_n,\beta}(X) &= \text{Tr}(X\beta)I. \end{aligned}$$

4.2. The Schrödinger picture. Let $D_n \subset M_n(\mathbb{C})$ the set of diagonal $n \times n$ matrices, in some basis $\{e_i\}_{i=1}^n$ of \mathbb{C}^n , which we assume fixed.

The main result of this section is the following theorem, which characterizes unitary matrices preserving, independently of the ancilla state, the diagonal subalgebra of the system space.

Theorem 4.4. *Let $\{e_i\}_{i=1}^n$ be a fixed basis of \mathbb{C}^n , D_n the commutative algebra of matrices which are diagonal in the basis $\{e_i\}$ and $U \in \mathcal{U}_{nk}$ a bipartite unitary operator. The following statements are equivalent:*

- (1) *There exists a set of quantum states \mathcal{B} which spans $M_k(\mathbb{C})$ such that, for any state $\beta \in \mathcal{B}$, the quantum channel $T_{U,\beta}$ leaves invariant diagonal matrices:*

$$\forall \beta \in \mathcal{B}, \quad T_{U,\beta}(D_n) \subseteq D_n;$$

- (2) *In the basis $\{e_i\}$, the operator U is a matrix of partial isometries of type (C2),(C3),(C4).*

When this is the case, for all quantum states $\beta \in M_k^{1,+}(\mathbb{C})$, the quantum channel $T_{U,\beta}$ acts on diagonal matrices as a Markov chain with transition probabilities $(P_{ij})_{i,j \in [n]}$ given by

$$P_{ij} = \text{Tr}(P_{E_{ji}}\beta),$$

where E_{ji} is the initial space of the partial isometry corresponding to the block (j,i) of U .

Proof. The proof follows more or less the same steps as the proof of Theorem 4.1. Let us start with the easier implication (2) \implies (1). Consider a basis element e_s and compute

$$T_{U,\beta}(e_s e_s^*) = \sum_{i,j=1}^n e_i e_j^* \text{Tr}(U_{is} \beta U_{js}^*), \quad (8)$$

where $U_{ij} \in M_k(\mathbb{C})$ are the blocks of U :

$$U = \sum_{i,j=1}^n e_i e_j^* \otimes U_{ij}.$$

Since U is of type (C3), we have $U_{js}^* U_{is} = \delta_{ij} P_{E_{is}}$, and thus

$$T_{U,\beta}(e_s e_s^*) = \sum_{i=1}^n e_i e_i^* \text{Tr}(P_{E_{is}}\beta),$$

proving the claim.

We prove now the second implication, (1) \implies (2). Using equation (8), we obtain that $T_{U,\beta}(e_s e_s^*)$ is a diagonal element iff

$$\forall \beta \in \mathcal{B}, \forall i \neq j \in [n], \quad \text{Tr}(U_{is} \beta U_{js}^*) = 0.$$

Since the above relation holds for a set of matrices β which spans the full matrix algebra, we conclude that

$$\forall s \in [n], \forall i \neq j \in [n], \quad U_{js}^* U_{is} = 0. \quad (9)$$

Using the unitarity condition $U \in \mathcal{U}_{nk}$, we also have

$$\sum_{j=1}^n U_{js}^* U_{js} = I_k.$$

We now apply, for every s , Lemma 3.5 to conclude that all the blocks U_{ij} of U are partial isometries having the property that, for each column, both the initial and the final spaces of the partial isometries form a partition of \mathbb{C}^k (these are the conditions (C3) and (C4) in Definition 3.2). Condition (C2) follows from Lemma 3.3. \square

Remark 4.5. *The condition (C1) from Definition 3.2 is not needed for the result above to hold, as the following example shows. Consider three unit vectors $a, b, c \in \mathbb{C}^2$ with the property that $\langle b, c \rangle \neq 0$, and let*

$$U = \begin{bmatrix} ab^* & a_{\perp}c^* \\ a_{\perp}b_{\perp}^* & ac_{\perp}^* \end{bmatrix} \in M_2(M_2(\mathbb{C})).$$

By direct calculation, one can show that U is a unitary matrix. Notice that U is a matrix of partial isometries satisfying conditions (C2), (C3), (C4) from Definition 3.2, but failing condition (C1). Moreover, for a given qubit density matrix $\beta \in M_2^{1,+}(\mathbb{C})$, the channel $T_{U,\beta}$ acts on diagonal operators as follows:

$$\begin{aligned} T_{U,\beta}(e_1e_1^*) &= \langle b, \beta b \rangle e_1e_1^* + \langle b_{\perp}, \beta b_{\perp} \rangle e_2e_2^* \\ T_{U,\beta}(e_2e_2^*) &= \langle c, \beta c \rangle e_1e_1^* + \langle c_{\perp}, \beta c_{\perp} \rangle e_2e_2^*, \end{aligned}$$

giving rise to the following Markov transition matrix

$$P = \begin{bmatrix} \langle b, \beta b \rangle & \langle b_{\perp}, \beta b_{\perp} \rangle \\ \langle c, \beta c \rangle & \langle c_{\perp}, \beta c_{\perp} \rangle \end{bmatrix}.$$

Note that the matrix above has the general form of a 2×2 stochastic matrix.

If moreover (C1) holds, the matrix P is bistochastic.

5. THE BLOCK-DIAGONAL ALGEBRA

Let

$$\mathcal{A} = \bigoplus_{a=1}^N M_{d_a}(\mathbb{C})$$

be a subalgebra of $M_n(\mathbb{C})$ and

$$\mathbb{C}^n = \bigoplus_{a=1}^N V_a \tag{10}$$

the associated direct sum of orthogonal subspaces decomposition. In the above expression, the integers d_1, \dots, d_N form a partition of n , while the subspaces V_1, \dots, V_N form a partition of \mathbb{C}^n . Our goal is to characterize UCP maps as in (1) (resp. TPCP as in (2)) which leave the algebra \mathcal{A} invariant, irrespective of the ancilla state β . Let us consider a basis $\{e_1, \dots, e_n\}$ of \mathbb{C}^n which is compatible with the decomposition (10), that is there exists a partition $[n] = \sqcup_{a=1}^N \mathbf{a}$ such that $V_a = \text{linspan}\{e_i\}_{i \in \mathbf{a}}$ for all $a \in [N]$. We define an equivalence relation $i \sim j \Leftrightarrow i, j \in \mathbf{a}$ for a unique $a \in [N]$.

We shall consider two different block decompositions of the unitary interaction matrix $U \in \mathcal{U}_{nk}$: the usual one

$$U = \sum_{i,j=1}^n e_i e_j^* \otimes \tilde{U}_{ij},$$

with $\tilde{U}_{ij} \in M_k(\mathbb{C})$, and the decomposition corresponding to the coarser partition (10)

$$U = \begin{bmatrix} U_{11} & U_{12} & \cdots & U_{1N} \\ U_{21} & U_{22} & \cdots & U_{2N} \\ \vdots & & \ddots & \vdots \\ U_{N1} & \cdots & \cdots & U_{NN} \end{bmatrix},$$

where

$$U_{ab} = \sum_{\substack{i \in \mathbf{a} \\ j \in \mathbf{b}}} e_i e_j^* \otimes \tilde{U}_{ij} \in M_{d_a k \times d_b k}(\mathbb{C}).$$

Accordingly, let $\{E_{ab}\}_{a,b \in [N]}$ (resp. $\{F_{ab}\}_{a,b \in [N]}$) be the initial (resp. final) spaces of the matrices U_{ab} : $E_{ab} = (\ker U_{ab})^\perp$ and $F_{ab} = \text{ran } U_{ab}$.

5.1. The Heisenberg picture. As before, we start with the Heisenberg picture of UCP maps, since the statement and the proof of the main result are easier. Note that the Theorem below generalizes Theorem 4.1, which corresponds to the particular case $d_a = 1$ for all $a \in [N]$.

Theorem 5.1. *Let $U \in \mathcal{U}_{nk}$ and \mathcal{A} the above defined subalgebra of $M_n(\mathbb{C})$. The following two statements are equivalent:*

- (1) *There exists a set of quantum states \mathcal{B} which spans $M_k(\mathbb{C})$ such that for any $\beta \in \mathcal{B}$, the subalgebra \mathcal{A} is stable by the UCP map $S_{\beta,U}$:*

$$\forall \beta \in \mathcal{B}, \quad S_{U,\beta}(\mathcal{A}) \subset \mathcal{A}.$$

- (2) *The matrices $\{U_{ab}\}_{a,b \in [N]}$ are partial isometries from $V_b \otimes \mathbb{C}^k$ to $V_a \otimes \mathbb{C}^k$ such that*
- (a) *For any $a, b \in [N]$, $F_{ab} = V_a \otimes \hat{F}_{ab}$ and for each $a \in [N]$, the family $\{\hat{F}_{ab}\}_{b \in [N]}$ is a partition of \mathbb{C}^k ;*
 - (b) *For each $b \in [N]$, the family $\{E_{ab}\}_{a \in [N]}$ is a partition of $V_b \otimes \mathbb{C}^k$.*

Proof. Let us show (1) \implies (2). We initially follow the same path as for Theorem 4.1. By direct computation, it is easy to see that the hypothesis from (1) is equivalent to

$$\forall i \sim j \text{ and } x \not\sim y, \quad \tilde{U}_{ix}^* \tilde{U}_{jy} = 0. \quad (11)$$

It remains to prove the equivalence of (2) with this statement.

We can reformulate (11) in terms of matrices:

$$\forall a, b, c \in [N], b \neq c, \forall X \in M_{d_a}(\mathbb{C}), \quad U_{ab}^*(X \otimes I_k)U_{ac} = 0. \quad (12)$$

The proof of this equivalence amounts to taking specific matrices $X = e_i e_j^*$ and multiplying on the left and right by $e_x e_x^* \otimes I_k$ and $e_y e_y^* \otimes I_k$ respectively. We leave the details to the reader.

Let us prove that (12) implies

- (1) For all $a \in [N]$, the family $\{F_{ab}\}_{b \in [N]}$ is a partition of $V_a \otimes \mathbb{C}^k$;
- (2) For all $b \in [N]$, the family $\{E_{ab}\}_{a \in [N]}$ is a partition of $V_b \otimes \mathbb{C}^k$.

On the one hand, taking $X = I_{d_a}$ in (12), we deduce that for each $a \in [N]$ and $b \neq c$, $F_{ab} \perp F_{ac}$. It follows that $F_a = \bigoplus_b F_{ab}$ is a subspace of $V_a \otimes \mathbb{C}^k$ and is a direct sum of orthogonal subspaces thus $\dim F_a = \sum_{b \in [N]} \dim F_{ab} \leq d_a k$.

On the other hand, since U is unitary, $\sum_b U_{ab} U_{ab}^* = I_{d_a k}$. Hence from Cochran's Lemma 3.4, $\sum_b \dim F_{ab} \geq d_a k$. Thus $\sum_b \dim F_{ab} = d_a k$ and the matrices U_{ab} are partial isometries with $\{F_{ab}\}_b$ a partition of $V_a \otimes \mathbb{C}^k$. Again, since U is unitary $\sum_a U_{ab}^* U_{ab} = \sum_a P_{E_{ab}} = I_{d_b k}$. Hence $\{E_{ab}\}_{a \in [N]}$ is a partition of $V_b \otimes \mathbb{C}^k$.

We now show that (12) implies a finer structure for the final spaces.

Let $a, b, c \in [N]$ such that $b \neq c$. Let $\phi \in F_{ab}$ and $\psi \in F_{ac}$. Assuming (12), we have that for all $X \in M_{d_a}(\mathbb{C})$, $\langle \phi, (X \otimes I_k)\psi \rangle = 0$. Let the families $\{\phi_i\}_{i \in \mathbf{a}} \subset \mathbb{C}^k$ and $\{\psi_i\}_{i \in \mathbf{a}} \subset \mathbb{C}^k$ be such that $\phi = \sum_{i \in \mathbf{a}} e_i \otimes \phi_i$ and $\psi = \sum_{i \in \mathbf{a}} e_i \otimes \psi_i$. Set $X \in M_{d_a}(\mathbb{C})$ such that in the basis $\{e_i\}_{i \in \mathbf{a}}$,

$$X_{ij} = \begin{cases} \frac{|\langle \phi_i, \psi_j \rangle|}{\langle \phi_i, \psi_j \rangle} & \text{if } \langle \phi_i, \psi_j \rangle \neq 0 \\ 1 & \text{if } \langle \phi_i, \psi_j \rangle = 0 \end{cases}$$

Then $\langle \phi, (X \otimes I_k)\psi \rangle = 0$ implies

$$\sum_{i, j \in \mathbf{a}} |\langle \phi_i, \psi_j \rangle| = 0.$$

Hence for all $i, j \in \mathbf{a}$, $\phi_i \perp \psi_j$.

Let $\hat{F}_{ab} = \text{linspan}\{\phi_i | \phi \in F_{ab}, \phi = \sum_{i \in \mathbf{a}} e_i \otimes \phi_i\}$ and $\hat{F}_{ac} = \text{linspan}\{\psi_i | \psi \in F_{ac}, \psi = \sum_{i \in \mathbf{a}} e_i \otimes \psi_i\}$. We have $\hat{F}_{ab} \perp \hat{F}_{ac}$ and $F_{ab} \subset V_a \otimes \hat{F}_{ab}$ for all $b \in [N]$. We shall prove the converse inclusion.

Let $x \in V_a$ and $\phi \in \hat{F}_{ab}$. Then $x \otimes \phi \in V_a \otimes \hat{F}_{ab}$ hence $\forall \psi \in F_{ac}$, $\langle x \otimes \phi, \psi \rangle = 0$ for any $c \neq b$. Since $\{F_{ab}\}_{b \in [N]}$ is a partition of $V_a \otimes \mathbb{C}^k$, $x \otimes \phi \in F_{ab}$. Hence $V_a \otimes \hat{F}_{ab} \subset F_{ab}$ and $F_{ab} = V_a \otimes \hat{F}_{ab}$. Since $\{F_{ab}\}_{b \in [N]}$ is a partition of $V_a \otimes \mathbb{C}^k$, $\{\hat{F}_{ab}\}_{b \in [N]}$ is a partition of \mathbb{C}^k .

For the converse implication (2) \implies (1), assume (a) and let us prove (12). Let $(\phi, \psi) \in V_c \otimes \mathbb{C}^k \times V_b \otimes \mathbb{C}^k$, for some blocks $b \neq c$. Then $U_{ab}\psi \in V_a \otimes \hat{F}_{ab}$ and $U_{ac}\phi \in V_a \otimes \hat{F}_{ac}$. Then for any $X \in M_{d_a}(\mathbb{C})$,

$$\begin{aligned} \langle \psi, U_{ab}^*(X \otimes I_k)U_{ac}\phi \rangle &= \langle U_{ab}\psi, (I_{d_a} \otimes P_{\hat{F}_{ab}})(X \otimes I_k)(I_{d_a} \otimes P_{\hat{F}_{ac}})U_{ac}\phi \rangle \\ &= \langle U_{ab}\psi, (X \otimes P_{\hat{F}_{ab}}P_{\hat{F}_{ac}})U_{ac}\phi \rangle \\ &= 0. \end{aligned}$$

We deduce (12) and thus (1). \square

At the level of examples, the identity and the flip operators from Example 4.3 satisfy also the conditions in Theorem 5.1.

5.2. The Schrödinger picture. We move now to the Schrödinger case. Since the proof follows closely what has been done in the previous sections, we only sketch the main ideas, leaving the details to the reader.

Theorem 5.2. *Let $U \in \mathcal{U}_{nk}$ and \mathcal{A} the above defined subalgebra of $M_n(\mathbb{C})$. The following two statements are equivalent:*

- (1) *There exists a set of quantum states \mathcal{B} which spans $M_k(\mathbb{C})$ such that for any $\beta \in \mathcal{B}$, the subalgebra \mathcal{A} is stable by the quantum channel $T_{\beta, U}$:*

$$\forall \beta \in \mathcal{B}, \quad T_{U, \beta}(\mathcal{A}) \subset \mathcal{A}.$$

- (2) *The matrices $\{U_{ab}\}_{a, b \in [N]}$ are partial isometries from $V_b \otimes \mathbb{C}^k$ to $V_a \otimes \mathbb{C}^k$ such that,*

- (a) *For any $a, b \in [N]$, $F_{ab} = V_a \otimes \hat{F}_{ab}$ and for each $a \in [N]$, the family $\{\hat{F}_{ab}\}_{b \in [N]}$ is a partition of \mathbb{C}^k ;*
 (b) *For each $b \in [N]$, the family $\{F_{ab}\}_{a \in [N]}$ is a partition of $V_b \otimes \mathbb{C}^k$;*
 (c) *For each $b \in [N]$, the family $\{E_{ab}\}_{a \in [N]}$ is a partition of $V_b \otimes \mathbb{C}^k$.*

Proof. From direct computation, (1) is equivalent to

$$\forall i \sim j \text{ and } x \approx y, \quad \tilde{U}_{yj}^* \tilde{U}_{xi} = 0. \quad (13)$$

The implication (2) \implies (1) proof is then identical to the one of Theorem 5.1. We thus only show the implication, (1) \implies (2).

In terms of matrices, (13) is equivalent to,

$$\forall a, b, c \in [N], b \neq c, \forall X \in M_{d_b \times d_c}, \quad U_{ba}^*(X \otimes I_k)U_{ca} = 0. \quad (14)$$

Let us prove that,

- (1) For each $a \in [N]$, the family $\{F_{ab}\}_{b \in [N]}$ is a partition of $V_a \otimes \mathbb{C}^k$;
- (2) For each $b \in [N]$, the family $\{F_{ab}\}_{a \in [N]}$ is a partition of $V_b \otimes \mathbb{C}^k$;
- (3) For each $b \in [N]$, the family $\{E_{ab}\}_{a \in [N]}$ is a partition of $V_b \otimes \mathbb{C}^k$.

Fix $a, b, c \in [N]$, $b \neq c$ such that $d_b \geq d_c$. Let,

$$X = U \begin{pmatrix} I_{d_c} \\ 0 \end{pmatrix}$$

with U a unitary $d_b \times d_b$ matrix. Spanning over all possible U , equation (14) implies $F_{ba} \perp F_{ca}$. It follows that for every $a \in [N]$, $\sum_{b \in [N]} \text{rk}(U_{ba}) \leq d_a k$. Since $\sum_{b \in [N]} U_{ba}^* U_{ba} = I_{d_a} \otimes I_k$, from Cochran Lemma 3.4, $\sum_{b \in [N]} \text{rk}(U_{ba}) \geq k$ and for any $a, b \in [N]$, U_{ab} is a partial isometry such that for any $a \in [N]$ the family $\{F_{ba}\}_{b \in [N]}$ is a partition of $V_a \otimes \mathbb{C}^k$ and (1) holds.

Since for any $b \in [N]$, $\sum_{a \in [N]} U_{ba} U_{ba}^* = I_{d_b} \otimes I_k$ and for any $a \in [N]$, $\sum_{b \in [N]} U_{ba}^* U_{ba} = I_{d_a} \otimes I_k$, the fact that the matrices U_{ab} are partial isometries implies (2) and (3) hold.

We now show that (14) implies a finer structure for the final spaces.

Let $a, b, c \in [N]$ such that $b \neq c$. Let $\phi \in F_{ba}$ and $\psi \in F_{ca}$. Assuming (14), we have that for all $X \in M_{d_b \times d_c}(\mathbb{C})$, $\langle \phi, (X \otimes I_k)\psi \rangle = 0$. Let the families $\{\phi_i\}_{i \in \mathbf{b}} \subset \mathbb{C}^k$ and $\{\psi_i\}_{i \in \mathbf{c}} \subset \mathbb{C}^k$ be such that $\phi = \sum_{i \in \mathbf{b}} e_i \otimes \phi_i$ and $\psi = \sum_{i \in \mathbf{c}} e_i \otimes \psi_i$. Set $X \in M_{d_b \times d_c}(\mathbb{C})$ such that in the orthonormal bases $\{e_i\}_{i \in \mathbf{b}}$ and $\{e_j\}_{j \in \mathbf{c}}$ of respectively V_b and V_c ,

$$X_{ij} = \begin{cases} \frac{|\langle \phi_i, \psi_j \rangle|}{\langle \phi_i, \psi_j \rangle} & \text{if } \langle \phi_i, \psi_j \rangle \neq 0 \\ 1 & \text{if } \langle \phi_i, \psi_j \rangle = 0 \end{cases}$$

Then $\langle \phi, (X \otimes I_k)\psi \rangle = 0$ implies

$$\sum_{(i,j) \in \mathbf{b} \times \mathbf{c}} |\langle \phi_i, \psi_j \rangle| = 0.$$

Hence for all $(i, j) \in \mathbf{b} \times \mathbf{c}$, $\phi_i \perp \psi_j$.

Let $\hat{F}_{ba} = \text{linspan}\{\phi_i | \phi \in F_{ba}, \phi = \sum_{i \in \mathbf{b}} e_i \otimes \phi_i\}$ and $\hat{F}_{ca} = \text{linspan}\{\psi_i | \psi \in F_{ca}, \psi = \sum_{i \in \mathbf{c}} e_i \otimes \psi_i\}$. We have $\hat{F}_{ba} \perp \hat{F}_{ca}$ and $F_{ba} \subset V_b \otimes \hat{F}_{ba}$ for all $b \in [N]$. We shall prove the converse inclusion.

Let $x \in V_b$ and $\phi \in \hat{F}_{ba}$. Then $x \otimes \phi \in V_b \otimes \hat{F}_{ba}$ hence $\forall \psi \in F_{ca}$, $\langle x \otimes \phi, \psi \rangle = 0$ for any $c \neq b$. Since $\{F_{ba}\}_{b \in [N]}$ is a partition of $V_a \otimes \mathbb{C}^k$, $x \otimes \phi \in F_{ba}$. Hence $V_b \otimes \hat{F}_{ba} \subset F_{ba}$ and $F_{ba} = V_b \otimes \hat{F}_{ba}$. Since $\{F_{ba}\}_{a \in [N]}$ is a partition of $V_b \otimes \mathbb{C}^k$, $\{\hat{F}_{ba}\}_{a \in [N]}$ is a partition of \mathbb{C}^k . \square

5.3. Comparing subalgebras. In this section, we would like to investigate the relation between the sets

$$\mathcal{U}_i^{(\text{inv})} = \{U \in \mathcal{U}_{nk} : S_{U,\beta}(\mathcal{A}_i) \subseteq \mathcal{A}_i\},$$

for the subalgebras $\mathcal{A}_{1,2} \subseteq M_n(\mathbb{C})$ with the property that $\mathcal{A}_1 \subseteq \mathcal{A}_2$, focusing on the Heisenberg picture. Note that the two trivial extremal cases, $\mathcal{A} = \mathbb{C}I$ and $\mathcal{A} = M_n(\mathbb{C})$ lead both to the set of all unitary operators. In a situation where both algebras are non-trivial, we claim that the two sets of unitary operators leaving them invariant are not comparable. We shall consider the simplest example, and leave the extension to the general case to the reader.

Let $n = 3$ and consider

$$\begin{aligned} \mathcal{A}_1 &= M_1(\mathbb{C}) \oplus M_1(\mathbb{C}) \oplus M_1(\mathbb{C}) \subset M_3(\mathbb{C}) \\ \mathcal{A}_2 &= M_2(\mathbb{C}) \oplus M_1(\mathbb{C}) \subset M_3(\mathbb{C}) \end{aligned}$$

To show that $\mathcal{U}_1^{(\text{inv})} \not\subseteq \mathcal{U}_2^{(\text{inv})}$, consider the following operator

$$U = \begin{bmatrix} e_1 e_1^* & e_2 e_1^* & e_3 e_1^* \\ e_3 e_2^* & e_1 e_2^* & e_2 e_2^* \\ e_2 e_3^* & e_3 e_3^* & e_1 e_3^* \end{bmatrix}.$$

Obviously, the operator U above satisfies the conditions (C2), (C3) from Definition 3.2, so $U \in \mathcal{U}_1^{(\text{inv})}$. However, for the equivalence relation $1 \sim 2 \approx 3$ induced by the subalgebra \mathcal{A}_2 , and the choice of indices $(i, j, x, y) = (1, 2, 2, 3)$, equation (11) from the proof of Theorem 5.1 is not satisfied:

$$\tilde{U}_{ix}^* \tilde{U}_{jy} = (e_2 e_1^*)^* e_2 e_2^* = e_1 e_2^* \neq 0,$$

hence $U \notin \mathcal{U}_2^{(\text{inv})}$.

To show that the reversed inclusion also fails to hold, consider a unitary matrix $W \in \mathcal{U}_4$ partitioned in 2×2 blocks W_{ij} :

$$W = \begin{bmatrix} W_{11} & W_{12} \\ W_{21} & W_{22} \end{bmatrix}.$$

We construct the following unitary matrix $U \in \mathcal{U}_9$:

$$U = \begin{bmatrix} 0 & 0 & 0 & 0 & 0 & 0 & 0 & 1 & 0 \\ 0 & & W_{11} & & 0 & & W_{12} & & 0 & 0 & 0 \\ 0 & & & 0 & & & & 0 & 0 & 0 & 0 \\ 0 & 0 & 0 & 0 & 0 & 0 & 0 & 0 & 0 & 0 & 1 \\ 0 & & W_{21} & & 0 & & W_{22} & & 0 & 0 & 0 \\ 0 & & & 0 & & & & 0 & 0 & 0 & 0 \\ 0 & 0 & 0 & 0 & 0 & 0 & 0 & 1 & 0 & 0 & 0 \\ 1 & 0 & 0 & 0 & 0 & 0 & 0 & 0 & 0 & 0 & 0 \\ 0 & 0 & 0 & 1 & 0 & 0 & 0 & 0 & 0 & 0 & 0 \end{bmatrix}.$$

One can check by direct computation that $U \in \mathcal{U}_2^{(\text{inv})}$. However if one chooses W in such a way that one of the blocks W_{ij} is *not* a partial isometry, then $U \notin \mathcal{U}_1^{(\text{inv})}$. This is always possible, since one can simply choose any small enough matrix $W_{11} \in M_2(\mathbb{C})$ and complete it to a full unitary matrix $W \in \mathcal{U}_4$.

6. THE TENSOR PRODUCT ALGEBRA

We now analyze the case where there is just one term in the direct sum in (3), that is

$$\mathcal{A} = M_d(\mathbb{C}) \otimes I_r.$$

In particular, the system Hilbert space decomposes as $\mathbb{C}^n = \mathbb{C}^d \otimes \mathbb{C}^r$, with $n = dr$. We shall denote by $\omega_k \in \mathbb{C}^k \otimes \mathbb{C}^k$ the (un-normalized) *maximally entangled state*

$$\omega_k = \sum_{i=1}^k e_i \otimes e_i, \tag{15}$$

for some fixed orthonormal basis $\{e_1, \dots, e_k\}$ of \mathbb{C}^k .

6.1. The Heisenberg picture.

Theorem 6.1. *Let $U \in \mathcal{U}_{nk}$ be a bipartite unitary operator. The following are equivalent:*

- (1) *There exists a set of quantum states \mathcal{B} which spans $M_k(\mathbb{C})$ such that for any $\beta \in \mathcal{B}$, the subalgebra \mathcal{A} is stable by the UCP map $S_{\beta,U}$:*

$$\forall \beta \in \mathcal{B}, \quad S_{U,\beta}(\mathcal{A}) \subset \mathcal{A}.$$

- (2) *There exist unitary operators $V \in \mathcal{U}_{rk}$ and $W \in \mathcal{U}_{dk}$ such that*

$$U = (I_d \otimes V) \cdot (W \otimes I_r). \quad (16)$$

Proof. We first show (2) \implies (1). For an interaction unitary operator U as in (16), we have

$$\begin{aligned} S_{U,\beta}(X \otimes I_r) &= (\text{id}_d \otimes \text{id}_r \otimes \text{Tr}_k) [(W^* \otimes I_r)(I_d \otimes V^*)(X \otimes I_r \otimes I_k)(I_d \otimes V)(W \otimes I_r)(I_{dr} \otimes \beta)] \\ &= (\text{id}_d \otimes \text{id}_r \otimes \text{Tr}_k) [(W^* \otimes I_r)(X \otimes I_r \otimes I_k)(W \otimes I_r)(I_{dr} \otimes \beta)] \\ &= (\text{id}_d \otimes \text{Tr}_k) [W^*(X \otimes I_k)W(I_d \otimes \beta)] \otimes I_r \\ &= S_{W,\beta}(X) \otimes I_r \in \mathcal{A}, \end{aligned}$$

proving the claim; a graphical representation of the computation above can be found in Figure 1.

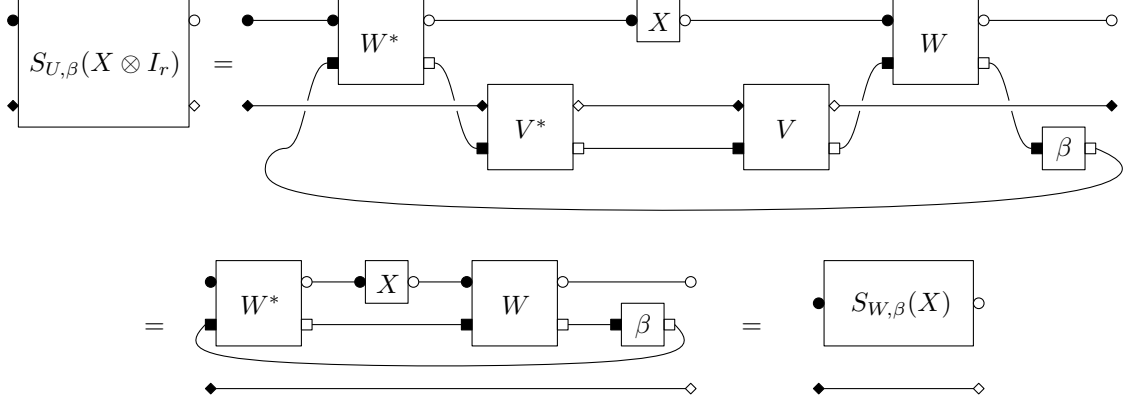

FIGURE 1. Bipartite unitary operators as in (16) yield \mathcal{A} -preserving UCP maps. Round, diamond, and respectively square decorations correspond to the Hilbert spaces \mathbb{C}^d , \mathbb{C}^r , and respectively \mathbb{C}^k .

For the reverse implication, using linearity and the hypothesis, we find that there is a bi-linear function $f_U(X, \beta)$ such that

$$\forall X \in M_n(\mathbb{C}), \beta \in M_k(\mathbb{C}), \quad S_{U,\beta}(X \otimes I_r) = f_U(X, \beta) \otimes I_r.$$

We rewrite the last equation as

$$(\text{id}_d \otimes \text{id}_r \otimes \text{Tr}_k) \left[(U^\Gamma)^*(X \otimes I_r \otimes \beta^\top) U^\Gamma \right] = f_U(X, \beta) \otimes I_r,$$

where U^Γ is the partial transpose of the unitary operator U with respect to the \mathbb{C}^k tensor factor: $U^\Gamma = (\text{id}_d \otimes \text{id}_r \otimes \text{transp}_k)(U)$. From the universal property of the tensor product $M_n(\mathbb{C}) \otimes M_k(\mathbb{C})$, we find that there exists a linear function $g_U : M_{dk}(\mathbb{C}) \rightarrow M_d(\mathbb{C})$ such that

$$(\text{id}_d \otimes \text{id}_r \otimes \text{Tr}_k) \left[(U^\Gamma)^*(X \otimes I_r \otimes \beta^\top) U^\Gamma \right] = g_U(X \otimes \beta^\top) \otimes I_r.$$

Moreover, since the left hand side above is a completely positive function of the input $X \otimes \beta^\top$, the same must hold for g_U . Hence, from the Kraus form of CP maps, we can find, for some $s \geq 1$, a linear operator $A : \mathbb{C}^{ds} \rightarrow \mathbb{C}^{dk}$ such that $g_U(X \otimes \beta) = (\text{id}_d \otimes \text{Tr}_s) [A^*(X \otimes \beta)A]$; note that we have

dropped the transposition operation on β , using the fact that a family \mathcal{B} spans $M_k(\mathbb{C})$ iff \mathcal{B}^Γ does. We have thus, for all X and β ,

$$(\text{id}_d \otimes \text{id}_r \otimes \text{Tr}_k) [(U^\Gamma)^*(X \otimes I_r \otimes \beta)U^\Gamma] = (\text{id}_d \otimes \text{id}_r \otimes \text{Tr}_s) [A^*(X \otimes I_r \otimes \beta)A],$$

where we recognize two different dilations of a CP map. On the level of the Choi matrices, the equality above translates to

$$\begin{aligned} & (\text{id}_d \otimes \text{id}_d \otimes \text{id}_r \otimes \text{Tr}_k \otimes \text{id}_k) [(I_d \otimes (U^\Gamma)^* \otimes I_k)(\omega_d \omega_d^* \otimes I_r \otimes \omega_k \omega_k^*)(I_d \otimes U^\Gamma \otimes I_k)] = \\ & (\text{id}_d \otimes \text{id}_d \otimes \text{Tr}_s \otimes \text{id}_k) [(I_d \otimes A^* \otimes I_k)(\omega_d \omega_d^* \otimes \omega_k \omega_k^*)(I_d \otimes A \otimes I_k)] \otimes I_r \iff \\ & (I_d \otimes U^*)(\omega_d \omega_d^* \otimes I_r \otimes I_k)(I_d \otimes U) = [(I_d \otimes (A^\Gamma)^*)(\omega_d \omega_d^* \otimes I_s)(I_d \otimes A^\Gamma)] \otimes I_r, \end{aligned}$$

where $A^\Gamma : \mathbb{C}^d \otimes \mathbb{C}^k \rightarrow \mathbb{C}^d \otimes \mathbb{C}^s$ is the partial transposition of the operator A with respect to the second subsystems. The two square roots of the last equation above are related by a partial isometry $V : \mathbb{C}^{rs} \rightarrow \mathbb{C}^{rk}$ as follows

$$(\omega_d^* \otimes I_r \otimes I_k)(I_d \otimes U) = (I_d \otimes I_d \otimes V) [(\omega_d \otimes I_s)(I_d \otimes A^\Gamma) \otimes I_r] \iff U = (I_d \otimes V)(A^\Gamma \otimes I_r).$$

Let us set $W := A^\Gamma$. Since U is an unitary operator, we have

$$I_{drk} = U^*U = (W^* \otimes I_r)(I_d \otimes V^*)(I_d \otimes V)(W \otimes I_r).$$

and thus V^*V must have full rank, i.e. V is an isometry; in particular, $s \leq k$. But then, $I_{drk} = W^*W \otimes I_r$, hence W is also an isometry, implying $k \leq s$. We have thus $s = k$, and V, W are unitary operators, as claimed. \square

Let us consider some special cases of the result above. In the $d = 1$ or $r = 1$ case, requiring that the algebra \mathcal{A} should be preserved does not impose additional constraints, so we recover the set of all unitary matrices \mathcal{U}_{nk} . If $k = 1$, the ancilla space is trivial, and the UCP map acts by unitary conjugation. It is clear then that the unitary operator U must be a tensor product, $U = W \otimes V$, with $W \in \mathcal{U}_d$ and $V \in \mathcal{U}_r$.

6.2. The Schrödinger picture. Before stating our main result, we introduce the set of bipartite unitary operators with the property that their partial transpose is also unitary

$$\mathcal{U}_{\text{unital}} := \{U \in \mathcal{U}_{nk} : U^\Gamma \in \mathcal{U}_{nk}\} = \mathcal{U}_{nk} \cap \mathcal{U}_{nk}^\Gamma. \quad (17)$$

This set has been studied in [11], and we refer the reader to that paper for additional properties of such unitary operators.

Theorem 6.2. *Let $U \in \mathcal{U}_{nk}$ be a bipartite unitary operator. The following are equivalent:*

- (1) *There exists a set of quantum states \mathcal{B} which spans $M_k(\mathbb{C})$ such that for any $\beta \in \mathcal{B}$, the subalgebra \mathcal{A} is stable by the quantum channel $T_{\beta,U}$:*

$$\forall \beta \in \mathcal{B}, \quad T_{U,\beta}(\mathcal{A}) \subset \mathcal{A}.$$

- (2) *There exist unitary operators $V \in \mathcal{U}_{dk}$ and $W \in \mathcal{U}_{rk} \cap \mathcal{U}_{rk}^\Gamma$ such that*

$$U = (I_d \otimes W^\Gamma) \cdot (V \otimes I_r). \quad (18)$$

Proof. Let us first show (2) \implies (1). Consider a bipartite unitary U as in (18); for any $A \in M_d(\mathbb{C})$ and $\beta \in M_k(\mathbb{C})$, we have

$$\begin{aligned} T_{U,\beta}(A \otimes I_r) &= (\text{id}_d \otimes \text{id}_r \otimes \text{Tr}_k) [(I_d \otimes W)(V \otimes I_r)(A \otimes I_r \otimes \beta)(V^* \otimes I_r)(I_d \otimes W^*)] \\ &= (I_d \otimes I_r \otimes \omega_k^*)(V \otimes W^\Gamma)(A \otimes \beta \otimes I_r \otimes I_r)(V^* \otimes W^{\Gamma*})(I_d \otimes I_r \otimes \omega_k) \\ &= (\text{id}_d \otimes \text{Tr}_k) [V(A \otimes \beta)V^*] \otimes I_r \in \mathcal{A}, \end{aligned}$$

where ω is the maximally entangled state (15). The computation above is represented graphically in Figure 2.

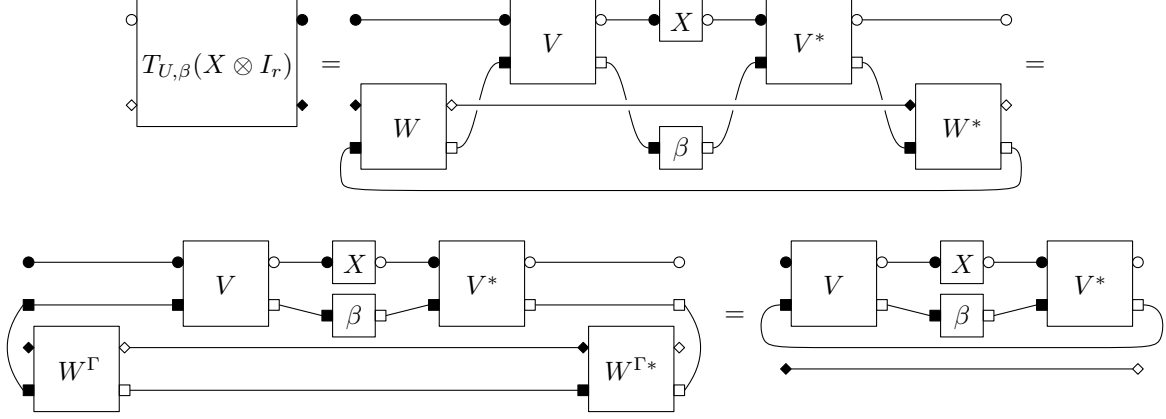

FIGURE 2. Bipartite unitary operators as in (18) yield \mathcal{A} -preserving channels.

Let us now prove (1) \implies (2). We follow the steps in the proof of Theorem 6.1. Using linearity, the universal property of the tensor product and complete positivity, we find that there are operators $V : \mathbb{C}^{dk} \rightarrow \mathbb{C}^{ds}$ and $W : \mathbb{C}^{kr} \rightarrow \mathbb{C}^{sr}$, for some $s \geq 1$, such that

$$\omega_k^* U = \omega_s(V \otimes W),$$

see Figure 3, left panel. Moreover, the application W^* is an isometry, so $s \leq k$. Denoting by W^Γ the partial transposition of W with respect to the spaces \mathbb{C}^k and \mathbb{C}^s , that is

$$W^\Gamma = \sum_{a,b=1}^r \sum_{i=1}^k \sum_{j=1}^s \langle e_i \otimes e_a, W e_j \otimes e_b \rangle e_j \otimes e_a \cdot e_i^* \otimes e_b^*,$$

we have

$$U = (I_d \otimes W^\Gamma)(V \otimes I_r),$$

as claimed; see Figure 3, right panel. From the trace preservation condition, we get that V is an isometry, and thus $k \leq s$. We conclude that $k = s$, and thus both V and W are unitary operators. Asking that $UU^* = I_{dkr}$ yields G^Γ unitary, proving the final claim and finishing the proof.

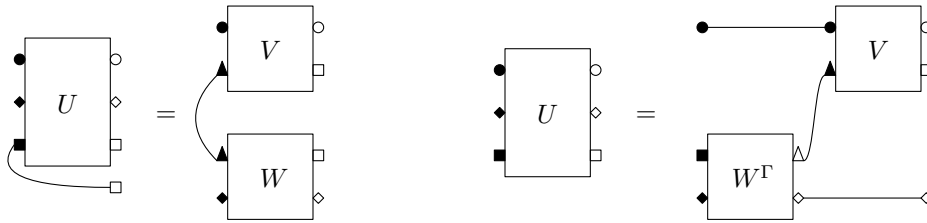

FIGURE 3. The relation between the operators U, V, W . Triangle shaped labels correspond to the space \mathbb{C}^s ; in the proof, it is shown that $s = k$.

□

As in the Heisenberg case, we discuss next some special cases of Theorem 6.2. In the case where $r = 1$, \mathcal{A} is the full input matrix algebra, so we recover the set of all unitary matrices \mathcal{U}_{rk} . If $k = 1$, the ancilla space is trivial, and the quantum channel acts by unitary conjugation; hence, U must be a tensor product, $U = V \otimes W$, with $V \in \mathcal{U}_d$ and $W \in \mathcal{U}_r$. Finally, if $d = 1$, we just require of the quantum channels $T_{U,\beta}$ to be unital, independently of the value of β ; but this is precisely Theorem [11, Theorem 3.1]: the unitary operator U must be such that its partial transpose is also unitary $U = W \in \mathcal{U}_{rk} \cap \mathcal{U}_{rk}^\Gamma$.

6.3. Comparing subalgebras. We would like to address here the same question as the one in Section 5.3, but with the following choice of subalgebras:

$$\begin{aligned}\mathcal{A}_1 &= M_d(\mathbb{C}) \otimes I_r \\ \mathcal{A}_2 &= \underbrace{M_d(\mathbb{C}) \oplus M_d(\mathbb{C}) \oplus \cdots \oplus M_d(\mathbb{C})}_{r \text{ times}},\end{aligned}$$

where $d, r \geq 2$ are two arbitrary integers, and $n = dr$. It is clear that $\mathcal{A}_1 \subseteq \mathcal{A}_2$. As in the previous case, we show that the two sets of unitary operators that leave invariant the above subalgebras cannot be compared.

Let us start by considering a general element from $\mathcal{U}_1^{(\text{inv})}$, of the form $U = (I_d \otimes V)(W \otimes I_r)$, see Theorem 6.1. In order to check the conditions in Theorem 5.1, we decompose

$$V = \sum_{a,b=1}^r V_{ab} \otimes e_a e_b^*,$$

and obtain the following expression for the blocks of U :

$$U_{ab} = (I_d \otimes V_{ab})W \in M_{dk}(\mathbb{C}).$$

Since W is unitary, an operator as above is a partial isometry iff V_{ab} is one; but one can easily construct a unitary matrix V having at least one block which is not a partial isometry (one can pick any small enough matrix V_{11} which is not a partial isometry and extend it to a unitary matrix). This shows that $\mathcal{U}_1^{(\text{inv})} \not\subseteq \mathcal{U}_2^{(\text{inv})}$.

To show that the reversed inclusion also fails to hold, consider the case $k = r$ and choose two families $\{e_{ab}\}, \{f_{ab}\}$ of k^2 vectors, such that the conditions corresponding to conditions (C2), (C3) of Definition 3.2 are satisfied:

$$\begin{aligned}\forall b, \{e_{ab}\}_a &\text{ is an orthonormal basis of } \mathbb{C}^k \\ \forall a, \{f_{ab}\}_b &\text{ is an orthonormal basis of } \mathbb{C}^k.\end{aligned}$$

Define

$$U := \sum_{a,b=1}^{r=k} g_a g_b^* \otimes \tilde{V}_{ab} \otimes f_{ab} e_{ab}^*,$$

where $\{g_a\}$ is another orthonormal basis of $\mathbb{C}^r = \mathbb{C}^k$ and $\{\tilde{V}_{ab}\}$ is an arbitrary family of unitary operators acting on \mathbb{C}^d . The operator defined above leaves invariant the algebra \mathcal{A}_2 , since its blocks

$$U_{ab} = \tilde{V}_{ab} \otimes f_{ab} e_{ab}^*$$

are partial isometries satisfying the hypotheses of Theorem 5.1 with initial and final spaces given by

$$E_{ab} = \mathbb{C}^d \otimes \mathbb{C} e_{ab} \quad \text{and} \quad F_{ab} = \mathbb{C}^d \otimes \mathbb{C} f_{ab}.$$

Let us assume now that the unitary U described above also leaves the algebra \mathcal{A}_2 invariant; from Theorem 6.1, we find unitary operators $V \in \mathcal{U}_{k^2}$ and $W \in \mathcal{U}_{kd}$ such that $U = (I_d \otimes V)(W \otimes I_k)$. In particular, the blocks of U read

$$U_{ab} = (I_d \otimes V_{ab})W,$$

where V_{ab} are the $k \times k$ blocks of the unitary operator V . Multiplying the equation above with the adjoint of the same expression for another index pair (α, β) , we get

$$I_d \otimes V_{ab} V_{\alpha\beta}^* = \langle e_{ab}, e_{\alpha\beta} \rangle \tilde{V}_{ab} \tilde{V}_{\alpha\beta}^* \otimes f_{ab} f_{\alpha\beta}^*.$$

A contradiction occurs in the relation above if there is a quadruple (a, b, α, β) such that $e_{ab} \not\perp e_{\alpha\beta}$ and $\tilde{V}_{ab} \tilde{V}_{\alpha\beta}^* \notin \mathbb{C} I_d$.

7. ZERO BLOCK ALGEBRA

Let

$$\mathcal{A} = 0_{d_0} \oplus M_{d_1}(\mathbb{C})$$

be a subalgebra of $M_n(\mathbb{C})$ and

$$\mathbb{C}^n = V_0 \oplus V_1$$

the associated direct sum of orthogonal subspaces decomposition. In this decomposition, $d_0 + d_1 = n$ and $\{V_0, V_1\}$ is a partition of \mathbb{C}^n . In this section we want to characterize the bipartite unitary matrices generating UCP maps as in (1) (resp. TPCP maps as in (2)) preserving \mathcal{A} irrespective of the ancilla state β . It turns out that imposing the stability of \mathcal{A} for a given positive definite β is enough.

We consider the block decomposition of the bipartite matrices corresponding to the partition of \mathbb{C}^n associated to \mathcal{A} . Namely for any $X \in M_{nk}(\mathbb{C}) \cong M_n(M_k(\mathbb{C}))$, there exists four matrices, $X_{00} \in M_{d_0k}(\mathbb{C})$, $X_{01} \in M_{d_0k \times d_1k}(\mathbb{C})$, $X_{10} \in M_{d_1k \times d_0k}(\mathbb{C})$ and $X_{11} \in M_{d_1k}(\mathbb{C})$ such that

$$X = \begin{bmatrix} X_{00} & X_{01} \\ X_{10} & X_{11} \end{bmatrix}.$$

The stability of \mathcal{A} algebras in either the Schrödinger or Heisenberg pictures imposes the same constraints on the bipartite unitary matrices.

Theorem 7.1. *Let $U \in \mathcal{U}_{nk}$ and \mathcal{A} be the above subalgebra of $M_n(\mathbb{C})$. Then the following statements are equivalent:*

- (1) *There exists a set of quantum states \mathcal{B} spanning $M_k(\mathbb{C})$ such that for any $\beta \in \mathcal{B}$, the subalgebra \mathcal{A} is stable under the UCP map $S_{U,\beta}$:*

$$\forall \beta \in \mathcal{B}, \quad S_{U,\beta}(\mathcal{A}) \subset \mathcal{A}.$$

- (2) *There exists a set of quantum states \mathcal{B} spanning $M_k(\mathbb{C})$ such that for any $\beta \in \mathcal{B}$, the subalgebra \mathcal{A} is stable under the TPCP map $T_{U,\beta}$:*

$$\forall \beta \in \mathcal{B}, \quad T_{U,\beta}(\mathcal{A}) \subset \mathcal{A}.$$

- (3) *It holds that*

$$U = \begin{bmatrix} U_{00} & 0 \\ 0 & U_{11} \end{bmatrix}$$

with U_{00} and U_{11} unitary matrices.

The implications (1) \implies (3) and (2) \implies (3) hold if the stability of the algebra \mathcal{A} holds for a positive definite state β . In other words if \mathcal{B} is replaced in respectively (1) and (2) by a singlet $\mathcal{B} = \{\beta\}$ with $\beta > 0$.

Proof. We start with the implication (1) \implies (3). Statement (1) is equivalent to

$$\text{Tr}(X S_{U,\beta}(Y)) = 0$$

for any $X \in M_n(\mathbb{C})$ positive semidefinite such that $X_{11} = 0$ and $Y \in M_n(\mathbb{C})$ positive semidefinite such that $Y_{00} = 0$. From the definition of $S_{U,\beta}$ in (1), we get

$$\text{Tr}(U^* Y \otimes I_k U X \otimes \beta) = 0.$$

Since $\beta > 0$ and, X and Y are positive semidefinite, there exists a constant $c > 0$ such that,

$$\text{Tr}(U^* Y \otimes I_k U X \otimes \beta) \geq c \text{Tr}(U^* Y \otimes I_k U X \otimes I_k).$$

Thus, (1) implies,

$$\text{Tr}(U^* Y \otimes I_k U X \otimes I_k) = 0$$

for any $X \in M_n(\mathbb{C})$ positive semidefinite such that $X_{11} = 0$ and $Y \in M_n(\mathbb{C})$ positive semidefinite such that $Y_{00} = 0$. Choosing $X = P_0$ and $Y = P_1$ with P_i the orthogonal projector on V_i ,

$$\mathrm{Tr}(U^* P_1 \otimes I_k U P_0 \otimes I_k) = 0.$$

Hence $\|U_{10}\|_{HS} = 0$ where $\|\cdot\|_{HS}$ is the Hilbert–Schmidt norm. Since U is a unitary matrix, U_{01} implies $U_{11}U_{11}^* = I_{d_1}$ and $U_{00}^*U_{00} = I_{d_0}$. Hence both U_{00} and U_{11} are full rank and thus unitary matrices by Cochran’s Lemma 3.4. Using again the fact that U is unitary, $U_{11}U_{01}^* = 0$ yields statement (3).

The proof of (2) \implies (3) is similar. Statement (2) is equivalent to

$$\mathrm{Tr}(XT_{U,\beta}(Y)) = 0$$

for any $X \in M_n(\mathbb{C})$ positive semi definite such that $X_{11} = 0$ and $Y \in M_n(\mathbb{C})$ positive semi definite such that $Y_{00} = 0$. From the definition of $T_{U,\beta}$ in (2),

$$\mathrm{tr}(X \otimes I_k U Y \otimes \beta U^*) = 0.$$

Since $\beta > 0$, taking $X = P_0$ and $Y = P_1$ we deduce, $U_{01} = 0$. Using again the fact that U is unitary, statement (3) follows.

The proof of the implications (3) \implies (1) and (3) \implies (2) are straightforward once one remarks that (3) implies that $U(V_1 \otimes \mathbb{C}^k) \subset V_1 \otimes \mathbb{C}^k$. \square

Remark 7.2. *Imposing a finer subalgebra structure to \mathcal{A} amounts to apply one of the appropriate theorems from previous sections to the unitary bloc U_{11} .*

8. GENERATING RANDOM STRUCTURED BIPARTITE UNITARY OPERATORS

We discuss in this section the natural probability measure one can consider on the sets of bipartite unitary operators appearing in Theorems 4.1,4.4,5.1,5.2,6.1,6.2. We shall discuss each problem separately, in the order of increasing difficulty.

Let us start with the set of unitary operators described in Theorem 4.1; these are bipartite operators $U = (U_{ij})_{i,j=1}^n$ with the property that the blocks $U_{ij} \in M_k(\mathbb{C})$ are partial isometries satisfying conditions (C2),(C3) from Definition 3.2. Let us denote by $\delta_{ij} = \dim E_{ij}$. From condition (C3), we deduce that

$$\forall j \in [n], \quad \sum_{i=1}^n \delta_{ij} = k.$$

Since U_{ij} is a partial isometry, we also have $\delta_{ij} = \dim F_{ij}$, and thus, from condition (C2), we get

$$\forall i \in [n], \quad \sum_{j=1}^n \delta_{ij} = k.$$

We conclude that the non-negative integer matrix $\delta = (\delta_{ij})_{i,j=1}^n$ has the property that each of its rows and columns forms a partition of k . For each such *pattern matrix* δ , we construct the following probability measure on the set of unitary matrices U .

Random bipartite unitary operators satisfying (C2),(C3) with a given pattern

- (1) **Input:** A pattern matrix δ .
- (2) Consider $2n$ i.i.d., Haar distributed unitary random matrices $R_1, \dots, R_n, C_1, \dots, C_n \in \mathcal{U}_k$. Denote by $R_i(j)$ the j -th column of the matrix R_i ; similarly for $C_i(j)$.
- (3) Define the input spaces E_{ij} as follows:

$$\forall i, j \in [n], \quad E_{ij} := \mathrm{span} \left\{ C_j \left(\sum_{t < i} \delta_{tj} + s \right) \right\}_{s=1}^{\delta_{ij}},$$

and the output spaces F_{ij} as

$$\forall i, j \in [n], \quad F_{ij} := \text{span} \left\{ R_i \left(\sum_{t < j} \delta_{it} + s \right) \right\}_{s=1}^{\delta_{ij}}.$$

- (4) For all $i, j \in [n]$, the partial isometry U_{ij} is defined by its action on E_{ij} , the orthogonal of its kernel:

$$\forall s \in [\delta_{ij}], \quad U_{ij} C_j \left(\sum_{t < i} \delta_{tj} + s \right) = R_i \left(\sum_{t < j} \delta_{it} + s \right).$$

- (5) **Output:** $U = \sum_{i,j=1}^n e_i e_j^* \otimes U_{ij}$, a random unitary matrix satisfying the conditions from Theorem 5.1.

Note that the choice of the pattern matrix δ in the algorithm above is arbitrary. A canonical choice only appears when $k = n$, in which case one can choose $\delta_{ij} = 1$, for all $i, j \in [n]$. The case of unitary operators appearing in Theorem 5.1 is dealt with in a similar manner, we leave the details to the reader.

Let us now consider bipartite unitary operators that satisfy the conditions from Theorem 6.1. Such operators admit a decomposition $U = (I_d \otimes V)(W \otimes I_r)$ for other unitary matrices $V \in \mathcal{U}_{rk}$ and $W \in \mathcal{U}_{dk}$, and it is natural to choose V and W to be independent, Haar distributed in their respective group. Note that this probability measure does not give the full Haar measure on the group \mathcal{U}_{drk} , since the operators V and W “interact” only on the space \mathbb{C}^k . Counting parameters, we find that the real dimension of the set of U ’s is $k^2(d^2 + r^2 - 1)$.

Regarding operators which give quantum channels preserving tensor product algebras (Theorem 6.2), the situation is more complicated, since there is not an obvious way to sample uniformly from the set $\mathcal{U}_{\text{unital}}$ from (17), see also [11, Section 3]. We conjecture that the following algorithm will converge to an element of $\mathcal{U}_{\text{unital}}$.

Sampling from $\mathcal{U}_{\text{unital}}$

- (1) **Input:** Integers n, k and an error parameter $\varepsilon > 0$.
- (2) Start with a Haar distributed unitary random unitary operator $U \in \mathcal{U}_{nk}$.
- (3) While $\|U^\Gamma (U^\Gamma)^* - I_{nk}\|_2 > \varepsilon$, repeat the next step:
- (4) $U \leftarrow \text{Pol}(U^\Gamma)$, where $\text{Pol}(X)$ is the unitary operator V appearing in the polar decomposition of X : $X = VP$ with $P \geq 0$.
- (5) **Output:** U , an operator at distance at most ε from $\mathcal{U}_{\text{unital}}$.

In Figure 4, we present numerical evidence supporting our conjecture that the algorithm above converges. Note that an obstruction to the convergence of the algorithm would be an example of a matrix $U \in \mathcal{U}_{nk}$ such that

$$U^\Gamma \neq U = \text{Pol}(U^\Gamma);$$

on such an input, the loop would be stuck on $U \notin \mathcal{U}_{\text{unital}}$. We do not know whether such matrices exist or not. An implementation of the algorithm above can be found at [5].

Finally, let us discuss the case of unitary operators producing quantum channels which preserve diagonal subalgebras, see Theorem 4.4. Generating such a matrix of partial isometries is very similar to what we have done in the Heisenberg case, with just one exception: the output subspaces need to partition \mathbb{C}^k both row-wise and column-wise. Let us assume, for the sake of simplicity, that $n = k$ and $\dim F_{ij} = 1$, for all $i, j \in [n]$; we denote by x_{ij} the unit vector (up to a phase) which spans F_{ij} . We recover the following definition from [14].

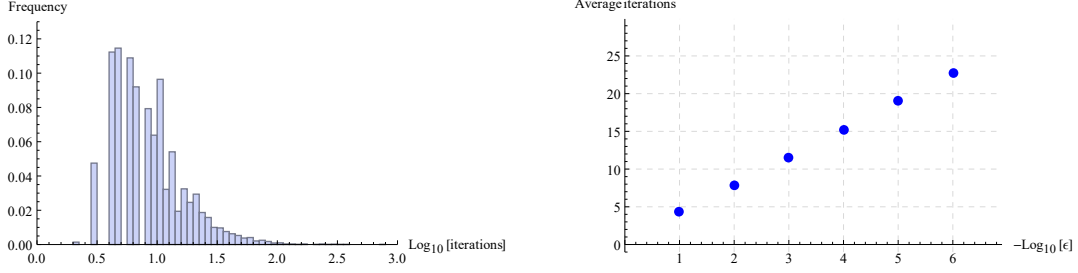

FIGURE 4. Numerical evidence supporting the claim that algorithm that samples from $\mathcal{U}_{\text{unitary}}$ converges. On the left panel, a histogram of the logarithm of the number of iterations that the algorithm needs to terminate for $n = k = 2$ and $\varepsilon = 10^{-3}$, ran on 10^5 random input data. On the right panel, for the same size parameters, the average number of steps the algorithm needs to converge, for different values of ε .

Definition 8.1. A quantum Latin square (QLS) of order n is a matrix $X = (x_{ij})_{i,j=1}^n$, where $x_{ij} \in \mathbb{C}^n$ are such that the vectors on each row (resp. column) of X form an orthonormal basis of \mathbb{C}^n .

We present next a conjectural algorithm for generating QLS. The main idea is to look at the projections on the vectors x_{ij} : $p_{ij} = x_{ij}x_{ij}^*$. Then, for some fixed column j , the fact that the vectors $\{x_{ij}\}_{i=1}^n$ form an orthonormal basis of \mathbb{C}^n is equivalent to the following equality (a similar relation holds for the rows): $\sum_{i=1}^n p_{ij} = I_n$. Since this relation is similar to some probabilities summing up to one, we draw a parallel between QLS and bistochastic matrices. Our algorithm is thus an adaptation of the classical Sinkhorn-Knopp algorithm for generating bistochastic matrices [17, 18]. Although the procedure resembles Gurvits' algorithm [12] called "operator scaling", we have not been able to reduce it to operator scaling. Note also that the algorithm below also appears in the representation theory of the quantum symmetric group S_N^+ , see [3]. For a 3-tensor X , define the following $2n$ matrices, which have the vectors x_{ij} as columns:

$$\begin{aligned} \forall i \in [n], \quad R_i &= \sum_{j=1}^n x_{ij}e_j^* \\ \forall j \in [n], \quad C_j &= \sum_{i=1}^n x_{ij}e_i^*. \end{aligned}$$

We say that X is an ε -QLS if it is close to being a QLS, in the following sense:

$$\sum_{i=1}^n \|R_i R_i^* - I_n\|_2^2 + \sum_{j=1}^n \|C_j C_j^* - I_n\|_2^2 \leq \varepsilon^2.$$

Non-commutative Sinkhorn algorithm for sampling QLS

- (1) **Input:** The dimension n and an error parameter $\varepsilon > 0$
- (2) Start with x_{ij} independent uniform points on the unit sphere of \mathbb{C}^n .
- (3) While X is not an ε -QLS, do the steps (4-6)
- (4) Define the matrix Y by making the rows of X unitary:

$$\forall i \in [n], \quad y_{ij} = \text{Pol} \left(\sum_{s=1}^n x_{is}e_s^* \right) \cdot e_j.$$

(5) Define the matrix Z by making the rows of Y unitary:

$$\forall j \in [n], \quad z_{ij} = \text{Pol} \left(\sum_{s=1}^n y_{sj} e_s^* \right) \cdot e_i.$$

(6) $X \leftarrow Z$.

(7) **Output:** X , an ε -QLS.

We conjecture that the algorithm above converges almost surely (for a computer implementation, see [5]). Again, the proof of this important result is elusive at this time, but we have numerical evidence (see Figure 5), as well as a proof of a relaxed version, where we replace the rank-1 projectors p_{ij} with positive definite operators, see Appendix A.

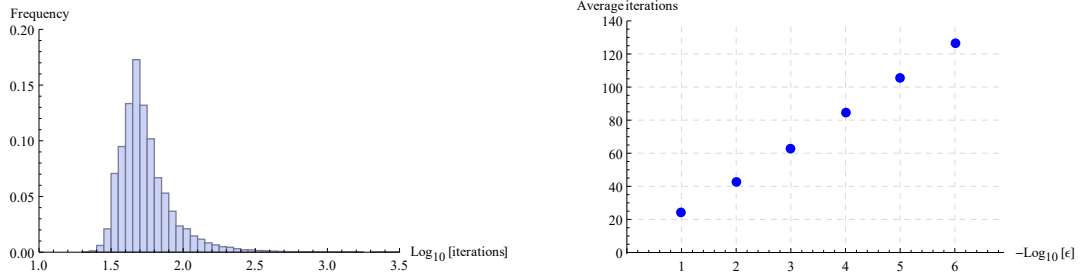

FIGURE 5. Numerical evidence supporting the claim that algorithm that samples Quantum Latin Squares converges. On the left panel, a histogram of the logarithm of the number of iterations that the algorithm needs to terminate for $n = 2$ and $\varepsilon = 10^{-3}$, ran on 10^5 random input data. On the right panel, for the same size parameter, the average number of steps the algorithm needs to converge, for different values of ε .

APPENDIX A. A NON-COMMUTATIVE SINKHORN ALGORITHM: THE INVERTIBLE CASE

We present in this section a non-commutative version of the classical Sinkhorn algorithm [17, 18]. The goal of the algorithm is to produce, starting from a matrix $X = (X_{ij})_{i,j=1}^n$ of positive definite blocks $M_k(\mathbb{C}) \ni X_{ij} > 0$ another block matrix $Y = (Y_{ij})$ having the following two properties:

$$\forall i \in [n], \quad \sum_{j=1}^n Y_{ij} = I_k$$

$$\forall j \in [n], \quad \sum_{i=1}^n Y_{ij} = I_k.$$

A block matrix having the two properties above will be called a *block-bistochastic* matrix. As in the classical case, we shall need to define an approximate notion of block-bistochasticity: given some positive $\varepsilon > 0$, we call Y ε -block-bistochastic if

$$\forall i \in [n], \quad \|I_k - \sum_{j=1}^n Y_{ij}\| \leq \varepsilon$$

$$\forall j \in [n], \quad \|I_k - \sum_{i=1}^n Y_{ij}\| \leq \varepsilon.$$

Let us introduce now the non-commutative variant of the classical Sinkhorn algorithm.

Non-commutative Sinkhorn algorithm, the invertible case

- (1) **Input:** A block matrix $X \in M_n(M_k(\mathbb{C}))$ with positive definite blocks $X_{ij} > 0$ and some positive precision parameter $\varepsilon > 0$
- (2) Let $Y = X$
- (3) While Y is not ε -block-bistochastic, do the steps (4-6)
- (4) Define the block matrix Y' by normalizing the rows of Y :

$$Y'_{ij} = \left(\sum_{s=1}^n Y_{is} \right)^{-1/2} Y_{ij} \left(\sum_{s=1}^n Y_{is} \right)^{-1/2}$$

- (5) Define the block matrix Y'' by normalizing the columns of Y' :

$$Y''_{ij} = \left(\sum_{s=1}^n Y'_{sj} \right)^{-1/2} Y'_{ij} \left(\sum_{s=1}^n Y'_{sj} \right)^{-1/2}$$

- (6) Let $Y = Y''$
- (7) **Output:** Y , a ε -block-bistochastic matrix.

Before proving that the algorithm above finishes after a finite number of steps, let us note that the inverses used in steps (4) and (5) are well-defined. Indeed, it is easy to check that at each step, the matrices Y, Y', Y'' have positive definite blocks (we assume that the input X has this property), and thus their row-sums and column-sums are also positive definite (and thus invertible) $k \times k$ matrices.

Proposition A.1. *For any input X having positive definite blocks and any precision parameter $\varepsilon > 0$, the algorithm above stops after a finite number of steps.*

Proof. Our proof is a natural extension of the proof in [1]. On the set $\mathcal{X}_{n,k}$ of $n \times n$ block matrices with strictly positive $k \times k$ blocks X_{ij} , we introduce the function $F : \mathcal{X}_{n,k} \rightarrow [0, \infty)$ given by

$$F(X) = \prod_{i,j=1}^n \det X_{ij}.$$

Let us now consider a matrix $Y \in \mathcal{X}_{n,k}$ with the property that the columns of Y are normalized, i.e. $\forall j \in [n], \sum_{i=1}^n Y_{ij} = I_k$. We claim that $F(Y) \leq 1$. Indeed, this is a consequence of the arithmetic-geometric (AG) mean inequality, as follows:

$$\begin{aligned} F(Y) &= \prod_{i,j=1}^n \det Y_{ij} \leq \prod_{i,j=1}^n \left(\frac{\text{Tr } Y_{ij}}{n} \right)^n \\ &\leq \left(\frac{1}{n^2} \sum_{i,j=1}^n \frac{1}{n} \text{Tr } Y_{ij} \right)^{n^3} \\ &= \left(\frac{1}{n^3} \sum_{j=1}^n \text{Tr} \sum_{i=1}^n Y_{ij} \right)^{n^3} = n^{-n^3} \leq 1. \end{aligned}$$

So, if we denote by Y_1, Y_2, \dots the matrices Y which enter the algorithm at step (4), then we have $F(Y_r) \leq 1$, for all $r \geq 2$. We show now that, along the ‘‘trajectory’’ Y_1, Y_2, \dots , the functional F is increasing. We shall assume that $r \geq 2$ (Y entering step (4) has normalized columns) and we shall prove that $F(Y) \leq F(Y')$. The inequality $F(Y') \leq F(Y'')$ can be proved in a similar manner. We have

$$F(Y') = \prod_{i,j=1}^n \det Y'_{ij} = \prod_{i,j=1}^n \frac{\det Y_{ij}}{\det \sum_{s=1}^n Y_{is}} = \frac{F(Y)}{\left(\prod_{i=1}^n \det \sum_{s=1}^n Y_{is} \right)^n},$$

and thus it is enough to show that

$$\left(\prod_{i=1}^n \det \sum_{s=1}^n Y_{is} \right)^n \leq \left(\prod_{i=1}^n \left(\frac{1}{n} \operatorname{Tr} \sum_{s=1}^n Y_{is} \right)^n \right)^n \quad (19)$$

$$\leq \left(\frac{1}{n} \sum_{i=1}^n \frac{1}{n} \sum_{s=1}^n \operatorname{Tr} Y_{is} \right)^{n^3} \quad (20)$$

$$= \left(\frac{1}{n^2} \sum_{s=1}^n \operatorname{Tr} \sum_{i=1}^n Y_{is} \right)^{n^3} = 1. \quad (21)$$

We have thus shown that the function $r \mapsto F(Y_r)$ is increasing and bounded along a run Y_1, Y_2, \dots of the algorithm, so it must converge to some value $f_\infty \in [0, 1]$. In particular, the quantity appearing on the left hand side of (19) converges to 1, as $r \rightarrow \infty$. As a consequence, the AG mean inequalities which were used in (19) were almost equalities: given ε , there is some $R \geq 2$ such that, for all $r \geq R$ and all $i \in [n]$,

$$(1 - \varepsilon) \left(\frac{1}{n} \operatorname{Tr} \sum_{s=1}^n Y_{is} \right)^n \leq \det \sum_{s=1}^n Y_{is} \leq \left(\frac{1}{n} \operatorname{Tr} \sum_{s=1}^n Y_{is} \right)^n.$$

It is a classical fact (see, e.g. [13]) that this implies that the numbers appearing in the AG inequality should be, up to some constants depending on n , ε -close to their mean; in our case this translates to the matrices $\sum_{i=1}^s Y_{is}$ being close to a multiple of the identity, which is our ε -block-bistochastic condition. \square

REFERENCES

- [1] Aaronson, S. *Quantum computing and hidden variables*. Phys. Rev. A, 71(3), 032325 (2005). 23
- [2] Adler, S. L., Brody, D. C., Brun T. A., Hughston L. P. *Martingale models for quantum state reduction*. J. Phys. A 34, 8795 (2001) 2
- [3] Banica, T., Nechita, I. *Universal models for quantum permutation groups*. Preprint arXiv:1602.04456. 21
- [4] Bardet, I. *Quantum extensions of dynamical systems and of Markov semigroups*. Preprint arXiv:1509.04849. 2
- [5] Benoist, T., Nechita, I. *Computer implementation of some algorithms appearing in the current paper*. See supplementary materials. 20, 22
- [6] Bauer, M., Bernard, D. *Convergence of repeated quantum nondemolition measurements and wave-function collapse*. Phys. Rev. A 84, 044103 (2011) 2
- [7] Bauer M, Benoist T and Bernard D *Repeated quantum non-demolition measurements: convergence and continuous-time limit* Ann. H. Poincaré 14, 639–679 (2013) 2
- [8] Benoist, T., Pellegrini, C. *Large Time Behavior and Convergence Rate for Quantum Filters under Standard Non Demolition Conditions*. Comm. Math. Phys. 331, 703–723 (2014) 2
- [9] Cochran, W. G. *The distribution of quadratic forms in a normal system, with applications to the analysis of covariance*. Math. Proc. Cambridge 30, 178–191 (1934). 5
- [10] Davidson, K.R. *C*-algebras by example*. Am. Math. Soc. (1996). 3
- [11] Deschamps, J., Nechita, I., Pellegrini, C. *On some classes of bipartite unitary operators*. J. Phys. A 49, 335301 (2016). 2, 15, 16, 20
- [12] Gurvits, L. *Classical complexity and quantum entanglement*. Journal of Computer and System Sciences 69.3, pp 448–484 (2004). 21
- [13] Kober, H. *On the arithmetic and geometric means and on Hölder’s inequality*. P. Am. Math. Soc. 9, 452–459 (1958). 24
- [14] Musto, B., Vicary, J. *Quantum Latin squares and unitary error bases*. Preprint arXiv:1504.02715. 2, 20
- [15] Nielsen, M., and Chuang, I. *Quantum computation and quantum information*. Cambridge University Press, 2010. 3
- [16] Paulsen, V. *Completely bounded maps and operator algebras*. Cambridge University Press (2002). 3
- [17] Sinkhorn, R. *A relationship between arbitrary positive matrices and doubly stochastic matrices*. Ann. Math. Stat., 35 876–879 (1964). 21, 22
- [18] Sinkhorn, R. and Knopp, P. *Concerning nonnegative matrices and doubly stochastic matrices*. Pac. J. Math. 21, 343–348 (1967). 21, 22

- [19] Stinespring, W. F. *Positive functions on C^* -algebras*. P. Am. Math. Soc. 6, 211–216 (1955). [1](#)
- [20] Stockton, J., van Handel, R., Mabuchi, H. *Deterministic Dick-state preparation with continuous measurement and control*. Phys. Rev. A 70, 022106 (2004) [2](#)
- [21] van Handel, R., Stockton, J., Mabuchi, H. *Feedback control of quantum state reduction*. IEEE Trans. Autom. Control 50, 768 (2005) [2](#)
- [22] Wolf, M. *Quantum channels & operations: Guided tour*. Lecture notes available [online](#), July 2012. [3](#)

CNRS, LABORATOIRE DE PHYSIQUE THÉORIQUE, TOULOUSE, FRANCE
E-mail address: `tristan.benoist@irsamc.ups-tlse.fr`

CNRS, LABORATOIRE DE PHYSIQUE THÉORIQUE, TOULOUSE, FRANCE
E-mail address: `nechita@irsamc.ups-tlse.fr`