



HAL
open science

Optimal selection of weighting functions by genetic algorithms to design H_∞ Anti-roll bar controllers for heavy vehicles

van Tan Vu, Olivier Sename, Luc Dugard, Peter Gaspar

► To cite this version:

van Tan Vu, Olivier Sename, Luc Dugard, Peter Gaspar. Optimal selection of weighting functions by genetic algorithms to design H_∞ Anti-roll bar controllers for heavy vehicles. VSDIA 2016 - 15th Mini Conference on Vehicle System Dynamics, Identification and Anomalies, Nov 2016, Budapest, Hungary. hal-01361861

HAL Id: hal-01361861

<https://hal.science/hal-01361861v1>

Submitted on 7 Sep 2016

HAL is a multi-disciplinary open access archive for the deposit and dissemination of scientific research documents, whether they are published or not. The documents may come from teaching and research institutions in France or abroad, or from public or private research centers.

L'archive ouverte pluridisciplinaire **HAL**, est destinée au dépôt et à la diffusion de documents scientifiques de niveau recherche, publiés ou non, émanant des établissements d'enseignement et de recherche français ou étrangers, des laboratoires publics ou privés.

OPTIMAL SELECTION OF WEIGHTING FUNCTIONS BY GENETIC ALGORITHMS TO DESIGN H_∞ ANTI-ROLL BAR CONTROLLERS FOR HEAVY VEHICLES

Van Tan VU¹, Olivier SENAME¹, Luc DUGARD¹, Peter GASPAR²

¹Univ. Grenoble Alpes and CNRS, GIPSA-lab, F-38402 Grenoble Cedex, France

E-mail: {Van-Tan.Vu, olivier.sename, luc.dugard}@gipsa-lab.grenoble-inp.fr

²Systems and Control Laboratory, Institute for Computer Science and Control, Hungarian Academy of Sciences, Kende u. 13-17, H-1111 Budapest, Hungary

E-mail: gaspar@sztaki.mta.hu

ABSTRACT

Multi-criterion optimization is so far popular for many complex engineering problems. The objective of active anti-roll bar of heavy vehicles is to maximize roll stability to prevent rollover in dangerous cases. However, such a performance objective must be balanced with the energy consumption of the anti-roll bar system, which is not a trivial task. In a previous work, the authors proposed an H_∞ active anti-roll bar controller for which the weighting functions were chosen by trials and errors during the design step. In this paper, Genetic Algorithms (GAs) are proposed to find optimal weighting functions for the H_∞ control synthesis. Such a general procedure is applied to the case of active anti-roll bar control in heavy vehicles. Thanks to GAs, the conflicting objectives between roll stability and torques generated are handled using one high level parameter only. The multi-criterion optimization solution is illustrated via the Pareto frontier. Simulations, performed in the frequency and time domains, emphasize the efficiency of the proposed method.

Keywords: H_∞ control, Genetic Algorithms, Heavy vehicle, Active anti-roll bar control, Rollover, Roll stability.

1. INTRODUCTION

1.1 Context

Rollover of heavy vehicle is an important road safety problem world-wide. Although rollovers are relatively rare events, they are usually deadly accidents when they occur. Moreover, the roll stability loss is the main cause of traffic accidents in which heavy vehicles are involved. In order to improve the roll stability, several schemes with possible active intervention into the vehicle dynamics were proposed. One of them employs active anti-roll bars, that is, a pair of hydraulic actuators which generates a stabilizing moment to counter balance the overturning moment [17].

On the other hand, the H_∞ control design approach is an efficient tool for improving the performance of a closed-loop system in pre-defined frequency ranges. The key step of the H_∞ control design is the selection of weighting functions. In many applications, the difficulty in choosing these functions still increases as performance specification is not accurately defined i.e., it is simply to achieve the best possible performance (optimal design) or to achieve an optimally joint improvement of more than one objective (multi-objectives design). So the weighting functions optimization to satisfy

the desired performances is still an open problem. Recently, Genetic Algorithms were used in [1] and [10], their formulation well suited for this type of problematic [4].

1.2 Related works

Some of the control methods applied to active anti-roll bar control on heavy vehicle are briefly recalled below:

a- Optimal control: Sampson et al [12], [13], [14] proposed a state feedback controller which was designed by finding an optimal controller based on a linear quadratic regulator (LQR) for single unit and articulated heavy vehicles.

The LQR was also applied to an integrated model including an electronic servo-valve hydraulic damper model and a yaw-roll model of a single unit heavy vehicle. The input current of the electronic servo-valve is the input control signal [17].

b- Neural network control: A reinforcement learning algorithm using neural networks was used to improve the roll stability for a single unit heavy vehicle [2].

c- Robust control (LPV): Gaspar et al [5], [6], [7] applied Linear Parameter Varying techniques to control active anti-roll bars combined with active brakes on a single unit heavy vehicle. The forward velocity was the varying parameter.

1.3 Paper contribution

Based on the H_∞ active anti-roll bar control presented by the authors in [18], this paper proposes the use of Genetic Algorithms to define automatically the weighting functions. Hence the following contributions are brought:

- The Genetic algorithms method is applied to define the weighting functions of the H_∞ robust controller for active anti-roll bar system on the single unit heavy vehicle. Thanks to GAs, the conflicting objectives between the normalized load transfers and the generated torques are handled using a single high level parameter only, denoted α .

- The simulation results in frequency and time domains show the normalized load transfers at two axles when the tuning parameter value α moves from 0 to 1, compared with the case of passive anti-roll bar and the results of [18]. In time domain, a cornering manoeuvre is used for the heavy vehicle. The forward velocity is considered up to 160 km/h to evaluate the roll stability and to determine the maximal velocity at which the normalized load transfers and the generated torques reach their limits.

The paper is organised as follows: Section 2 gives a brief introduction about multi-objective optimization using GAs. Section 3 presents the model of a single unit heavy vehicle. Section 4 develops the H_∞ control synthesis to prevent rollover of heavy vehicles. Section 5 illustrates how to use the GAs to define the weighting functions of the H_∞ active anti-roll bar. Section 6 presents some simulation results in frequency and time domains. Finally, some conclusions are drawn in section 7.

2. GENETIC ALGORITHMS AND MULTI-CRITERION OPTIMIZATION

2.1 Genetic algorithms

GAs are now widely used since the first study in [9], confirmed by a popular theory-oriented book [8] and an application-oriented book [3]. The algorithms are

based on the natural selection mechanism and have been proven to be very effective in optimization in many real applications such as finance and investment strategies, robotics, engineering design, telecommunications, etc. They are likely global optimization techniques (despite the high computational expense) using probabilistic, multi-points search, random combination (crossover, mutation) and information of previous iteration to evaluate and improve the population. A great advantage of GAs compared with other searching methods (for example gradient methods) is that they search regardless of the nature of the objective functions and constraints.

GAs initialize with a random population which evolves through genetic operations: *selection*, *crossover* and *mutation*. By using a selection process, the fittest individuals based on their fitness values are chosen; crossover and mutation are then applied to create the new population. The genetic operation on individuals continues until the optimization criterion is satisfied or a certain number of generations is reached.

Fitness function: The fitness of an individual is used to choose between “good” and “bad” individuals. An individual with a high fitness has a great chance to be selected.

Selection: This step is to sort and copy individuals by order of satisfaction of the fitness function. The higher the value of the fitness, associated to an individual, the greater the individual's chances to be selected to participate in the next generation. “Proportionate” [9] and “tournament” [11] selections are the most popular methods.

Crossover: This main operation acting on the population of parents is an exchange of parts of chains between two selected individuals (parents) to form two new individuals (children). This exchange may be due either to a single or multiple points.

Mutation: Mutation operates on a single individual by randomly changing a part of it. In the binary coding case, it is done by reversing one or more bits in a chromosome.

2.2 Multi-criterion optimization

One well-known application of the GAs is to find the optimal solution for the multi-objective optimization problem involving multiple and conflicting objectives. This is a very popular problem in practice and can be described as follows:

$$\min_{x \in C} F(x) = \begin{bmatrix} f_1(x) \\ f_2(x) \\ \vdots \\ f_{n_{obj}}(x) \end{bmatrix}, n_{obj} \geq 2, \quad (1)$$

where x is called the decision vector, C the set of possible decision vectors (or the searching space), and $F(x)$ the objective vector.

The existence of an ideal solution x^* that can simultaneously minimize all objective functions $f_1, f_2, \dots, f_{n_{obj}}$ is in fact rarely feasible.

There are many formulations to solve the problem (1) like weighted *min-max method*, *weighted global criterion method*, *goal programming methods*... [4] and references therein. One of the most popular and simple approaches is the weighted sum method which converts the multi-objective problem into a single objective one. In this paper, one uses a particular case of the weighted sum method, where the multi-objective functions vector F is replaced by the convex combination of objectives:

$$\min J = \sum_{i=1}^{n_{obj}} \alpha_i f_i(x), \text{ s.t. } x \in C, \sum_{i=1}^{n_{obj}} \alpha_i = 1 \quad (2)$$

The vector $\alpha = (\alpha_1, \alpha_2, \dots, \alpha_{n_{obj}})$ represents the gradient of function J . By using various sets of α , one can generate several points in the Pareto set [4].

3. SINGLE UNIT HEAVY VEHICLE MODEL

Fig 1 illustrates the combined yaw-roll dynamics of the vehicle modelled by a three-body system, where m_s is the sprung mass, m_{uf} the unsprung mass at the front including the front wheels and axle, and m_{ur} the unsprung mass at the rear with the rear wheels and axle. The model variables are given in Table 1 and the parameters in [5].

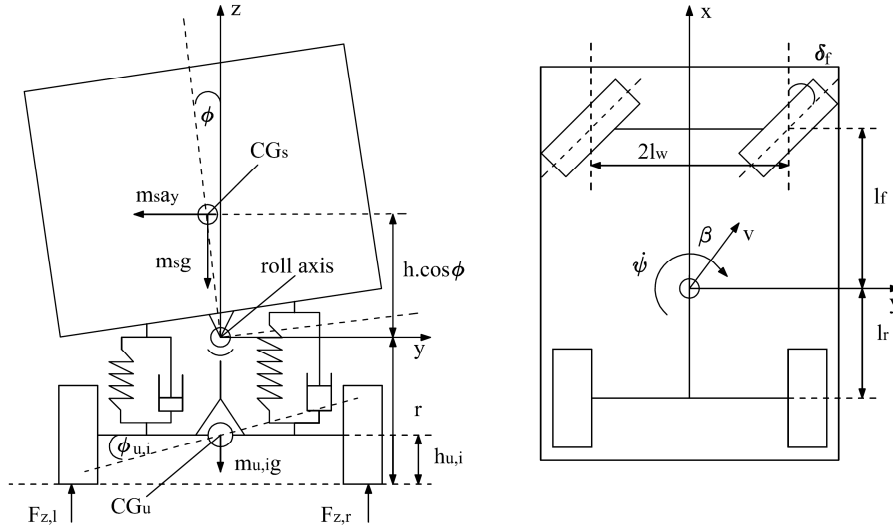

Fig. 1 Yaw-Roll model of single unit heavy vehicle [5].

Table 1: Variables of yaw-roll model.

Symbols	Description	Symbols	Description
m_s	Sprung mass	δ_f	Steering angle
$m_{u,f}$	Unsprung mass on the front axle	C_f	Tire cornering stiffness on the front axle
$m_{u,r}$	Unsprung mass on the rear axle	C_r	Tire cornering stiffness on the rear axle
m	The total vehicle mass	k_f	Suspension roll stiffness on the front axle
v	Forward velocity	k_r	Suspension roll stiffness on the rear axle
v_{wi}	Components of the forward velocity	b_f	Suspension roll damping on the front axle
h	Height of CG of sprung mass from roll axis	b_r	Suspension roll damping on the rear axle
$h_{u,i}$	Height of CG of unsprung mass from ground	k_{tf}	Tire roll stiffness on the front axle
r	Height of roll axis from ground	k_{tr}	Tire roll stiffness on the rear axle
a_y	Lateral acceleration	I_{xx}	Roll moment of inertia of sprung mass
β	Side-slip angle at center of mass	I_{xz}	Yaw-roll product of inertial of sprung mass
ψ	Heading angle	I_{zz}	Yaw moment of inertia of sprung mass
$\dot{\psi}$	Yaw rate	l_f	Length of the front axle from the CG
α	Side slip angle	l_r	Length of the rear axle from the CG
ϕ	Sprung mass roll angle	l_w	Half of the vehicle width
$\phi_{u,i}$	Unsprung mass roll angle	μ	Road adhesion coefficient

In the vehicle modelling, the differential equations of motion of the yaw-roll dynamics of the single unit vehicle, i.e. the lateral dynamics (3.1), the yaw moment (3.2), the roll moment of the sprung mass (3.3), the roll moment of the front (3.4) and the rear (3.5) unsprung masses, are formalized in the equations (3):

$$\begin{cases} mv(\beta + \psi) - m_s h \dot{\phi} = F_{yf} + F_{yr} \end{cases} \quad (3.1)$$

$$\begin{cases} -I_{xz} \dot{\phi} + I_{zz} \dot{\psi} = F_{yf} l_f - F_{yr} l_r \end{cases} \quad (3.2)$$

$$\begin{cases} (I_{xx} + m_s h^2) \ddot{\phi} - I_{xz} \ddot{\psi} = m_s g h \dot{\phi} + m_s v h (\beta + \psi) - k_f (\phi - \phi_{uf}) - b_f (\dot{\phi} - \dot{\phi}_{uf}) + M_{ARf} + U_f \\ \quad - k_r (\phi - \phi_{ur}) - b_r (\dot{\phi} - \dot{\phi}_{ur}) + M_{ARr} + U_r \end{cases} \quad (3.3)$$

$$\begin{cases} -r F_{yf} = m_{uf} v (r - h_{uf}) (\beta + \psi) + m_{uf} g h_{uf} \phi_{uf} - k_{uf} \phi_{uf} + k_f (\phi - \phi_{uf}) + b_f (\dot{\phi} - \dot{\phi}_{uf}) + M_{ARf} + U_f \end{cases} \quad (3.4)$$

$$\begin{cases} -r F_{yr} = m_{ur} v (r - h_{ur}) (\beta + \psi) - m_{ur} g h_{ur} \phi_{ur} - k_{ur} \phi_{ur} + k_r (\phi - \phi_{ur}) + b_r (\dot{\phi} - \dot{\phi}_{ur}) + M_{ARr} + U_r \end{cases} \quad (3.5)$$

The lateral tire forces F_{yf} and F_{yr} in the direction of velocity at the wheel ground contact points are modelled by a linear stiffness as:

$$\begin{cases} F_{yf} = \mu C_f \alpha_f \\ F_{yr} = \mu C_r \alpha_r \end{cases} \quad (4)$$

where the tyre side slip angles are given as:

$$\begin{cases} \alpha_f = -\beta + \delta_f - \frac{l_f \psi}{v} \\ \alpha_r = -\beta + \frac{l_r \psi}{v} \end{cases} \quad (5)$$

The moment of passive anti-roll bar impacts the unsprung and sprung masses at the front and rear axles as follows [17], [18]:

$$\begin{cases} M_{ARf} = 4k_{AOf} \frac{t_A t_B}{c^2} \phi - 4k_{AOf} \frac{t_A^2}{c^2} \phi_{uf} \\ M_{ARr} = 4k_{AO r} \frac{t_A t_B}{c^2} \phi - 4k_{AO r} \frac{t_A^2}{c^2} \phi_{ur} \end{cases} \quad (6)$$

where k_{AOf} , $k_{AO r}$ are respectively the torsional stiffness of the anti-roll bar at the front and rear axles, t_A half the distance of the two suspensions, t_B half the distance of the chassis and c the length of the anti-roll bars' arm.

Using the previous equation, the single unit heavy vehicle can be represented by the linear system in the state space form (7):

$$\begin{cases} \dot{x} = Ax + B_1 w + B_2 u \\ y = Cx \end{cases} \quad (7)$$

with the state vector: $x = \begin{bmatrix} \beta & \psi & \phi & \dot{\phi} & \phi_{uf} & \phi_{ur} \end{bmatrix}$, the disturbance input: $w = \begin{bmatrix} \delta_f \end{bmatrix}$

the control inputs: $u = [U_f \ U_r]$ and the output vector: $y = [\beta \ \psi \ \varphi \ \varphi \ \varphi_{uf} \ \varphi_{ur}]$.

4. H_∞ CONTROL SYNTHESIS OF ACTIVE ANTI-ROLL BAR ON HEAVY VEHICLES

4.1 Control objective, problem statement

The objective of the active anti-roll bar control system is to maximize the roll stability of the vehicle. Usually, an imminent rollover is detected when the calculated normalized load transfer reaches 1 (or -1), as explained hereafter. First, the lateral load transfer can be given by:

$$\Delta F_z = \frac{k_u \varphi_u}{l_w} \quad (8)$$

where k_u is the stiffness of tire, φ_u the roll angle of the unsprung mass and l_w the half of vehicle's width. Then, the lateral load transfer can be normalized w.r.t. the total axle load F_z as follows:

$$R = \frac{\Delta F_z}{F_z} \quad (9)$$

The normalized load transfer $R = \pm 1$ corresponds to the largest possible load transfer. In that case, the inner wheel in the bend lifts off.

While attempting to minimize the load transfer, it is also necessary to constrain the roll angles between the sprung and unsprung masses ($\varphi - \varphi_u$) so that they stay within the limits of the suspension travel (7-8deg), see [5].

The performance characteristic which is of most interest when designing the active anti-roll bar, is then the normalized load transfer. The chosen control objective is to minimize the effect of the steering angle on the normalized load transfer R , in the H_∞ framework. As explained later, the limitation of the torques $U_{f,r}$ generated by the actuators is also crucial for practical implementation.

4.2 Background on H_∞ control

The H_∞ control problem is formulated according to the generalized control structure shown in Fig 2 [15], [16].

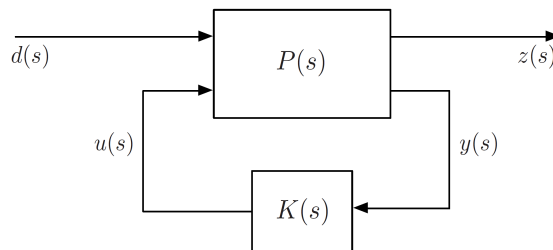

Fig. 2 Generalized control structure.

with P partitioned as:

$$\begin{bmatrix} z \\ y \end{bmatrix} = \begin{bmatrix} P_{11}(s) & P_{12}(s) \\ P_{21}(s) & P_{22}(s) \end{bmatrix} \begin{bmatrix} d \\ u \end{bmatrix} \quad (10)$$

and $u = K(s).y$, which yields:

$$\frac{z}{d} = F_l(P, K) := \left[P_{11} + P_{12}K[I - P_{22}K]^{-1}P_{21} \right] \quad (11)$$

The aim is to design a controller K that stabilizes the closed loop system and also reduces the signal transmission path from disturbances d to performance outputs z . This problem is then to find a controller K which minimizes γ such that

$$\|F_l(P, K)\|_{\infty} < \gamma \quad (12)$$

By minimizing a suitably weighted version of $F_l(P, K)$ the control aim is achieved.

4.3 H_{∞} control synthesis for the active anti-roll bar of the single unit heavy vehicle model

In this section, the H_{∞} control design is presented for the active anti-roll bar system on a single unit heavy vehicle. Consider the closed-loop system given in Fig 3, which includes the feedback structure of the nominal model G , the controller K and the weighting functions W_{ij} . In this diagram, U_f and U_r are the control inputs, y_1 and y_2 are the measured outputs, n_1 and n_2 are the measurement noises. δ_f is the steering angle considered as a disturbance signal, which is set by the driver. The variables z_1, z_2, z_3, z_4 and z_5 represent the performance outputs.

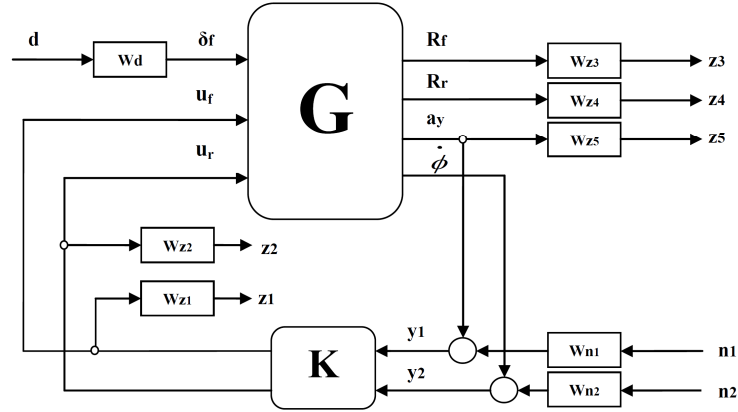

Fig. 3 G-K control structure of H_{∞} active anti-roll bar control.

According to Fig 3, the concatenation of the linear model (7) with performance weighting functions lead to the state space representation of $P(s)$:

$$\begin{bmatrix} \dot{X} \\ Z \\ Y \end{bmatrix} = \begin{bmatrix} A & B_1 & B_2 \\ C_1 & D_{11} & D_{12} \\ C_2 & D_{21} & D_{22} \end{bmatrix} \begin{bmatrix} X \\ W \\ U \end{bmatrix} \quad (13)$$

with the exogenous input (disturbance): $W = [d \ n_1 \ n_2]$

the control input: $U = [U_f \ U_r]^T$; where U_f/U_r are the torques at the front/rear axles.

the performance output vector: $Z = [z_1 \ z_2 \ z_3 \ z_4 \ z_5]^T$

the measured output vector: $Y = [a_y \ \dot{\phi}]^T$

and $A, B_1, B_2, C_1, D_{11}, D_{12}, C_2, D_{21}, D_{22}$ are matrices of appropriate dimensions.

The next section proposes an automatic and systematic way to obtain the optimal weighting functions used to solve the H_∞ control design problem.

5. SELECTION OF WEIGHTING FUNCTIONS OF H_∞ ANTI-ROLL BAR CONTROLLERS BY GENETIC ALGORITHMS

In industrial applications, multiple goals, often conflicting, have to be taken into account. Multi-criterion optimization (MCO) is then a powerful tool to find the best compromise solution balancing the conflicts, and is therefore of great importance in practice. In this section, MCO problem for the weighting function selection of the H_∞ active anti-roll bar control on heavy vehicles is introduced and solved using the Genetic algorithms method. But first, the criterion for MCO problem must be defined.

5.1 Optimization objectives

The objective of the active anti-roll bar control system is to maximize the roll stability of heavy vehicles to prevent rollover in dangerous cases. However, such a performance objective must be balanced with the energy consumption of the anti-roll bar system due to the torques generation by the actuators. Therefore the objective function is selected as follows:

$$f = \alpha f_{\text{Normalized_load_transfer}} + (1 - \alpha) f_{\text{Torque}} \quad (14)$$

where $f_{\text{Normalized_load_transfer}}$ and f_{Torque} are performance indices corresponding to the normalized load transfers and torques generated at two axles. They are defined as follows:

$$\left\{ \begin{array}{l} f_{\text{Normalized_load_transfer}} = \frac{1}{2} \left(\sqrt{\frac{1}{T} \int_0^T R_f^2(t) dt} + \sqrt{\frac{1}{T} \int_0^T R_r^2(t) dt} \right) \\ f_{\text{Torque}} = \frac{1}{2} \left(\frac{\sqrt{\frac{1}{T} \int_0^T U_f^2(t) dt}}{\sqrt{\frac{1}{T} \int_0^T U_f^2(t)_{\max} dt}} + \frac{\sqrt{\frac{1}{T} \int_0^T U_r^2(t) dt}}{\sqrt{\frac{1}{T} \int_0^T U_r^2(t)_{\max} dt}} \right) \end{array} \right. \quad (15)$$

where $R_{f,r}$ are the normalized load transfers and $U_{f,r}$ the torques generated at front and rear axles. $U_{f,rmax}$ are defined when the optimal problem focusses only on the normalized load transfers (i.e. the torques are then not considered in the optimisation problem). In that case, $\alpha = 1$ and $f = f_{\text{Normalized_load_transfer}}$.

5.2 Multi-criterion optimization problem formulation

The weighting functions used in Fig 3 are detailed in this part.

The input scaling weight W_d , chosen as $W_d = \frac{\pi}{180}$, normalizes the steering angle δ_f to the maximum expected value, corresponding to a I^0 steering angle command.

The weighting functions W_{n1} and W_{n2} are selected as: $W_{n1} = W_{n2} = 0.01$, which accounts for small sensor noise models in the control design. The noise weights are

chosen as $0.01(m/s^2)$ for the lateral acceleration and $0.01(^{\circ}/sec)$ for the derivative of the roll angle φ [5]. Note that other low pass filters could be selected if needed.

The weighting functions W_{zi} represent the performance outputs (W_{z1} , W_{z2} , W_{z3} , W_{z4} and W_{z5}). The purpose of the weighting functions is to keep small the control inputs, normalized load transfers and the lateral acceleration over a desired frequency range. The weighting functions chosen for performance outputs can be considered as penalty functions, that is, weights should be large in the frequency range where small signals are desired and small where larger performance outputs can be tolerated.

The weighting functions W_{z1} and W_{z2} corresponding to the front and rear control torques generated by active anti-roll bars are chosen as:

$$W_{z1} = \frac{1}{Z_1}; W_{z2} = \frac{1}{Z_2} \quad (16)$$

The weighting functions W_{z3} and W_{z4} corresponding to the normalized load transfers at front and rear axles are selected as:

$$W_{z3} = \frac{1}{Z_3}; W_{z4} = \frac{1}{Z_4} \quad (17)$$

The weighting function W_{z5} is selected as:

$$W_{z5} = Z_{51} \frac{Z_{52}s + Z_{53}}{Z_{54}s + Z_{55}} \quad (18)$$

Here, the weighting function W_{z5} corresponds to a design that avoids the rollover situation with the bandwidth of the driver in the frequency range up to more than $4rad/s$. This weighting function will directly minimize the lateral acceleration when it reaches the critical value, to avoid the rollover.

The parameters Z_{ij} are constant.

From equations (16) - (18), the following variables will then be defined: Z_1 , Z_2 , Z_3 , Z_4 , Z_{51} , Z_{52} , Z_{53} , Z_{54} , Z_{55} .

The MCO problem for the H_{∞} active anti-roll bar control can be defined as:

$$\min_{p \in P} f(p), f(p) := \left[f_{Normalized_load_transfer} \quad f_{Torque} \right]^T \quad (19)$$

$$P := \{ p = [Z_1, Z_2, Z_3, Z_4, Z_{51}, Z_{52}, Z_{53}, Z_{54}, Z_{55}]^T \in R \mid p^l \leq p \leq p^u \}$$

where $f(p)$ is the vector of objectives, p the vector of weighting function parameters, p^l and p^u the lower and upper bounds of the weighting function selection.

The lower and upper bounds of the weighting function parameters are given in Table (2). Besides the minimization of the objective function from equations (14) and (19), we also have to account for the limitations of the normalized load transfers, roll angle of suspensions as well as torques generated at each axle. These limitations are considered as the optimality conditions (binding conditions) shown in the Table (3).

Table 2: Lower and upper bounds of the weighting functions.

	W_{z1}	W_{z2}	W_{z3}	W_{z4}	W_{z5}				
	Z_1	Z_2	Z_3	Z_4	Z_{51}	Z_{52}	Z_{53}	Z_{54}	Z_{55}
Lower bound	50	50	0.1	0.1	0.5	$\frac{1}{3000}$	1	1	0.001

Upper bound	300000	300000	10	10	100	1	500	$\frac{1}{0.001}$	2
--------------------	--------	--------	----	----	-----	---	-----	-------------------	---

Table 3: Binding conditions.

No	Note	Maximum value	Unit
1	$ \phi - \phi_{if} $	< 7	deg
2	$ \phi - \phi_{ur} $	< 7	deg
3	$ R_f $	< 1	-
4	$ R_r $	< 1	-
5	$ U_f $	< 120000	Nm
6	$ U_r $	< 120000	Nm

5.3 Genetic operation

The selection method used in this paper is the proportionate selection developed by Holland [9]. This method assigns a probability of selection to each individual, proportional to its relative fitness. Proportionate selection can be illustrated by a roulette wheel. The crossover happens with a probability of 0.9 and the mutation happens with a very small probability 0.095.

The proposed weighting function optimization procedure for H_∞ active anti-roll bar control synthesis is as follows:

Step 1: Initialize with the weighting functions as in the previous paper [18], the vector of weighting function selected as $p=p_0$.

Step 2: Select lower bound, upper bound, scaling factor, offset and start point.

Step 3: Format optimal algorithm, select the vector of objectives with the variation of switch value from 0 to 1 and then solve the minimization problem.

Step 4: Select the individuals, apply crossover and mutation to generate a new generation: $p=p_{new}$.

Step 5: Evaluate the new generation by comparing with the binding conditions. If the criteria of interest are not satisfied, go to step 3 with $p=p_{new}$; else, stop and save the best individual: $p_{opt}=p_{new}$.

6. SIMULATION RESULTS

6.1 Optimization results

Thanks to the Genetic algorithms method, Table (4) synthesis the values of the variables Z_i , Z_{5j} in five cases for $\alpha = [1; 0.85; 0.65; 0.5; 0]$. When $\alpha = 1$, it means that $f = f_{\text{Normalized_load_transfer}}$, the optimal problem focuses only on the normalized load transfers and when $\alpha = 0$, it means that $f = f_{\text{Torque}}$, the optimal problem focuses only on the torques generated.

Table 4: Optimization results for the weighting functions of H_∞ active anti-roll bar.

Controllers	W_{z1}	W_{z2}	W_{z3}	W_{z4}	W_{z5}				
	Z_1	Z_2	Z_3	Z_4	Z_{51}	Z_{52}	Z_{53}	Z_{54}	Z_{55}
SSSC2016 [18]	150000	200000	1	1	1	0.0005	50	100	0.01
$\alpha = 1$	258762.34	259996.91	0.91	0.64	0.97	0.46	392.54	801.38	0.22
$\alpha = 0.85$	273598.36	295104.17	0.45	0.26	1.17	0.80	334.15	968.50	0.16
$\alpha = 0.65$	112322.78	110837.28	0.72	0.75	0.63	0.54	139.23	97.46	0.02
$\alpha = 0.5$	166902.22	196036.53	1.09	0.92	0.97	0.0005	54.19	116.64	0.01
$\alpha = 0$	50	50	1.59	0.83	0.50	0.43	1	683.05	0.024

Fig. 4 shows the conflicting relation between the normalized load transfers and torques generated with some Pareto-optimal points, computed for the active anti-roll bar on heavy vehicle. They are generated for different values of α in the range of $[0;1]$. For $\alpha=0$, f_{Torque} is minimized and conversely for $\alpha=1$, $f_{\text{Normalized_load_transfer}}$ is minimized.

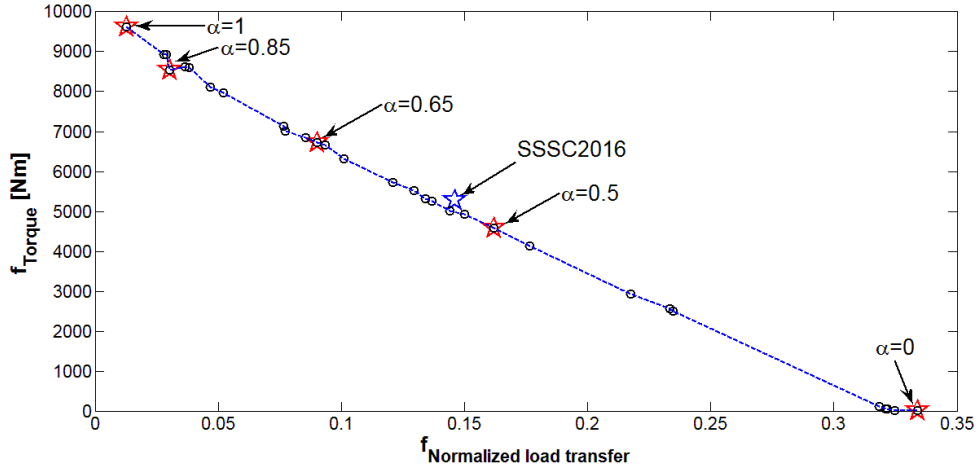

Figure. 4 The optimization results of some points in the Pareto frontier for the active anti-roll bar on heavy vehicle.

6.2 Evaluation of optimization results in frequency domain

The limited bandwidth of the driver must be considered up to 4rad/s to identify any resonances in the response that may be excited by the driver [5]. Therefore, it is necessary to consider the behavior of the heavy vehicle in a wider frequency range. In this section, the frequency response of heavy vehicle is shown in the nominal parameters case of the single unit heavy vehicle considered, characterized by the sprung mass $m_s = 12487\text{kg}$, the forward velocity V at 70Km/h and the road adhesion coefficient $\mu = 1$.

Fig 5 and 6 show the normalized load transfers at the two axles $R_{f,r}$. They show that in the cases $\alpha=[1;0.85;0.65]$, H_∞ active anti-roll bar controllers reduce well the normalized load transfers compared to that of the case passive anti-roll bar and of the case of the previous paper [18] which are chosen by trials and errors.

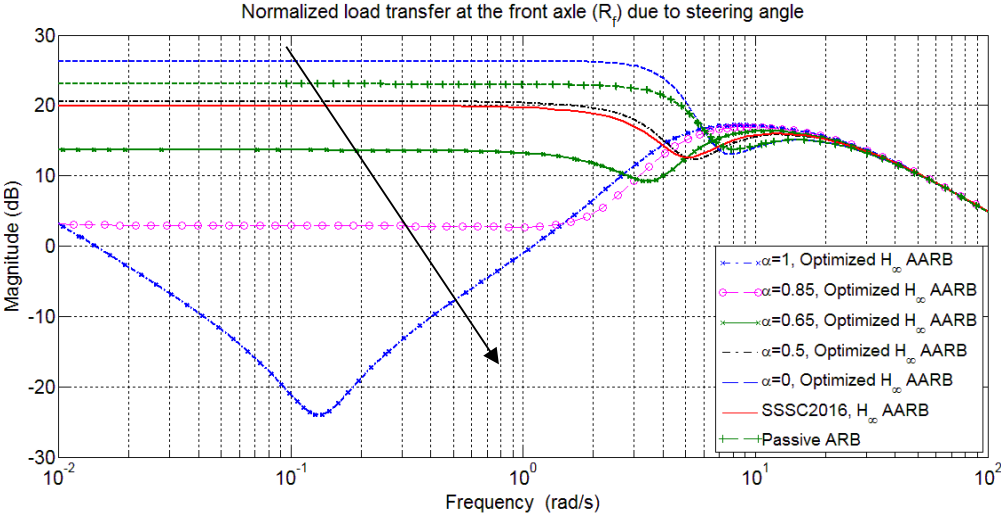

Figure. 5 Frequency responses of the normalized load transfer at the front axle (R_f) due to steering angle.

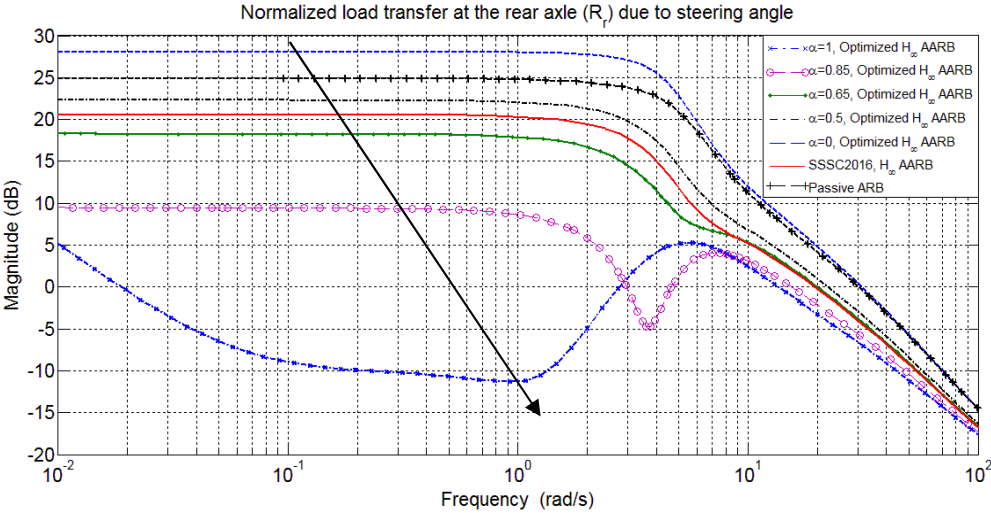

Figure. 6 Frequency responses of the normalized load transfer at the rear axle (R_r) due to steering angle.

6.3 Evaluation of optimization results in time domain

In this section, the considered vehicle maneuver is cornering [5].

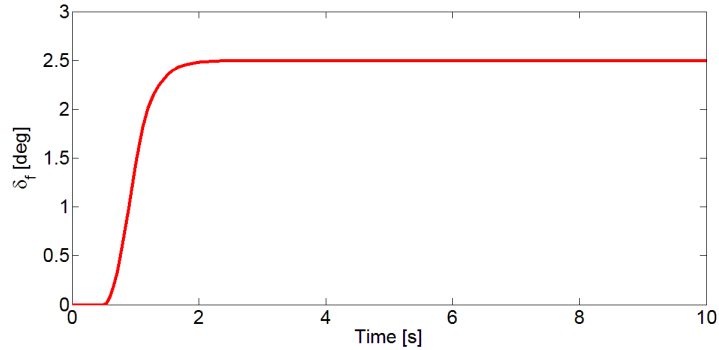

Figure. 7 Steering angle δ_f during cornering maneuver.

Fig 8a,b show the normalized load transfers and *Fig 8c,d* show the torques generated at two axles when the forward velocity is considered at 70Km/h . When the value of α increases, the controllers reduce the normalized load transfers, but the torques generated by the actuators are higher. This fulfills consistently the objective of optimal design.

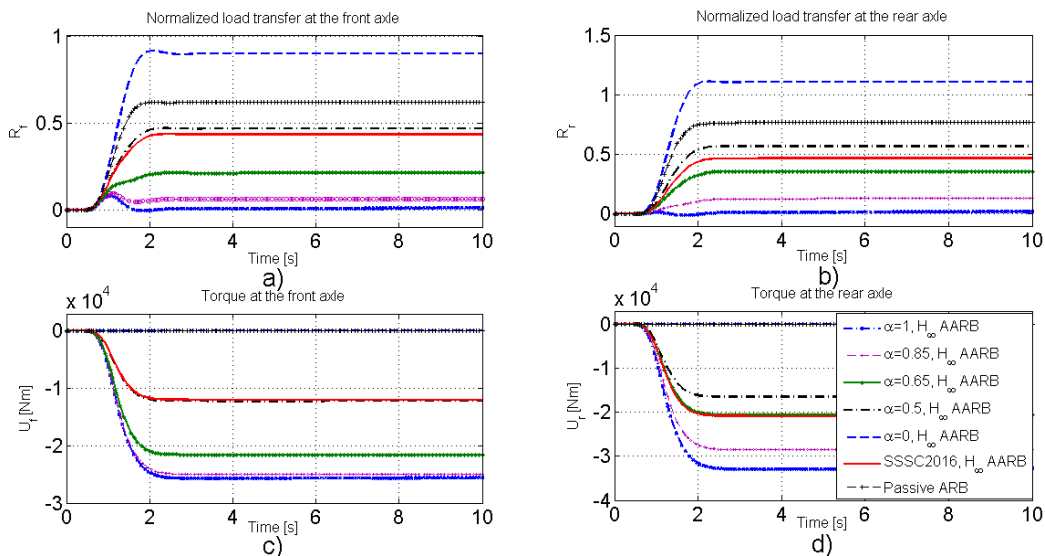

Figure. 8 Time responses of the normalized load transfers ($R_{f,r}$) and torques generated at the two axles.

The forward velocity of the heavy vehicle continuously varies during operation of the heavy vehicle, especially in the case of an emergency. The rollover of heavy

vehicle often occurs for forward velocity within 60 to 110 Km/h. In Fig 9 and 10 we consider the forward velocity of the heavy vehicle up to 160 Km/h in order to evaluate the roll stability, as well as to determine the maximum forward velocity at which the normalized load transfers and the torques generated reach the limitations. In what follows, the disturbance is the steering angle (δ_f) corresponding to a cornering maneuver. From Fig 9, we can see that the maximum absolute value of normalized load transfers at the front axle reaches the limit “1” in the case of $\alpha = [1; 0.85; 0.65; 0.5]$ where the forward velocities are respectively 134 , 131 , 123 , 104 Km/h. Note that in the previous paper [18] we got 107 Km/h for the forward velocity.

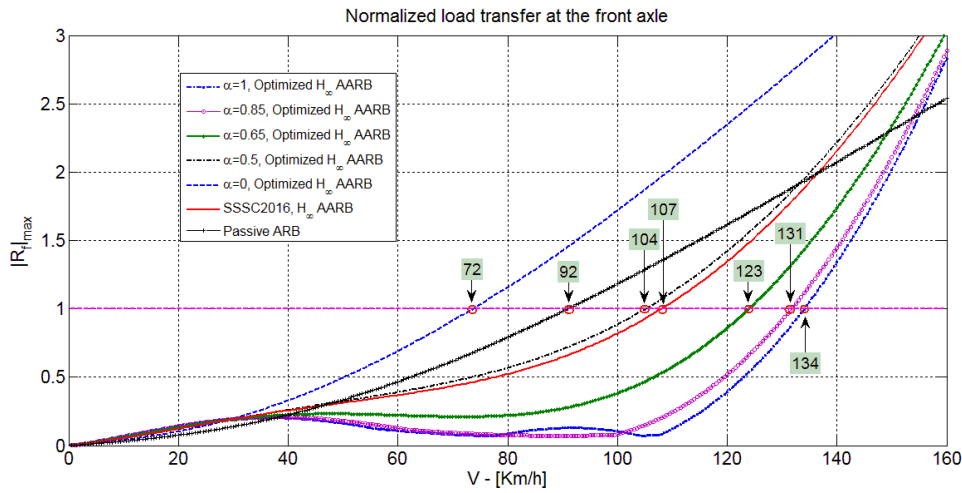

Figure. 9 Effect of the forward velocity on the normalized load transfer: front axle R_f .

Considering Fig 10, the maximum absolute value of the normalized load transfers at the rear axle reaches the limit “1” in the case of $\alpha = [1; 0.85; 0.65; 0.5]$ where the forward velocities are respectively 130 , 125 , 112 , 97 Km/h. Note that in the previous paper [18], we got 104 Km/h for the forward velocity. In fact, the forward velocities of heavy vehicles are often considered up around 100 Km/h, so that choosing α between 1 and 0.65 is convenient.

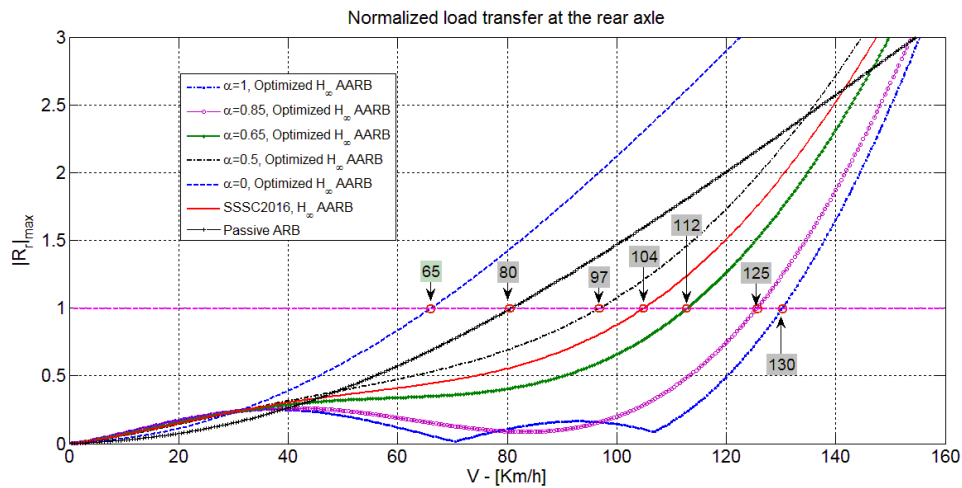

Figure. 10 Effect of the forward velocity on the normalized load transfer: rear axle R_r .

7. CONCLUSIONS

In this paper, a weighting function optimization procedure using GAs for H_∞ active anti-roll bar control on single unit heavy vehicle has been proposed. The conflicting objectives between the normalized load transfers and generated torques are handled using only one high level parameter, which is a great advantage to solve the multi-objective control problem. The simulation results in frequency and time domains have shown the efficiency of GAs in finding a suitable controller to satisfy the desired performance objectives.

Even if other structures for the weighting functions could be used, the ones used in this paper are shown to be simple enough while being efficient to solve the problem. For future works, the comparison with an LPV controller (scheduled by the forward vehicle velocity) will be of interest.

8. REFERENCES

- [1] **Alfaro-Cid, E., McGookin, E.W., and Murray-Smith, D.J.** Optimisation of the weighting functions of an H_∞ controller using genetic algorithms and structured genetic algorithms. *International Journal of Systems Science*, 2008. (p.335–347).
- [2] **Boada, M., Boada, B., Quesada, A., Gaucha, A., and Daz, V.** Active roll control using reinforcement learning for a single unit heavy vehicle. In *12th IFToMM World Congress*. Besancon, France, 2007.
- [3] **Davis, L.D.** *Handbook of genetic algorithms*. Van Nostrand Reinhold, 1991.
- [4] **Do, A.L.; B., Soualmi; Lozoya-Santos, Jesus; Sename, O.; Dugard, L.; Ramirez-Mendoza, R.** Optimization of weighting function selection for H_∞ control of semi-active suspensions, 12th Mini conference on vehicle system dynamics, identification and anomalies (VSDIA 2010). Budapest, Hungary, 2010.
- [5] **Gaspar, P., Bokor, J., and Szaszi, I.** The design of a combined control structure to prevent the rollover of heavy vehicles. *European Journal of Control*, 2004. (p.148–162).
- [6] **Gaspar, P., Bokor, J., and Szaszi, I.** Reconfigurable control structure to prevent the rollover of heavy vehicles. *Control Engineering Practice*, 2005a. (p.699–711).
- [7] **Gaspar, P., Szabo, Z., and Bokor, J.** Prediction based combined control to prevent the rollover of heavy vehicles. In *Proceedings of the 13th Mediterranean Conference on Control and Automation*. Limassol, Cyprus, 2005b.
- [8] **Goldberg, D.** *Genetic Algorithms in Searching Optimisation and Machine Learning*. Addison-Wesley Longman, 1989.
- [9] Holland, H.J. (1975). *Adaptation in natural and artificial systems, an introductory analysis with application to biology, control and artificial intelligence*. Ann Arbor, The university of Michigan Press.
- [10] **Kitsios, I. and Pimenides, T.** H_∞ controller design for a distillation column using genetic algorithms. *Mathematics and Computers in Simulation*, 2002.

- [11] **Miller, B.L., Miller, B.L., Goldberg, D.E., and Goldberg, D.E.** Genetic algorithms, tournament selection, and the effects of noise. *Complex Systems*, 1995. (p.193–212).
- [12] **Sampson, D. and Cebon, D.** An investigation of roll control system design for articulated heavy vehicles. In 4th International symposium on Advanced Vehicle Control, AVEC1998. Nagoya, Japan, 1998.
- [13] **Sampson, D. and Cebon, D.** Achievable roll stability of heavy road vehicles. In *Proceedings of the Institution of Mechanical Engineers, Part D: Journal of Automobile Engineering*, volume 217, United Kingdom, 2002.
- [14] **Sampson, D. and Cebon, D.** Active roll control of single unit heavy road vehicles. *Vehicle System Dynamics: International Journal of Vehicle Mechanics and Mobility*, 40(4), 2003. (p.229–270).
- [15] **Scherer, C. and Weiland, S.** *Linear matrix inequalities in control*, University Lecture, 2005.
- [16] **Skogestad, S. and Postlethwaite, I.** *Multivariable Feedback Control*. John Wiley & Sons, 2 edition, 2001.
- [17] **Vu, V.T., Sename, O., Dugard, L., and Gaspar, P.** Active anti-roll bar control using electronic servo-valve hydraulic damper on single unit heavy vehicle. In *IFAC Symposium on Advances in Automotive Control - 8th AAC 2016*, Sweden, 2016.
- [18] **Vu, V.T., Sename, O., Dugard, L., and Gaspar, P.** H_∞ active anti-roll bar control to prevent rollover of heavy vehicles: a robustness analysis. In *IFAC Symposium on System Structure and Control - 6th SSSC 2016*, Turkey, 2016.