



HAL
open science

Human expert supervised selection of time-frequency intervals in EEG signals for brain–computer interfacing

Alban Duprès, François Cabestaing, José Rouillard

► **To cite this version:**

Alban Duprès, François Cabestaing, José Rouillard. Human expert supervised selection of time-frequency intervals in EEG signals for brain–computer interfacing. EUSIPCO, Aug 2016, Budapest, Hungary. hal-01361793

HAL Id: hal-01361793

<https://hal.science/hal-01361793v1>

Submitted on 12 Sep 2016

HAL is a multi-disciplinary open access archive for the deposit and dissemination of scientific research documents, whether they are published or not. The documents may come from teaching and research institutions in France or abroad, or from public or private research centers.

L'archive ouverte pluridisciplinaire **HAL**, est destinée au dépôt et à la diffusion de documents scientifiques de niveau recherche, publiés ou non, émanant des établissements d'enseignement et de recherche français ou étrangers, des laboratoires publics ou privés.

HUMAN EXPERT SUPERVISED SELECTION OF TIME-FREQUENCY INTERVALS IN EEG SIGNALS FOR BRAIN-COMPUTER INTERFACING

Alban Duprès, François Cabestaing, José Rouillard

Univ. Lille, CNRS, Centrale Lille, UMR 9189 - CRISTAL

Centre de Recherche en Informatique Signal et Automatique de Lille, F-59000 Lille, France

{firstname.lastname@univ-lille1.fr}

Abstract—In the context of brain-computer interfacing based on motor imagery, we propose a method allowing a human expert to supervise the selection of user-specific time-frequency features computed from EEG signals. Indeed, in the current state of BCI research, there is always at least one expert involved in the first stages of any experimentation. On one hand, such experts really appreciate keeping a certain level of control on the tuning of user-specific parameters. On the other hand, we will show that their knowledge is extremely valuable for selecting a sparse set of significant time-frequency features. The expert selects these features through a visual analysis of curves highlighting differences between electroencephalographic activities recorded during the execution of various motor imagery tasks. We compare our method to the basic common spatial patterns approach and to two fully-automatic feature extraction methods, using dataset 2A of BCI competition IV. Our method (*mean accuracy* $m = 83.71 \pm 14.6$ *std*) outperforms the best competing method ($m = 79.48 \pm 12.41$ *std*) for 6 of the 9 subjects.

Index Terms—brain-computer interface, EEG signal processing, sparse feature set, feature selection, human expertise.

I. INTRODUCTION

Brain-computer interfaces (BCI) are devices that enable users to control effectors using only their cerebral activity. For now, non-invasive BCI have mainly been used to restore a communication channel between a severely disabled user and a computer, letting him/her recover a partial autonomy. In the so-called *active BCI* paradigms, users consciously control their mental activity at their own pace and independently from external events [1]. Motor imagery (MI), i.e. imagination of a specific motor action, is the most commonly used mental task in active BCIs. In this context, it is crucial to define appropriate features, computed from EEG signals, allowing the BCI to distinguish between different MI tasks performed by the user.

During MI, very specific neurophysiological patterns are elicited in electroencephalographic (EEG) signals, such as event-related desynchronisations (ERD) and event-related synchronisations (ERS). ERD and ERS are characterized respectively by a decrease of EEG power during MI and an increase of EEG power at the end of MI [2]. ERD and ERS

are known to appear mainly in EEG signals recorded over the motor cortex with a spatial distribution that depends on the MI task, following the cortical motor homunculus [3]. EEG frequency bands in which ERD and ERS can be detected during MI correspond to μ (7 – 13 Hz) and β (13 – 25 Hz) rhythms. Nevertheless, it is well known that the most relevant frequency bands and spatial locations are variable over subjects and MI tasks [4].

In order to facilitate the discrimination of MI tasks, the EEG signal processing pipeline typically includes a spatial filtering stage. CSP (Common Spatial Patterns) is the most widely used linear spatial filtering approach involving user-specific parameters [5]. A user-tuned CSP filter increases the variance of filtered EEG signals for one specific MI task while minimising their variance for other MI tasks or for non MI-related mental states. The actual discriminative performance of CSP filters depends on the frequency bands in which the signals are processed and on the time interval during which signal power is determined. For instance, CSP spatial filters computed on raw EEG signals or on EEG signals filtered in inappropriate frequency bands yield poor classification performance.

To solve this problem, several approaches have been described in the literature. Some researchers have proposed to keep a wide frequency range, i.e. encompassing μ and β rhythms and therefore valid for any user, and to improve the spatial filtering stage. For example [6] has compared several techniques for determining regularized versions of CSP, showing that spatial filtering can be significantly improved compared to basic CSP. Other researchers have proposed to select user-specific frequency bands in which ERD/ERS detection is more effective. For example, [4] implements multiple band-pass frequency filters and computes a specific CSP for each frequency band. Then, a feature selection algorithm keeps the most relevant frequency/CSP features for a given user.

However, all these techniques include a fully automatic feature selection stage, which implies defining empirically several meta-parameters, such as the number of features. But they do not specify the *sparsity* of the feature space by taking into account some *a priori* neurophysiological knowledge during this feature selection stage. Studies have shown that sparsity of the feature space allows for good classification performance because the BCI is less sensi-

tive to covariate shifts in EEG signals. For instance, Raza *et al.* have proposed to increase the sparsity using either forward-addition or backward-elimination of features in the space [7]. However, no detailed neurophysiological-based analysis of the ERD/ERS patterns is performed in order to select the most appropriate frequency intervals, spatial locations and time intervals in which the EEG signals should be analysed.

In this paper, we describe a technique in which a human expert selects a small number of time-frequency features during a first stage. Obviously, the expert does not examine the raw EEG signals to make his/her decision, which would require a very high level of expertise, but a set of curves plotted using samples of time-frequency processed EEG signals. Then, in a second stage, a CSP filter is determined for each retained time-frequency feature. This approach yields a sparse feature space, whose sparsity is controlled by a human expert and not by blindly setting the values of a few meta-parameters. We will also see that this approach enables us to gather detailed informations about the neurophysiological patterns of a given user during MI, and therefore better understand his/her performance.

II. METHOD

Since our method is supervised, the signal processing pipelines are slightly different for the training and the online processing modes. In the training mode, which aims at selecting features and adapting parameters, a set of labelled EEG trials is analysed. The BCI paradigm used for building this training set must be cue-based in the sense that the user is told when to start and when to stop imagining two or more different motions. In the online processing mode, the paradigm is not necessarily cue-based and the user can freely perform any of these MI tasks when he/she wants to.

Figure 1 illustrates the processing pipeline for the training mode. It is composed of four successive stages: spatial filtering, band-pass frequency filtering, power estimation,

and aggregation over trials. In the training mode, we wanted to use the same processing techniques and parameters for all the users. Thus, the surface Laplacian was selected for spatially filtering EEG signals since it allows spatial noise removal and source identification without requiring user-tuning [8]. Then, for highlighting user specificities in the frequency domain, like other authors we use a bank of band-pass filters encompassing the frequency bands of μ and β rhythms [7], [4]. For highlighting ERD/ERS in the signals, we compute their log-variance — equivalent to their power — in a sliding window of fixed duration. Finally, for getting a data representation easily understandable by the human expert, we compute the average and standard deviation, over all trials of each MI task, of signal power at every instant.

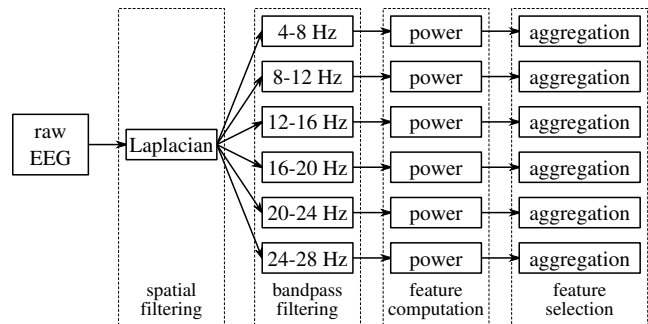

Figure 1: Processing pipeline for the training mode.

Indeed, the aim of the proposed method is to help the human expert to analyse neurophysiological time-frequency patterns related to MI tasks. For each MI task, he/she is asked to review a set of curves, one for each frequency band, showing the time-course of a specific signal known to be correlated to this MI. In order to clearly exhibit differences between the analysed MI task and other MI tasks, an additional baseline curve is shown to the expert for each frequency band. This baseline curve is computed

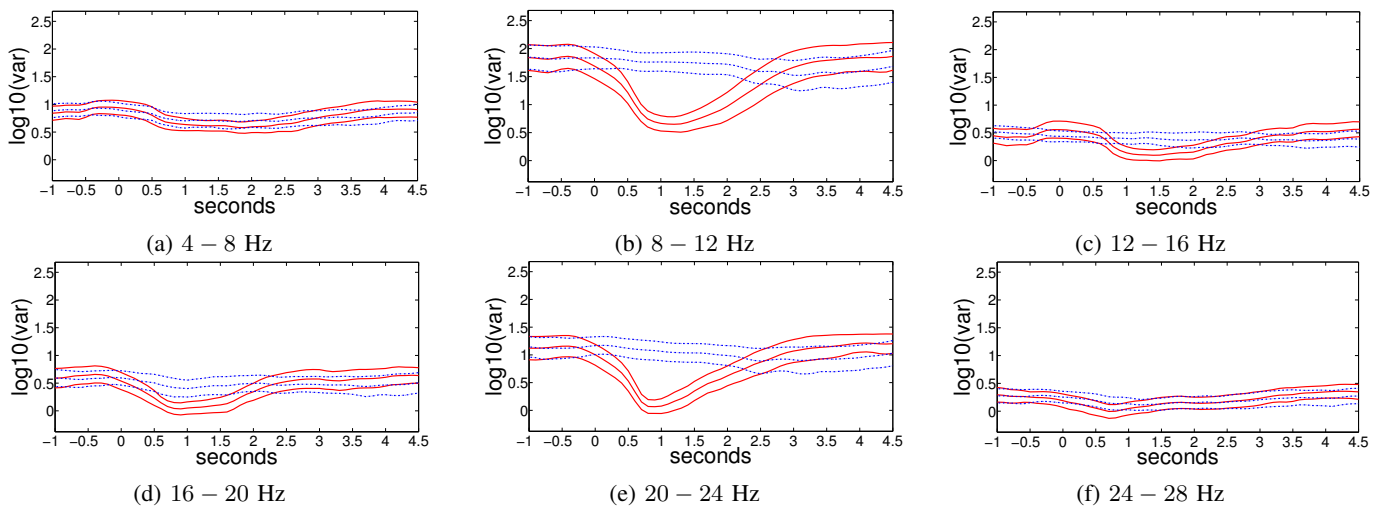

Figure 2: Set of curves for expert review of left hand motor imagery, electrode C4

by averaging values of the signal under consideration for all the trials corresponding to other MI tasks, i.e. following a one-versus-rest strategy.

For example, figure 2 shows the first set of six curves, one for each frequency band, displayed for review by the expert in order to tune a BCI based on left hand vs. right hand MI. The EEG signal recorded at location C4 over the right sensorimotor cortex is known to exhibit clear ERD when the user performs MI of the left hand. For this MI task, the curve of interest in each frequency band (solid red lines in figure 2) is the time-course of average power of this signal over all corresponding trials, after spatial noise removal by a Laplacian filter, in a time window starting one second before MI onset and ending one second and half after MI offset. Baseline curve in each frequency band (blue dotted lines in figure 2) is the average power of the same signal computed over all trials that do not correspond to the MI task under review. To display the statistical significance of signal variations, two additional curves are plotted around each curve at plus and minus half standard deviation.

A visual analysis of these curves enables the expert to select several time-frequency intervals that best discriminate this particular MI task from others. The expert pays attention to band-passed signals that highlight neurophysiological patterns related to a MI task, such as ERD or ERS patterns. Neurophysiological knowledge of a human expert is useful to visually identify such patterns, which have different frequency and temporal distribution over subjects. For example, two time-frequency intervals $[0 - 2.5 \text{ s}, 8 - 12 \text{ Hz}]$ and $[0 - 2.5 \text{ s}, 20 - 24 \text{ Hz}]$ can be selected as the best candidates to discriminate the two MI. After this, CSP filters are computed using epochs of all EEG signals in each of these time-frequency intervals, in order to optimise spatial filtering for this user compared to the non-adaptive Laplacian. Three pairs of CSP filters are kept for each time-frequency interval.

For the online mode, the processing pipeline includes four successive stages, as illustrated in figure 3. EEG signals are filtered in the spatial and frequency domains by CSP/band-pass pairs determined during the training mode. Then, the log-variances of filtered signals are computed over time intervals that were considered as most discriminant for each frequency by the expert, yielding a small number of features. Finally, the signal epoch is analysed by a LDA (Linear Discriminant Analysis) classifier. This processing pipeline can be performed over sliding overlapped time windows when the paradigm is not cue-based.

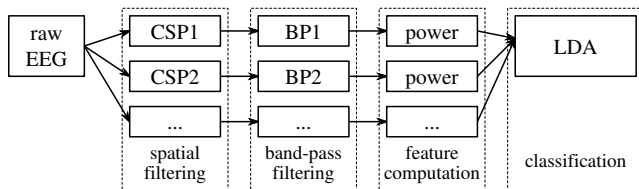

Figure 3: Processing pipeline for the online mode.

When the BCI paradigm involves more than two MI tasks, we implement a processing pipeline for each one.

Since the features are determined considering a one-versus-rest strategy, we follow the same approach for classifying signal epochs. Each LDA classifier outputs both a class and a confidence score, for instance the distance between the feature vector and the separating hyperplane. A standard voting procedure is used to determine the most appropriate class according to all outputs.

We also allow the expert to compare different sets of features, by excluding time-frequency intervals that were initially selected or including other intervals. To compare the efficiency of these various sets, the system evaluates the correct classification rate that each of them yields when applied on the training set of EEG signals. However, the expert can decide to keep a smaller set of features even with a slightly lower classification rate, if he/she considers that it is probably more robust to deal with covariate shifts in signals.

III. RESULTS AND COMPARISON

In this paper, our method is evaluated on EEG signals freely available in data set 2A of BCI competition IV, which has been widely used for comparison purposes [9]. This data set comprises raw EEG data recorded by 22 electrodes from 9 subjects. Subjects were asked to perform left hand, right hand, feet, and tongue MI. All MI tasks were performed during four seconds just after presentation of a cue. Each user performed two sessions on different days in order to obtain a training data set and an evaluation data set.

Only data recorded during left hand and right hand MI were used in the evaluation, in order to compare our method with those described in [6] and [7]. EEG signals recorded at locations C3 and C4 were spatially filtered by a Laplacian, yielding two signals of interest for further processing, one for each MI: the signal derived from spatial filtering of C3 (resp. C4) is known to exhibit ERD when the user performs right (resp. left) hand motor imagery. These signals were filtered by two banks of six band-pass frequency filters (5th order Butterworth), yielding twelve signals of interest. Finally, their log-variance was computed, time-averaged over a sliding window, and aggregated to determine time-courses of averages and standard deviations over trials. A sliding window of one second length allows to keep a good temporal resolution and to highlight ERD/ERS patterns by smoothing the signal power.

Then, the expert reviewed the curves plotted for each MI and each frequency band in order to retain time-frequency intervals that he considered as the most discriminant between left and right hand MI. For instance, curves displayed in figure 2 correspond to the signals of the training set for subject 9, that were reviewed by the expert. CSP filters were then determined for each time-frequency interval, LDA classifiers trained, and correct classifications scores computed for data of the training set. These scores, although obtained on the training data, could be used by the expert to add/remove time-frequency intervals by considering a trade-off between performance and sparsity.

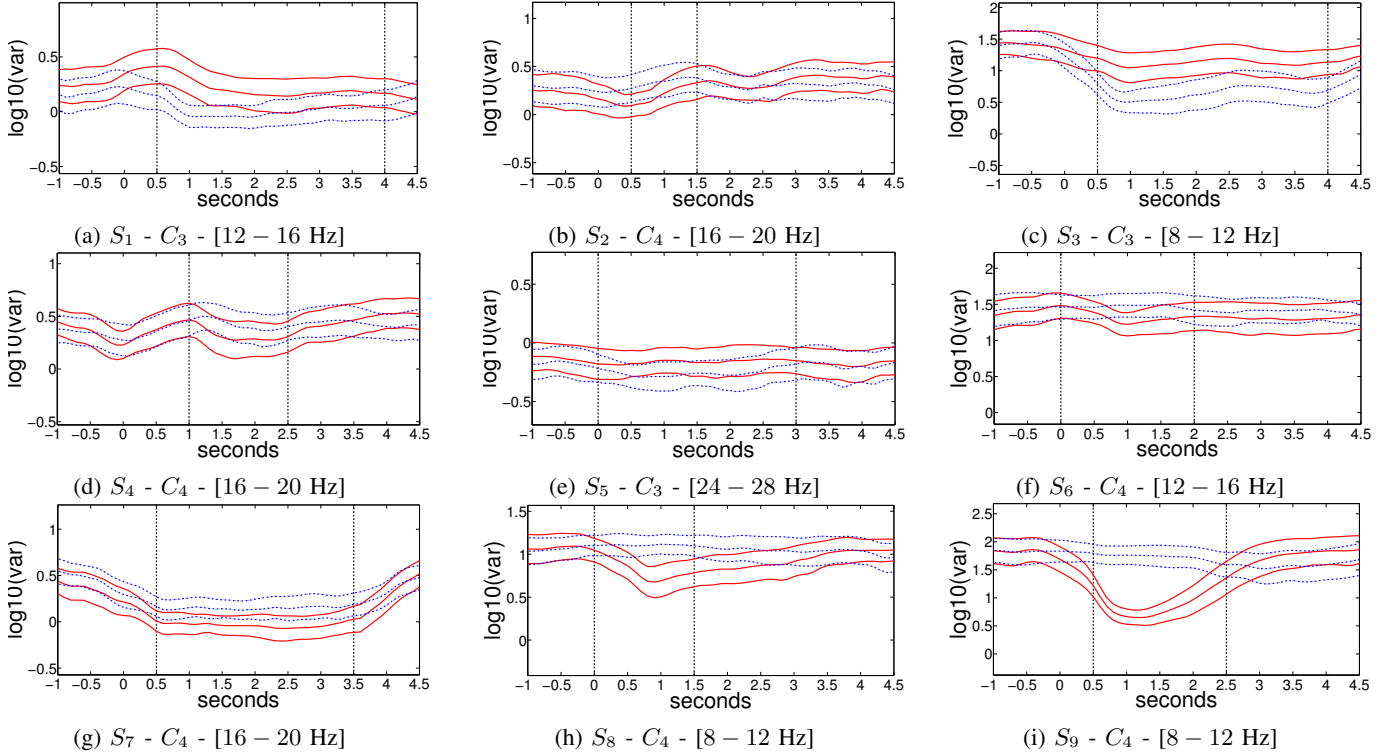

Figure 4: First time-frequency feature for each subject, the vertical black dashed lines indicate the time interval

For each subject, figure 4 shows the first time-frequency interval that our expert considered as the most discriminant between left (red solid lines) and right (blue dashed lines) hand MI. The vertical black dashed lines indicate boundaries of the selected time interval in each frequency band. One can observe that differences between the two MI tasks are more visible in the processed EEG for subjects 1, 3, 7, 8, and 9 than for other subjects. Table 1 indicates the sets of time-frequency intervals that were finally retained by our expert.

Subject	Time-frequency intervals $[t_1 - t_2 (s); f_1 - f_2 (Hz)]$
1	$[0.5 - 3.5; 8 - 12]$, $[0.5 - 4; 12 - 16]$, $[0.5 - 1.5; 20 - 24]$, $[0.5 - 2.5; 24 - 28]$
2	$[0.5 - 1.5; 12 - 16]$, $[0.5 - 1.5; 16 - 20]$
3	$[0.5 - 4; 8 - 12]$
4	$[0 - 1; 8 - 12]$, $[1 - 2.5; 16 - 20]$, $[0.5 - 2; 24 - 28]$
5	$[0 - 3; 4 - 8]$, $[0 - 1.7; 20 - 24]$, $[0 - 3; 24 - 28]$
6	$[0 - 1.5; 8 - 12]$, $[0 - 2; 12 - 16]$, $[0.5 - 2; 24 - 28]$
7	$[0 - 4; 4 - 8]$, $[0.5 - 4; 8 - 12]$, $[0.5 - 3.5; 16 - 20]$
8	$[0 - 1.5; 8 - 12]$, $[1 - 3; 12 - 16]$, $[0.5 - 3; 16 - 20]$, $[0.5 - 2.5; 20 - 24]$
9	$[0.5 - 2.5; 8 - 12]$

TABLE 1: Time-frequency features for each subject

Using this set of time-frequency features, and the online processing pipeline of figure 3, our method was compared to: 1) a standard CSP; 2) the weighted Tikhonov regularized CSP (WTRCSP) presented in [6]; 3) the backward-elimination (BE) method described in [7]. The basic CSP and the WTRCSP, which is the best regularized CSP algo-

rithm according to [6], are computed on a wide frequency range from 8 to 30 Hz and a time interval between 0.5 and 2.5 s after the cue. However the BE method computes CSP filters on user-specific frequency bands and a time interval between 0 and 3 s after the cue.

Table 2 shows the classification accuracies (in %) for each subject and each processing method. Methods are assessed on the evaluation data set, only mean and standard deviation are used for quantified and detailed analysis of results. The highest classification score for each subject is indicated in bold font. Our method (mean accuracy $m = 83.71 \pm 14.6 std$) outperforms the other methods for 5 of the 9 subjects. The performance of our method is worse for subjects 2, 5, and 9 but equal for subject 3. Our method is mainly profitable for subjects 4 and 7 for whom the accuracy is increased respectively by 9 and 15 percentage points compared to the best competing method. One can verify that methods which select user-specific frequency intervals, such as our method (mean $m = 83.71$) and the BE ($m = 79.43$) method, obtained better results than a basic CSP ($m = 78.01$) and a WTRCSP ($m = 78.47$) both computed on a wide frequency range.

IV. DISCUSSION

In Figure 4, according to the spatial location and the MI under review, we can observe for all subjects a decrease, even weak, of the EEG power recorded over the contralateral motor cortex. ERD patterns are present at location C4

Subject	basic CSP	WTRCSP	BE	Our method
1	88.89	88.89	90.28	92.36
2	51.39	54.86	63.19	61.11
3	96.53	96.53	93.75	96.53
4	70.14	70.14	70.14	79.17
5	54.86	65.97	72.92	62.5
6	71.53	61.81	65.97	75.69
7	81.25	81.25	75	96.53
8	93.75	95.83	91.67	97.22
9	93.75	90.97	92.36	92.36
Mean	78.01	78.47	79.48	83.71
Std	14.6	15.65	12.41	17.01

TABLE 2: Classification scores for each subject.

(resp. C3) during left (resp. right) hand MI. Simultaneously, the EEG signal power from the other MI recorded on the ipsi-lateral side remains stable, except for subject 7. Indeed for this subject ERD patterns are present for both MI over the motor cortex of the same hemisphere (see Figure 4g). However, ERD recorded at location C4 is more pronounced for the left hand (contra-lateral hemisphere) than for the right hand (ipsi-lateral hemisphere) MI. This difference of spatial distribution between ERD patterns of each MI is essential to allow the BCI to distinguish MI tasks.

According to Figure 4, the spectral and temporal distribution of ERD patterns are variable over subjects, supporting the fact that time-frequency features must be tuned for each user. Actually, ERD of subjects 3, 8, and 9 are more localised on the α rhythm while ERD of subjects 1, 2, 4, 5, 6, and 7 are more pronounced on the β rhythm. Concerning the temporal distribution, the time-course (onset/offset) of ERD show different aspects for each subject.

Table 2 shows strong classification accuracies ($> 90\%$), with our method, for subjects 1, 3, 7, 8, and 9. These performances can be partly explained by analysing their neurophysiological patterns elicited during MI, as shown in Figure 4. The curves show a substantial difference between EEG power of both MI compared to those plotted for the other subjects. Therefore we expect that better is the difference between EEG power of various MI, better the BCI will be able to distinguish the different mental tasks performed by the user. Results of our method, in Table 2, are promising for subjects 4 and 7. For subject 4 the classification accuracy changes from 70.14% to 79.17%. According to [10] 70% is the threshold to control correctly a BCI. By outperforming this threshold, subject 4 will be able to better control a BCI, improving his motivation. Therefore we expect that the learning between human and machine will be reinforced. The result of subject 7 is improved up to 96.53% which is an almost perfect classification accuracy. In that case we expect that subject 7 will control the BCI without difficulties.

According to Table 2 the selection of user-specific frequency bands, as in our method and the BE algorithm, yields to better performance compared to a large frequency range as used for the basic CSP and the regularized CSP. This result confirms the literature, assuming that the performance of CSP filters depends on frequency bands on which the signals are processed. More over, the use of appropriate time

intervals to compute CSP filters affect their performance, partly explaining the difference of classification accuracy between our method and the BE algorithm which uses a fix time interval. Therefore we expect by selecting time intervals where ERD occur, as illustrated in Figure 4, to better discriminate MI tasks.

V. CONCLUSION

We have proposed an easy to implement method in order to select the time-frequency intervals that best discriminate different classes in the context of MI-based BCI. The selection of time-frequency intervals is specific to each subject and is performed offline, using a set of pre-recorded signals. It is supervised by a human expert who reviews a set of curves determined for each MI task through a time-frequency analysis of the recorded EEG signals. The results of our study confirm the fact that a correct selection of time-frequency intervals impacts the performance of CSP, as mentioned in the literature. Moreover our method gathers detailed informations about the specific neurophysiological patterns appearing in EEG signals when the users performs MI. It enables a better understanding of the difference in classification accuracy between the subjects. We are currently developing a user-friendly software interface that will allow an easier selection of time-frequency intervals by the expert, as well as a visual validation of spatial patterns determined using the training set.

REFERENCES

- [1] T. O. Zander, C. Kothe, S. Welke, and R. M., "Enhancing human-machine systems with secondary input from passive brain-computer interfaces," in *4th Int. BCI Workshop*, Graz, Austria, 2008.
- [2] G. Pfurtscheller and F. H. L. da Silva, "Event-related EEG/MEG synchronization and desynchronization: basic principles," *Clinical Neurophysiology*, vol. 110, no. 11, pp. 1842–1857, Nov. 1999.
- [3] B. Blankertz, R. Tomioka, S. Lemm, M. Kawanabe, and K.-R. Muller, "Optimizing spatial filters for robust EEG single-trial analysis," *Signal Processing Magazine, IEEE*, vol. 25, no. 1, pp. 41–56, 2008.
- [4] K. K. Ang, Z. Y. Chin, H. Zhang, and C. Guan, "Filter bank common spatial pattern (FBCSP) in brain-computer interface," in *IEEE Int. Joint Conf. on Neural Networks*. IEEE, 2008, pp. 2390–2397.
- [5] H. Ramoser, J. Muller-Gerking, and G. Pfurtscheller, "Optimal spatial filtering of single trial EEG during imagined hand movement," *Rehabilitation Eng., IEEE Trans. on*, vol. 8, no. 4, pp. 441–446, 2000.
- [6] F. Lotte and C. Guan, "Regularizing common spatial patterns to improve BCI designs: unified theory and new algorithms," *IEEE Trans. on Biomedical Engineering*, vol. 58, no. 2, pp. 355–362, 2011.
- [7] H. Raza, H. Cecotti, and G. Prasad, "Optimising frequency band selection with forward-addition and backward-elimination algorithms in EEG-based brain-computer interfaces," in *International Joint Conference on Neural Networks*, 2015, pp. 1–7.
- [8] D. J. McFarland, "The advantages of the surface Laplacian in brain-computer interface research," *Int. Journal of Psy.*, vol. 93, no. 3, pp. 271–276, 2015.
- [9] C. Brunner, R. Leeb, G. Müller-Putz, A. Schlögl, and G. Pfurtscheller, "BCI competition 2008–graz data set A," *Lab. of Brain-Computer Interfaces, Graz Uni. of Technology*, pp. 136–142, 2008.
- [10] A. Kübler, N. Neumann, B. Wilhelm, T. Hinterberger, and N. Birbaumer, "Predictability of brain-computer communication," *Journal of Psychophysiology*, vol. 18, no. 2/3, pp. 121–129, 2004.