



HAL
open science

Event-based visual guidance inspired by honeybees in a 3D tapered tunnel

Julien Serres, T Raharijaona, E Vanhoutte, F Ruffier

► **To cite this version:**

Julien Serres, T Raharijaona, E Vanhoutte, F Ruffier. Event-based visual guidance inspired by honeybees in a 3D tapered tunnel. Second International Conference on Event-Based Control, Communication and Signal Processing EBCCSP 2016, Jun 2016, Krakow, Poland, France. 10.1109/EBCCSP.2016.7605273 . hal-01332819

HAL Id: hal-01332819

<https://hal.science/hal-01332819>

Submitted on 16 Jun 2016

HAL is a multi-disciplinary open access archive for the deposit and dissemination of scientific research documents, whether they are published or not. The documents may come from teaching and research institutions in France or abroad, or from public or private research centers.

L'archive ouverte pluridisciplinaire **HAL**, est destinée au dépôt et à la diffusion de documents scientifiques de niveau recherche, publiés ou non, émanant des établissements d'enseignement et de recherche français ou étrangers, des laboratoires publics ou privés.

Event-based visual guidance inspired by honeybees in a 3D tapered tunnel

J. Serres¹, T. Raharijaona¹, E. Vanhoutte¹ and F. Ruffier¹

Abstract—In view of neuro-ethological findings on honeybees and our previously developed vision-based autopilot, in-silico experiments were performed in which a “simulated bee” was made to travel along a doubly tapering tunnel including for the first time event-based controllers. The “simulated bee” was equipped with:

- a minimalistic compound eye comprising 10 local motion sensors measuring the optic flow magnitude,
- two optic flow regulators updating the control signals whenever specific optic flow criteria changed,
- and three event-based controllers taking into account the error signals, each one in charge of its own translational dynamics.

A MORSE/Blender based simulator-engine delivered what each of 20 “simulated photoreceptors” saw in the tunnel lined with high resolution natural 2D images. The “simulated bee” managed to travel safely along the doubly tapering tunnel without requiring any speed or distance measurements, using only a Gibsonian point of view, by:

- concomitantly adjusting the side thrust, vertical lift and forward thrust whenever a change was detected on the optic flow-based signal errors,
- avoiding collisions with the surface of the doubly tapering tunnel and decreasing or increasing its speed, depending on the clutter rate perceived by motion sensors.

I. INTRODUCTION

Winged insects are able to navigate through unfamiliar environments without any need for sensory systems such as Global Positioning Systems (GPS) or Inertial Measurement Units (IMUs), or emissive proximity sensors such as ultrasonic or laser range finders, radar, or scanning Light Detecting And Ranging (LIDAR) sensors, using only the Optic Flow (OF) ([1]; [2]; [3]). Flying insects make use of the OF to jointly avoid lateral obstacles and control their speed ([4]; [5]), and to cruise and land ([6]; [4]; [7]). Electrophysiological studies on flies motion sensitive neurons have shown that OF detection is texture- and contrast-independent [8], and can be explained by a “time-of-travel” scheme ([9]; [10]; [11]; Fig. 6 in [12]), which differs from the Hassenstein-Reichardt model originally developed in 1956 [13]. The output of “time-of-travel”-based OF sensors can be only updated when a change in the optical contrast with time is detected. An asynchronous signal is therefore generated in the output of a “time-of-travel”-based OF sensor, which can be conveniently used in event-based control systems

[14]. Because of the slight delay in the camera read-out, event-based collision avoidance algorithms have been only developed so far under open loop conditions in slightly cluttered corridors, but they were expected to be ready for use in the near future in closed loop on-board robotic platforms ([15]; [16]). Event-based control systems have also been used for visual odometric purposes in the field of robotics [17].

In the present paper, we present for the first time an event-based version of the ALIS autopilot (ALIS stands for “AutopiLot using an Insect-based vision System”), which was originally designed with fixed-step digital controllers to perform tunnel-following tasks [18]. The ALIS autopilot is based on the principle of dual OF regulators ([18], [5], [7]) using ventral, dorsal, and lateral OFs. In section 2, the set-up of the simulation and the simulated agent mimicking a honeybee equipped with a minimalistic visual system including only 10 local OF measurements are described. In section 3, we describe the trajectories of the simulated agent fitted with the event-based ALIS autopilot in a doubly tapering tunnel (with a tapering angle of 7° in both planes). The results of the simulations performed show that the event-based ALIS autopilot generates a small number of events making the “simulated bee” travel along the tapered tunnel, thus greatly decreasing the number of control signal computations required.

II. SIMULATION SET-UP

In-silico experiments were carried out on two standard computers running: (i) a first one equipped with the MATLAB/Simulink[©] software program at a sampling rate of 1kHz for OF sensing purposes and feeding the event-based control systems, and (ii) a second one equipped with the MORSE software program (MORSE stands for “Modular OpenRobots Simulation Engine” [19], [20]) to simulate the visual interactions with the virtual 3D environment. The two computers were linked together by a TCP/IP protocol in which the maximum delay was limited to 3ms. The virtual 3D environment was built with the Blender software program [21]. The four surfaces of the tunnel were lined with high resolution photographs of natural panoramic scenes [22]. The 20 scalar photoreceptor signals were transmitted via TCP/IP to a second computer processing the 10 local optic flow computations, the 3 event-based controllers and the 3 translational dynamics of the “simulated bee” using the Matlab/Simulink software program. The Matlab/Simulink program then sent the 3D position (X, Y, Z) of the “simulated bee” back to the MORSE simulator.

This work was supported partly by CNRS (Life Science; Information Science; Engineering Science and Technology), Aix-Marseille University and the French Defence Agency (DGA).

¹J. Serres, T. Raharijaona, E. Vanhoutte and F. Ruffier are with Aix-Marseille Université, CNRS, ISM UMR 7287, 13288 Marseille, France julien.serres@univ-amu.fr

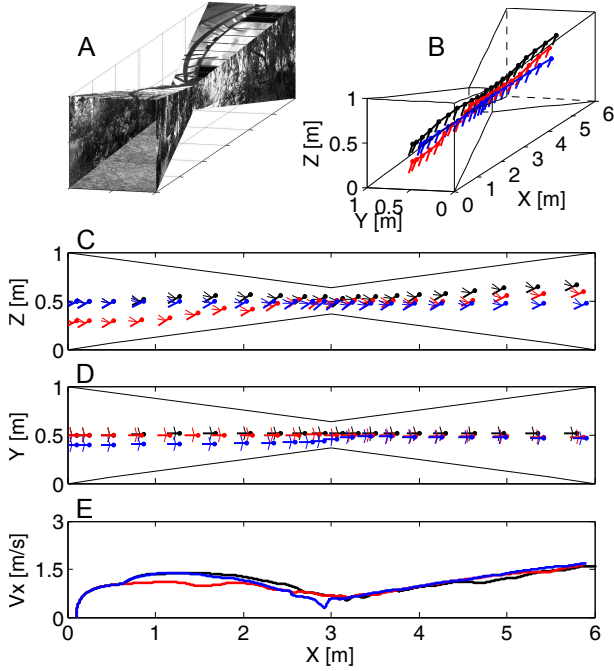

Fig. 1. (A) Perspective view of the doubly tapering tunnel, (B) Simulated bees 3D trajectories starting at the initial coordinates $x_0 = 0.1\text{m}$; $y_0 = 0.5\text{m}$; $z_0 = 0.5\text{m}$ (in black), $x_0 = 0.1\text{m}$; $y_0 = 0.4\text{m}$; $z_0 = 0.5\text{m}$ (in blue) and $x_0 = 0.1\text{m}$; $y_0 = 0.5\text{m}$; $z_0 = 0.3\text{m}$ (in red) plotted every 300ms, (C) Trajectories in the vertical plane (x,z), and in (D) in the horizontal plane (x,y), plotted every 300ms. (E) Forward speed V_x profiles.

A. Optic flow

The OF vector field perceived by a simulated agent depends in particular on the structure of the 3D environment ([1]; [2]; [3]). The OF can be defined by a vector field of the apparent motion of objects, surfaces, and edges in a visual scene generated by the relative motion between an agent and the scene. The OF field $\vec{\omega}$ (1) is a combination between two components: a translational $\vec{\omega}_T$ and a rotational OF $\vec{\omega}_R$ [3].

$$\vec{\omega} = \vec{\omega}_T + \vec{\omega}_R \quad (1)$$

It has been established that hymenopterans stabilize their gaze by compensating for any body rotations [23]. Since the simulated bee’s head is assumed to be stabilized along the tunnel axis, each OF sensor will receive a purely translational OF ($\vec{\omega}_R = \vec{0}$). The translational OF (expressed in rad/s) can be defined as follows:

$$\vec{\omega}_T = -\frac{\vec{V} - (\vec{V} \cdot \vec{d}) \cdot \vec{d}}{D} \quad (2)$$

where \vec{d} is a unit vector describing the viewing direction, \vec{V} is the translational velocity vector, and D is the distance from the object seen by an OF sensor.

B. Simulated flying agent

The behaviour of the “simulated bee” introduced into the in-silico experiments was based on findings which may explain how a flying honeybee controls its speed and avoids

obstacles ([6]; [4]; [5]); [7]). Each translational axis of the bee’s dynamic model was uncoupled, as occurs in a quadrotor. Each of the bee’s translational dynamics can be defined by a first order transfer function (see [18] for details) with a time constant of 0.22s [6]. Pitch angle, roll angle, and wing stroke amplitude were bounded on the basis of data previously published on bees [18]. In this indoor study, the simulated agent was not subjected to any wind. In addition, the agent’s rotational dynamics and the various mechanical couplings have been not considered in this work-in-progress paper yet.

The present agent was equipped with a set of 10 OF sensors: each of these sensors consisted of just two photoreceptors driving an Local Motion Sensor (LMS) based on a “time-of-travel” scheme [8]. The visual axes of the two adjacent photoreceptors were assumed to be separated by the angle $\Delta\phi$, and each photoreceptor’s angular sensitivity was assumed to be a Gaussoid function with an angular width at half height of $\Delta\rho = \Delta\phi = 4.2^\circ$. 6 OF sensors were located in the horizontal plane oriented at azimuthal angles φ of $\pm 45^\circ$, $\pm 90^\circ$, and $\pm 135^\circ$, and the other 4 were oriented in the vertical plane at elevation angles θ of $+45^\circ$, $\pm 90^\circ$ and -135° .

III. EVENT-BASED DISCRETE TIME CONTROLLERS

In this section, we describe how we tuned the event-based control approach introduced in [14] for OF regulation purposes. Three control input signals were computed, corresponding to the three uncoupled translational degrees of freedom on the surge (x), sway (y) and heave axes (z). We consider in this work as an “event”, an event-related condition based on the error signals. Lead controllers are introduced into the heave and sway control systems to improve their stability. The natural integrator that relates the simulated agent’s position to its speed makes both the heave and sway control systems reach a zero steady state error. However, a PI controller is introduced into the surge control system because OF is proportional to speed, but inversely proportional to distance (2). Consequently, we have to add an integral action to cancel the steady state error.

A. Event-based PI controller on the surge axis

A discrete time PI controller was designed. The modelling of the proportional part was quite straightforward, and the backward difference approximation method was used to model the integral part. The resulting code is:

```

% Inputs
ysp = u(1); % Optic flow SetPoint = 540 [deg/s]
y = u(2); % Optic flow Measurement
e = ysp - y;
% Update control signal
hact = hact + Ts; % Ts=1e-3s
if (abs(e-e_old)>elim) % elim = 1
    % Calculate control signal
    up = Kp*e;
    ui = ui + Ki*hact*e;
end
u = up + ui;
% Update
e_old=e;
y_old=y;
hact=0;

```

The event-based controller is tuned with the values $K_p = 20.10^{-3}$, $K_i = 6.10^{-2}$ and $T_s = 1\text{ms}$.

B. Event-based PD controllers on the sway and the heave axes

Two discrete time PD controllers were also designed to deal with the sway (y) and heave axes (z). Modelling the proportional part was quite straightforward, and the backward difference approximation method was used to model the derivative part. The following code was thus obtained for each controller:

```

\% Inputs
ysp = u(1); \% Optic flow SetPoint = 315 [deg/s]
y = u(2); \% Optic flow Measurement
sign = u(3);
e = ysp - y;
\% Update control signal
hact = hact + Ts; \% Ts=1e-3s
if (abs(e-e_old)>elim) \% elim = 1 \% N=100
    \% Calculate control signal
    up = sign*Kp*e;
    ud = Td/(N*hact + Td)*ud - Kp*Td*N/(N*hact + Td)*(y - y_old);
end
u = up + sign*ud;
\% Update
e_old=e;
y_old=y;
hact=0;

```

The event-based controllers on the sway axis were tuned with the values $K_p = 20.10^{-4}$, $T_d = 0.1\text{s}$, and on the heave axis, they were tuned with the values $K_p = 20.10^{-3}$, $T_d = 0.1\text{s}$. The input $sign$ was defined on the basis of Fig.2 adapted from [18]. The parameter $elim$ was chosen in order to significantly reduce the control updates, while making it possible to perform reference tracking of the OF set-points.

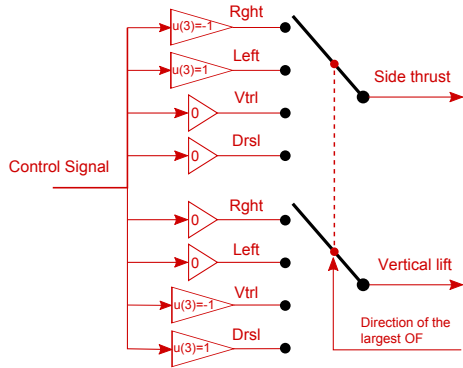

Fig. 2. The control direction selector automatically selects the tunnel surface to be followed (wall, ground or roof) by multiplying the control signal (the output from the Positioning controller) by a direction factor $u(3)$ that depends on the direction of the largest OF signal. Note that the sway and heave dynamics can be driven alternately, depending on which OF (side or vertical) is the largest at any given time. Adapted from [18].

IV. RESULTS

In Fig.1, the simulated environment was a doubly tapering tunnel 6m long, 1m wide, 1m high with a slope angle of 7° . Fig.1A gives a perspective view of the tunnel. The simulated bee entered the tunnel at zero speed, with the initial coordinates $x_0 = 0.1\text{m}$ and various couples/pairs of y_0 and z_0 (Fig.1B). Within the first 800ms, the simulated bee was

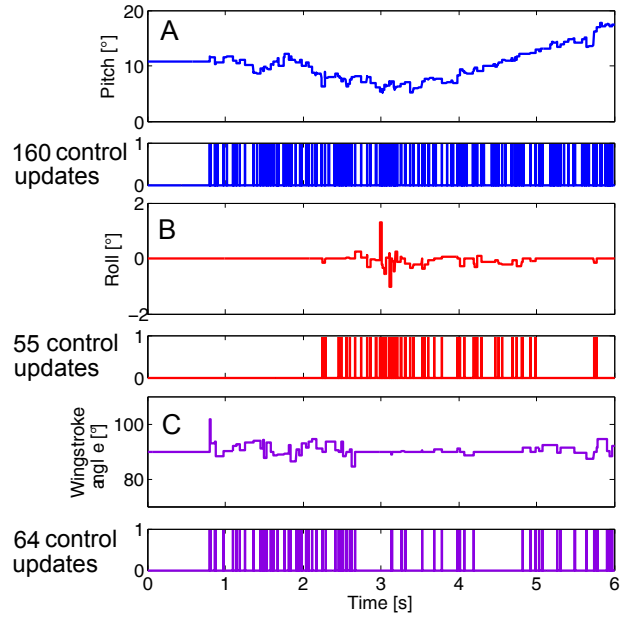

Fig. 3. Simulated control signals and control updates during a 3D trajectory starting at the initial coordinates $x_0 = 0.1\text{m}$; $y_0 = 0.5\text{m}$; $z_0 = 0.3\text{m}$

controlled in the open loop mode to enable all the sensors measure the OFs. From the time 800ms onwards, the OF was regulated in the closed loop mode via the event-based controllers. Fig.1C shows three trajectories in the vertical plane (x, z) and Fig.1D shows these trajectories in the horizontal plane (x, y), plotted every 300ms. The simulated bee can be seen to have gradually increased both its ground clearance (Fig.1C) and its right and left clearance (Fig.1D), while the forward speed (Fig.1E) increased automatically up to 1.5m/s.

Fig.3A gives the control input signal and the control updates on the surge axis with $x_0 = 0.1\text{m}$, $y_0 = 0.5\text{m}$ and $z_0 = 0.3\text{m}$. The control input signals are also plotted on the sway and heave axes in Fig.3A and 3B. It can be seen that the number of control updates is greatly reduced in comparison with fixed-step digital controllers. Fig.4A plots the OF with respect to the set-point of $540^\circ/\text{s}$ driving the surge dynamics. In Fig.4B, the OF is plotted with respect the set-point of $315^\circ/\text{s}$ driving the sway and heave dynamics. Both systems of OF regulation gave satisfactory results.

V. CONCLUSIONS

In this paper, we present results of work-in-progress on an event-based autopilot mimicking the direct Optic Flow (OF) feedback control loops which may occur in honeybees. Likewise, honeybees tiny brains contain smart OF sensors, called Velocity-Tuned motion-sensitive descending neurons (or VT neurons): these are spiking neurons which are sensitive to the OF [24]. Flies are also equipped with a sensory system based on Lobula Plate Tangential Cells (LPTC), which are also spiking neurons coding the local motion detection signals triggered inside the insects brain [25]: each spike can be taken to constitute an event occurring in the insects neuronal system. Our proposed event-based control system is currently

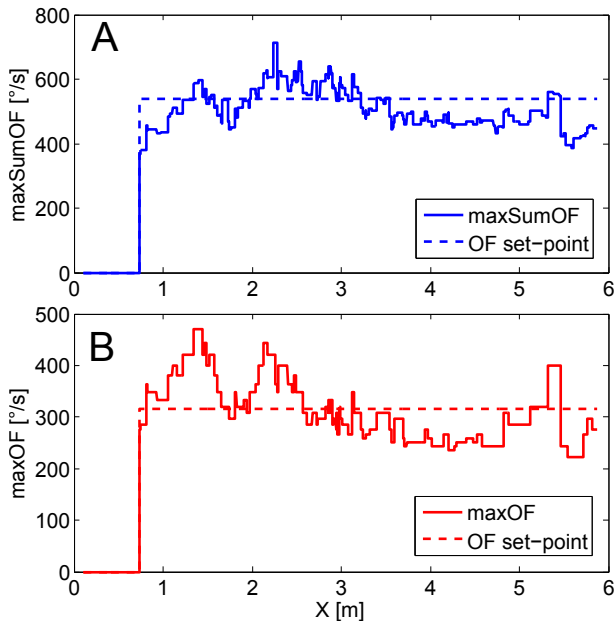

Fig. 4. Simulated systems of OF regulation in the case of a 3D trajectory starting at the initial coordinates $x_0 = 0.1\text{m}$; $y_0 = 0.5\text{m}$; $z_0 = 0.3\text{m}$ (A) Forward feedback signal determined by taking the largest sum of two diametrically opposed OF sensors (horizontal OF sensors, vertical OF sensors) (B) Positioning feedback signal determined by taking the largest output from the OF sensors (right OF sensors; left OF sensors, ventral OF sensors, dorsal OF sensors).

based on error signals, but in a near future it will be likely to become a major tool which can be used to understand more clearly how insects process the event-based visual information they receive in order to react appropriately: this information ranges from optical contrasts and local motion detection to self-induced wing movements generating the insects 3D movements in any tunnel configuration.

The results of the present in-silico experiments show that the OF-based regulatory strategy consisting in updating the control signals solely when visual contrasts are detected provides a suitable basis for traveling along an unknown tapered tunnel. It is now proposed to perform further studies involving a more sophisticated OF-based autopilot traveling along more complex tunnels, as well as to implement the event-based ALIS autopilot in the near future on-board a 380-g X4 MaG quadrotor [26].

ACKNOWLEDGMENT

We thank R. Brinkworth and D. O'Carroll (Adelaide Uni.) for kindly making their panoramic images available to us, and J. Blanc for improving the English manuscript.

REFERENCES

- [1] J. Gibson, *The perception of the visual world*. Boston: Houghton Mifflin, 1950.
- [2] K. Nakayama and J. Loomis, "Optical velocity patterns, velocity-sensitive neurons, and space perception: a hypothesis," *Perception*, vol. 3, no. 1, pp. 63–80, 1974.
- [3] J. J. Koenderink and A. J. van Doorn, "Facts on optic flow," *Biological cybernetics*, vol. 56, no. 4, pp. 247–254, 1987.
- [4] M. V. Srinivasan, "Honeybees as a model for the study of visually guided flight, navigation, and biologically inspired robotics," *Physiological Reviews*, vol. 91, no. 2, pp. 413–460, 2011.

- [5] F. L. Roubieu, J. R. Serres, F. Colonnier, N. Franceschini, S. Viollet, and F. Ruffier, "A biomimetic vision-based hovercraft accounts for bees complex behaviour in various corridors," *Bioinspiration & biomimetics*, vol. 9, no. 3, p. 036003, 2014.
- [6] N. Franceschini, F. Ruffier, and J. Serres, "A bio-inspired flying robot sheds light on insect piloting abilities," *Current Biology*, vol. 17(4), pp. 329–335, 2007.
- [7] F. Expert and F. Ruffier, "Flying over uneven moving terrain based on optic-flow cues without any need for reference frames or accelerometers," *Bioinspiration & biomimetics*, vol. 10, no. 2, p. 026003, 2015.
- [8] N. Franceschini, A. Riehle, and A. Le Nestour, "Directionally selective motion detection by insect neurons," in *Facets of vision*. Springer, 1989, pp. 360–390.
- [9] P. Lichtsteiner, C. Posch, and T. Delbruck, "A 128×128 120 db $15 \mu\text{s}$ latency asynchronous temporal contrast vision sensor," *Solid-State Circuits, IEEE Journal of*, vol. 43, no. 2, pp. 566–576, 2008.
- [10] R. Benosman, S.-H. Ieng, C. Clercq, C. Bartolozzi, and M. Srinivasan, "Asynchronous frameless event-based optical flow," *Neural Networks*, vol. 27, pp. 32–37, 2012.
- [11] G. Sabiron, P. Chavent, T. Raharijaona, P. Fabiani, and F. Ruffier, "Low-speed optic-flow sensor onboard an unmanned helicopter flying outside over fields," in *Robotics and Automation (ICRA), 2013 IEEE International Conference on*. IEEE, 2013, pp. 1742–1749.
- [12] D. Floreano, R. Pericet-Camara, S. Viollet, F. Ruffier, A. Brückner, R. Leitel, W. Buss, M. Menouni, F. Expert, R. Juston *et al.*, "Miniature curved artificial compound eyes," *Proceedings of the National Academy of Sciences*, vol. 110, no. 23, pp. 9267–9272, 2013.
- [13] B. Hassenstein and W. Reichardt, "Systemtheoretische analyse der zeit-, reihenfolgen- und vorzeichenbewertung bei der bewegungsperzeption des rüsselkäfers chlorophanus," *Zeitschrift für Naturforschung B*, vol. 11, no. 9–10, pp. 513–524, 1956.
- [14] S. Durand and N. Marchand, "Further results on event-based PID controller," in *Control Conference (ECC), 2009 European, Aug 2009*, pp. 1979–1984.
- [15] X. Clady, C. Clercq, S.-H. Ieng, F. Houseini, M. Randazzo, L. Natale, C. Bartolozzi, and R. Benosman, "Asynchronous visual event-based time-to-contact," *Neuromorphic Engineering Systems and Applications*, p. 51, 2015.
- [16] M. B. Milde, O. J. Bertrand, R. Benosman, M. Egelhaaf, and E. Chicca, "Bioinspired event-driven collision avoidance algorithm based on optic flow," in *Event-based Control, Communication, and Signal Processing (EBCCSP), 2015 International Conference on*. IEEE, 2015, pp. 1–7.
- [17] A. Censi and D. Scaramuzza, "Low-latency event-based visual odometry," in *Robotics and Automation (ICRA), 2014 IEEE International Conference on*. IEEE, 2014, pp. 703–710.
- [18] G. Portelli, J. Serres, F. Ruffier, and N. Franceschini, "Modelling honeybee visual guidance in a 3-D environment," *Journal of Physiology-Paris*, vol. 104, no. 1, pp. 27–39, 2010.
- [19] *Modular OpenRobots Simulation Engine*, 19 May 2015: MORSE release 1.3 under GNU GPLv2, <https://www.openrobots.org/wiki/morse/>.
- [20] G. Echeverria, N. Lassabe, A. Degroote, and S. Lemaignan, "Modular openrobots simulation engine: Morse," in *Proceedings of the IEEE ICRA, 2011*.
- [21] *Blender*, 15 Nov. 2015: Blender release 2.76 under GNU GPLv2, <https://www.blender.org/>.
- [22] R. S. Brinkworth and D. C. Carroll, "Biomimetic motion detection," in *Intelligent Sensors, Sensor Networks and Information, 2007. ISSNIP 2007. 3rd International Conference on*. IEEE, 2007, pp. 137–142.
- [23] S. Viollet and J. Zeil, "Feed-forward and visual feedback control of head roll orientation in wasps (*Polistes humilis*, *Vespa*, *Hymenoptera*)," *The Journal of experimental biology*, vol. 216, no. 7, pp. 1280–1291, 2013.
- [24] M. R. Ibbotson, "Evidence for velocity-tuned motion-sensitive descending neurons in the honeybee," *Proc R Soc of London B*, vol. 268, no. 1482, pp. 2195–2201, Nov 2001. [Online]. Available: <http://dx.doi.org/10.1098/rspb.2001.1770>
- [25] H. Krapp and R. Hengstenberg, "Estimation of self-motion by optic flow processing in single visual interneurons," *Nature*, vol. 384, pp. 463–466, 1996.
- [26] A. Manecy, N. Marchand, and S. Viollet, "RT-MaG: An open-source SIMULINK toolbox for linux-based real-time robotic applications," in *Robotics and Biomimetics (ROBIO), 2014 IEEE International Conference on*. IEEE, 2014, pp. 173–180.