



HAL
open science

Modified Navier-Stokes equations for the outflow boundary conditions in hemodynamics

Grégory Arbia, Irene Vignon-Clementel, Tainyen Y. Hsia, Jean-Frédéric
Gerbeau

► **To cite this version:**

Grégory Arbia, Irene Vignon-Clementel, Tainyen Y. Hsia, Jean-Frédéric Gerbeau. Modified Navier-Stokes equations for the outflow boundary conditions in hemodynamics. *European Journal of Mechanics - B/Fluids*, 2016, 60, pp.175-188. 10.1016/j.euromechflu.2016.06.001 . hal-01328501

HAL Id: hal-01328501

<https://hal.science/hal-01328501>

Submitted on 8 Jun 2016

HAL is a multi-disciplinary open access archive for the deposit and dissemination of scientific research documents, whether they are published or not. The documents may come from teaching and research institutions in France or abroad, or from public or private research centers.

L'archive ouverte pluridisciplinaire **HAL**, est destinée au dépôt et à la diffusion de documents scientifiques de niveau recherche, publiés ou non, émanant des établissements d'enseignement et de recherche français ou étrangers, des laboratoires publics ou privés.

1 Modified Navier-Stokes equations for the outflow boundary
2 conditions in hemodynamics*

3 G. Arbia^{a,b,*}, I.E. Vignon-Clementel^{a,b,*}, T.-Y. Hsia^c, J-F. Gerbeau^{a,b}, for the
4 Modeling of Congenital Hearts Alliance (MOCHA) Investigators

5 ^a*INRIA, Paris, France*

6 ^b*Sorbonne Universités, UPMC Univ Paris 6, Laboratoire Jacques-Louis Lions, Paris, France*

7 ^c*Centre for Cardiovascular Imaging, UCL Institute of Cardiovascular Science, and Great Ormond*
8 *Street Hospital for Children, NHS Foundation Trust, London, UK*

9 *Keywords:* Boundary conditions, Computational hemodynamics, Backflow
10 instabilities

*Authors contributed equally

*Accepted for publication in European Journal of Mechanics / B Fluids

11 **Abstract**

12 We present a new approach for the outflow boundary conditions of Navier-
13 Stokes equations in hemodynamics. We first describe some existing 3D-0D cou-
14 pling methods and highlight benefits and disadvantages of each of them. We then
15 introduce a new method that consists in adding a 3D artificial part where the
16 Navier-Stokes equations are modified to obtain an equivalent energy balance to
17 a standard coupling with a 3-element Windkessel model. We investigate theoret-
18 ically the stability of the system and compare it to previously introduced methods.
19 Finally we compare these coupling methods for numerical simulations of blood
20 flow in three patient-specific models, which represent different flow regimes in
21 the pulmonary and systemic circulations. The new method, especially in its hybrid
22 form, is a possible alternative to existing methods. It can be in particular convenient
23 in codes that do not allow users to implement non-standard boundary conditions.

24 **1. Introduction**

25 The three-dimensional Navier-Stokes simulation of blood flow in large vessels re-
26 quires inlet and outlet boundary conditions that represent hemodynamics at these
27 locations. However, in patient-specific settings, pressure or velocity are rarely clin-
28 ically measured exactly there, or they can be part of the desired output [43]. Thus,
29 boundary conditions are usually substituted for transmission conditions with re-
30 duced models of the rest of the circulation. This typically involves coupling to 1D
31 models (e.g. [8, 15, 33, 41]), or simple lumped parameter 0D models (e.g. [18,
32 37, 42, 44]) or closed loop lumped parameter 0D models (e.g. [3, 10, 25, 28, 30]).
33 This coupling methodology transfers in various forms pressure and flow rate be-
34 tween 3D and reduced models, for which there is a loss of information. Moreover,
35 reverse flow may occur in parts of or on entire coupling boundaries. This calls for

36 careful coupling conditions, so that the scheme is stable, without altering too much
37 the local flow dynamics.

38

39 A first coupling method consists in enforcing a uniform pressure obtained from the
40 reduced model at the coupling boundary. When a variational formulation is used,
41 e.g. with the finite element method, it is more natural to replace the pressure with
42 the normal component of the normal stress. However stability analyses show that
43 the convective term on the boundary can be responsible for numerical instabilities
44 in the presence of reverse flow. Some Navier-Stokes formulations involve the total
45 pressure in their natural boundary conditions (e.g. [5]). This has been shown to
46 lead to an energetically stable coupling between 3D and reduced models of blood
47 flow (e.g. [16, 17]). Several authors have been expecting instabilities when the
48 total pressure is not included in the transmission conditions but have not seen them
49 numerically [9, 17]. In formulations based on static pressure, a dissipative stabi-
50 lization has been proposed to counteract the destabilizing effect of the convective
51 boundary term (see [4]). We also refer to [11, 12] where similar ideas were intro-
52 duced. A boundary condition based on enforcing the continuity of pressure on the
53 one hand and of a linear combination of flow and energy fluxes on the other hand,
54 has been proven to be energetically stable, but it does not necessarily conserve mass
55 [14]. More recently, a local regularization of the fluid velocity along the tangential
56 directions has been developed in [6]. In all these methods, the reduced model pres-
57 sure is imposed as a uniform boundary condition for the Navier-Stokes equations.
58 But in complex flow, such as with reverse flow, there is *a priori* no reason that the
59 normal traction or the total pressure is uniform on a coupling boundary. For sta-
60 bilized methods, the added term introduces some non-uniformity that has also no
61 obvious reason to correspond to the physiological flow at hand.

62

63 In this article, we propose a new method to handle the outflow boundary condi-
64 tions, by coupling the 3D Navier-Stokes equations with another 3D compartment.
65 This artificial compartment involves modified Navier-Stokes equations that mimic
66 a three-element Windkessel model [19] (as an example of reduced model). The
67 advantages of such an approach are that the coupling 1) does not enforce a uniform
68 traction at the interface, 2) is energetically close to the usual 3D Navier-Stokes
69 - Windkessel solution, without the potentially destabilizing convective boundary
70 term, 3) is provably stable in the energy norm without needing a total pressure for-
71 mulation. Besides, a strategy of adding an artificial 3D part can be very useful in
72 a commercial code that does not allow the users to implement any 0D boundary
73 conditions.

74 Our contributions with respect to the existing works considering a 3D com-
75 partment (e.g. [27]) are the following. First, our artificial compartment is more
76 complex since it includes two different kinds of dissipation and one term repre-
77 senting an elastic potential energy. This allows us to mimic an RCR Windkessel
78 model, which is important in our applications. Second, we investigate how this
79 artificial compartment affects outflow instabilities typically encountered in hemo-
80 dynamics; third, we make a numerical comparison of different outflow boundary
81 conditions in realistic hemodynamics test cases.

82

83 In the next part of this article we present existing coupling methods, derive the cor-
84 responding energy balance. In this context, we present our new modified Navier-
85 Stokes system and analyze its stability. The last part of the methods section is
86 devoted to the numerical implementation. The results are then illustrated on differ-
87 ent reverse flow situations, namely three patient-specific cases of numerical blood
88 flow simulations in arteries in the pulmonary and the systemic sides for healthy or
89 diseased configurations. The different methods are compared qualitatively, looking

90 at the velocity fields at the coupling interface, and quantitatively on the flow and
 91 pressure. In some cases, the results are compared to a reference solution obtained
 92 on a larger geometry. Finally, a discussion with results of the literature is proposed
 93 and possible extensions are presented.

94 **2. Methods**

95 *2.1. Problem formulations*

96 Blood is assumed to be a Newtonian fluid flowing in a rigid domain Ω_1 . The
 97 incompressible Navier-Stokes equations are solved with no-slip condition on the
 98 wall Γ and with a Dirichlet boundary condition on the velocity at the inlet Γ_{in} (the
 99 notation is defined in Figure 1):

$$\rho \frac{\partial \mathbf{u}}{\partial t} + \rho(\mathbf{u} \cdot \nabla \mathbf{u}) + \nabla p - 2\mu \nabla \cdot \boldsymbol{\varepsilon}(\mathbf{u}) = 0 \quad (1)$$

$$\nabla \cdot \mathbf{u} = 0 \quad (2)$$

$$\mathbf{u}|_{\Gamma} = 0 \quad (3)$$

$$\mathbf{u}|_{\Gamma_{\text{in}}} = \mathbf{u}_{\text{in}} \quad (4)$$

100 where $\mathbf{u} : \Omega_1 \times \mathbb{R}^+ \rightarrow \mathbb{R}^3$ is the velocity, $p : \Omega_1 \times \mathbb{R}^+ \rightarrow \mathbb{R}$ is the pressure, and
 101 $\boldsymbol{\varepsilon}(\mathbf{u}) = \frac{1}{2}(\nabla \mathbf{u} + \nabla \mathbf{u}^T)$ denotes the strain rate tensor.

102 The system (1)-(4) has to be complemented with boundary conditions at the out-
 103 let Γ_{out} , where the Navier-Stokes equations are coupled to a reduced-order model
 104 which takes into account the rest of the vessels. Here the names ‘‘inlet’’ and ‘‘out-
 105 let’’ are chosen for convenience, but any of these can have some positive or negative
 106 flow rate over time. Three possible approaches that have been proposed in the lit-
 107 erature are presented below. Then, the main contribution of this study, based on a
 108 3D-3D coupling, is introduced.

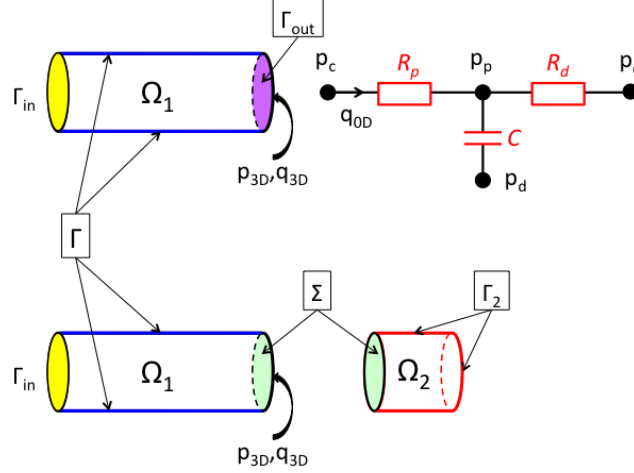

Figure 1: top: 3D-0D coupling scheme, bottom: 3D-3D coupling scheme.

109 *2.2. Review of three existing approaches*

110 *Formulation 1: 3D-0D* . The most common idea consists in enforcing a uniform
 111 normal stress at the outlet, equal to a pressure p_c given by a reduced model:

$$\boldsymbol{\sigma} \cdot \mathbf{n} = -p_c \mathbf{n}, \quad \text{on } \Gamma_{\text{out}}, \quad (5)$$

112 where $\boldsymbol{\sigma} = -p\mathbf{I} + 2\mu\boldsymbol{\varepsilon}(\mathbf{u})$. In a finite element framework, this is easily done with a
 113 Neumann boundary condition. The advantage of this formulation is its simplicity.
 114 Although stable in many practical situations, instabilities can be observed in pres-
 115 ence of complex reverse flow. It will be shown in Section 2.4 that an uncontrolled
 116 term appears in the energy balance. This is a possible reason of the observed insta-
 117 bilities. In addition, enforcing a uniform normal stress on a section where the flow
 118 is complex may generate spurious vortices that can also lead to instabilities.

119 *Formulation 2: 3D-0D-Stab* . To cure the instabilities that may appear during
 120 backflow with Formulation 1, a stabilization method was proposed in [4]. This
 121 approach consists in modifying (5) as follows (here written in a slightly more gen-
 122 eral form):

$$\boldsymbol{\sigma} \cdot \mathbf{n} = -p_c \mathbf{n} - \rho \theta (\mathbf{u} \cdot \mathbf{n})_- \mathbf{u}, \quad \text{on } \Gamma_{\text{out}}, \quad (6)$$

123 where $(\mathbf{u} \cdot \mathbf{n})_-$ is equal to $-(\mathbf{u} \cdot \mathbf{n})$ if $\mathbf{u} \cdot \mathbf{n} \leq 0$, and is equal to 0 if not, and where θ
 124 has to be fixed.

125 This method is simple to implement and can be shown to be stable in the energy
 126 norm for $\theta \geq 0.5$. In practice, it proves to be very efficient at reducing the outlet
 127 instabilities. It was successfully tested in particular in [29, 36]. Two situations have
 128 to be distinguished here. When the backflow is due to spurious vortices induced by
 129 the presence of an artificial boundary, this effect is desirable. But it is well-known
 130 that a physical backflow can appear in some vessels during diastole. In those cases,
 131 the stabilization term artificially takes out of the system an energy that should enter
 132 through the outlet.

133 *Formulation 3: 3D-0D-Ptot* . Another approach considers a formulation of the
 134 Navier-Stokes equations that involves the total pressure (e.g. [5, 22]):

$$\boldsymbol{\sigma} \cdot \mathbf{n} - \frac{\rho}{2} |\mathbf{u}|^2 \mathbf{n} = -p_c \mathbf{n}, \quad \text{on } \Gamma_{\text{out}}. \quad (7)$$

135 This formulation, advocated in particular in [16, 17], can be proved to be stable in
 136 the energy norm (see below). But in blood flow, the total stress is far from being
 137 uniform on a section. Note that this is even not true for Poiseuille or Womersley
 138 flows. As a consequence, this formulation leads to large spurious velocity vectors,
 139 even for simple configurations [22]. As in Formulation 1, spurious vortices can be
 140 generated at this interface and can eventually trigger instabilities.

141 *2.3. A new formulation*

142 *Formulation 4a: 3D-3D* . We propose a possible alternative to the previous ap-
 143 proaches. System (1)-(4) is coupled to a modified Navier-Stokes system. Instead
 144 of a 0D model, an artificial 3D domain Ω_2 is added to the 3D domain of interest Ω_1
 145 (bottom of Figure 1). In Ω_2 , the Navier-Stokes equations are modified by adding
 146 terms to recover an energy balance similar to the one obtained with Formulation 3.
 147 The resulting system can be written in a compact form in $\Omega_1 \cup \Omega_2$:

$$\rho \frac{\partial \mathbf{u}}{\partial t} + \rho \mathbf{u} \cdot \nabla \mathbf{u} + \nabla p - 2\mu \nabla \cdot \boldsymbol{\varepsilon}(\mathbf{u}) + \gamma \mathbf{u} + \rho \frac{\mathbf{u}}{2} \nabla \cdot \mathbf{u} = 0 \quad (8)$$

$$\alpha \frac{\partial p}{\partial t} + \beta p + \nabla \cdot \mathbf{u} = 0 \quad (9)$$

$$\mathbf{u}|_{\Gamma \cup \Gamma_2} = 0 \quad (10)$$

148 where α , β and γ vanish in Ω_1 , to recover the standard equations (1)-(4), and are
 149 positive in Ω_2 . As indicated in Figure 1, the surface Γ_2 consists of the wall of
 150 the added artificial volume, i.e. $\Gamma_2 = \partial\Omega_2 \setminus \Sigma$. In other words the added artificial
 151 surface acts as a ‘‘cork’’.

152 Parameter α is a distributed version of the capacitance (C) in the Windkessel model.
 153 Parameters γ and $1/\beta$ play the role of the proximal (R_p) and distal (R_d) resistances
 154 respectively. Their values will be discussed in Section 2.4. Note that the term βp
 155 acts as a sink, whereas the term $\alpha \partial_t p$ acts as a sink when the pressure increases and
 156 as a source when the pressure decreases. The additional term $\rho \frac{\mathbf{u}}{2} \nabla \cdot \mathbf{u}$ is necessary to
 157 ensure stability in the energy norm, because the fluid is no longer incompressible in
 158 the artificial domain Ω_2 . The equations in the two domains Ω_1 and Ω_2 are coupled
 159 through the usual transmission conditions, with \mathbf{n} being defined on Σ as going from
 160 Ω_1 to Ω_2 :

$$\mathbf{u}_1 = \mathbf{u}_2, \text{ and } \boldsymbol{\sigma}_1 \cdot \mathbf{n} = \boldsymbol{\sigma}_2 \cdot \mathbf{n}, \quad \text{on } \Sigma, \quad (11)$$

161 which are automatically satisfied when a standard variational formulation of equa-
 162 tions (8)-(10) is set on the whole domain $\Omega_1 \cup \Omega_2$.

163 Contrary to what happened with the three previous formulations, the information
 164 coming from the “downstream part” is not uniform on the outflow section Γ_{out} .

165 Contrary to Formulation 1, an inequality can be proved to control the energy of the
 166 system. Compared to Formulation 2, it can let energy enter into the system through
 167 Γ_{out} in the presence of a physical backflow.

168 *Formulation 4b.* As a variant, we also propose a hybrid **3D-3D-0D** coupling method
 169 where the Navier-Stokes equations are coupled to the modified Navier-Stokes model,
 170 which is itself coupled to a 3-element Windkessel reduced model, as shown in Fig-
 171 ure 2 .

172

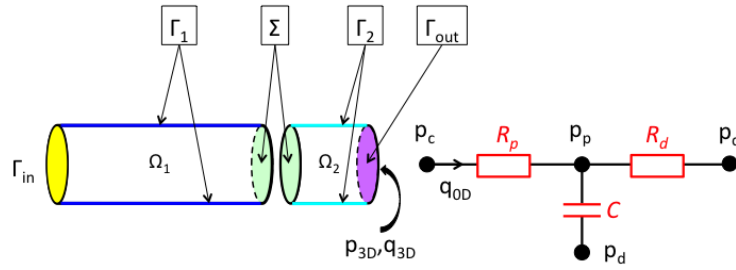

Figure 2: **3D-3D-0D** coupling approach (formulation 4b), where Ω_1 is the domain of interest, Ω_2 is an artificial added part, coupled to a 3-element Windkessel model.

173 In the whole domain $\Omega_1 \cup \Omega_2$,

$$\rho \frac{\partial \mathbf{u}}{\partial t} + \rho(\mathbf{u} \cdot \nabla \mathbf{u}) + \nabla p - 2\mu \nabla \cdot \boldsymbol{\varepsilon}(\mathbf{u}) + \gamma \mathbf{u} = 0 \quad (12)$$

$$\nabla \cdot \mathbf{u} = 0 \quad (13)$$

$$\mathbf{u}|_{\Gamma_1 \cup \Gamma_2} = 0 \quad (14)$$

$$\mathbf{u}|_{\Gamma_{\text{in}}} = \mathbf{u}_{\text{in}} \quad (15)$$

174 where $\gamma = 0$ in Ω_1 , with the usual transmission conditions (11). We finally couple
 175 a 3-element Windkessel model to the system (12)-(15) with the **3D-0D** coupling
 176 method,

$$\boldsymbol{\sigma} \cdot \mathbf{n} = -p_c \mathbf{n}, \quad \text{on } \Gamma_{\text{out}}, \quad (16)$$

177 2.4. Stability analysis

178 In this section, the energy equations of the various formulations presented above
 179 are derived. Without loss of generality, the reduced-order model providing the
 180 pressure p_c in Formulations 1, 2 and 3, is assumed for now to result from a standard
 181 RCR Windkessel model (Figure 1, top):

$$C \frac{dp_p}{dt} + \frac{p_p - p_d}{R_d} = q \quad (17)$$

$$p_c - p_p = R_p q \quad (18)$$

182 where $q = \int_{\Gamma_{\text{out}}} \mathbf{u} \cdot \mathbf{n} ds$. For the sake of simplicity, we assume that the distal pressure
 183 p_d is constant and equal to zero.

184

185 Multiplying (18) by q and (17) by p_p leads to the energy equation of the lumped
 186 parameter model:

$$p_c q = C \frac{d}{dt} \left(\frac{p_p^2}{2} \right) + R_p q^2 + \frac{p_p^2}{R_d} \quad (19)$$

We define the kinetic energy $E_{K_{\Omega_1}}$, the viscous power $P_{V_{\Omega_1}}$ and the energy P_{in} entering the domain through Γ_{in} , respectively by:

$$E_{K_{\Omega_1}} = \int_{\Omega_1} \frac{\rho}{2} |\mathbf{u}|^2 dx, \quad (20)$$

$$P_{V_{\Omega_1}} = 2\mu \int_{\Omega_1} \boldsymbol{\varepsilon}(\mathbf{u}) : \boldsymbol{\varepsilon}(\mathbf{u}) dx, \quad (21)$$

$$P_{\text{in}} = \int_{\Gamma_{\text{in}}} \boldsymbol{\sigma} \cdot \mathbf{n} \cdot \mathbf{u} ds - \rho \int_{\Gamma_{\text{in}}} \frac{|\mathbf{u}|^2}{2} \mathbf{n} \cdot \mathbf{u} ds. \quad (22)$$

187 *Energy balance of Formulation 1 (3D-0D coupling).* Multiplying (1) by \mathbf{u} and
188 integrating over Ω_1 :

$$\frac{d}{dt} \int_{\Omega_1} \frac{\rho}{2} |\mathbf{u}|^2 dx + \rho \int_{\Omega_1} \mathbf{u} \cdot \nabla \left(\frac{|\mathbf{u}|^2}{2} \right) dx + 2\mu \int_{\Omega_1} \boldsymbol{\varepsilon}(\mathbf{u}) : \boldsymbol{\varepsilon}(\mathbf{u}) dx + \int_{\Omega_1} \nabla p \cdot \mathbf{u} dx = 0. \quad (23)$$

189 Using (2) and the no-slip condition on the wall, the energy equation in Ω_1 reads:

$$\frac{d}{dt} E_{K_{\Omega_1}} + P_{V_{\Omega_1}} = P_{\text{in}} + \int_{\Gamma_{\text{out}}} \boldsymbol{\sigma} \cdot \mathbf{n} \cdot \mathbf{u} ds - \rho \int_{\Gamma_{\text{out}}} \frac{|\mathbf{u}|^2}{2} \mathbf{n} \cdot \mathbf{u} ds.$$

190 Considering the coupling condition (5) and the energy equation of the 0D model
191 (19), the global energy balance of the **3D-0D** coupling method is obtained:

$$\frac{d}{dt} E_{K_{\Omega_1}} + P_{V_{\Omega_1}} + C \frac{d p_p^2}{dt} \frac{1}{2} + \frac{p_p^2}{R_d} + R_p q^2 = P_{\text{in}} - \rho \int_{\Gamma_{\text{out}}} \frac{|\mathbf{u}|^2}{2} \mathbf{n} \cdot \mathbf{u} ds \quad (24)$$

192 In the presence of reverse flow at an outlet ($\mathbf{u} \cdot \mathbf{n} < 0$) the last term may thus have
193 a destabilizing effect.

194 *Energy balance of Formulation 2 (3D-0D-Stab coupling).* With the same compu-
195 tation as in Formulation 1, but considering (6) instead of (5) as a coupling condi-
196 tion, the energy equation of Formulation 2 reads:

$$\frac{d}{dt} E_{K_{\Omega_1}} + P_{V_{\Omega_1}} + C \frac{d p_p^2}{dt} \frac{1}{2} + \frac{p_p^2}{R_d} + R_p q^2 = \begin{cases} P_{\text{in}} - \frac{\rho}{2} \int_{\Gamma_{\text{out}}} |\mathbf{u}|^2 (\mathbf{u} \cdot \mathbf{n}) ds, & \text{if } \mathbf{u} \cdot \mathbf{n} \geq 0 \\ P_{\text{in}} - \rho \left(\frac{1}{2} - \theta \right) \int_{\Gamma_{\text{out}}} |\mathbf{u}|^2 (\mathbf{u} \cdot \mathbf{n}) ds, & \text{if } \mathbf{u} \cdot \mathbf{n} < 0 \end{cases} \quad (25)$$

197 This formulation is therefore stable in the energy norm for $\theta \geq 0.5$. If $\theta = 0.5$,
 198 as in [29, 36], the potentially destabilizing term of (24) is exactly balanced by the
 199 artificial dissipation when $\mathbf{u} \cdot \mathbf{n} < 0$. In some publications, a stronger dissipation is
 200 chosen (e.g. $\theta = 1$ in [4]).

201 *Energy balance of Formulation 3 (3D-0D-Ptot coupling):* . When coupling is done
 202 with the total pressure (7), the potentially destabilizing term of (24) disappears in
 203 the energy balance:

$$\frac{d}{dt}E_{K_{\Omega_1}} + P_{V_{\Omega_1}} + C \frac{d}{dt} \frac{p_p^2}{2} + \frac{p_p^2}{R_d} + R_p \mathbf{q}^2 = P_{\text{in}} \quad (26)$$

204 This formulation is therefore stable in the energy norm.

205 *Energy balance of Formulation 4a (3D-3D coupling):* . As in Formulation 1, the
 206 energy equation in the domain of interest Ω_1 reads:

$$\frac{d}{dt}E_{K_{\Omega_1}} + P_{V_{\Omega_1}} = P_{\text{in}}^{\Omega_1} + \int_{\Sigma} (\boldsymbol{\sigma} \cdot \mathbf{n} \cdot \mathbf{u} - \rho \frac{|\mathbf{u}|^2}{2} \mathbf{n} \cdot \mathbf{u}) ds \quad (27)$$

207 Similarly, in the artificial domain Ω_2 , from the modified Navier-Stokes equation
 208 (8)-(9)-(10):

$$\frac{d}{dt}E_{K_{\Omega_2}} + P_{V_{\Omega_2}} + \gamma \int_{\Omega_2} |\mathbf{u}|^2 dx - \int_{\Omega_2} p \nabla \cdot \mathbf{u} dx = - \int_{\Sigma} \boldsymbol{\sigma} \cdot \mathbf{n} \cdot \mathbf{u} ds + \rho \int_{\Sigma} \frac{|\mathbf{u}|^2}{2} \mathbf{n} \cdot \mathbf{u} ds \quad (28)$$

209 Using equation (9),

$$\begin{aligned} & \frac{d}{dt}E_{K_{\Omega_2}} + P_{V_{\Omega_2}} + \alpha \frac{d}{dt} \int_{\Omega_2} \frac{p^2}{2} dx + \beta \int_{\Omega_2} p^2 dx + \gamma \int_{\Omega_2} |\mathbf{u}|^2 dx \\ & = - \int_{\Sigma} \boldsymbol{\sigma} \cdot \mathbf{n} \cdot \mathbf{u} ds + \rho \int_{\Sigma} \frac{|\mathbf{u}|^2}{2} \mathbf{n} \cdot \mathbf{u} ds \end{aligned} \quad (29)$$

210 Adding these two relations, the boundary terms in the right-hand side cancel out,
 211 due to the transmission condition (11), and the energy balance of Formulation 4a
 212 is obtained:

$$\frac{d}{dt}E_K^{\Omega_1 \cup \Omega_2} + P_V^{\Omega_1 \cup \Omega_2} + \alpha \frac{d}{dt} \int_{\Omega_2} \frac{p^2}{2} dx + \beta \int_{\Omega_2} p^2 dx + \gamma \int_{\Omega_2} |\mathbf{u}|^2 dx = P_{\text{in}}^{\Omega_1}. \quad (30)$$

213 This formulation is therefore stable in the energy norm. Comparing (30) with (26),
 214 we notice an analogy between α, β, γ and the standard Winkessel parameters. From
 215 this observation, we can set:

$$\alpha \approx C/V, \beta \approx 1/(R_d V), \gamma \approx R_p S/L, \quad (31)$$

216 where V, S and L respectively denote the volume, the section and the length of the
 217 artificial domain Ω_2 .

218 Similarly, the energy balance of *Formulation 4b* (**3D-3D-0D** coupling) is thus:

$$\begin{aligned} & \frac{d}{dt} E_K^{\Omega_1 \cup \Omega_2} + P_V^{\Omega_1 \cup \Omega_2} + \gamma \int_{\Omega_2} |\mathbf{u}|^2 dx \\ & + C \frac{d}{dt} \frac{p_p^2}{2} + \frac{p_p^2}{R_d} + R_p q^2 = P_{\text{in}}^{\Omega_1} - \rho \int_{\Gamma_{\text{out}}} \frac{|\mathbf{u}|^2}{2} \mathbf{n} \cdot \mathbf{u} ds. \end{aligned} \quad (32)$$

219 In this hybrid formulation, the outlet inertial term reappears, but, as will be seen in
 220 the results, this formulation is stable in practice.

221 2.5. Numerical schemes

222 The RCR Windkessel model is discretized with a first-order scheme: assuming that
 223 p_p^n and q^n are known, then p_p^{n+1} and p_c^{n+1} are defined by

$$\begin{aligned} C \frac{p_p^{n+1} - p_p^n}{\Delta t} + \frac{p_p^{n+1}}{R_d} &= q^n, \\ p_c^{n+1} &= p_p^{n+1} + R_p q^n. \end{aligned} \quad (33)$$

224 Denoting $R_d C$ by τ , the pressure transmitted to the 3D model at time t^{n+1} is given
 225 by:

$$p_c^{n+1} = \frac{\frac{\tau}{\Delta t} p_p^n + R_d q^n}{1 + \frac{\tau}{\Delta t}} + R_p q^n. \quad (34)$$

226 The 3D formulations are discretized with a first-order time scheme and P1/P1 sta-
 227 bilized finite element [35]. The nonlinear advection term of the Navier-Stokes

228 equations is treated semi-implicitly. In the following the finite element test func-
 229 tions for the momentum and continuity equations are respectively denoted by \mathbf{v}_h
 230 and q_h .

231 *Formulation 1 (3D-0D)*. Defining the bilinear form:

$$\begin{aligned} A_1^{\Omega}(\mathbf{u}_h^n; (\mathbf{u}_h^{n+1}, p_h^{n+1}), (\mathbf{v}_h, q_h)) &= \int_{\Omega} \left(\frac{\rho}{\Delta t} \mathbf{u}_h^{n+1} + \rho \mathbf{u}_h^n \cdot \nabla \mathbf{u}_h^{n+1} \right) \cdot \mathbf{v}_h dx \\ &+ \int_{\Omega} \mu \nabla \mathbf{u}_h^{n+1} : \nabla \mathbf{v}_h dx - \int_{\Omega} \left(p_h^{n+1} \nabla \cdot \mathbf{v}_h + q_h \nabla \cdot \mathbf{u}_h^{n+1} \right) dx, \end{aligned} \quad (35)$$

232 the variational formulation of the **3D-0D** method reads: Find \mathbf{u}_h^{n+1} and p_h^{n+1} such
 233 that for every \mathbf{v}_h and q_h ,

$$A_1^{\Omega_1}(\mathbf{u}_h^n; (\mathbf{u}_h^{n+1}, p_h^{n+1}), (\mathbf{v}_h, q_h)) = \int_{\Omega_1} \frac{\rho}{\Delta t} \mathbf{u}_h^n \cdot \mathbf{v}_h dx - \int_{\Gamma_{\text{out}}} p_c^{n+1} \mathbf{n} \cdot \mathbf{v}_h ds \quad (36)$$

234 **Remark 2.1.** Note that the weak form of the viscous term is based on the relation
 235 $\mu \Delta \mathbf{u} = 2\mu \nabla \cdot \boldsymbol{\varepsilon}(\mathbf{u})$, valid for an incompressible fluid. The natural condition cor-
 236 responding to this formulation is compatible with Poiseuille and Womersley flows
 237 contrary to the one based on $\boldsymbol{\varepsilon}(\mathbf{u})$ (e.g. [22]). We made this choice to avoid pertur-
 238 bations of the velocity field at the outlet for these basic flows, but the formulation
 239 based on $\boldsymbol{\varepsilon}(\mathbf{u})$ can also be used in practice.

240 *Formulation 2 (3D-0D-Stab)*. Considering the bilinear form (35) and boundary
 241 conditions (6) with $\theta = 0.5$, the **3D-0D-Stab** method variational formulation reads:

242 Find \mathbf{u}_h^{n+1} and p_h^{n+1} such that for every \mathbf{v}_h and q_h ,

$$\begin{aligned} A_1^{\Omega_1}(\mathbf{u}_h^n; (\mathbf{u}_h^{n+1}, p_h^{n+1}), (\mathbf{v}_h, q_h)) &= \\ \int_{\Omega_1} \frac{\rho}{\Delta t} \mathbf{u}_h^n \cdot \mathbf{v}_h dx - \int_{\Gamma_{\text{out}}} p_c^{n+1} \mathbf{n} \cdot \mathbf{v}_h ds - \int_{\Gamma_{\text{out}}} \frac{\rho}{2} (\mathbf{u}_h^n \cdot \mathbf{n})_-(\mathbf{u}_h^{n+1} \cdot \mathbf{v}_h) ds \end{aligned} \quad (37)$$

243 *Formulation 3 (3D-0D-Ptot)*. Defining the bilinear form:

$$\begin{aligned} A_2^{\Omega}(\mathbf{u}_h^n; (\mathbf{u}_h^{n+1}, p_h^{n+1}), (\mathbf{v}_h, q_h)) &= \int_{\Omega} \left(\frac{\rho}{\Delta t} \mathbf{u}_h^{n+1} + \rho (\nabla \times \mathbf{u}_h^{n+1}) \times \mathbf{u}_h^n \right) \cdot \mathbf{v}_h dx \\ &- \int_{\Omega} \frac{\rho}{2} \mathbf{u}_h^{n+1} \cdot \mathbf{u}_h^n \nabla \cdot \mathbf{v}_h dx + \int_{\Omega_1} \mu \nabla \mathbf{u}_h^{n+1} : \nabla \mathbf{v}_h dx - \int_{\Omega} \left(p_h^{n+1} \nabla \cdot \mathbf{v}_h + q_h \nabla \cdot \mathbf{u}_h^{n+1} \right) dx. \end{aligned} \quad (38)$$

244 The variational formulation of the **3D-0D-Ptot** method reads: Find \mathbf{u}_h^{n+1} and p_h^{n+1}
 245 such that for every \mathbf{v}_h and q_h ,

$$A_2^{\Omega_1}(\mathbf{u}_h^n; (\mathbf{u}_h^{n+1}, p_h^{n+1}), (\mathbf{v}_h, q_h)) = \int_{\Omega_1} \frac{\rho}{\Delta t} \mathbf{u}_h^n \cdot \mathbf{v}_h dx - \int_{\Gamma_{\text{out}}} p_c^{n+1} \mathbf{n} \cdot \mathbf{v}_h ds \quad (39)$$

246 **Remark 2.2.** *In this formulation, the total pressure only appears in the boundary*
 247 *condition but the pressure unknown is still the static pressure. It is also possible*
 248 *to consider a formulation, based on the relation $\mathbf{u} \cdot \nabla \mathbf{u}^T = \nabla \left(\frac{|\mathbf{u}|^2}{2} \right)$, where the static*
 249 *pressure is replaced by the total pressure as an unknown [22].*

250 *Formulation 4a (3D-3D).* Defining the bilinear form:

$$\begin{aligned} A_3^{\Omega}(\mathbf{u}_h^n; (\mathbf{u}_h^{n+1}, p_h^{n+1}), (\mathbf{v}_h, q_h)) &= \int_{\Omega} \left(\frac{\rho}{\Delta t} \mathbf{u}_h^{n+1} + \rho \mathbf{u}_h^n \cdot \nabla \mathbf{u}_h^{n+1} \right) \cdot \mathbf{v}_h dx \\ &\quad + \int_{\Omega} \mu \nabla \mathbf{u}_h^{n+1} : \nabla \mathbf{v}_h dx - \int_{\Omega} \left(p_h^{n+1} \nabla \cdot \mathbf{v}_h + q_h \nabla \cdot \mathbf{u}_h^{n+1} \right) dx \\ &\quad + \int_{\Omega} \gamma \mathbf{u}_h^{n+1} \cdot \mathbf{v}_h dx + \int_{\Omega} \frac{\rho}{2} \mathbf{u}_h^{n+1} \cdot \mathbf{v}_h \nabla \cdot \mathbf{u}_h^n dx - \int_{\Omega} \left(\frac{\alpha}{\Delta t} + \beta \right) p_h^{n+1} q_h dx \end{aligned} \quad (40)$$

251 where, $\alpha = \beta = \gamma = 0$ in Ω_1 .

252 The variational formulation of the **3D-3D** method reads: Find \mathbf{u}_h^{n+1} and p_h^{n+1} such
 253 that for every \mathbf{v}_h and q_h ,

$$A_3^{\Omega_1 \cup \Omega_2}(\mathbf{u}_h^n; (\mathbf{u}_h^{n+1}, p_h^{n+1}), (\mathbf{v}_h, q_h)) = \int_{\Omega_1 \cup \Omega_2} \left(\frac{\rho}{\Delta t} \mathbf{u}_h^n \cdot \mathbf{v}_h - \frac{\alpha}{\Delta t} p_h^n q_h \right) dx \quad (41)$$

254 The variational formulation of *Formulation 4b (3D-3D-0D)* is the same with the
 255 addition on the right hand side of $-\int_{\Gamma_{\text{out}}} p_c^{n+1} \mathbf{n} \cdot \mathbf{v}_h dx$, and taking $\alpha = 0$, $\beta = 0$.

256 3. Results

257 In this section we present results of all these coupling methods for patient-specific
 258 cases in the systemic and the pulmonary sides where the flow regimes are very
 259 different. The first case is a typical case of flow in pulmonary arteries: the flow

260 field is not so complex, and yet prescribed inlet back flow generates stability is-
261 sues. For the second case the main advantages are first that the effect of artificially
262 cutting the geometry can be assessed, and second that, due to the bifurcation close
263 to the inlet, it is a case of more complex flow, although at the inlet no back flow is
264 imposed. Finally, the third case tests a typical systemic hemodynamics scenario:
265 instabilities there are generally observed during deceleration after peak systole.
266 These three cases thus reflect the diversity of typical numerical instabilities seen in
267 cardiovascular simulations. Through them, we highlight differences, benefits and
268 disadvantages in the instability treatments.

269

270 For each case, the choice of Windkessel parameters is described. For the **3D-3D**
271 model, parameters were chosen following equations 31, given the specific added
272 volume dimensions. Finally, parameters of the hybrid **3D-3D-0D** method were de-
273 fined as follows: in the artificial parts, γ is chosen as 10% of the γ in the **3D-3D**
274 model, while correspondingly the proximal resistance of the Windkessel model is
275 decreased by 10% compared to the original value.

276

277 *3.1. Adult patient-specific pulmonary artery: a case with inlet backflow*

278 This patient specific geometrical model is an adult pulmonary artery (PA). Velocity
279 is prescribed at the inlet of the model, as a plug profile following the flow tracing of
280 Figure 3. There is around 16% of reverse flow. The maximum flow rate is around
281 $378\text{cm}^3/\text{s}$, leading to a highest Reynolds number of 2400. During the decelera-
282 tion after systole, physical reverse flow occurs with a minimal flow rate around
283 $-66\text{cm}^3/\text{s}$. Figure 3 also shows on the left-hand side the original geometrical
284 model containing 107K tetrahedra, with both outlets coupled to 3-element Wind-
285 kessel models by successively the **3D-0D**, **3D-0D-Stab** and **3D-0D-Ptot** methods.

286 On the right-hand side, the geometrical model with the added artificial parts con-
 287 sists of 127K tetrahedra: there the coupling is done with the **3D-3D** and **3D-3D-0D**
 288 methods.
 289

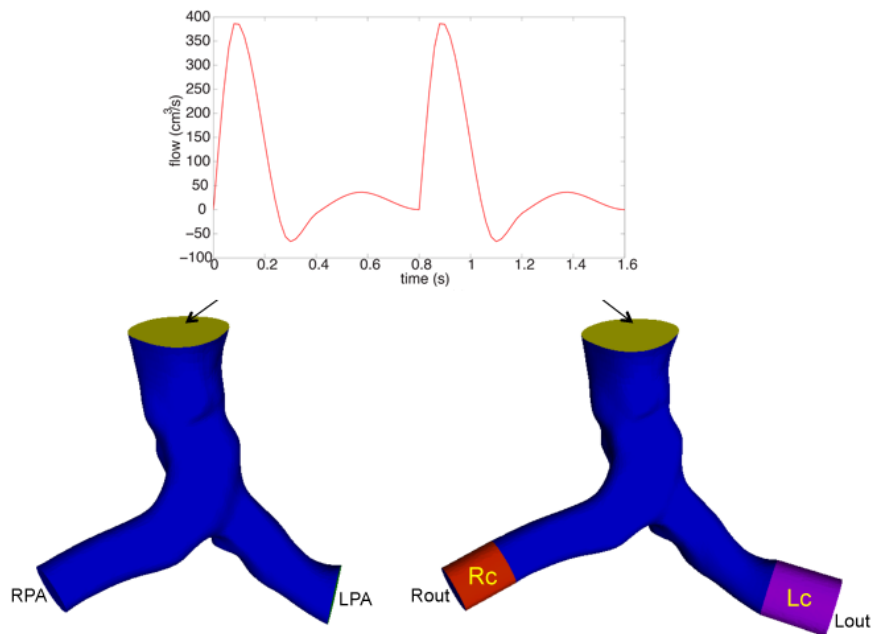

Figure 3: Original geometrical model in blue (left) and geometrical model with the added outlet 3D artificial parts in red and purple (right). Inlet flow tracing over two cardiac cycles.

290 Table 1 summarizes the parameters of the different coupling methods. On the left-
 291 hand side, the Windkessel model parameters are the ones of the **3D-0D**, **3D-0D-**
 292 **Stab** and **3D-0D-Ptot** coupling approaches. They were chosen to represent physio-
 293 logical PA pressure pulses, assuming symmetry between the two lung vasculatures
 294 [21]. The **3D-3D** (right) and **3D-3D-0D** (below) parameters in the artificial added
 295 parts are displayed, given that the added volumes are such that V , S and L are re-
 296 spectively 5 cm^3 , 2.5 cm^2 , and 2 cm on both sides.

	LPA	RPA		Lc	Rc
R_p	$4 \cdot 10^1$	$4 \cdot 10^1$	γ	$4.9 \cdot 10^1$	$4.9 \cdot 10^1$
C	$1 \cdot 10^{-3}$	$1 \cdot 10^{-3}$	α	$2 \cdot 10^{-4}$	$2 \cdot 10^{-4}$
R_d	$3 \cdot 10^2$	$3 \cdot 10^2$	β	$6.7 \cdot 10^{-4}$	$6.7 \cdot 10^{-4}$

	Lout	Rout		Lc	Rc
R_p	$3.6 \cdot 10^1$	$3.6 \cdot 10^1$	γ	4.9	4.9
C	$1 \cdot 10^{-3}$	$1 \cdot 10^{-3}$	α	0	0
R_d	$3 \cdot 10^2$	$3 \cdot 10^2$	β	0	0

Table 1: R_p and R_d in $\text{g cm}^{-4} \text{s}^{-1}$, and C in $\text{g}^{-1} \text{cm}^4 \text{s}^2$, α in $\text{g}^{-1} \text{cm s}^2$, β in $\text{g}^{-1} \text{cm s}$, and γ in $\text{g cm}^{-3} \text{s}^{-1}$.

298 This example is a typical PA physiological case. In Figure 4 velocity fields are
 299 shown during forward peak flow (top) and in presence of backflow (bottom), com-
 300 paring the **3D-0D**, **3D-0D-Stab**, **3D-3D** and **3D-3D-0D** coupling methods. During
 301 forward flow, the four approaches lead to very similar velocity fields. In fact, in
 302 this configuration the convective stabilization is off, which is verified by the same
 303 results obtained for the **3D-0D** or **3D-0D-Stab** methods. During backflow, the
 304 **3D-0D** coupling method exhibits perturbations with inward vectors which are very
 305 large relative to the flow rate for a few time steps. The **3D-0D-Stab** method, while
 306 stable, perturbs the hemodynamics by reducing the velocity vectors to almost zero.
 307 The **3D-3D** approach allows to recover a backflow without instabilities, and simi-
 308 larly for **3D-3D-0D**.

309 In Figure 5, the **3D-0D-Ptot** method exhibits velocity vectors with strong spu-
 310 rious radial components at the outlet surface [22]. Spurious in and out of plane
 311 vectors can also be seen, even though flow is maximally forward. Moreover,
 312 computations are not diverging but lead to a very large in-plane pressure gradi-
 313 ent ($\Delta P = 26.50 \text{ mmHg}$), which is not relevant from a physiological point of view.

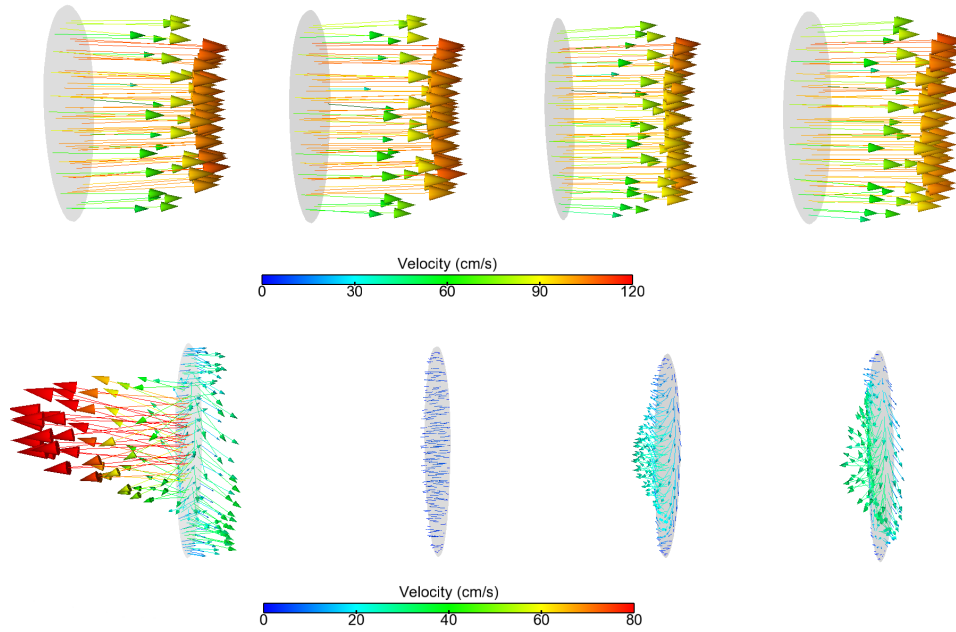

Figure 4: Velocity fields at the LPA interface, when flow at the inlet is maximal forward (top, $t=0.10s$, $Q_{max} = 378 \text{ cm}^3/s$) and is reverse (bottom, $t=1.06s$, $Q_{min} = -66 \text{ cm}^3/s$) with the **3D-0D**, **3D-0D-Stab**, **3D-3D** and **3D-3D-0D** coupling methods from left to right.

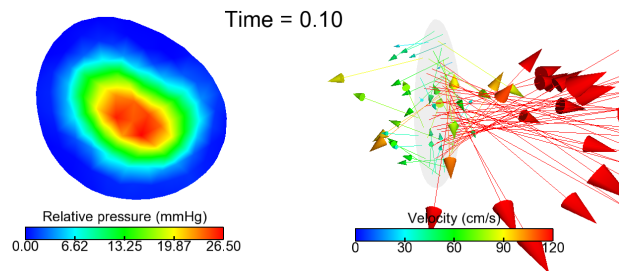

Figure 5: In-plane pressure relative to its minimum value (left) and velocity fields (right) at the LPA interface during maximal forward flow ($t=0.1s$) with the **3D-0D-Ptot** coupling method.

315 The time-varying flow rates and average pressure at the coupling surfaces are now
316 analyzed (Figure 6 shows the LPA). For each coupling method, similar flow and
317 pressure results are found on both the left and right-hand sides. Flow and pressure
318 from the **3D-0D-Ptot** method are not represented as the obtained values were non-
319 physiological: although the simulation did not diverge, they were too high with
320 spurious high-frequency tracings. For all other coupling methods, flow varies over
321 time very similarly. Pressure varies over 3 to 20 mmHg, in exactly the same way
322 for the **3D-0D** and **3D-0D-Stab** methods, but a few mmHg lower for the **3D-3D**
323 model, while for the **3D-3D-0D** model it is closer to the other couplings.

324 At this point however, it is hard to conclude on which method is best reproduc-
325 ing the real flow behavior, because we do not have access to the three dimensional
326 downstream domain. But this case is highlighting the robustness of the **3D-0D-**
327 **Stab** and **3D-3D** coupling methods to avoid large numerical artefacts due to phys-
328 iological reverse flow in a patient-specific case.

329

330 *3.2. Diseased child pulmonary arteries: a challenging fluid dynamics case*

331 This patient specific geometry is the first generation of a pulmonary arterial tree of
332 a child affected by a congenital heart disease, the single ventricle pathology (pul-
333 monary atresia with intact ventricular septum). This patient underwent a so-called
334 stage 1 surgical procedure consisting of an anastomosis between the systemic and
335 pulmonary circulatory systems *via* a 3.5mm artificial shunt. For more information
336 about this patient and its model reconstruction see [1].

337

338 Figure 7 represents the complete geometrical model (918K tetrahedra, six outlets),
339 the short model with cut pulmonary artery branches (471K tetrahedra, two outlets),
340 and the short model with its artificial parts to the outlet surfaces (505K tetrahedra,

Flow at left pulmonary arte

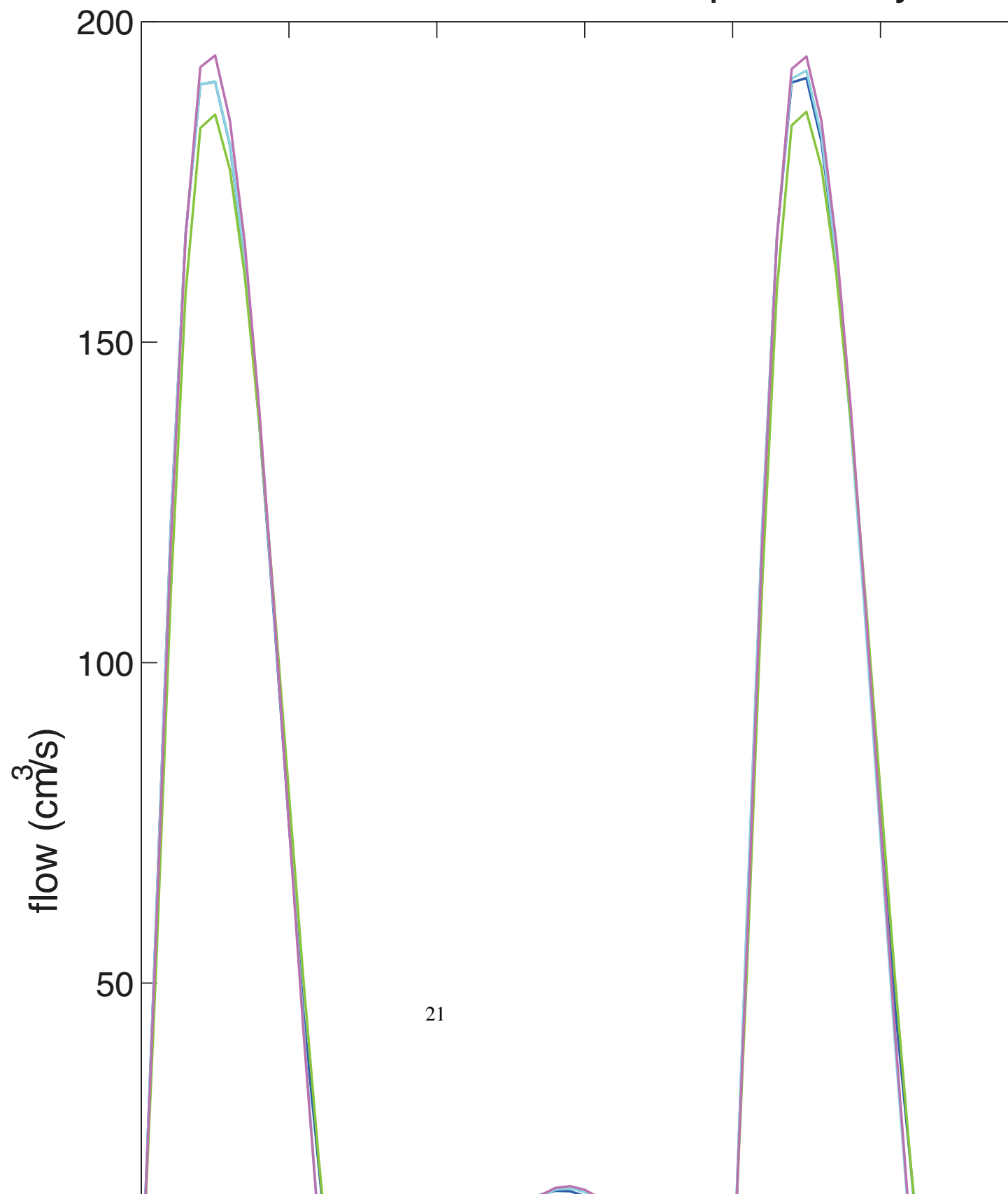

21

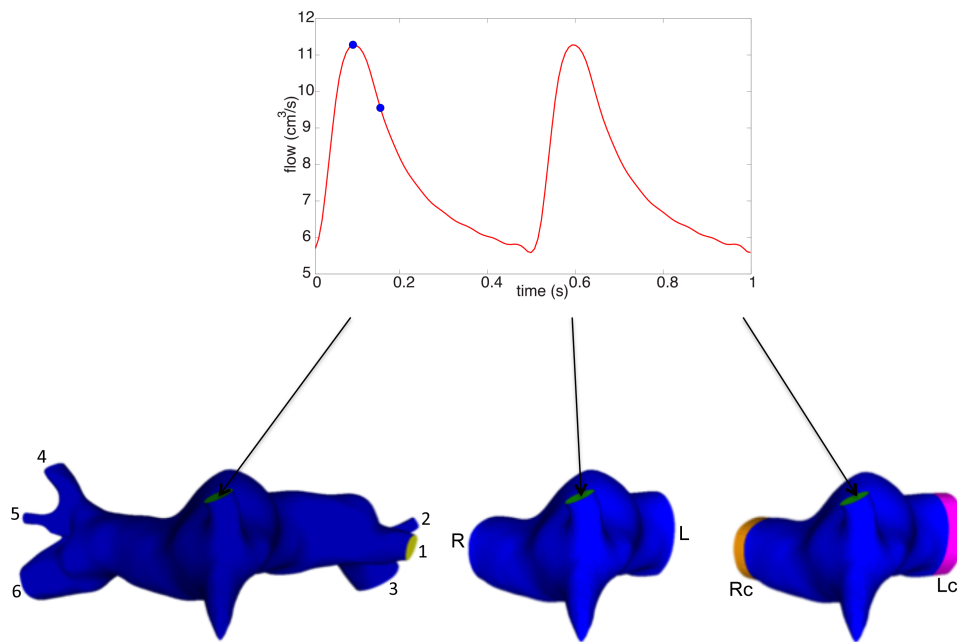

Figure 7: From left to right: complete model (with outlets 1 – 6), short model (two outlets, R for the RPA and L for the LPA), and short model with the two artificial three dimensional parts on each side, R_c and L_c . Top: imposed inflow shown over two cycles, with the two dots representing maximum flow and decelerating flow respectively.

341 2 outlets). As in the previous case, velocity was prescribed at the inlet with a
 342 plug profile, following a typical shunt flow tracing. The highest Reynolds num-
 343 ber is 3000. The flow rate varies over one cardiac cycle between $5.8\text{cm}^3/\text{s}$ and
 344 $11.2\text{cm}^3/\text{s}$: there is thus no physical flow reversal prescribed at the inlet. The main
 345 advantages of this case are first that the effect of artificially cutting the geometry
 346 can be assessed, and second that, due to the bifurcation close to the inlet, it is a
 347 case of more complex flow than previously.

348 In Table 2 the values of proximal and distal resistances, and capacitances are given
 349 for each of the six outlets of the complete geometrical model. These values were
 350 generated to reflect clinical measurements [1, 2]. A first simulation is run with the
 351 **3D-0D** coupling approach on the complete geometry. All the coupling methods
 352 with the short models are then compared to this reference simulation.

353

	1	2	3		4	5	6
R_p	$3.19 \cdot 10^1$	$4.73 \cdot 10^1$	$6.38 \cdot 10^0$	R_p	$1.71 \cdot 10^1$	$4.26 \cdot 10^1$	$5.75 \cdot 10^0$
C	$4.40 \cdot 10^{-4}$	$1.79 \cdot 10^{-4}$	$5.50 \cdot 10^{-3}$	C	$1.14 \cdot 10^{-3}$	$2.35 \cdot 10^{-4}$	$1.06 \cdot 10^{-2}$
R_d	$2.45 \cdot 10^2$	$6.13 \cdot 10^2$	$2.95 \cdot 10^1$	R_d	$1.11 \cdot 10^2$	$4.63 \cdot 10^2$	$1.58 \cdot 10^1$

Table 2: R_p and R_d in $\text{g cm}^{-4} \text{s}^{-1}$, and C in $\text{g}^{-1} \text{cm}^4 \text{s}^2$ for the six Windkessel model outlets of the reference simulation in the complete geometrical model.

354 In Table 3, the reduced model parameters for the short geometries are given. They
 355 were generated from the reference model parameters: at both outlets, an equiva-
 356 lent impedance is computed from the three distal outlet Windkessel model of the
 357 complete model. Windkessel model parameters are then optimized to match this
 358 impedance. This Windkessel model is then coupled to the 3D Navier-Stokes equa-
 359 tions with the **3D-0D**, **3D-0D-Stab** and **3D-0D-Ptot** methods. The **3D-3D** param-
 360 eters in the artificial added parts are displayed, given that the added volumes are
 361 such that V , S and L are respectively 0.066cm^3 , 0.33cm^2 , and 0.2cm for the left

362 side and 0.1 cm^3 , 0.49 cm^2 , and 0.2 cm for the right side, reflecting the smaller
 363 dimensions of this child anatomy. The **3D-3D-0D** parameters are hybrid between
 364 the **3D-0D** and **3D-3D** as described in the beginning of the section.

365

	R	L		Rc	Lc
R_p	$4.44 \cdot 10^0$	$5.28 \cdot 10^0$	γ	$7.13 \cdot 10^0$	$1.29 \cdot 10^1$
C	$1.29 \cdot 10^{-2}$	$6.20 \cdot 10^{-3}$	α	$1.96 \cdot 10^{-1}$	$6.35 \cdot 10^{-2}$
R_d	$1.33 \cdot 10^1$	$2.51 \cdot 10^1$	β	$1.14 \cdot 10^0$	$4.09 \cdot 10^{-1}$

Table 3: Parameters for the different coupling methods in the short models: R_p and R_d in $\text{g cm}^{-4} \text{ s}^{-1}$, and C in $\text{g}^{-1} \text{ cm}^4 \text{ s}^2$, α in $\text{g}^{-1} \text{ cm s}^2$, β in $\text{g}^{-1} \text{ cm s}$, and γ in $\text{g cm}^{-3} \text{ s}^{-1}$.

366 In Figure 8 velocity fields in the RPA are compared between the different meth-
 367 ods at the same location during maximal forward flow (left) and deceleration flow
 368 (right). The **reference** case (top) presents no instability because the flow is smoother
 369 at its distal outlets, which is typical of bifurcations quite downstream of complex
 370 flow [39]. At maximal forward flow, it shows complex flow in the RPA. This be-
 371 havior is retrieved on the short model with the **3D-0D** coupling method but with
 372 inwards velocity vectors. However, the computation is close to divergence. The
 373 **3D-0D-Stab** coupling method efficiently kills the reverse velocity vectors at the
 374 coupling surface so that a similar forward flow motion to the **3D-0D** coupling
 375 method is retrieved without backflow. Note that the **3D-3D** coupling leads to a
 376 velocity profile closer to the reference case.

377 Regarding blood flow behavior during the decelerating phase (right column in
 378 Figure 8), there is reverse flow in the **reference** case and a large proportion of the
 379 forward flow is located at the bottom of the surface area. With the **3D-0D** cou-
 380 pling method at outlet surfaces of the cut model, the computation is diverging, but
 381 the **3D-0D-Stab** coupling method leads to a blood flow behavior where velocity
 382 vectors are underestimated at the center and top of the coupling surface area. In

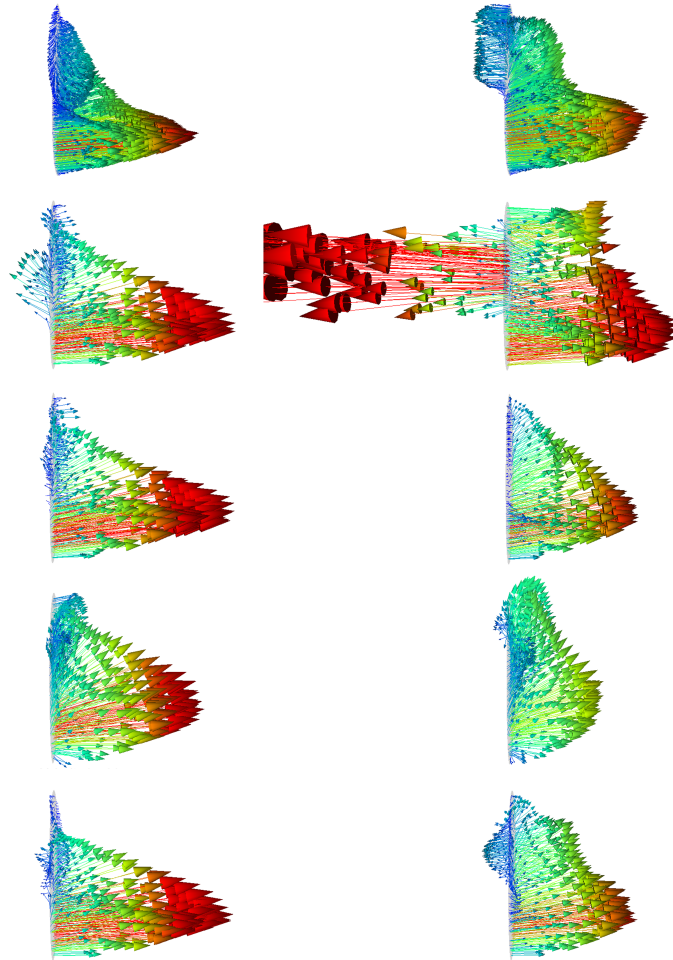

Figure 8: Velocity fields in RPA at peak inlet flow (left, $t=0.0936s$, $Q_{max} = 11.2 \text{ cm}^3/s$) and during decelerating flow (right, $t=0.156s$) comparing the **reference**, **3D-0D**, **3D-0D-Stab**, **3D-3D** and **3D-3D-0D** coupling methods from top to bottom. The two times are shown as dots on the inflow Figure 7. Color encodes velocity magnitude from 0 (blue) to 90 cm/s (red).

383 the **3D-3D** coupling approach, flow motion is more homogeneous in terms of size
384 and direction of the velocity vectors. The **3D-3D-0D** coupling method leads during
385 maximal forward flow to a velocity field close to the coupling of reduced model
386 with the **3D-0D-Stab** method. During deceleration the majority of flow is located
387 at the bottom of the coupling surface and backflow is authorized in the upper part.
388 The obtained flow behavior is thus close to the **reference** case.
389 The velocity field for the **3D-0D-Ptot** coupling method behaves as in the previous
390 patient-specific case of adult pulmonary arteries. However, the computation is di-
391 verging.

392

393 In the figures above, the RPA side is presented. In fact, the LPA is turning in the
394 downstream 3D domain of the **reference** case in such a way that hemodynam-
395 ics are even more different between the reference and the cut models than for the
396 RPA. Next, the resulting flow rates are compared at coupling surfaces (Figure 9
397 shows as an example the RPA), between the **3D-0D** , **3D-0D-Stab** , **3D-3D** and
398 **3D-3D-0D** coupling models. In all cases, most of the flow goes to the RPA, fol-
399 lowing a dynamics close to that of the inlet flow, with a peak in systole followed
400 by a rapid decay. The flow rates oscillate in time in diastole due to the complex
401 flow structures created by the interaction of the impinging inflow and the patient-
402 specific geometry. However, for the **3D-0D** case the flow rates largely oscillate
403 before the simulation diverges. In terms of magnitude, the coupling method that is
404 closer to the **reference** case is the **3D-0D-Stab** method, on both sides. The **3D-3D**
405 coupling approach is leading to a satisfying blood flow behavior but changes the
406 distribution of flow between the left and right-hand sides for this choice of param-
407 eters: it slightly overestimates flow in the RPA and thus underestimates flow in the
408 LPA. However, the hybrid coupling method **3D-3D-0D** is close to the **reference**
409 case. The diverging **3D-0D-Ptot** results are not represented because the simulation

410 diverged early on ($t=0.0936s$).

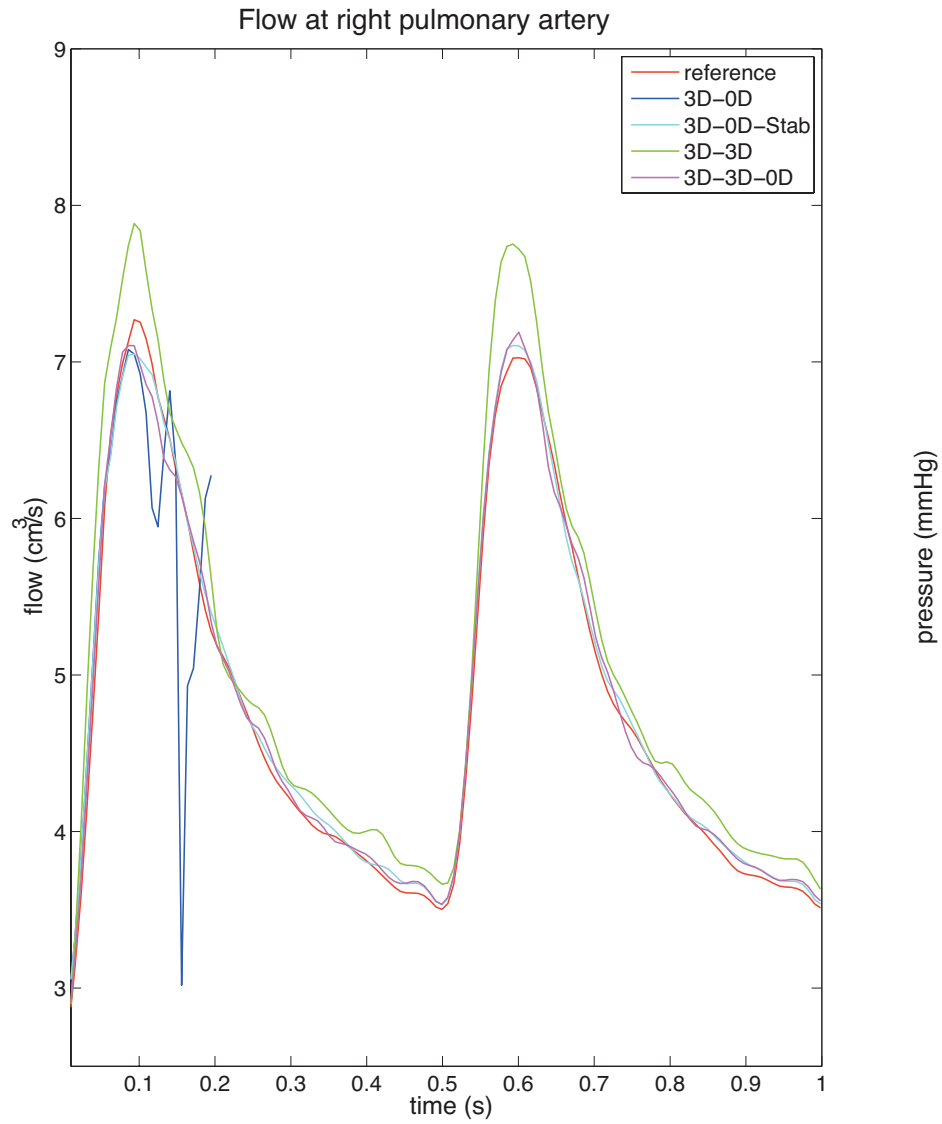

Figure 9: Flow rate (left) and pressure (right) over two cardiac cycles in the RPA for the different coupling methods.

411 Lastly, Figure 9 shows the corresponding pressure waveforms. The time dy-
412 namics are similar for all cases and on both sides, except for the **3D-0D** case which
413 diverges in the first cardiac cycle. After the transitory first cycle, the second cycle is
414 closer to a periodic solution with a sharp rise in systole, followed by a smooth dias-
415 tole decay. The closest results to the **reference** case is the **3D-0D-Stab** method for
416 both sides. The **3D-3D** approach underestimates pressure for both sides. However
417 the hybrid **3D-3D-0D** coupling approach more closely reproduces the **reference**
418 results.

419

420 To summarize this case, both **3D-0D** and **3D-0D-Ptot** couplings lead to divergence
421 of the simulation, although there is negative flow rate neither at the inlet nor at the
422 outlets. This is highlighting the need for robust numerical methods in the pres-
423 ence of complex flow, such as the **3D-0D-Stab** and **3D-3D** or **3D-3D-0D** coupling
424 methods. The three presented similarities and differences with the **reference** case,
425 which is the ground truth, **3D-3D-0D** being the best compromise in this example.

426

427 *3.3. Adult patient-specific aorta: complex flow generated during deceleration*

428 This last patient-specific case is an abdominal adult aorta. Figure 10 consists of
429 the inlet flow rate over time and the three tested geometrical models: the complete
430 3D model containing 608K tetrahedra and 9 outlet surfaces, the short model con-
431 taining 473K tetrahedra and 6 outlet surfaces where the abdominal aorta was cut
432 to remove the iliac branches, and the same cut model but with an artificial 3D part
433 at its descending aorta outlet, containing 499K tetrahedra. Velocity is prescribed
434 at the inlet of the model, as a plug profile following the flow tracing of Figure 10.
435 As is typical in the supra celiac descending aorta, this flow rate does not contain
436 reverse flow over the entire cardiac cycle. The maximal flow is $Q_{\max} = 177 \text{ cm}^3/\text{s}$

437 and the minimal flow is $Q_{\min} = 7 \text{ cm}^3/\text{s}$. Deceleration is large enough to gener-
 438 ate complex flow behavior in all the geometrical models regardless of the outlets
 439 coupling methodology at hand. The complete model is the **reference** where three
 440 dimensional Navier-Stokes equations are coupled to reduced models at every outlet
 441 with the **3D-0D** coupling method.

442

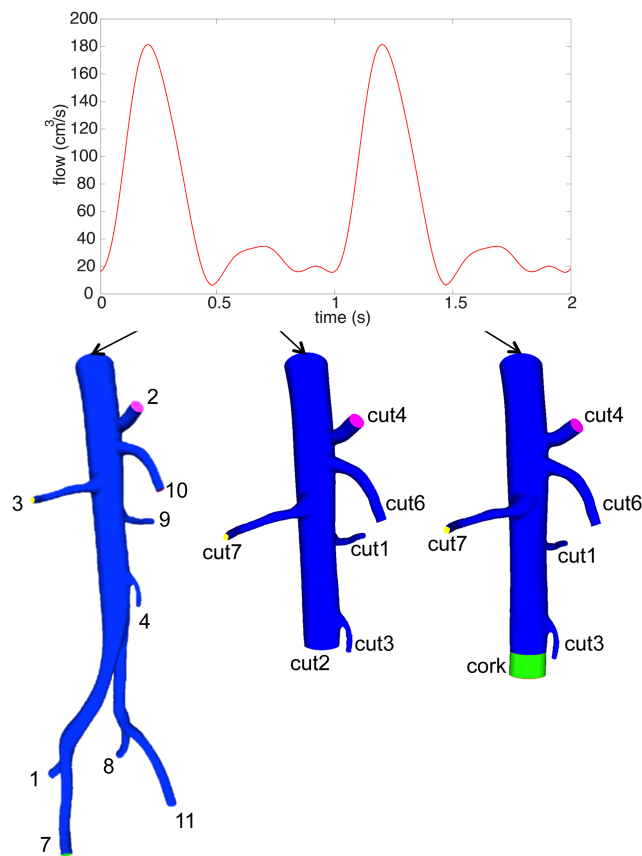

Figure 10: Top: imposed inflow (cm^3/s) shown over two cycles. Below, from left to right: the complete 3D model, the cut 3D model and the cut 3D model with its artificial 3D part tagged “cork”. The outlets are all labeled for future reference.

443 Table 4 contains the values of the proximal and distal resistances, and capacitances

444 for each of the nine outlets of the complete geometrical model. These values have
 445 been set to match clinical measurements [41].

	1	2	3	4	7
R_p	$9.63 \cdot 10^2$	$2.96 \cdot 10^2$	$5.98 \cdot 10^2$	$3.57 \cdot 10^2$	$1.46 \cdot 10^3$
C	$6.21 \cdot 10^{-5}$	$7.67 \cdot 10^{-4}$	$3.80 \cdot 10^{-6}$	$1.40 \cdot 10^{-6}$	$3.03 \cdot 10^{-5}$
R_d	$3.36 \cdot 10^4$	$1.03 \cdot 10^4$	$1.48 \cdot 10^4$	$2.51 \cdot 10^4$	$1.14 \cdot 10^5$
	8	9	10	11	
R_p	$1.08 \cdot 10^3$	$4.86 \cdot 10^2$	$2.70 \cdot 10^1$	$1.59 \cdot 10^3$	
C	$6.91 \cdot 10^{-5}$	$3.70 \cdot 10^{-6}$	$2.13 \cdot 10^{-5}$	$3.09 \cdot 10^{-5}$	
R_d	$4.35 \cdot 10^4$	$1.49 \cdot 10^4$	$1.55 \cdot 10^4$	$1.15 \cdot 10^5$	

Table 4: Reduced model parameters for each outlet of the **reference** model, as labeled in the full model of Figure 10. R_p and R_d in $\text{g cm}^{-4} \text{s}^{-1}$, and C in $\text{g}^{-1} \text{cm}^4 \text{s}^2$.

446 Table 5 contains values of proximal and distal resistances, and capacitances
 447 for each of the six outlets of the cut geometrical model. These reduced model
 448 parameters for the cut abdominal outlet surface (cut2) were not generated from the
 449 ones of the four outlet surfaces of the reference model (labeled 1,7, 8 and 11) as
 450 was done in the previous test case, as this was leading to too inaccurate results.
 451 Instead, the three Windkessel model parameters of this cut outlet were identified
 452 by a Kalman filtering approach based on the flow and pressure tracings from the
 453 reference simulation [34, 35].

	cut1	cut2	cut3	cut4	cut6	cut7
R_p	$4.86 \cdot 10^2$	$8.21 \cdot 10^2$	$3.57 \cdot 10^2$	$2.96 \cdot 10^2$	$2.70 \cdot 10^1$	$5.98 \cdot 10^2$
C	$3.70 \cdot 10^{-6}$	$2.05 \cdot 10^{-4}$	$1.40 \cdot 10^{-6}$	$7.67 \cdot 10^{-4}$	$2.13 \cdot 10^{-5}$	$3.80 \cdot 10^{-4}$
R_d	$1.49 \cdot 10^4$	$2.13 \cdot 10^4$	$2.51 \cdot 10^4$	$1.03 \cdot 10^4$	$1.55 \cdot 10^4$	$1.48 \cdot 10^4$

Table 5: Reduced model parameters for each of the six outlet of the cut model (for the **3D-0D** and **3D-0D-Stab** coupling methods), as labeled in Figure 10. R_p and R_d in $\text{g cm}^{-4} \text{s}^{-1}$, and C in $\text{g}^{-1} \text{cm}^4 \text{s}^2$.

454 Table 6 contains values of proximal and distal resistances, and capacitances for
 455 each of the five outlets of the original part and coefficient α , β and γ for the **3D-3D**
 456 model in the artificial part. The latter were chosen given that the added volumes

457 are such that V , S and L are respectively 1.8 cm^3 , 1.8 cm^2 , and 1 cm . For the
 458 **3D-3D-0D** model, the values are the same, except for the artificial part for which
 459 changes are described at the beginning of the results section.

460

	cut1	cut3	cut4	cut6	cut7		cork
R_p	$4.86 \cdot 10^2$	$3.57 \cdot 10^2$	$2.96 \cdot 10^2$	$2.70 \cdot 10^1$	$5.98 \cdot 10^2$	γ	$1.49 \cdot 10^3$
C	$3.70 \cdot 10^{-6}$	$1.40 \cdot 10^{-6}$	$7.67 \cdot 10^{-4}$	$2.13 \cdot 10^{-5}$	$3.80 \cdot 10^{-6}$	α	$1.13 \cdot 10^{-4}$
R_d	$1.49 \cdot 10^4$	$2.51 \cdot 10^4$	$1.03 \cdot 10^4$	$1.55 \cdot 10^4$	$1.48 \cdot 10^4$	β	$2.60 \cdot 10^{-5}$

Table 6: Reduced model parameters for each outlet of the **3D-3D** coupling model, as labeled in the cut model with “cork” in Figure 10. R_p and R_d in $\text{g cm}^{-4} \text{ s}^{-1}$, and C in $\text{g}^{-1} \text{ cm}^4 \text{ s}^2$, α in $\text{g}^{-1} \text{ cm s}^2$, β in $\text{g}^{-1} \text{ cm s}$, and γ in $\text{g cm}^{-3} \text{ s}^{-1}$.

461 Hemodynamics are compared through the cut abdominal aortic surface of the ref-
 462 erence simulation with the abdominal aortic outlet of the other models. On the left
 463 column of Figure 11, i.e. during forward flow, the velocity field behavior is closer
 464 to the **reference** for the **3D-0D** coupling and thus also for **3D-0D-Stab** method
 465 since the vectors are all pointing outwards. The **3D-3D** approach leads to a flatter
 466 velocity profile. **3D-3D-0D** is in between these two methods. However, during re-
 467 verse flow, the **reference** case concentrates the higher velocity magnitudes on the
 468 exterior part of the surface area. The **3D-0D** coupling method results in high cen-
 469 tral velocity vectors, eventually leading to divergence of the simulation. This time,
 470 the **3D-0D-Stab** and **3D-3D-0D** coupling exhibit some backflow but with a homo-
 471 geneous distribution of velocity vectors on the surface area. The **3D-3D** model is
 472 similar, but with velocity magnitude closer to the average **reference** case.
 473 Figure 12 shows the **Ptot** coupling method results, with spurious radial velocity
 474 vectors, exhibiting here particularly the well-known effect of the total pressure
 475 coupling [22]. In this case the simulation actually diverges.

476

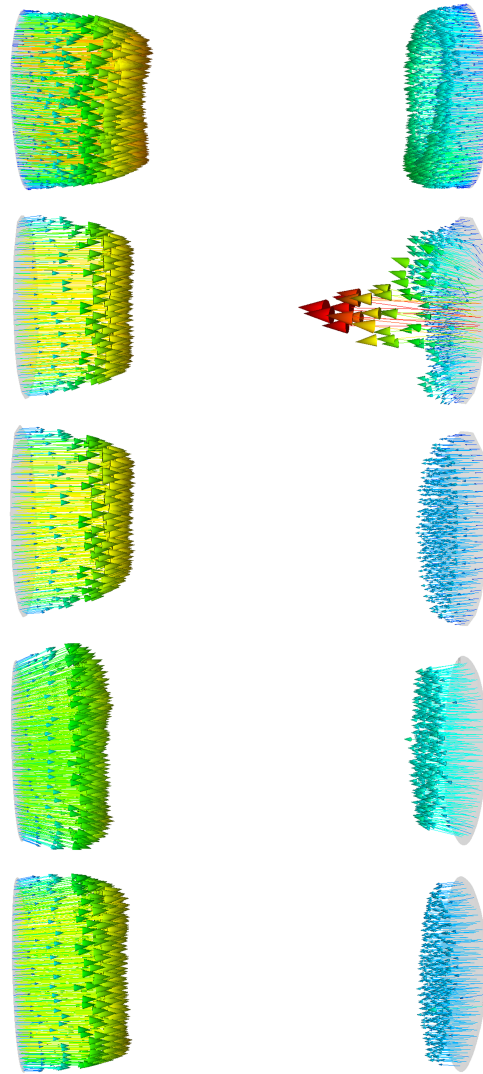

Figure 11: Velocity fields at two different times, $t=0.21s$ (maximal forward inlet flow, left) and $t=0.46s$ (maximal reverse flow at outlet, right) for from top to bottom: **reference**, **3D-0D**, **3D-0D-Stab**, **3D-3D** and **3D-3D-0D** coupling models. Color encodes for velocity magnitude from 0 (blue) to 50 cm/s (red).

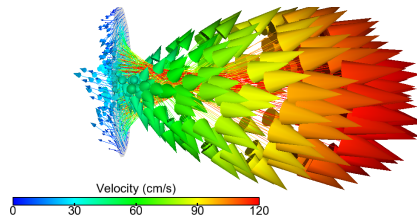

Figure 12: Velocity fields during maximal forward flow with the **3D-0D-Ptot** coupling model.

477 Next, in Figure 13, the resulting time-varying flow rates are compared at the same
 478 surface, between the **3D-0D** , **3D-0D-Stab** , **3D-3D** and **3D-3D-0D** coupling mod-
 479 els. All cases follow a dynamics with a peak in systole followed by a rapid decel-
 480 eration with significant flow reversal and then forward flow again in the last part
 481 of diastole. The curves are neither completely synchronized in time nor match-
 482 ing completely in amplitudes. This time, for the **3D-0D** case the flow rate does
 483 not largely oscillate before the simulation diverges. Moreover the **3D-0D-Stab**
 484 coupling method is disturbing the blood flow behavior, with a flow rate amplitude
 485 lower than the reference one, where maximum flow is lower and minimum flow is
 486 higher than reference flow rate. The **3D-3D** follows closely. The coupling method
 487 that reproduces as best as possible the flow tracing from the reference case is the
 488 **3D-3D-0D** coupling method even if the minimum flow is overestimated.

489 In Figure 14, the corresponding pressure curves are compared: although they
 490 all follow the same typical pressure dynamics of a peak in systole followed by a
 491 smooth decay in diastole, all coupling methods overestimate the reference pres-
 492 sure. They are all shifted in time differently than for the flow rates. The **3D-0D**
 493 case overestimates pressure the least, but it diverges in diastole. For this test case,
 494 the **3D-0D-Stab** method is the furthest from the reference case whereas the **3D-**
 495 **3D-0D** coupling model is the closest. The **3D-3D** coupling approach is in between
 496 in terms of magnitude, but with an additional time shift.

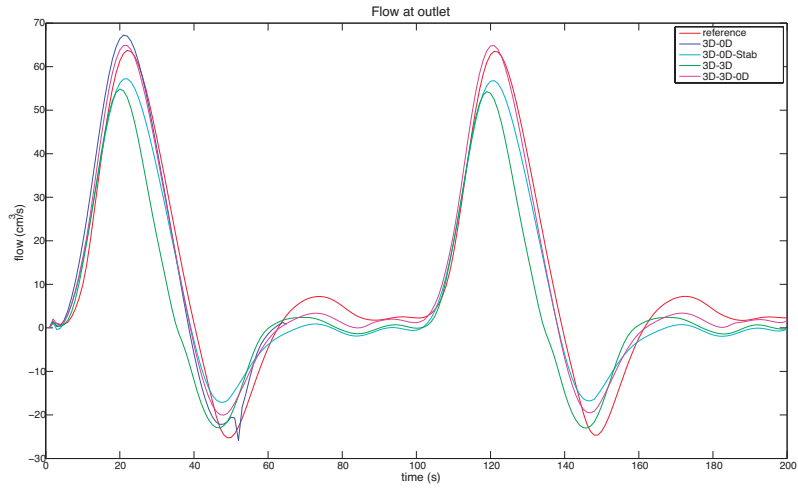

Figure 13: Flow rates over two cardiac cycles at the infrarenal (cut2) coupling interface, with the different coupling methods.

497

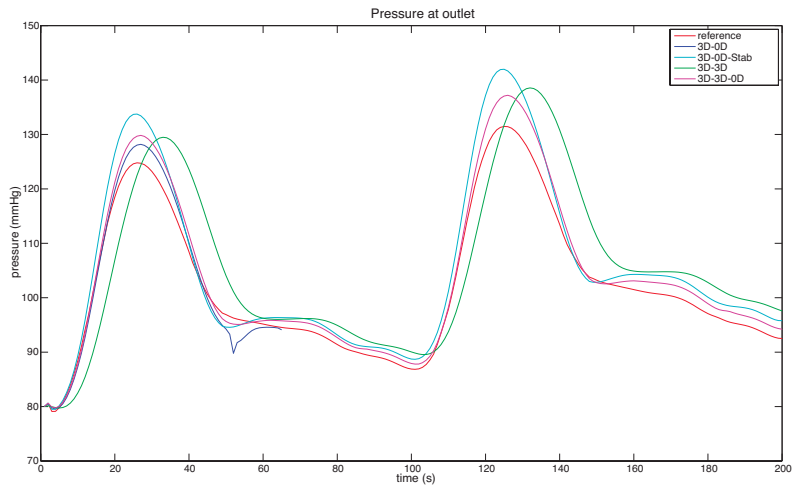

Figure 14: Surface-averaged pressure over two cardiac cycles at the infrarenal (cut2) coupling interface with the different coupling methods.

498 In summary for this case, one can observe that both **3D-0D** and **3D-0D-Ptot** cou-
499 plings lead to divergence of the simulation, due to the negative flow rate at the
500 outlet, although the flow is entering at the inlet. Such a flow rate difference is
501 typical of these abdominal aorta locations [41]. In all the converging cases during
502 back flow, the velocity vectors are all aligned in the same inward direction. The
503 **3D-0D-Stab** , **3D-3D** and **3D-3D-0D** coupling methods presented similarities and
504 differences with the **reference** case, which is the ground truth, **3D-3D-0D** being
505 again the best compromise in this example.

506

507 **4. Discussion and Conclusion**

508 *4.1. Divergence behavior*

509 Different existing methods have been implemented and compared to couple three-
510 dimensional finite element Navier-Stokes simulations to lumped parameter models,
511 and in particular to the three-element Windkessel model. Differences in numerical
512 implementations that might also affect numerical stability (e.g [31] and references
513 therein) are not discussed here, but rather coupling approaches at the continuous
514 level. The first (standard) idea has been to impose weakly that at the coupling inter-
515 face the normal component of the stress tensor is equal to a surface-homogeneous
516 pressure computed from the reduced model. Such a coupling was shown above to
517 lead to an (uncontrolled) convective boundary energy term, potentially destabiliz-
518 ing with flow reversal at the interface. In presence of complex flow at that location,
519 simulations are diverging in the patient-specific examples presented above. This
520 behavior is consistent with other examples from the literature [1, 40]. Note that for
521 the two last patient-specific cases, although the same **3D-0D** coupling was imposed
522 in the full 3D-models, the simulations did not diverge: as the geometry branches
523 off, flow gets more streamlined as observed in [39, 40]. To get rid of this poten-

524 tially destabilizing boundary convective term, the **3D-0D-Ptot** coupling method
525 was also implemented. This coupling approach was considered for example in
526 [5, 22]. Similarly to what [22] observed already for stationary flow in a pipe, ab-
527 normally large radial components of the velocity vectors at the coupling surface
528 were observed during forward flow. Likely because of higher Reynolds numbers
529 and more complex flow in these patient-specific cases, spurious peripheral inward
530 and out of plane velocity vectors were seen, even in case of forward flow. This
531 generated abnormally large in-plane pressure gradient and eventually lead to diver-
532 gence of the simulations when forward flow became higher.

533

534 *4.2. About the convective stabilisation*

535 These two methods highlighted the sensitivity of the simulation stability to the
536 choice of coupling method. It is not a priori possible to predict which simulation
537 will be stable throughout or diverge. Since the first coupling only diverges typi-
538 cally with some inward and non-zero tangential velocity vector or complete back
539 flow at the coupling interface, natural ideas are to enforce the tangential compo-
540 nent to be zero or to even constrain the whole velocity profile. As these have been
541 shown to be non-ideal [29], here the convective **3D-0D-Stab** method was retained.
542 Recall that it only acts when velocity vectors point inwards at the coupling inter-
543 face. It was introduced in [4] for cardiovascular applications with an energetically
544 over-stabilizing effect as discussed above, and successfully tested with a smaller
545 energy-dissipative coefficient (a value of θ of 0.5 or less was found enough to en-
546 sure stability) in [29, 31, 32] in cardiovascular and respiratory contexts. In these
547 papers, without this stabilization the simulations would have diverged. Here the
548 version that exactly annihilates the energetically destabilizing convective term was
549 implemented. It leads in fact to a similar stabilizing behavior. The present re-

550 sults highlight the robustness of this method under different conditions of complex
551 and back flows. However such a coupling involves enforcing an ad-hoc inhomogeneous
552 normal stress over the interface area and in practice generally induces an
553 over-killing of the inward velocity vectors. Besides, as noted by [36], this leads to
554 a weak formulation that is not consistent with the original strong boundary condition
555 of the reduced model coupling. A consistent formulation (with a value of θ
556 of one) has been proposed by [20] in respiratory mechanics (see this reference for
557 earlier references about imposition of total momentum flux) but it requires to also
558 prescribe the convective term and thus to know the velocity vectors at the coupling
559 boundary or to make some further assumption on the velocity profile at the boundary
560 [20, 23]. The convective stabilization with $\theta = 1$ resulted in single tube cases
561 in a flatter velocity profile than in their total momentum flux case. It is interesting
562 to note that in respiratory applications for which the back flow is very significant
563 (whole expiration phase), the necessity to stabilize the convective term one way or
564 another was found crucial [23, 26, 32].

565

566 *4.3. Discussion on the modified Navier-Stokes method, its advantages and limits*

567 One of our main aims was thus to develop a new three-dimensional finite element
568 coupling method where reduced model parameters were three-dimensionally distributed
569 in a modified Navier-Stokes equation into a small outer portion. The goal
570 was to obtain a blood flow behavior as close as possible to a **3D-0D** coupling into
571 an extended geometrical model with more branches. From a theoretical point of
572 view, this approach has the advantage that it does not necessitate a coupling condition
573 at the interface: it thus does not enforce the normal component of the stress to
574 be homogeneous as in the **3D-0D** method or inhomogeneous in an ad-hoc way as in
575 the **3D-0D-Stab** method. Another advantage is that it generates an energy balance

576 that is similar to the **3D-0D** method, but, if the distal boundary of the modified part
577 is set to zero velocity (as was done in the **3D-3D** simulations), it does not include
578 the potentially destabilizing convective boundary term. If this distal velocity is not
579 zero (as was the case in the **3D-3D-0D** simulations), the velocity field is damped
580 and smoothed by the modified portion before it reaches the boundary, so it does
581 not develop instabilities in practice.

582 Numerically, as a general trend, the results suggest that the **3D-0D-Stab** coupling
583 method is more accurately reproducing forward flow whereas during deceleration
584 or reverse flow it is less invasive to use the three-dimensional coupling **3D-3D** ap-
585 proach than the robust **3D-0D-Stab** model. An excellent compromise was reached
586 by the **3D-3D-0D** method, a hybrid method which regularizes the flow in an ar-
587 tificial portion, with a small dissipative term, representing a small fraction of the
588 proximal resistance. It effectively stabilized the simulations, without significantly
589 affecting forward flow but allowing more freely inward velocity vectors than the
590 **3D-0D-Stab** method. Regarding pressure and flow tracings at the coupling inter-
591 faces of the three patient-specific cases, all coupling methods could reproduce the
592 general temporal dynamics, unless they diverged. However, quantitative pressure
593 and flow differences could be observed. In fact, in biomedical applications, the ex-
594 isting coupling methods and the ones developed in this article all involve tuning of
595 the distal parameters in order to be as coherent as possible to clinical hemodynam-
596 ics measurements [43]. Such tuning was not the focus of this work, and is matter of
597 intense recent research (e.g [1, 7, 13, 24, 34, 35, 38, 39]). Here, when the reference
598 model (extended model with Windkessel reduced models at its ends) was available,
599 it was quite simple to deduce or automatically tune the corresponding Windkessel
600 model at the coupling interface of the cut model. This made sure that the **3D-0D**
601 and **3D-0D-Stab** results were close to the **reference** case. However, such equiv-
602 alence or tuning was less obvious to do for the new **3D-3D** parameters (α , β and

603 γ): a better match of the pressure and flow waveforms could be achieved by man-
604 ually tuning these parameters, but we thought it would make more sense to present
605 the results with the most straightforward parameterization. Actually in general the
606 reference model would not be available (otherwise it would be used without cut-
607 ting) and the modified Navier-Stokes parameters (in its original or hybrid version)
608 would be tuned in order to match clinical hemodynamics measurements instead of
609 matching reduced model parameters R_p , C and R_d . This approach is not developed
610 at this time and could be part of future work. Another important question that was
611 not addressed in detail here is the length of the artificial domain. Size should not of
612 course be too large to avoid unnecessary additional computational cost. If it is too
613 small, pressure and velocity change too abruptly (**3D-3D**) or the velocity field is
614 not regularized enough before hitting the outlet (**3D-3D-0D**). We have not carried
615 out an extensive sensitivity analysis on the subject, but we noticed that multiplying
616 the cork volume of the presented results by a factor two did not affect the numerical
617 stability of the solution.

618

619 *4.4. Comparison between cut and reference models*

620 Interestingly, several methods lead to more similar results between each other than
621 compared to the non-cut reference model. This is particularly true when the down-
622 stream part is geometrically different than the upstream, as was the case of the LPA
623 in the child pulmonary example. The distribution of flow rates among the different
624 downstream vessels can also affect the flow in the non-cut upstream region. This
625 highlights the importance of including enough downstream geometry to not affect
626 the area of interest in the three-dimensional part in biomedical applications [1, 39].

627

628 *4.5. Possible extension of the work*

629 Finally, this **3D-3D** method could be extended to a more extensive lumped pa-
630 rameter model through the β term. The latter could include a distal pressure, rep-
631 resenting the link with the rest of the reduced model. Furthermore, it would be
632 interesting to implement a space-varying γ parameter. This dissipative term in the
633 Navier-Stokes equation is known to regularize the velocity profile to a plug-like
634 profile (like at the interface with a porous medium), which helps here to stabilize
635 the simulation but is also responsible for a significant impact on the velocity field
636 at the interface. The coupling approach would be less invasive in particular dur-
637 ing forward flow if this parameter was changing more smoothly. This is probably
638 why the **3D-3D-0D** was found to be the best compromise between robustness and
639 non-invasiveness.

640 *Acknowledgments.* This work was supported by the Leducq Foundation as part of
641 the Transatlantic Network of Excellence for Cardiovascular Research "Multi-scale
642 modeling of single ventricle hearts for clinical decision support", and Associated
643 team Cardio INRIA grant.

644 **References:**

- 645 [1] Arbia, G., Corsini, C., Baker, C., Pennati, G., Hsia, T.Y., Vignon-Clementel,
646 I.E., for MOCHA: Pulmonary hemodynamics simulations before stage 2 sin-
647 gle ventricle surgery: patient-specific parameter identification and clinical
648 data assessment. *Cardiovascular Engineering and Technology* **6**(3), 268–280
649 (2015). DOI 10.1007/s13239-015-0212-3
- 650 [2] Arbia, G., Corsini, C., Esmaily Moghadam, M., Marsden, A.L., Migliavacca,
651 F., Pennati, G., Hsia, T.Y., Vignon-Clementel, I.E., for MOCHA: Numerical

- 652 blood flow simulation in surgical corrections: what do we need for an accurate
653 analysis? *Journal of Surgical Research* **186**(1), 44–55 (2014)
- 654 [3] Baretta, A., Corsini, C., Marsden, A.L., Vignon-Clementel, I.E., Hsia, T.Y.,
655 Dubini, G., Migliavacca, F., Pennati, G., for MOCHA: Respiratory effects
656 on hemodynamics in patient-specific CFD models of the Fontan circulation
657 under exercise conditions. *European Journal of Mechanics B-Fluids* **35**, 61–
658 69 (2012). DOI 10.1016/j.euromechflu.2012.01.012. URL <GotoISI>://
659 WOS:000306039700010
- 660 [4] Bazilevs, Y., Gohean, J.R., Hughes, T.J.R., Moser, R.D., Zhang, Y.: Patient-
661 specific isogeometric fluid-structure interaction analysis of thoracic aortic
662 blood flow due to implantation of the Jarvik 2000 left ventricular assist de-
663 vice. *Computer Methods in Applied Mechanics and Engineering* **198**(45-
664 46), 3534–3550 (2009). DOI 10.1016/j.cma.2009.04.015. URL <GotoISI>:
665 //WOS:000270702500004
- 666 [5] Begue, C., Conca, C., Murat, F., Pironneau, O.: Les équations de Stokes et
667 de Navier-Stokes avec des conditions aux limites sur la pression. *Seminaire*
668 *College de France* (1988)
- 669 [6] Bertoglio, C., Caiazzo, A.: A tangential regularization method for backflow
670 stabilization in hemodynamics. *Journal of Computational Physics* **261**, 162–
671 171 (2014)
- 672 [7] Bertoglio, C., Moireau, P., Gerbeau, J.F.: Sequential parameter estimation
673 for fluid–structure problems: Application to hemodynamics. *International*
674 *Journal for Numerical Methods in Biomedical Engineering* **28**(4), 434–455
675 (2012)

- 676 [8] Blanco, P., Watanabe, S., Feijóo, R.: Identification of vascular terri-
677 tory resistances in one-dimensional hemodynamics simulations. *Journal*
678 *of Biomechanics* **45**(12), 2066 – 2073 (2012). DOI [http://dx.doi.org/10.](http://dx.doi.org/10.1016/j.jbiomech.2012.06.002)
679 [1016/j.jbiomech.2012.06.002](http://dx.doi.org/10.1016/j.jbiomech.2012.06.002). URL [http://www.sciencedirect.com/](http://www.sciencedirect.com/science/article/pii/S002192901200334X)
680 [science/article/pii/S002192901200334X](http://www.sciencedirect.com/science/article/pii/S002192901200334X)
- 681 [9] Blanco, P.J., Deparis, S., Malossi, A.C.I.: On the continuity of mean to-
682 tal normal stress in geometrical multiscale cardiovascular problems. *Jour-*
683 *nal of Computational Physics* **251**(0), 136–155 (2013). DOI [http://dx.doi.](http://dx.doi.org/10.1016/j.jcp.2013.05.037)
684 [org/10.1016/j.jcp.2013.05.037](http://dx.doi.org/10.1016/j.jcp.2013.05.037). URL [http://www.sciencedirect.com/](http://www.sciencedirect.com/science/article/pii/S0021999113004038)
685 [science/article/pii/S0021999113004038](http://www.sciencedirect.com/science/article/pii/S0021999113004038)
- 686 [10] Blanco, P.J., Feijoo, R.A.: A dimensionally-heterogeneous closed-loop
687 model for the cardiovascular system and its applications. *Medical Engineer-*
688 *ing and Physics* **35**(5), 652–667 (2013). DOI [10.1016/j.medengphy.2012.07.](https://doi.org/10.1016/j.medengphy.2012.07.011)
689 [011](https://doi.org/10.1016/j.medengphy.2012.07.011). URL [http://www.isinet.com/doi/10.1016/j.medengphy.2012.07.](http://www.isinet.com/doi/10.1016/j.medengphy.2012.07.011)
[011](http://www.isinet.com/doi/10.1016/j.medengphy.2012.07.011). URL <GotoISI>://WOS:000318457200012
- 690 [11] Bruneau, C.H., Fabrie, P.: Effective downstream boundary conditions for in-
691 compressible Navier–Stokes equations. *International Journal for Numerical*
692 *Methods in Fluids* **19**(8), 693–705 (1994)
- 693 [12] Bruneau, C.H., Fabrie, P.: New efficient boundary conditions for incompress-
694 ible Navier–Stokes equations: a well-posedness result. *RAIRO-Modélisation*
695 *mathématique et analyse numérique* **30**(7), 815–840 (1996)
- 696 [13] Corsini, C., Baker, C., Kung, E., Schievano, S., Arbia, G., Baretta, A.,
697 Biglino, G., Migliavacca, F., Dubini, G., Pennati, G., Marsden, A., Vignon-
698 Clementel, I., Taylor, A., Hsia, T.Y., Dorfman, A., for MOCHA: An inte-
699 grated approach to patient-specific predictive modeling for single ventricle

- 700 heart palliation. *Computer Methods in Biomechanics and Biomedical Engineering* pp. 1–18 (2013). DOI 10.1080/10255842.2012.758254. URL <http://www.tandfonline.com/doi/abs/10.1080/10255842.2012.758254>
- 701
- 702
- 703 [14] Dobroserdova, T., Olshanskii, M.: A finite element solver and energy stable
704 coupling for 3D and 1D fluid models. *Computer Methods in Applied Me-*
705 *chanics and Engineering* **259**, 166–176 (2013). DOI 10.1016/j.cma.2013.03.
706 018
- 707 [15] Formaggia, L., Gerbeau, J.F., Nobile, F., Quarteroni, A.: On the cou-
708 pling of 3D and 1D Navier-Stokes equations for flow problems in com-
709 pliant vessels. *Computer Methods in Applied Mechanics and Engineering*
710 **191**(6-7), 561–582 (2001). DOI [http://dx.doi.org/10.1016/S0045-7825\(01\)](http://dx.doi.org/10.1016/S0045-7825(01)00302-4)
711 [00302-4](http://dx.doi.org/10.1016/S0045-7825(01)00302-4). URL [http://www.sciencedirect.com/science/article/
712 pii/S0045782501003024](http://www.sciencedirect.com/science/article/pii/S0045782501003024)
- 713 [16] Formaggia, L., Moura, A., Nobile, F.: On the stability of the coupling of 3D
714 and 1D fluid-structure interaction models for blood flow simulations. *ESAIM:
715 Mathematical Modelling and Numerical Analysis* **41**, 743–769 (2007). DOI
716 10.1051/m2an:2007039
- 717 [17] Formaggia, L., Quarteroni, A., Vergara, C.: On the physical consistency be-
718 tween three-dimensional and one-dimensional models in haemodynamics.
719 *Journal of Computational Physics* **244**, 97–112 (2013). DOI 10.1016/j.jcp.
720 2012.08.001. URL <http://www.isi.edu/WOS:000319456900007>
- 721 [18] Fouchet-Incaux, J.: Artificial boundaries and formulations for the incom-
722 pressible Navier–Stokes equations: applications to air and blood flows.
723 *SeMA Journal* **64**(1), 1–40 (2014)

- 724 [19] Frank, O.: Die Grundform Des Arteriellen Pulses. *Zeitung für Biologie* **37**,
725 483–586 (1899)
- 726 [20] Gravemeier, V., Comerford, A., Yoshihara, L., Ismail, M., Wall, W.A.: A
727 novel formulation for neumann inflow boundary conditions in biomechan-
728 ics. *International Journal for Numerical Methods in Biomedical Engineering*
729 **28**(5), 560–573 (2012). DOI 10.1002/cnm.1490. URL <GotoISI>://WOS:
730 000303441300005
- 731 [21] Guibert, R., Mcleod, K., Caiazzo, A., Mansi, T., Fernández, M.Á., Serme-
732 sant, M., Pennec, X., Vignon-Clementel, I., Boudjemline, Y., Gerbeau, J.F.:
733 Group-wise Construction of Reduced Models for Understanding and Char-
734 acterization of Pulmonary Blood Flows from Medical Images. *Medical Im-
735 age Analysis* **18**(1), 63–82 (2013). DOI 10.1016/j.media.2013.09.003. URL
736 <http://hal.inria.fr/hal-00874545>
- 737 [22] Heywood, J.G., Rannacher, R., Turek, S.: Artificial boundaries and flux and
738 pressure conditions for the incompressible Navier-Stokes equations. *Interna-
739 tional Journal for Numerical Methods in Fluids* **22**(5), 325–352 (1996). DOI
740 10.1002/(sici)1097-0363(19960315)22:5<325::aid-fld307>3.0.co;2-y. URL
741 <GotoISI>://WOS:A1996TY25800001
- 742 [23] Ismail, M., Gravemeier, V., Comerford, A., Wall, W.A.: A stable approach
743 for coupling multidimensional cardiovascular and pulmonary networks based
744 on a novel pressure-flow rate or pressure-only neumann boundary condition
745 formulation. *International Journal For Numerical Methods in Biomedical
746 Engineering* **30**(4), 447–469 (2014). DOI 10.1002/cnm.2611
- 747 [24] Ismail, M., Wall, W.A., Gee, M.W.: Adjoint-based inverse analysis of wind-
748 kessel parameters for patient-specific vascular models. *Journal of Computa-*

- 749 tional Physics **244**, 113–130 (2013). DOI 10.1016/j.jcp.2012.10.028. URL
750 <GotoISI>://WOS:000319456900008
- 751 [25] Kim, H.J., Vignon-Clementel, I.E., Figueroa, C.A., Jansen, K.E., Taylor,
752 C.A.: Developing computational methods for three-dimensional finite ele-
753 ment simulations of coronary blood flow. *Finite Elements in Analysis and*
754 *Design* **46**(6), 514–525 (2010). DOI 10.1016/j.finel.2010.01.007. URL
755 <GotoISI>://WOS:000276019800007
- 756 [26] Kuprat, A.P., Kabilan, S., Carson, J.P., Corley, R.A., Einstein, D.R.: A
757 bidirectional coupling procedure applied to multiscale respiratory modeling.
758 *Multi-scale Modeling and Simulation of Biological Systems* **244**(0), 148–167
759 (2013). URL [http://www.sciencedirect.com/science/article/
760 pii/S0021999112006225](http://www.sciencedirect.com/science/article/pii/S0021999112006225)
- 761 [27] Maury, B., Meunie, N., Soualah, A., Vial, L.: Outlet dissipative conditions
762 for air flow in the bronchial tree. *ESAIM: Proc.* **14**, 201–212 (2005). DOI 10.
763 1051/proc:2005015. URL <http://dx.doi.org/10.1051/proc:2005015>
- 764 [28] Migliavacca, F., Balossino, R., Pennati, G., Dubini, G., Hsia, T.Y., de Leval,
765 M.R., Bove, E.L.: Multiscale modelling in biofluidynamics: Applica-
766 tion to reconstructive paediatric cardiac surgery. *Journal of Biomechan-*
767 *ics* **39**(6), 1010–1020 (2006). DOI 10.1016/j.jbiomech.2005.02.021. URL
768 <GotoISI>://WOS:000236834900004
- 769 [29] Moghadam, M.E., Bazilevs, Y., Hsia, T.Y., Vignon-Clementel, I.E., Mars-
770 den, A.L., for MOCHA: A comparison of outlet boundary treatments for
771 prevention of backflow divergence with relevance to blood flow simula-
772 tions. *Computational Mechanics* **48**(3), 277–291 (2011). DOI 10.1007/
773 s00466-011-0599-0. URL <GotoISI>://WOS:000294346200004

- 774 [30] Moghadam, M.E., Migliavacca, F., Vignon-Clementel, I.E., Hsia, T.Y., Mars-
775 den, A.L., for MOCHA: Optimization of shunt placement for the Nor-
776 wood surgery using multi-domain modeling. *Journal of Biomechanical*
777 *Engineering-Transactions of the Asme* **134**(5) (2012). DOI 10.1115/1.
778 4006814. URL <GotoISI>://WOS:000305793100002
- 779 [31] Moghadam, M.E., Vignon-Clementel, I.E., Figliola, R., Marsden, A.L., for
780 MOCHA: A modular numerical method for implicit 0D/3D coupling in car-
781 diovascular finite element simulations. *Journal of Computational Physics*
782 **244**, 63–79 (2013). DOI 10.1016/j.jcp.2012.07.035. URL <GotoISI>:
783 //WOS:000319456900005
- 784 [32] Oakes, J., Marsden, A., Grandmont, C., Shadden, S., Darquenne, C., Vignon-
785 Clementel, I.: Airflow and Particle Deposition Simulations in Health and Em-
786 physema: From In Vivo to In Silico Animal Experiments. *Annals of Biomed-*
787 *ical Engineering* **42**(4), 899–914 (2014). DOI 10.1007/s10439-013-0954-8.
788 URL <http://hal.inria.fr/hal-00916348>
- 789 [33] Oshima, M., Torii, R., Tokuda, S., Yamada, S., Koizumi, A.: Patient-specific
790 modeling and multi-scale blood simulation for computational hemodynamic
791 study on the human cerebrovascular system. *Current Pharmaceutical Biotech-*
792 *nology* **13**(11), 2153–2165 (2012)
- 793 [34] Pant, S., Fabrèges, B., Gerbeau, J.F., Vignon-Clementel, I.: A methodologi-
794 cal paradigm for patient-specific multi-scale CFD simulations: from clinical
795 measurements to parameter estimates for individual analysis. *International*
796 *journal for numerical methods in biomedical engineering* **30**(12), 1614–1648
797 (2014)
- 798 [35] Pant, S., Fabrèges, B., Gerbeau, J.F., Vignon-Clementel, I.: A multiscale

- 799 filtering-based parameter estimation method for patient-specific coarctation
800 simulations in rest and exercise. In: O. Camara, T. Mansi, M. Pop,
801 K. Rhode, M. Sermesant, A. Young (eds.) *Statistical Atlases and Compu-*
802 *tational Models of the Heart. Imaging and Modelling Challenges, Lecture*
803 *Notes in Computer Science*, vol. 8330, pp. 102–109. Springer Berlin Heidel-
804 berg (2014). DOI 10.1007/978-3-642-54268-8_12. URL [http://dx.doi.](http://dx.doi.org/10.1007/978-3-642-54268-8_12)
805 [org/10.1007/978-3-642-54268-8_12](http://dx.doi.org/10.1007/978-3-642-54268-8_12)
- 806 [36] Porpora, A., Zunino, P., Vergara, C., Piccinelli, M.: Numerical treatment
807 of boundary conditions to replace lateral branches in hemodynamics. *Inter-*
808 *national Journal for Numerical Methods in Biomedical Engineering* **28**(12),
809 1165–1183 (2012). DOI 10.1002/cnm.2488. URL <http://www.isinet.com/doi/10.1002/cnm.2488>. URL <GotoISI>://WOS:
810 000311975400001
- 811 [37] Prasad, A., To, L.K., Gorrepati, M.L., Zarins, C.K., Figueroa, C.A.: Compu-
812 tational analysis of stresses acting on intermodular junctions in thoracic aortic
813 endografts. *Journal of Endovascular Therapy* **18**(4), 559–568 (2011). URL
814 <GotoISI>://WOS:000294212500020
- 815 [38] Spilker, R., Taylor, C.: Tuning multidomain hemodynamic simulations to
816 match physiological measurements. *Annals of Biomedical Engineering*
817 **38**(8), 2635–2648 (2010). DOI 10.1007/s10439-010-0011-9. URL [http:](http://dx.doi.org/10.1007/s10439-010-0011-9)
818 [//dx.doi.org/10.1007/s10439-010-0011-9](http://dx.doi.org/10.1007/s10439-010-0011-9)
- 819 [39] Troianowski, G., Taylor, C.A., Feinstein, J.A., Vignon-Clementel, I.E.:
820 Three-dimensional simulations in glenn patients: clinically based boundary
821 conditions, hemodynamic results and sensitivity to input data. *Journal of*
822 *Biomechanical Engineering* **133**, 111,006 (2011)

- 823 [40] Vignon-Clementel, I.: A coupled multidomain method for computational
824 modeling of blood flow. Ph.D. thesis, Stanford (2006)
- 825 [41] Vignon-Clementel, I.E., Figueroa, C.A., Jansen, K.E., Taylor, C.A.: Outflow
826 boundary conditions for three-dimensional finite element modeling of blood
827 flow and pressure in arteries. *Computer Methods in Applied Mechanics and*
828 *Engineering* **195**(29-32), 3776–3796 (2006). DOI 10.1016/j.cma.2005.04.
829 014. URL <GotoISI>://WOS:000237754700012
- 830 [42] Vignon-Clementel, I.E., Figueroa, C.A., Jansen, K.E., Taylor, C.A.: Out-
831 flow boundary conditions for 3D simulations of non-periodic blood flow
832 and pressure fields in deformable arteries. *Computer Methods in Biome-*
833 *chanics and Biomedical Engineering* **13**(5), 625–640 (2010). DOI 10.1080/
834 10255840903413565. URL <GotoISI>://WOS:000281851500012
- 835 [43] Vignon-Clementel, I.E., Marsden, A.L., Feinstein, J.A.: A primer on compu-
836 tational simulation in congenital heart disease for the clinician. *Progress in*
837 *Pediatric Cardiology* **30**(1), 3–13 (2010)
- 838 [44] Yang, W., Vignon-Clementel, I.E., Troianowski, G., Reddy, V.M., Fein-
839 stein, J.A., Marsden, A.L.: Hepatic blood flow distribution and performance
840 in conventional and novel Y-graft Fontan geometries: A case series com-
841 putational fluid dynamics study. *Journal of Thoracic and Cardiovascular*
842 *Surgery* **143**(5), 1086–1097 (2012). DOI 10.1016/j.jtcvs.2011.06.042. URL
843 <GotoISI>://WOS:000302810700015