



HAL
open science

A Simple Compensation Method for the Accurate Measurement of Magnetic Losses With a Single Strip Tester

Olivier de La Barrière, C Ragusa, M Khan, C Appino, F Fiorillo, F Mazaleyrat

► **To cite this version:**

Olivier de La Barrière, C Ragusa, M Khan, C Appino, F Fiorillo, et al.. A Simple Compensation Method for the Accurate Measurement of Magnetic Losses With a Single Strip Tester. IEEE Transactions on Magnetics, 2016, 52 (5), 10.1109/TMAG.2016.2527829 . hal-01327663

HAL Id: hal-01327663

<https://hal.science/hal-01327663>

Submitted on 6 Jun 2016

HAL is a multi-disciplinary open access archive for the deposit and dissemination of scientific research documents, whether they are published or not. The documents may come from teaching and research institutions in France or abroad, or from public or private research centers.

L'archive ouverte pluridisciplinaire **HAL**, est destinée au dépôt et à la diffusion de documents scientifiques de niveau recherche, publiés ou non, émanant des établissements d'enseignement et de recherche français ou étrangers, des laboratoires publics ou privés.

A simple compensation method for the accurate measurement of magnetic losses with a single strip tester

O. de la Barrière¹, C. Ragusa², M. Khan², C. Appino³, F. Fiorillo³, F. Mazaleyrat¹

¹SATIE, CNRS, UniverSud, 61 av du President Wilson, F-94230 Cachan, France

²Dipart. Energia, Politecnico di Torino, C.so Duca degli Abruzzi 24, 10129 Torino, Italy

³Nanoscience and Materials Division, Istituto Nazionale di Ricerca Metrologica (INRIM), Torino, Italy

We present a new method for the accurate characterization of soft magnetic sheets using a permeameter based on the precise compensation of the magnetomotive force (MMF) drop in the flux-closing yoke. It has been developed in order to overcome the systematic uncertainty affecting the value of the magnetic fieldstrength in single sheet testers when obtained, according to the standards, through the measurement of the magnetizing current. This phenomenon is more critical for high permeability materials, because of the reduced MMF drop across the sample. While additional sensors and auxiliary windings have been proposed in the literature, a novel approach is demonstrated here, based on the use of the permeameter upper half yoke as the MMF drop sensor and of an auxiliary winding on the lower half yoke, implementing compensation. This solution, dispensing one from dealing with the usually small signal levels of the conventional MMF drop sensors (e.g. Chattock coils), provides best results with the introduction of wedge-shaped magnetic poles, in order to accurately define the magnetic path length. The method is validated by measurements of power loss, apparent power, and hysteresis cycles on non-oriented and grain-oriented Fe-Si steel sheets, which are compared with local measurements performed on the same samples using *H*-coil and *B*-coil across a uniformly magnetized region.

Index Terms—Magnetic loss, hysteresis cycle, compensated permeameter, apparent power.

I. INTRODUCTION

THE PROPER design of electrical machines and electromagnetic devices requires an accurate prediction of iron loss. Indeed, in modern embedded applications such as hybrid or electric vehicles [1][2], the best compromise must be found between the machine efficiency [3][4] and torque density [5]. But any predictive model starts from a proper material characterization [6][7]. The standard testing technique of soft magnetic steel sheets is based on the use of the Epstein test frame [8]. It shows good reproducibility, demonstrated by inter-laboratory comparisons of power loss and apparent power measurements [9]. However, this method besides requiring tedious preparation of the samples, is inevitably affected by appreciable systematic deviations (up to about 10 % at high inductions) from the true values of the measured quantities, as obtained, for example, by accurate measurements using *H*-coils [9][10][11]. But the *H*-coil method requires the integration of low-level signals and is hardly acceptable in the industrial practice. Increasing interest is therefore attached, at present time, to the Single Sheet Testing (SST) method, applied according to the pertaining IEC Standard [12][13], because of the convenient use of wide lamination samples. The SST method does not require stress relief of samples upon cutting, can be directly applied to the domain-refined high-grade grain-oriented materials, and shows good reproducibility of measurements [9] [14]. Consequently, there is demand by industry for including SST reference values in the material specification standards. With the SST arrangement, where the sheet sample is inserted in a double-C laminated yoke, the magnetic fieldstrength is calculated using the measured magnetizing current and defined magnetic path length ($l_m = 0.45$ m) is adopted. A major problem here is that the magnetomotive force (MMF) drop in the flux-closing yokes may not be negligible with respect to

the one across the sample, especially with high-permeability materials. This can lead to overestimated magnetic field values. At the same time, the yoke itself can provide a certain contribution to the measured loss, depending on its manufacture and the possible existence of interlaminar eddy currents at the pole faces [15].

One way to overcome this difficulty is, as discussed in [16], one of compensating the drop of the MMF in the yokes of the permeameter by an auxiliary magnetizing winding. This is driven by a Chattock coil, placed over the measuring sample region of length l_m and a very high-gain amplifier, implementing a feedback control on the auxiliary current, such as to compensate the MMF drop outside the length l_m [16]. Like all the *H*-coil measurements, this method has a weak point in the necessity of handling small signal levels.

In this paper, we consider a single strip double-C yoke permeameter, applied to annealed Epstein samples, where a new compensation method, simpler and more effective than previous literature solutions [16], is implemented. Epstein strip samples are used in the present experiments for practical convenience, but the method could be easily adapted to standard SST permeameters. The idea is one of using the upper half of the yoke as a zero MMF indicator and the lower half for accommodating the compensation circuit. It is a simple measuring arrangement, where the signal to be controlled is relatively large and much easier to handle than the weak and noise-prone signal generated by a Chattock coil. As a further advantage, there is no geometrical discontinuity in the magnetizing winding, as required instead, with ensuing inhomogeneity of the applied field, by the insertion of the Chattock coil [16]. The method is validated by comparison with accurate measurements performed upon a relatively restricted median region of the strip sample by the *H*-coil method. Non-oriented (NO) and high-permeability grain-oriented (GO) Fe-Si samples have been tested, with very good

70 agreement between the results obtained with the magnetizing
 71 current and those obtained by localized H and B coils.

72 II. THE COMPENSATED PERMEAMETER

73 In this section we describe the geometry of the system and
 74 the circuit for the compensation of the MMF drop.

75 A. System geometry and magnetic path length

76 The sample is a conventional annealed Epstein strip. The
 77 induction derivative is measured by means of a 500-turn
 78 mm long pickup coil placed at the center of the strip. Inside
 79 the B -coil, a many-turn calibrated flat H -coil (1 mm thick
 80 turn-area $2.25 \cdot 10^{-2} \text{ m}^2$) of same length is placed upon the
 81 sample surface (see

82 Fig. 1). The H -coil provides, after integration of the
 83 measured voltage, the tangential field upon the measuring
 84 area. Since in the measuring region the applied field and the
 85 induction are verified to be highly uniform, tangential field
 86 and internal field are bound to coincide. The measured local
 87 loss is thus identified with the true loss figure of the material,
 88 that is, the reference quantity for the results obtained with the
 89 compensated permeameter.

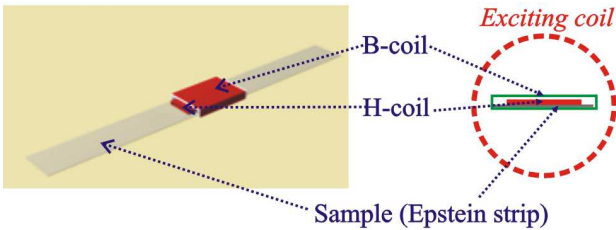

90
 91
 92 Fig. 1 - Sample (Epstein strip), with enwrapping B -coil and tangential H -coil
 93 (3D view and front view).

by which maximum uniformity of the applied field across the
 whole distance L_i is obtained ([11], p. 109).

According to Ampère's law, the magnetomotive force NI
 generated by a current I flowing into the N -turn solenoid is
 related to the magnetic field H along a closed path L by the
 equation

$$N \cdot I = \oint_L H \cdot dl. \quad (1)$$

If a method is found by which the drop of the MMF in the
 flux-closing yoke is made either negligible or fully
 compensated, (1) simply becomes $N \cdot I = H \cdot L_s$, where L_s is
 the length of the mean magnetic flux path in the sample. L_s
 has value intermediate between L_i , the distance between the pole
 faces, and L_o , the width of the permeameter (Fig. 2b), as the
 obvious result of flux channeling from the sample into the
 yokes (see Fig. 3a). It is actually not well defined and it
 depends on the magnetization level in the sheet sample. It will
 appreciably change on approaching the material saturation.

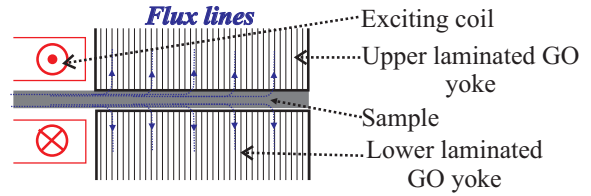

(a) Standard configuration.

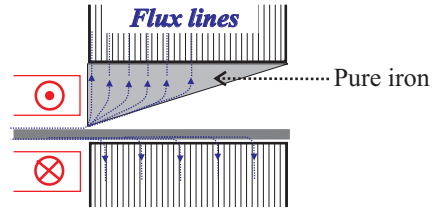

(b) Modified configuration.

Fig. 3 - Defining the magnetic flux path length in the sample.

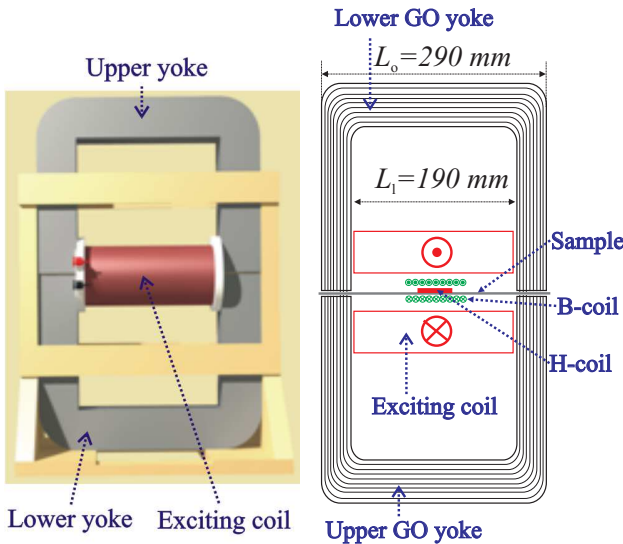

Fig. 2 - a) 3D view of the permeameter. b) 2D view of magnetizer, exciting
 circuit, and measuring coils.

94 The developed permeameter, shown in Fig. 2, consists of
 95 double-C laminated yoke of $50 \text{ mm} \times 50 \text{ mm}$ cross-section
 96 area, made of 0.30 mm thick high-permeability GO strips.
 97 uniformly wound magnetizing solenoid covers the distance
 98 $= 190 \text{ mm}$ between the pole faces of the yoke. It is endowed
 99 with series connected additional narrow windings at its ends

116 We wish to impose a flux path such that the length L_s
 117 coincides with the distance between the pole faces L_i . To this
 118 end, the following modification of the upper yoke is proposed.
 119 Two identical wedge-shaped pure iron poles are placed
 120 beneath the two limbs of the upper yoke, as shown in Fig. 3b
 121 and Fig. 5, with the contact lines between the sheet surface
 122 and the poles placed exactly at the distance L_i . As discussed in
 123 the following Section, this is expected to force, under the
 124 action of a feedback system employing auxiliary windings on
 125 the yokes, the flux path length in the sample to be equal to L_i .
 126 Under these conditions, the magnetic field H in the sample
 127 will be obtained according to the relation

$$N \cdot I = H \cdot L_i. \quad (2)$$

independent of the way the flux lines enter the lower yoke.

B. The principle of MMF compensation.

The idea here developed follows to some extent from the
 method using a Chattock coil sensor to cancel the MMF on a
 known length, as described in [16]. Here we take the yoke
 itself as a zero MMF indicator. A few-turn secondary coil
 wound around the upper yoke provides the derivative of the
 magnetic flux ϕ_1 flowing in it. According to the simplified
 reluctance description of the system shown in Fig. 4, where

136

137 the reluctance of the sample is R_s , the reluctance of the upper
 138 and lower yokes is R_y , and that of the wedge-shaped pole
 139 R_p , the MMF drop E pertaining to the magnetic circuit outside
 140 the sample is proportional to the flux ϕ_1 . Since there is
 141 MMF source in the upper yoke, E will be reduced to zero by
 142 canceling the flux ϕ_1 , that is, bringing to zero the voltage
 143 correspondingly induced in the secondary coil. This can be
 144 accomplished by adding a compensation winding on the lower
 145 yoke and controlling it in such a way that the correspondingly
 146 generated MMF $N_c I_c$ leads to the condition $E = 0$. The control
 147 loop is schematically shown in Fig. 5. An analog control card
 148 (PID controller) keeps the voltage $v_1 \propto d\phi_1/dt$ equal to zero,
 149 properly supplying, via a high-gain linear amplifier, the
 150 compensation winding on the lower yoke. Consequently,
 151 the flux ϕ_s in the sample is made to entirely flow in the lower
 152 yoke.

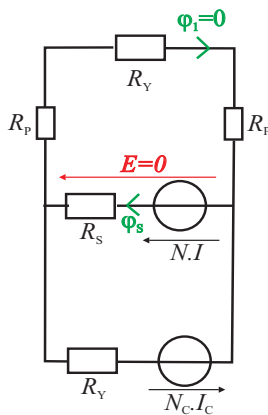

Fig. 4. Reluctance network of the compensated permeameter.

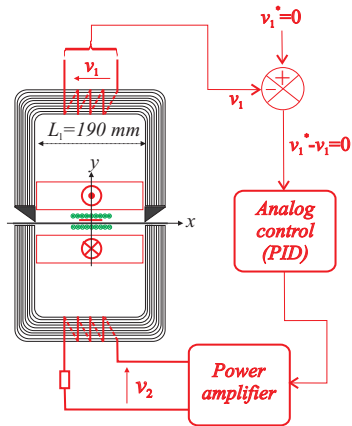

Fig. 5. Compensated permeameter and control circuit.

153 This compensation method is simple and sensitive, since
 154 does not require any specific MMF sensor and a high signal
 155 to-noise ratio is ensured by the high permeability of the
 156 laminations employed in the yokes. The voltage v_1 is, for
 157 example, always much larger than the one achievable by a
 158 Chattock coil, and its control around the zero value is
 159 correspondingly easier and more precise. To be remarked that
 160 imperfect contact between the wedge shaped poles and the
 161 sample, which can be lumped in the pole reluctance R_p , has
 162 little detrimental effect on the permeameter performance,
 163 because the flux in the upper yoke is made to vanish.

III. EXPERIMENTAL RESULTS

The novel compensated permeameter has been tested on nonoriented Fe-(3 wt%)Si sheets (thickness 0.35 mm) and high-permeability (HiB) grain-oriented sheets (thickness 0.28 mm). Energy loss, apparent power, and hysteresis loops were measured under sinusoidal induction waveform at $f = 100$ Hz and peak polarization values $0.2 \text{ T} \leq J_p \leq 1.5 \text{ T}$. The value of the magnetic field H was obtained both by measuring the magnetizing current and by integrating the signal induced in the H -coil placed at the center of the Epstein strip.

A. Non-oriented Fe-Si sheets

Fig. 6 shows the measured energy loss vs. peak polarization obtained through the H -coil and current methods.

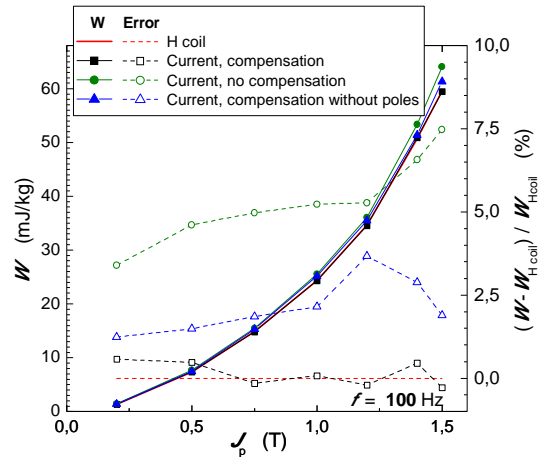

Fig. 6. NO Fe-Si sheets. Comparison of the energy loss measured by the H -coil method and the current measurement method. The permeameter can be compensated as described above, non-compensated (the compensation circuit is not switched on), or compensated without the iron poles. The dashed lines provide the deviations of the loss figures measured with the current method with respect to the H -coil method.

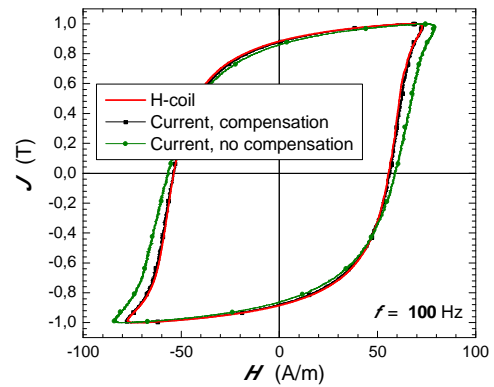

Fig. 7. NO Fe-Si sheets. $J_p = 1 \text{ T}$. Comparison of the hysteresis loops measured by the H -coil method and by the current measurement method, with and without compensation.

It appears that the results by the H -coil method and the current method with compensation and wedge-shaped iron poles on the upper yoke show remarkable agreement. On the other hand, because of the additional loss contribution by the yokes, overestimated figures are obtained by use of the uncompensated permeameter, the higher J_p the higher the loss deviation (up to about 7 %). If the compensation procedure is applied to the standard permeameter configuration without wedge-shaped poles, the loss value is still overestimated (from 2% to 4%), because the magnetic path cannot be fully

198 constrained to the sample length L_i and is slightly longer. 231
 199 The good agreement between the H -coil and the compensated 232
 200 current methods is confirmed by the corresponding 233
 201 measured hysteresis loops shown in Fig. 7. 234

202 **B. HiB grain-oriented sheets** 235

203 Measurements of high permeability GO materials are 236
 204 demanding, because the MMF drop in the yokes may be 237
 205 from negligible with respect to the one in the sample. At the 238
 206 same time, the localized measurements using the H -coil are 239
 207 difficult, especially at low frequencies, because the signal can 240
 208 be very small. This adds to the interest for the here proposed 241
 209 solution, which includes also the measurement of the apparent 242
 210 power. Fig. 8 compares the energy loss values obtained with 243
 211 the H -coil method and the magnetizing current method, with 244
 212 and without compensation, in the GO sheet. It is apparent that 245
 213 the compensated permeameter and the H -coil measurements 246
 214 provide close results. Under uncompensated conditions, one 247
 215 finds instead that the current method overestimates the 248
 216 magnetic loss by a substantial extent, especially at low 249
 217 inductions (about 10% for $J_p = 0.5$ T, 6% for $J_p = 1.5$ T). This 250
 218 is expected, because the loss in the yoke depends only on 251
 219 not on the type of material under test, and its ratio to the 252
 220 sample loss increases with better materials

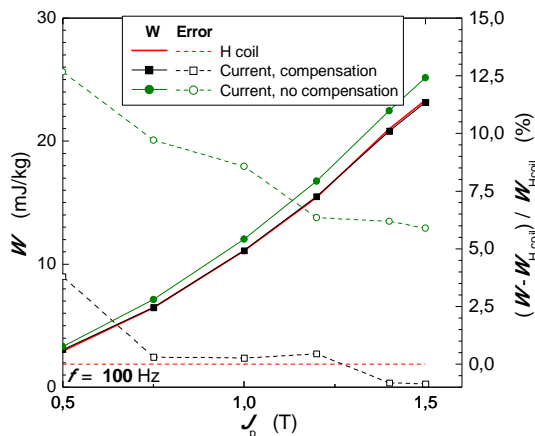

221 Fig. 8. High-permeability GO sheets. Comparison of the energy 252
 222 measured by the H -coil method and the current measurement method, 253
 223 and without compensation. 254

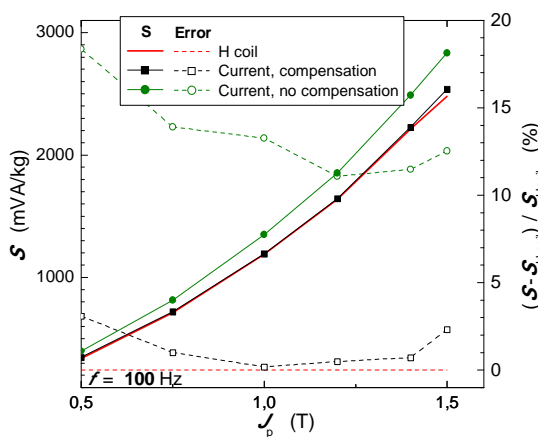

225 Fig. 9. High-permeability GO sheets. As in Fig. 8 for the apparent power. 254

227 Fig. 9 shows the behavior of the measured apparent power. 255
 228 Again, we find good agreement between the results provided 256
 229 by the two methods: H -coil and compensated permeameter. 257
 230 It is noted that part of the small discrepancies occurring between 258

the H -coil and compensated current measurements could be 259
 attributed to the difficulties intrinsic to the H -coil method 260
 (small signal, integration problems...). This further stresses 261
 the merits of the here proposed approach. 262

263 **IV. CONCLUSIONS**

264 A permeameter has been developed, which applies a 265
 266 simple and effective magnetomotive force compensation 267
 268 method for the accurate characterization of soft magnetic steel 269
 269 sheets. It does not require specific sensors, except wedge 270
 271 shaped pole faces for the precise definition of the magnetic 272
 272 path length. It works on the principle of using the flux-closing 273
 273 yoke itself for both sensing and compensation. 274

275 The performances of this permeameter have been validated 276
 276 by measurements on non-oriented and grain-oriented Fe-Si 277
 277 sheets, whose results excellently compare with the results 278
 278 provided by measurements performed using the tangential H - 279
 279 coil method. 280

281 **V. REFERENCES**

282 [1] W. H. Kim et al., "NE-Map-Based Design of an IPMSM for Traction in 283
 283 an EV," *IEEE Transactions on Magnetics*, vol. 50, no. 1, pp. 1-4, 2014.
 284 [2] W. Hua, G. Zhang, and M. Cheng, "Analysis of Two Novel Five-Phase 285
 285 Hybrid-Excitation Flux-Switching Machines for Electric Vehicles," 286
 286 *IEEE Transactions on Magnetics*, vol. 50, no. 11, pp. 1-5, 2014.
 287 [3] J. H. Lee and B. I. Kwon, "Optimal rotor shape design of a concentrated 288
 288 flux IPM-type motor for improving efficiency and operation range," 289
 289 *IEEE Transactions on Magnetics*, vol. 49, no. 5, pp. 2205-2208, 2013.
 290 [4] J. Pippuri, A. Manninen, J. Keranen, and K. Tammi, "Torque density of 291
 291 radial, axial and transverse flux permanent magnet machine 292
 292 topologies," *IEEE Transactions on Magnetics*, vol. 49, no. 5, pp. 2339- 293
 293 2342, 2013.
 294 [5] M. J. Kim et al., "Torque density elevation in concentrated winding 294
 294 interior PM synchronous motor with minimized magnet volume," *IEEE 295
 295 Transactions on Magnetics*, vol. 49, no. 7, pp. 3334-3337, 2013.
 296 [6] L.K. Rodrigues and G.W. Jewell, "Model Specific Characterization of 296
 296 Soft Magnetic Materials for Core Loss Prediction in Electrical 297
 297 Machines," *IEEE Transactions on Magnetics*, vol. 50, no. 11, 2014.
 298 [7] E. Barbisio, F. Fiorillo, and C. Ragusa, "Predicting Loss in Magnetic 298
 298 Steels Under Arbitrary Induction Waveform and With Minor Hysteresis 299
 299 Loops," *IEEE Transactions on Magnetics*, vol. 40, no. 4, pp. 1810- 300
 300 1819, 2004.
 301 [8] IEC Standard Publication 60404-2, Part 2: Methods of measurement of the 301
 301 magnetic properties of electrical steel strip and sheet by means of an 302
 302 Epstein frame, 1996, Geneva, IEC Central Office.
 303 [9] J. Sievert, H. Ahlers, F. Fiorillo, L. Rocchino, M. Hall, and L. 303
 303 Henderson, "Magnetic measurements on electrical steels using Epstein 304
 304 and SST methods", *PTB-Bericht*, vol. E-74, pp. 1-28 (2001).
 305 [10] J. Sievert, "Determination of ac magnetic power loss of electrical steel 305
 305 sheet: present status and trends," *IEEE Transactions on Magnetics*, vol. 306
 306 20, no. 5, pp. 1702-1705, 1984.
 307 [11] F. Fiorillo, *Measurement and characterization of magnetic materials.*: 307
 307 North-Holland, 2004, p.286.
 308 [12] R.S. Girgis, K. Gramm, J. Sievert, and M.G. Wickramasekara, "The 308
 308 single sheet tester. Its acceptance, reproducibility, and application 309
 309 issues on grain-oriented steel," *Le Journal de Physique IV*, vol. 8, no. 309
 309 PR2, pp. 729-732, 1998.
 310 [13] IEC Standard Publication 60404-3, Part 3: Methods of measurement of the 310
 310 magnetic properties of electrical steel strip and sheet by means of a 311
 311 single sheet tester, 1992, Geneva, IEC Central Office.
 312 [14] C. Appino et al., "International comparison on SST and Epstein 312
 312 measurements in grain-oriented Fe-Si sheet steel," *International 313
 313 Journal of Applied Electromagnetics and Mechanics*, vol. 48, no. 2,3, 314
 314 pp. 123-133, 2015.
 315 [15] J. Sievert et al., "New Data on the Epstein to Single Sheet Tester 315
 315 Relationship," *Przeglad Elektrotechniczny*, vol. 7, no. 13, pp. 1-3, 316
 316 2013.
 317 [16] A. Nafalski, A.J. Moses, T. Meydan, and M.M. Abousetta, "Loss 317
 317 measurements on amorphous materials using a field-compensated 318
 318 single-strip tester," *IEEE Transactions on Magnetics*, vol. 25, no. 5, pp. 319
 319 4287-4291, 1989.