



HAL
open science

State of the Art of Gate-Drive Power Supplies for Medium and High Voltage Applications

Loyal Ghossein, Florent Morel, Hervé Morel, Piotr Dworakowski

► **To cite this version:**

Loyal Ghossein, Florent Morel, Hervé Morel, Piotr Dworakowski. State of the Art of Gate-Drive Power Supplies for Medium and High Voltage Applications. PCIM Europe 2016, May 2016, Nuremberg, Germany. pp.CD. hal-01316570

HAL Id: hal-01316570

<https://hal.science/hal-01316570>

Submitted on 13 Jul 2019

HAL is a multi-disciplinary open access archive for the deposit and dissemination of scientific research documents, whether they are published or not. The documents may come from teaching and research institutions in France or abroad, or from public or private research centers.

L'archive ouverte pluridisciplinaire **HAL**, est destinée au dépôt et à la diffusion de documents scientifiques de niveau recherche, publiés ou non, émanant des établissements d'enseignement et de recherche français ou étrangers, des laboratoires publics ou privés.

State of the Art of Gate-Drive Power Supplies for Medium and High Voltage Applications

Layal, GHOSSEIN, SuperGrid Institute – Univ Lyon, INSA Lyon, Ampère, France,

Layal.Ghossein@supergrid-institute.com

Florent, MOREL, Univ Lyon, École Centrale de Lyon, Ampère, France,

Florent.Morel@ec-lyon.fr

Hervé, MOREL, Univ Lyon, INSA Lyon, Ampère, France,

Herve.Morel@insa-lyon.fr

Piotr, DWORAKOWSKI, SuperGrid Institute, France,

Piotr.Dworakowski@supergrid-institute.com

Abstract

Gate-drive power supplies in medium voltage and high voltage direct current (MVDC / HVDC) applications require medium to high voltage insulation. In MVDC and HVDC power converters there are a number of different power supply techniques that can be used for powering the gate-drives of floating power switches, which are commonly found in such converters. This paper presents the state of the art of gate-drive power supply techniques. Contactless energy transfer methods and self-powering techniques used for powering the gate-drives of power switches are presented. The power range obtained and isolation range for the different solutions are then presented. Finally, the most promising techniques for MV and HV applications are highlighted.

1. Introduction

The main component of any power converter is a power module, containing power semiconductor devices. The power module is driven by a gate-drive board for which the main role is the conditioning of the control signal, but usually it also realises some protection functions. In general, the gate-drive requires a low power supply providing somewhere in the range of 2-100 of watts at a voltage of 15-25 volts. For low voltage applications (up to a few kilovolts), the gate-drive supply can be realised using isolation transformers. For example, a solution was presented in [1] to supply up to 6 gate-drives with an isolation voltage of 15 kV. However, for medium voltage (tens of kilovolts) and high voltage (hundreds of kilovolts) applications, more advanced techniques are required. This article considers a study case of a high voltage DC-DC converter based on front-to-front connected Alternated Arm Converters (AAC) (Fig. 1), which is an evolution of the Modular Multilevel Converter (MMC) [2]; hereafter, this topology will be named AAC-MMC. In such a converter, the control signals can be transmitted to the gate-drive using fibre optics, but the gate-drive supply technique needs to be more deeply studied. This paper deals with the power supply of classic gate-drive boards. It is for this reason that the gate-drive specific circuits like the one reported in [3] or light triggered thyristors are not considered.

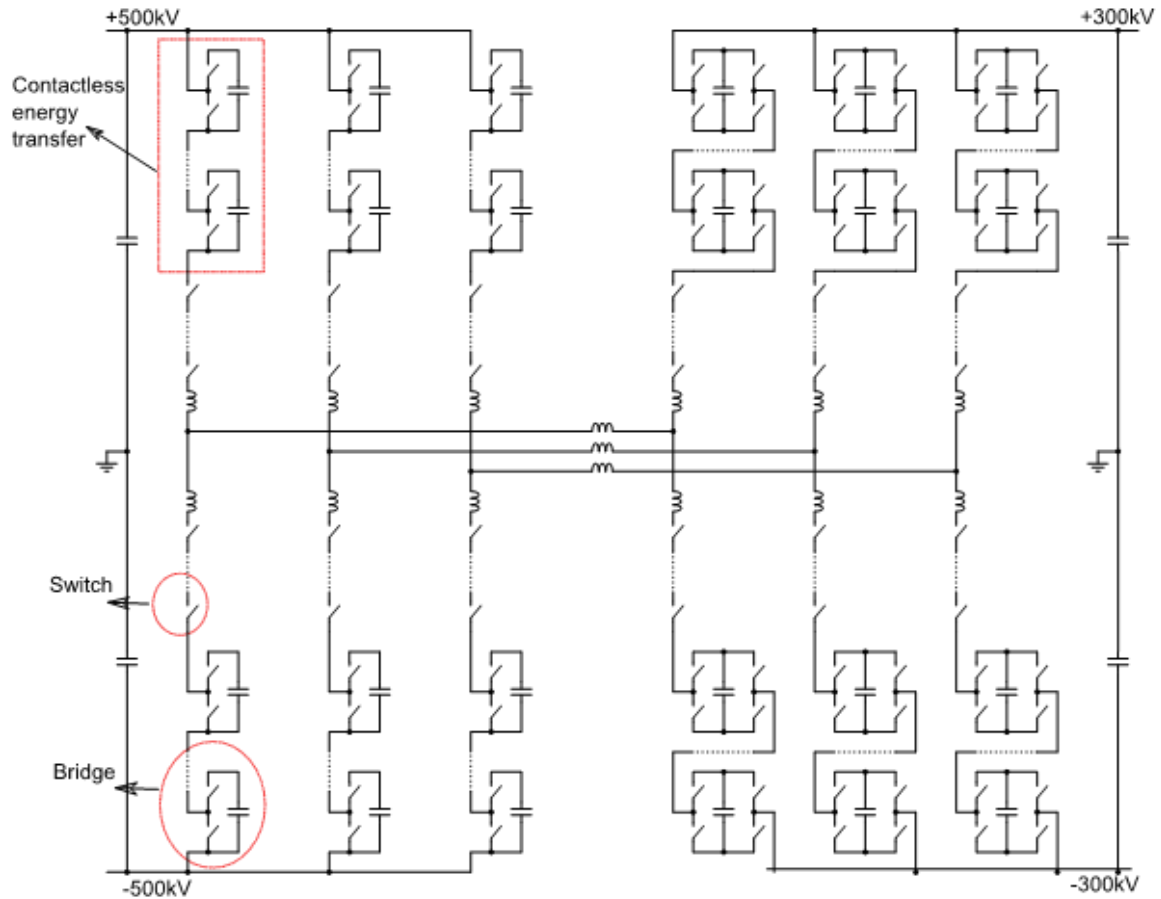

Fig. 1. Location of need of gate-drive power supply in an Alternated Arm Converter (AAC) topology [2]

In this article, different possible techniques for gate-drive supply are classified (Fig. 2), after which some of them are analysed in detail. The first class of gate-drive supply (contactless energy transfer, paragraph 2) considers that the energy source is outside of the converter and referenced to ground; as a consequence, medium/high voltage insulation is required. The second class (energy harvesting, paragraph 3) uses the energy of the power converter circuit. In this case the insulation to ground is not applicable, as the gate-drive supply is referenced to the same floating potential as the power module. The last paragraph gives the conclusion about what appears to be the most promising gate-drive supply state of the art techniques for medium and high voltage applications.

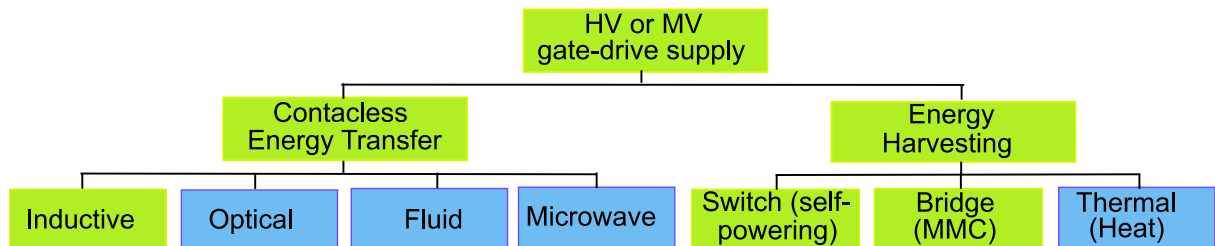

Fig. 2. Classification of MV and HV gate-drive supply possible techniques, with those that are detailed in this article highlighted in green

2. Contactless energy transfer

Many research efforts have been carried out on developing wireless power transfer (WPT) using various physical phenomena. To the best knowledge of the authors, none of these phenomena (e.g. optical, fluid and microwave), excluding induction, have been investigated for powering gate-drives.

Power can be transferred over optic fibers but the efficiency and the maximum transferred power are too low. A compressed-air-powered electric generator can be found in [4] but the life time is too low for industrial applications. For microwaves, efficiency and maximum power are low and the converter environment with many metallic parts is not favorable.

Inductive power transfer (IPT) is a WPT technology that uses coils with large air gaps (up to several cm). So, it provides a voltage insulation in the range of tens of kV. As it can be used to transfer several tens of watts with a good efficiency, it has been found to be a promising solution for gate-drive power supply in MV applications.

2.1. Supply single gate drive

An ICPT (Inductive Coupled Power Transfer) circuit was shown in [5] based on a DC-DC converter circuit using a coreless transformer with insulation up to 35 kV. The adopted circuit (Fig. 3) achieved 100 W at the output with more than 80% efficiency.

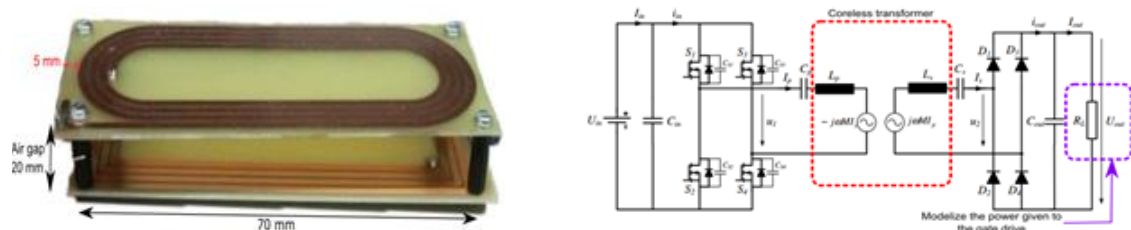

Fig. 3. Coreless transformer and the DC-DC converter used to replace the ICPT [5]

A recent study [6], using a schematic close to what has been shown in Fig. 3, also used an IPT solution to supply the auxiliary power of an MV converter. The transformer employed was made out of two concentric cylinders. The system achieved a 30 W output power with 90% efficiency.

2.2. Supply of multiple gate-drives

While the studies listed in the previous section used one power supply for each gate-drive, other studies showed the possibility of using a single power supply for several gate-drives providing an interesting solution for multilevel converters where many gate-drives at various floating potentials are needed and for converters where there are several switches connected in series.

Also, a galvanic isolation solution using printed circuit boards has been presented in [7]. The latterly mentioned circuit used one transmitting board and six receiving boards. The galvanic isolation was assured using the required air gap between the boards (Fig. 4 left). This solution was used for an MV inverter, which had an input and output voltage of 6.6 kV. The total power received by the receiving boards was around 16 W.

The solutions that have been described in [8, 9] and [10] uses a “loop wire” (Fig. 4 right) where a resonant power supply creates a medium frequency current (tens of kHz) in the loop wire. The energy was distributed and rectified on each gate-drive that was magnetically coupled with the loop wire. It was considered to transfer the control signal and the energy on the same loop wire [8, 9]. Another recent article [11] proposed to use this method to supply the gate-drives in an MMC operating at MV (up to 9 kV input voltage and 35 kV output voltage, at a rated power of 250 kVA). The loop wire passed through a number of ring-core-based transformers to provide an insulation to ground level in the range of 20 kV.

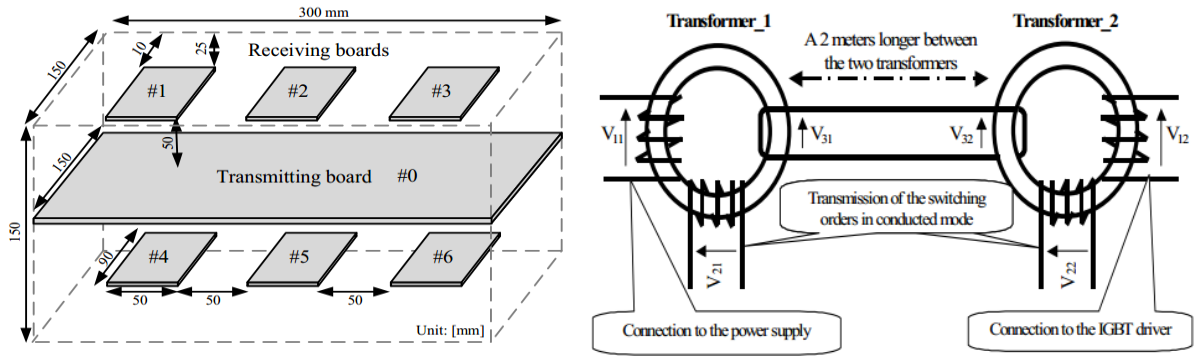

Fig. 4. Schematic view of the galvanic isolation solution using printed circuit boards for gate-drive power supply (left) [7], DGIT (Double Galvanic Insulated Transformer) with three windings (right) [9]

3. Energy harvesting

An alternative solution to contactless energy transfer is the energy harvesting from the power circuit.

An energy harvesting solution has been studied in [12] showing the possibility of using a thermoelectric module (TEM) attached to the power switch. In this study, for the best case, a small amount of power (0.5W) was harvested and the author claims that it could be used to supply the gate-drive. Also the TEM allows the reduction of the switch temperature for 4°C to 7°C. But the main drawback is the necessity to wait for the switch to be sufficiently heated in order for the TEM to work. Also the power that can be harvested depends on the switch temperature, then on the average current in the switch.

Depending on the converter topology a local energy storage, as the capacitor in the AAC-MMC submodule (bridge in Fig. 1), may be available. Alternatively the voltage across the power switch (switch in Fig. 1) can be used to supply its own gate-drive (self-powering). For self-powering, a circuit is connected in parallel to the power switch to harvest the energy used to supply the gate-drive of this switch. Consequently, no external power source is required. Generally the energy is gathered during the switch turn-off transition, but it can also be made during turn-on transition [13], on state or even during off state [14]. The solutions applicable for self-powering may be considered for bridge capacitor but not inversely. The major difference is the impact of the circuit on the power switch behavior.

3.1. Integrable self-powering topology

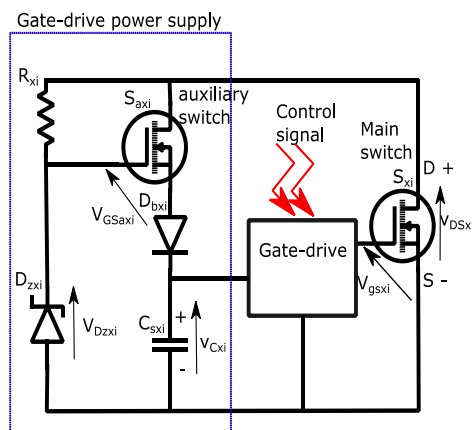

Fig. 5. Self-powering gate-drive (SPGD) circuit [27]

The most studied topology for low voltage applications is the MOSFET/MOSFET topology [15] (Fig. 5).

During the turn-off of the main switch a current charging C_{sxi} flows through the auxiliary MOSFET, then some energy is stored in capacitor C_{sxi}.

The voltage between gate-source of S_{axi} is given by $V_{GSaxi} = V_{Dzxi} - V_{Csxi}$. When this voltage becomes lower than the threshold voltage, S_{axi} is switched off. The Zener diode D_{zxi} is polarized by the resistor R_{xi}. As a result, the voltage across the capacitor is regulated by the forward voltage of D_{zxi}. The diode D_{bxi} prevents the discharging of C_{sxi}, via the internal diode of the auxiliary MOSFET, when the main power switch S_{xi} is on.

The same topology was adapted to drive an IGBT in [16]. Similar topologies were based on JFET/MOSFET [15] for auxiliary/main switch and others used JFET/JFET topology [17].

These solutions have the following main advantages:

- All the components could be integrated according to the technological process of the main switch. Some studies showed solutions of integrating the self-powering components in the same package [18, 19, 20] where the insulation is given by the semiconductor package.
- It contains a small amount of components.

The important drawback of these solutions is the very low efficiency. For instance, with a DC power source $V_{DS}=400$ V and a regulated voltage level $V_{Csxi}=20$ V, the gate-drive supply efficiency reaches 5 % [18]. However, [21] claims that with replacing in Fig. 5 the auxiliary MOSFET and the polarization branch by a Darlington structure, the efficiency was much higher, making the system suitable for MV and HV applications. In [22], a performance analysis of this circuit and an optimized circuit was done in order to study the feasibility of this circuit for higher voltage applications. If moderated turn-off transient and current levels are acceptable, then the performance of the design is satisfying. In this test a 600V CoolMOS is selected as the main MOSFET. The study showed that the efficiency of the system would be improved if the design was integrated in the package of the main MOSFET since the equivalent leakage inductance of the circuit could be minimized.

3.2. Self-powered resonant gate-drive

The topology presented in [23] is for a resonant SPGD that operates for a wide range of frequency (from hundreds of Hz to hundreds of kHz). The gate-drive gets energy from the main switch. The power stage is formed of the complementary P-channel and N-channel power MOSFETs, resonant gate inductor, and self-powered unit (SPU) (Fig. 6 right). This SPU is formed of a HV capacitor C_1 , a LV storage capacitor C_2 , a clamp capacitor C_3 which is used to clamp the gate voltage, auxiliary resistors R_1 and R_2 that are used to make a path for the current to charge C_2 and an inductor L .

The main drawback of this topology is that the line capacitor C_1 (Fig. 6 left) has to be at the same voltage rating as the main switch.

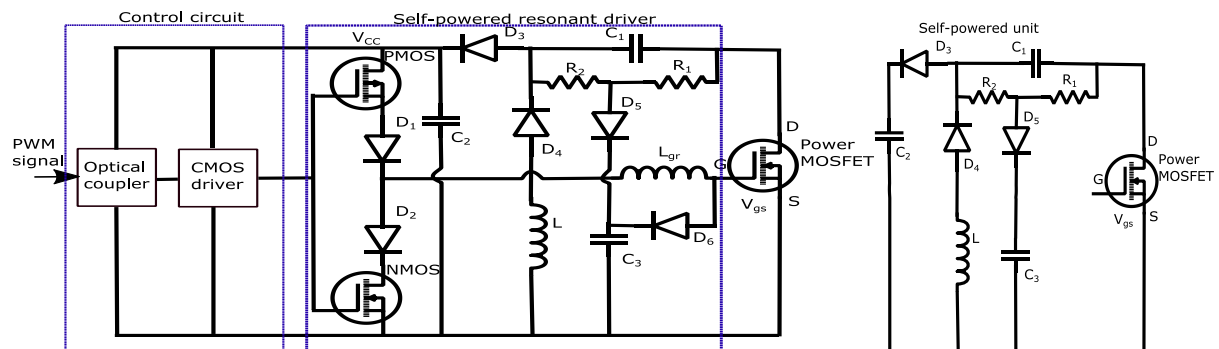

Fig. 6. High frequency resonant SPGD topology (Complete circuit, left) and its self-powered unit (Part of the circuit, right) [23]

3.3. Snubber capacitor self-powered gate-drive

In [13], another self-powered topology was proposed for thyristors. The proposed circuit drives power from energy stored in the snubber capacitor at turn-on and from the voltage across the thyristor at turn-off to supply its gate-drive.

Also in [14], a self-powered circuit for a GCT gate-drive was presented. The supply uses the energy at the snubber circuit of the GCT switch and then provides the gate-drive a regulated DC voltage.

3.4. Bridge capacitor supplied gate-drive

An AAC-MMC submodule is formed of one (Fig. 7 left) or two half-bridges. Each submodule includes a capacitor providing a voltage source that can be used to supply the gate-drive. Typically, the voltage at the DC capacitor can reach few kV which could be challenging for the designing of a suitable step-down voltage ratio converter. Indeed, the dedicated DC-DC converter should be able to withstand some kV at the input and provide some V at the output to supply the gate-drive. The use of the input DC capacitor as a floating power supply is not a recent idea, and amelioration of respective auxiliary power supply (APS) topologies or new topologies are continuously proposed. This method is used to solve the problem of supplying the gate-drive in a bridge (Fig. 1).

An APS for submodules was shown in [24]. The topology used is a tapped-inductor buck converter (TI-buck converter) (Fig. 7 right). It is a non-isolated step-down DC-DC converter with an input voltage of 3 kV and a 100 W power rating. S_1 is a power switch and it is formed of series of switches in order to withstand the high voltage.

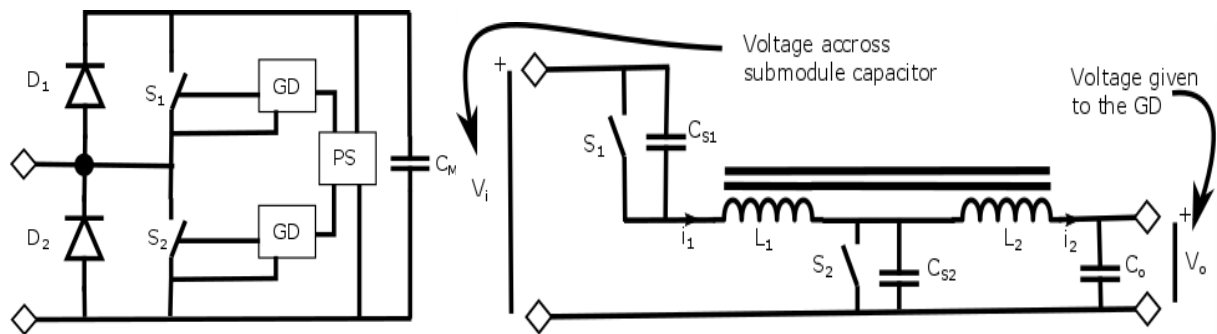

Fig. 7. Half-bridge submodule showing auxiliary power supply (PS) and gate-drive (GD) (left). Tapped inductor buck converter topology (right). [24]

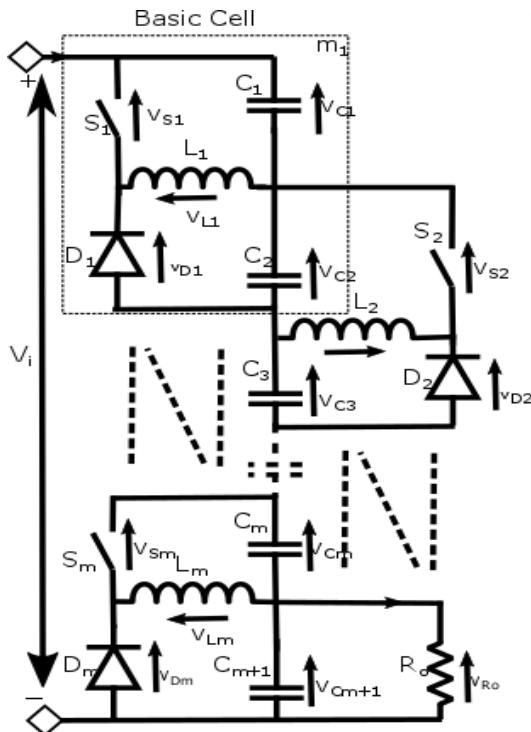

Fig. 8. APS topology for AAC-MMC submodule gate-drive formed of m number of cells. [25]

In [25], a non-isolated and non-regulated multi-cell converter was proposed (Fig. 8). In this converter, the switches are ON at the same time, in the first phase, and then are switched off, in the second phase. When the switches are on, the voltage source provides energy to the load R_o (modelling the gate-drive) and the inductances are charged and the capacitors that were previously charged are discharging. When the switches are off, the diodes are on, and the energy stored in the inductors is transferred to the load. Then, the voltage source charges the capacitors. This topology can be used in applications where ultrahigh step-down converter is needed. It is then well adapted to the application considered in this section. The complete converter has a high step-down voltage ratio multi-cell stage followed by a regulated and isolated stage to supply an AAC-MMC submodule gate-drive. Such a converter was realized with seven cells and with a nominal input voltage range of 2.8 kV, almost 200 W was harvested at the output with a nominal voltage of 350 V. The second stage must include a DC-DC converter in order to have the low voltage needed at the gate-drive (order of 20V).

4. Conclusion

This paper presents the state of the art of gate-drive power supply techniques for MV and HV applications. The methods shown in this paper are able to provide the power required to supply the gate-drive (some tens of W). For MV applications, IPT is a promising technology but the insulation voltage in the range of hundreds of kV would lead to air gaps so large that the efficiency would be seriously decreased or the coil size would be dramatically increased. Other contactless energy transfer techniques based on microwaves or laser transmission would allow the system to operate at higher voltages but the power density of such a supply is quite low [26] and, to the best knowledge of the authors, until now no paper has been published on a gate-drive powered in such a way.

The application case of the AAC-MMC submodule is quite specific since the capacitor in each submodule provide a voltage source with the same potential reference as the power switches. Self-powering methods have the possibility to harvest energy during the turn-off transition (in general) of the power switch or from snubbers to supply the gate-drive. But as silicon carbide (SiC) components are expected to be used in HV converters and as these components will have reduced commutation durations, the energy recovered during turn-off and the energy stored in snubbers could be too low. So, innovative self-supply topologies are a potential candidate for future high voltage applications involving power switches in series.

References

- [1] J. Afsharian, N. Zaragari and B. Wu, "A special high-frequency soft-switched high-voltage isolated DC/DC power supply for multiple GCT gate drivers," in *Energy Conversion Congress and Exposition (ECCE), 2010 IEEE*, 2010.
- [2] T. Lu th, M. Merlin, T. Green, C. Barker, F. Hassan, R. Critchley, R. Crookes and K. Dyke, "Performance of a DC/AC/DC VSC system to interconnect HVDC systems," in *AC and DC Power Transmission (ACDC 2012), 10th IET International Conference on*, 2012.
- [3] H. Fujita, "A Resonant Gate-Drive Circuit With Optically Isolated Control Signal and Power Supply for Fast-Switching and High-Voltage Power Semiconductor Devices," *IEEE Transactions on Power Electronics*, vol. 28, no. 11, pp. 5423-5430, 2013.
- [4] Metal work pneumatic, "Pneumo-power," [Online]. Available: <http://www.metalwork.it/eng/pneumo-wireless/index.html>.
- [5] R. Steiner, P. Steimer, F. Krismer and J. Kolar, "Contactless energy transmission for an isolated 100W gate driver supply of a medium voltage converter," in *Industrial Electronics, 2009. IECON '09. 35th Annual Conference of IEEE*, 2009.
- [6] B. Wunsch, J. Bradshaw, I. Stevanovic, F. Canales, W. Van-der-Merwe and D. Cottet, "Inductive power transfer for auxiliary power of medium voltage converters," in *Applied Power Electronics Conference and Exposition (APEC), 2015 IEEE*, 2015.
- [7] K. Kusaka, M. Kato, K. Orikawa, J.-I. Itoh, I. Hasegawa, K. Morita and T. Kondo, "Galvanic isolation system for multiple gate drivers with inductive power transfer --- Drive of three-phase inverter," in *Energy Conversion Congress and Exposition (ECCE), 2015 IEEE*, 2015.
- [8] S. Brehaut and F. Costa, "Gate driving of high power IGBT by wireless transmission," in *Power Electronics and Motion Control Conference, 2006. IPEMC 2006. CES/IEEE 5th International*, 2006.
- [9] S. Brehaut and F. Costa, "Gate driving of high power IGBT through a Double Galvanic Insulation Transformer," in *IEEE Industrial Electronics, IECON 2006 - 32nd Annual Conference on*, 2006.
- [10] H. Wen, W. Xiao and Z. Lu, "Current-Fed High-Frequency AC Distributed Power System

- for Medium--High-Voltage Gate Driving Applications," *IEEE Transactions on Industrial Electronics*, vol. 60, no. 9, pp. 3736-3751, 2013.
- [11] D. Pefitsis, M. Antivachis and J. Biela, "Auxiliary power supply for medium-voltage modular multilevel converters," in *Power Electronics and Applications (EPE'15 ECCE-Europe), 2015 17th European Conference on*, 2015.
- [12] Y. Tian, D. Vasic and S. Lefebvre, "Application of thermoelectricity to IGBT for temperature regulation and energy harvesting," in *Industrial Electronics (ISIE), 2012 IEEE International Symposium on*, 2012.
- [13] D. M. Raonic, "SCR self-supplied gate driver for medium-voltage application with capacitor as storage element," *Industry Applications, IEEE Transactions on*, vol. 36, no. 1, pp. 212-216, 2000.
- [14] W. Hu, B. Wu, N. Zargari and Z. Cheng, "A Novel Self-Powered Supply for GCT Gate Drivers," *IEEE Transactions on Power Electronics*, vol. 24, no. 4, pp. 1093-1099, 2009.
- [15] R. Mitova, "Intégration de l'alimentation de la commande rapprochée d'un interrupteur de puissance à potentiel flottant," *Institut National Polytechnique de Grenoble-INPG*, 2005.
- [16] T. V. Nguyen, P. Jeannin, E. Vagnon, D. Frey and J.-C. Crebier, "Series Connection of IGBTs With Self-Powering Technique and 3-D Topology," *IEEE Transactions on Industry Applications*, vol. 47, no. 4, pp. 1844-1852, 2011.
- [17] D. Pefitsis, "On gate drivers and applications of normally-on SiC JFETs," 2013.
- [18] J.-C. Crébier and N. Rouger, "Loss free gate driver unipolar power supply for high side power transistors," *Power Electronics, IEEE Transactions on*, vol. 23, no. 3, pp. 1565-1573, 2008.
- [19] N. Rouger, J.-C. Crebier, R. Mitova, L. Aubard and C. Schaeffer, "Fully integrated driver power supply for insulated gate transistors," in *Power Semiconductor Devices and IC's, 2006. ISPSD 2006. IEEE International Symposium on*, 2006.
- [20] N. Rouger and J.-C. Crebier, "Toward Generic Fully Integrated Gate Driver Power Supplies," *IEEE Transactions on Power Electronics*, vol. 23, no. 4, pp. 2106-2114, 2008.
- [21] N. Rouger, J.-C. Crebier, H. T. Manh and C. Schaeffer, "Toward integrated gate driver supplies: Practical and analytical studies of high-voltage capabilities," in *Power Electronics Specialists Conference, 2008. PESC 2008. IEEE*, 2008.
- [22] S. Busquets-Monge, D. Boroyevich, R. Burgos and Z. Chen, "Performance analysis and design optimization of a self-powered gate-driver supply circuit," in *Industrial Electronics (ISIE), 2010 IEEE International Symposium on*, 2010.
- [23] H. Wang and F. Wang, "A self-powered resonant gate driver for high power MOSFET modules," in *Applied Power Electronics Conference and Exposition, 2006. APEC '06. Twenty-First Annual IEEE*, 2006.
- [24] T. Modeer, S. Norrga and H.-P. Nee, "High-voltage tapped-inductor buck converter auxiliary power supply for cascaded converter submodules," in *Energy Conversion Congress and Exposition (ECCE), 2012 IEEE*, 2012.
- [25] G. Tibola, J. Duarte and A. Blinov, "Multi-cell DC-DC converter with high step-down voltage ratio," in *Energy Conversion Congress and Exposition (ECCE), 2015 IEEE*, 2015.
- [26] S. Sohr, R. Rieske, K. Nieweglowski and K. J. Wolter, "Laser Power Converters for optical power supply," in *Electronics Technology (ISSE), 2011 34th International Spring Seminar on*, 2011.
- [27] S. Busquets-Monge, J. Rocabert, J.-C. Crebier and J. Peracaula, "Diode-clamped multilevel converters with integrable gate-driver power-supply circuits," in *Power Electronics and Applications, 2009. EPE '09. 13th European Conference on*, 2009.