



**HAL**  
open science

## Some aspects of functional equations

Jean Dhombres

► **To cite this version:**

| Jean Dhombres. Some aspects of functional equations. Chulalongkorn University, 1979. hal-01309312

**HAL Id: hal-01309312**

**<https://hal.science/hal-01309312>**

Submitted on 29 Apr 2016

**HAL** is a multi-disciplinary open access archive for the deposit and dissemination of scientific research documents, whether they are published or not. The documents may come from teaching and research institutions in France or abroad, or from public or private research centers.

L'archive ouverte pluridisciplinaire **HAL**, est destinée au dépôt et à la diffusion de documents scientifiques de niveau recherche, publiés ou non, émanant des établissements d'enseignement et de recherche français ou étrangers, des laboratoires publics ou privés.

**SOME ASPECTS OF FUNCTIONAL EQUATIONS**

**Jean DHOMBRES**

**SOME ASPECTS OF  
FUNCTIONAL EQUATIONS**

**Jean DHOMBRES**

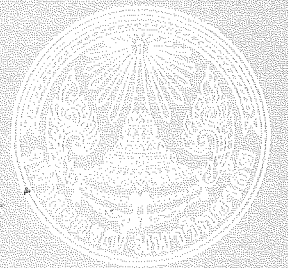

**DEPARTMENT OF MATHEMATICS**

**CHULALONGKORN UNIVERSITY**

**1979**



Lecture Notes

SOME ASPECTS

of

FUNCTIONAL EQUATIONS

Jean DHOMBRES,

*Chulalongkorn University (Thailand)*

*Universite de Nantes (France)*

*Universite d'Ottawa (Canada)*

1979

Department of Mathematics  
Chulalongkorn University

*Bangkok, Thailand*

*This lecture notes is published by the  
Department of Mathematics, Chulalongkorn  
University, Bangkok, Thailand with partial  
support from The Mathematical Associa-  
tion of Thailand and the French Embassy  
in Bangkok.*

Copyright 1979

by Department of Mathematics  
Chulalongkorn University

Printed by  
Chulalongkorn University Press  
Bangkok, Thailand 1979

## คำนำ

เพื่อส่งเสริมการวิจัยในสาขาสถิติศาสตร์ คณะวิทยาศาสตร์ จุฬาลงกรณ์มหาวิทยาลัย ได้จัดสัมมนาในหัวข้อ สหการพหุศาสตร์ตามเงื่อนไข ระหว่างวันที่ 24 กรกฎาคม ถึงวันที่ 4 สิงหาคม พ.ศ. 2521 โดยเชิญ Dr. Jean DHOMBRES เป็นผู้บรรยาย

เรื่องต่างๆ ที่นำมาบรรยายในการสัมมนาครั้งนี้เป็นความรู้เบื้องต้นและเรื่องที่เป็นความรู้ใหม่ซึ่งยังไม่เคยพิมพ์เผยแพร่มาก่อน ทั้งผู้บรรยายและภาควิชาคณิตศาสตร์ จุฬาลงกรณ์มหาวิทยาลัย เห็นร่วมกันว่าควรจะมีการพิมพ์เผยแพร่ความรู้เหล่านี้ให้เป็นประโยชน์แก่นักคณิตศาสตร์โดยทั่วไปด้วย จึงได้จัดพิมพ์หนังสือเล่มนี้ขึ้น

ในการจัดสัมมนาครั้งนี้ ข้าพเจ้าในฐานะผู้ประสานงานใคร่ขอขอบคุณ Dr. DHOMBRES ซึ่งยินดีรับเป็นผู้บรรยาย รวมทั้งเปิดโอกาสให้ผู้เข้าสัมมนาพบปะเพื่ออภิปรายปัญหาต่างๆ นอกเวลาสัมมนาอย่างเต็มที่ ขอขอบคุณสถานทูตฝรั่งเศสในกรุงเทพฯ ที่กรุณาจัดให้ Dr. DHOMBRES ได้มาบรรยาย และท้ายสุดขอขอบคุณ ศาสตราจารย์ สุรวิทย์ กองสาสนะ หัวหน้าภาควิชาคณิตศาสตร์ จุฬาลงกรณ์มหาวิทยาลัย ซึ่งให้ความสำคัญกับการสัมมนาครั้งนี้เป็นอย่างยิ่ง

วิรุฬห์ บุญสมบัติ



## INTRODUCTION

Functional equations arise in most branches of mathematics: from the functional equation of the Riemann function in number theory, to the equation of entropy in probability theory; from the defining equation of a derivation in the theory of Banach algebras, to numerous equations in combinatorics; etc. Although lacking general results in the way of existence and uniqueness, and those of a spectacular nature, the theory of functional equations was not made the object of encyclopedic research until the end of the last decade.

It is by no means the intention of this work to completely cover the field in some systematic way. As a result of the kindness of Professor Virool Boonyasombhat, a seminar on the subject took place at the Department of Mathematics of the Chulalongkorn University of Bangkok (Thailand) out of which these notes were born.

The goal of the seminar was to introduce and utilize several classical tools of analysis: convex functions, Baire's theorem, the Lebesgue measure, etc. One theme may have been chosen to give coherence to the seminar, namely the study of conditional Cauchy equations, an active area of functional equations. On one hand one can quickly attain interesting results in this area by elementary means; on the other hand certain unresolved problems might have the effect of attracting the interest of some of the participating graduate students and imparting to them the attitudes of research in mathematics.

It was intended that the knowledge of mathematics usually acquired after the first two years of university would suffice for the understanding of these notes, that all major results used would be

proved therein and that a reasonably average level of exposition would be maintained. A strain is put on these principles when justifying the study of conditional Cauchy equations and when exhibiting some consequences in functional analysis (in the last chapter for example).

It is a pleasure for me to thank all the participants in the seminar, as well as Chulalongkorn University and the French Ministry of Foreign Affairs for their financial aid which made the seminar and this publication possible.

Jean DHOMBRES  
Université de Nantes (France)  
Université d'Ottawa (Canada) - 1978 -  
Chulalongkorn University (Thailand)

Special thanks are due to Professor J. Aczel who scrutinized the whole manuscript and to Professors J. Todd, R. Ger, P. Kannapan and G. Targonski, who helped me by making various comments.

I also thank Ms Lynda Hohner and Mrs Colette Riddle for their patience in the typing.

## SOME ASPECTS OF FUNCTIONAL EQUATIONS

### TABLE OF CONTENTS

FOREWORD  
INTRODUCTION

#### I Basic functional equation : Cauchy equation on the real axis :

- 1.1 Introduction
- 1.2 A generalization
- 1.3 Some consequences
- 1.4 Other algebraical conditions on Cauchy equation
- 1.5 Some vocabulary
- 1.6 Cauchy inequality : Suradditive functions

#### II Some examples leading to conditional functional equations :

- 2.1 Gauss functional equation
- 2.2 Mikusinski functional equation
- 2.3 A conditional Cauchy equation
- 2.4 Jensen functional equation
- 2.5 Some generalized Cauchy equation
- 2.6 Some equation from information theory

#### III Conditional Cauchy equations :

- 3.1 A classification for conditional Cauchy equations
- 3.2 Conditional Cauchy equations of type I
- 3.3 Conditional Cauchy equations of type I<sub>2</sub>
- 3.4 An application to some extension problems for homomorphisms
- 3.5 Bohr compactification of  $\mathbb{R}$
- 3.6 A conditional Cauchy equation on a "thin" set  $Z$
- 3.7 Additive functions in number theory

#### IV Conditional Cauchy equations of type II :

- 4.1  $Z$  is a square ;  $X = Y$  is a subsemigroup of an abelian group
- 4.2  $Z$  is a triangle in the abelian case
- 4.3 Hamel bases
- 4.4 Converse theorems
- 4.5 Numerical additive functions on  $\mathbb{R}^n$
- 4.6 An application to Jensen convex functions
- 4.7 Other additive functions linked with number theory
- 4.8 Generalized Conditional Cauchy equations of type II
- 4.9 Application : a characterization of inner product spaces



## V Conditional Cauchy equations of type III, IV and V :

- 5.1 Mikusinski functional equation
- 5.2 Generalizations of Mikusinski functional equation
- 5.3 Conditional Cauchy equations of type III<sub>2</sub>
- 5.4 A dual equation of Mikusinski functional equation
- 5.5 Conditional Cauchy equations in the tubular case
- 5.6 Conditional Cauchy equations of type V

## VI Functional equations with superpositions of the unknown function :

- 6.1 On a division model for a population
- 6.2 A functional equation on an abelian group : linear iteration of order two
- 6.3 Application : a characterization of inner product spaces
- 6.4 A functional equation in the theory of geometric objects
- 6.5 The functional equation of multiplicative symmetry on an abelian group
- 6.6 Applications to algebra : associative and commutative mappings

## VII Operator theory and functional equations :

- 7.1 Reynolds operators
- 7.2  $\mathcal{H}(\kappa)$  operators
- 7.3 Derivation operators
- 7.4 Multiplicatively symmetric operators
- 7.5 Extreme operators in  $L^1$

Index of notations and symbols

Subject index

Bibliographical indications

## CHAPTER 1

Basic functional equation: Cauchy equation on the real axis

*Programme* In this Chapter, we introduce the Cauchy equation and solve it under mild regularity assumptions. We maintain an elementary level by avoiding converse results and by choosing the real axis as a domain for Cauchy solutions. We also try to avoid regularity assumptions by adding algebraic conditions (or supplementary functional equations) to the Cauchy equation itself. We end the chapter with a quick glance at Cauchy inequalities on the real axis.

1.1 Introduction There is no doubt that the most basic functional equation is the so-called Cauchy functional equation for a functional  $f: \mathbb{R} \rightarrow \mathbb{R}$

$$(1) \quad f(x+y) = f(x) + f(y)$$

valid for all  $x, y$  in  $\mathbb{R}$ .

Such an equation was solved, under a continuity assumption, by A.L. Cauchy, in 1821, as a direct application of his new foundations for analysis (It can be found in his Cours d'Analyse de l'Ecole Polytechnique, vol. 1, Chapter V). For the sake of completeness, let us prove here a slight generalization of Cauchy's result.

Theorem 1.1 Let  $f: \mathbb{R} \rightarrow \mathbb{R}$ . Let us suppose that on a non-empty open subset of  $\mathbb{R}$ ,  $f$  is bounded above (i.e. there exists a real  $A$  and an open set  $\theta \subset \mathbb{R}$ ,  $\theta \neq \emptyset$ , such that  $f(x) \leq A$  for all  $x$  in  $\theta$ ). Let us suppose that  $f$  satisfies the Cauchy equation (1) for all  $x, y$  in  $\mathbb{R}$ .

Then there exists a constant  $a$  (a real number  $a = f(1)$ ) such that for all  $x$  in  $\mathbb{R}$

$$f(x) = ax$$

The same result holds if  $f$  is bounded below (or if  $|f|$  is bounded above) on a non-empty open subset.

Proof Let us consider  $g(x) = f(x) - xf(1)$ . By replacing, if necessary, the open subset  $\theta$  by a bounded open subset of  $\mathbb{R}$  (still called  $\theta$ ) we get a function  $g$  which is bounded above on  $\theta$ . Moreover,  $g: \mathbb{R} \rightarrow \mathbb{R}$  also satisfies Eq (1) with  $g(1) = 0$ .

Then Eq (1), with  $y = 1$ , as applied to  $g$ , proves that  $g$  is periodic and of period 1. If  $\theta$  contains an interval of length at least 1, we obtain that  $g$  is bounded above on the whole of the real axis  $\mathbb{R}$ . However we made no assumption over the size of the non-empty open set  $\theta$ . To get the same conclusion - global boundedness of  $g$  from above - it is enough to prove that  $g$  possesses as small a period as we wish. To prove this, we notice that for any positive integer  $n$

$$0 = g(1) = g\left(\frac{n}{n}\right) = ng\left(\frac{1}{n}\right)$$

due to Eq (1).

Thus  $g\left(\frac{1}{n}\right) = 0$  for any such integer  $n$ . Going back to Eq (1) we get as required.

$$g\left(x + \frac{1}{n}\right) = g(x) \quad \text{for all } x \text{ in } \mathbb{R}.$$

We may now suppose that there exists a  $B$  in  $\mathbb{R}$  such that for all  $x$  in  $\mathbb{R}$

$$g(x) \leq B.$$

Clearly  $g(0) = 0$  ( $g(x) = g(x+0) = g(x) + g(0)$ ) and  $g(-x) = -g(x)$  ( $0 = g(0) = g(x-x) = g(x) + g(-x)$ ). Thus  $-g(x) \leq B$ . So that for all  $x$  in  $\mathbb{R}$ ;

$$-B \leq g(x) \leq B$$

If  $B \leq 0$ , we immediately deduce  $g \equiv 0$ . But such is also the general case. Due to Eq (1), we have  $g(nx) = ng(x)$  for any positive integer  $n$ . This yields

$$-\frac{B}{n} \leq g(x) \leq \frac{B}{n}$$

As  $n$  is arbitrary, we get  $g(x) = 0$  for all  $x$ , which ends the proof of Theorem 1.1 for an upper bound. When  $f$  is bounded from below, then  $-f$  satisfies all conditions of the first part of Theorem 1.1 and so  $-f(x) = ax$ . Thus  $f(x) = (-a)x$  for all  $x$  in  $\mathbb{R}$ . If  $|f|$  is bounded from above on  $\theta$ , so is  $f$ .

Corollary 1.1 The general solution of Eq (1), where  $f: \mathbb{R} \rightarrow \mathbb{R}$  is continuous at least at one point, is  $f(x) = ax$ .

A function  $f: \mathbb{R} \rightarrow \mathbb{R}$ , continuous at one point of  $\mathbb{R}$ , is locally bounded and so Theorem 1.1 applies. In order to show how the Cauchy equation translates properties, in particular properties at one point to pointwise ones, we give the following easy, direct proof. Eq (1) shows that if  $f$  is continuous at point  $x_0$ , then  $f$  is continuous at zero as is easy to see. (If  $\lim_{n \rightarrow \infty} y_n = 0$ , then  $f(x_0 + y_n) = f(x_0) + f(y_n)$ ; and  $\lim_{n \rightarrow \infty} f(x_0 + y_n) = f(x_0)$  implies  $\lim_{n \rightarrow \infty} f(y_n) = 0$ ). In turn, this implies that  $f$  is continuous at



every point  $x$  (If  $\lim_{n \rightarrow \infty} x_n = x$ , then  $f(x_n) = f(x_n - x + x) = f(x_n - x) + f(x)$

and  $\lim_{n \rightarrow \infty} f(x_n - x) = 0$ . Thus  $\lim_{n \rightarrow \infty} f(x_n) = f(x)$ ). Now, for a positive

integer  $p$ , we deduce  $f(px) = pf(x)$ . Due to  $f(-x) = -f(x)$ , the same result holds for any integer  $p$ . Similarly let  $q$  be a positive integer. From Eq (1), we write  $f(q\frac{x}{q}) = f(x) = qf(\frac{x}{q})$ . Then  $f(\alpha x) = \alpha f(x)$  for any rational  $\alpha$  and for all  $x$  in  $\mathbb{R}$ . Using the already proved continuity of  $f$  on the real axis, we thus get another proof for Corollary 1.1.

Corollary 1.2 Let  $f: \mathbb{R} \rightarrow \mathbb{R}$  be a function satisfying the Cauchy functional equation (1) for all  $x, y$  in  $\mathbb{R}$ . Suppose  $f$  is not continuous. For any non-empty open subset  $\theta$  of  $\mathbb{R}$ , the subset  $f(\theta)$  is dense in  $\mathbb{R}$ .

Suppose by contradiction that for some non-empty open subset  $\theta$  of  $\mathbb{R}$ , the subset  $f(\theta)$  is not dense in  $\mathbb{R}$ . There exists an open interval  $]a, b[$ ,  $a < b$ , such that  $f(\theta) \cap ]a, b[ = \emptyset$ . In other words, for every  $x$  in  $\theta$ , either  $f(x) \leq a$  or  $f(x) \geq b$ . Using the function  $g$ ,  $g(x) = f(x) - xf(1)$ , as in the proof of Theorem 1.1, and using possibly a smaller non-empty subset  $\theta'$ , included in  $\theta$ , with  $a' < b'$ , we get for every  $x$  in  $\theta'$ , either  $g(x) \leq a'$  or  $g(x) \geq b'$ . But as in Theorem 1.1, the function  $g$  is periodic and of period  $\frac{1}{n}$  for every positive integer  $n$ . For some positive integer  $n_0$ , an interval of length  $\frac{1}{n_0}$  is included in  $\theta'$  and so we deduce that for all  $x$  in  $\mathbb{R}$ , either  $g(x) \leq a'$  or  $g(x) \geq b'$ . At this point, we could use some manipulation to prove that  $g$  must have a constant sign and get a contradiction via Theorem 1.1. A direct proof is shorter. As  $f$  is not continuous, there

exists some  $x_0$  where  $g(x_0) \neq 0$ . The set of all  $rg(x_0)$ , when  $r$  runs through  $\mathbb{Q}$ , is dense in  $\mathbb{R}$ . As  $g(rx_0) = rg(x_0)$ , there exists some rational  $r_0$  and  $g(r_0 x_0) \in ]a', b'[$  which contradicts our inequalities.

Theorem 1.1 leads us to think that any slight regularity assumption concerning the solution of a Cauchy equation, at least on the real axis, implies in fact a strong regularity which in turn yields  $f(x) = ax$ .

Such appears to be the case and Cauchy solutions are either very regular or extremely pathological. (A pathology which is already described with Corollary 1.2).

We shall postpone the construction of pathological - but useful - solutions of Cauchy functional equations to Chapter IV (§3). The interest of the set of all Cauchy solutions will be seen in Chapter III (§5).

In the present chapter, we shall try to find various conditions concerning regularity for the Cauchy solutions.

## 1.2 A generalization

Theorem 1.2 Let  $f: \mathbb{R} \rightarrow \mathbb{R}$  be a function satisfying the Cauchy functional equation for all  $x, y$  in  $\mathbb{R}$ .

$$(1) \quad f(x+y) = f(x) + f(y)$$

Suppose that there exists a subset  $E$  of  $\mathbb{R}$  of (strictly) positive Lebesgue measure on which  $f$  is bounded above by a Lebesgue measurable function  $g: \mathbb{R} \rightarrow \mathbb{R}$ . There exists a constant  $a$  and  $f(x) = ax$  for all  $x$  in  $\mathbb{R}$ . In the sequel, a subset of positive Lebesgue measure obviously means its measure is strictly positive.

Proof As  $g: E \rightarrow \mathbb{R}$  is a Lebesgue measurable function, and as  $m(E)$ , the Lebesgue measure of  $E$ , is positive, there exists an integer  $n$  such that the subset  $E_n = \{x \in E; g(x) \leq n\}$  is of positive Lebesgue measure (As  $0 < m(E) = \lim_{n \rightarrow \infty} m(E_n)$ ). So, without loss of generality, we may suppose that there exists a subset  $E$  of  $\mathbb{R}$ , of (strictly) positive Lebesgue measure and a constant  $A$  such that

$$f(x) \leq A \quad \text{for all } x \text{ in } E$$

(We even may suppose that  $m(E)$  is finite which will prove technically useful).

Now, applying Eq (1) and defining  $F = E + E = \{z \in \mathbb{R}, z = x + y, x \in E, y \in E\}$ , we notice that  $f$  is bounded above by  $2A$  on  $F$

$$f(z) = f(x) + f(y) \leq 2A$$

If we prove (Lemma 1.1) that  $F$  contains an open and non-empty subset of  $\mathbb{R}$ , then using Theorem 1.1, we immediately deduce Theorem 1.2.

Lemma 1.1 Let  $E$  be a subset of  $\mathbb{R}$  of positive Lebesgue measure. Then  $F = E + E$  has non-empty interior.

First proof We may always suppose that  $E$  is of finite Lebesgue measure.

Then let us define  $\chi_E$ , the characteristic function of  $E$  ( $\chi_E(x) = 1$  if  $x \in E$  and  $0$  if  $x \notin E$ ). Clearly  $\chi_E$  is an element of  $L^1(\mathbb{R})$ , the Lebesgue space of all real-valued Lebesgue integrable functions on  $\mathbb{R}$ .

Compute  $h = \chi_E * \chi_E$ , that is

$$h(x) = \int_{\mathbb{R}} \chi_E(t) \chi_E(x-t) dt = \int_E \chi_E(x-t) dt$$

a) It is known (via Fubini's theorem) that  $h$  is an element of  $L^1(\mathbb{R})$ . Moreover, if  $x \notin F = E + E$ , then  $h(x) = 0$ . (As  $x - t \notin E$  for all  $t$  in  $E$  if  $x \notin F$ , then  $\chi_E(x-t) = 0$  for all  $t \in E$ . Thus, if  $x \notin F$ ,  $h(x) = \int_E \chi_E(x-t) dt = 0$ ). The set of all  $x$  in  $\mathbb{R}$  where  $h(x) \neq 0$  is included in  $E + E = F$ .

b) However,  $h$  is not almost everywhere equal to zero. A quick way to see this is to take the Fourier transform of  $h$

$$\hat{h}(y) = \int_{\mathbb{R}} e^{2i\pi y x} h(x) dx$$

and to notice that

$$\hat{h}(y) = (\hat{\chi}_E(y))^2.$$

due to the following computations which are justified by Fubini's theorem

$$\begin{aligned} \hat{h}(y) &= \int_{\mathbb{R}} e^{2i\pi y(x-t+t)} \left[ \int_{\mathbb{R}} \chi_E(t) \chi_E(x-t) dt \right] dx \\ &= \int_{\mathbb{R} \times \mathbb{R}} e^{2i\pi y(x-t)} \chi_E(x-t) e^{2i\pi y t} \chi_E(t) dx dt \\ &= \int_{\mathbb{R}} \chi_t(t) e^{2i\pi y t} dt \left[ \int_{\mathbb{R}} e^{2i\pi(x-t)y} \chi_E(x-t) dx \right] \\ &= \left( \int_{\mathbb{R}} \chi_t(t) e^{2i\pi y t} dt \right) \left( \int_{\mathbb{R}} e^{2i\pi x y} \chi_E(x) dx \right) = (\hat{\chi}_E(y))^2 \end{aligned}$$

$E$  being of positive Lebesgue measure,  $\chi_E$  is not in the zero class of



$L^1(\mathbb{R})$  and so  $\widehat{\chi_E}(y)$  is not the zero function as it is known that  $f \rightarrow \widehat{f}$  is an injection from  $L^1(\mathbb{R})$  into  $C_0(\mathbb{R})$ , the set of all continuous complex-valued functions over  $\mathbb{R}$ , tending to zero at infinity. (cf Bibliography). Thus  $\widehat{h}$  is not the zero function and so  $h$  itself is not zero in the Lebesgue sense, that is,  $h$  is not almost everywhere equal to zero.

c) We may even prove that  $h$  is a continuous function.

$$h(x+\alpha) - h(x) = \int_E (\chi_E(x+\alpha-t) - \chi_E(x-t)) dt$$

$$h(x+\alpha) - h(x) = \int_{[x]-E} (\chi_E(u+\alpha) - \chi_E(u)) du$$

where  $[x]-E$  denotes the set of all  $x-y$  with  $y$  in  $E$ . Thus

$$|h(x+\alpha) - h(x)| \leq \int_{\mathbb{R}} |\chi_E(u+\alpha) - \chi_E(u)| du$$

We have to estimate the last integral as  $\alpha$  goes to zero. First we estimate  $\chi_E$ . An  $\epsilon > 0$  being given, then there exists a continuous function  $c: \mathbb{R} \rightarrow \mathbb{R}$ , zero outside a bounded interval, such that

$$\int_{\mathbb{R}} |\chi_E(u) - c(u)| du \leq \epsilon$$

Then

$$\int_{\mathbb{R}} |\chi_E(u+\alpha) - \chi_E(u)| du \leq 2\epsilon + \int_{\mathbb{R}} |c(u+\alpha) - c(u)| du$$

Due to the uniform continuity of  $c$  on its bounded support, we may find

$\eta > 0$  such that for every  $\alpha$  with  $|\alpha| < \eta$ , we get  $\int_{\mathbb{R}} |c(u+\alpha) - c(u)| du < \epsilon$ .

We have proved the continuity of  $h$ .

Summarizing, we have obtained a non-empty open subset  $[x|h(x) \neq 0]$ , which is included in  $F = E + E$ . This proves lemma 1.1.

Second proof The previous proof of lemma 1.1 was chosen for its functional analysis flavour and the possibility of obtaining easy generalizations for any locally compact abelian topological group. However, on  $\mathbb{R}$  or on a metrizable topological group, a far shorter proof of a similar lemma reads as follows. It concerns now  $E - E = [x|x \in \mathbb{R} \ x = y - z; y \in E; z \in E]$ . Let  $E$  be a closed, bounded subset of  $\mathbb{R}$  with positive Lebesgue measure. We shall prove that  $E - E$  has a non-empty interior. There exists an open subset  $\theta \supset E$  such that  $\theta \cap E$  has Lebesgue measure strictly less than half of the Lebesgue measure of  $E$ . Let  $\delta = \inf_{\substack{z \in E \\ y \in \theta}} |z-y| > 0$  and let  $x$  be any real number such that  $|x| < \delta$ .

Clearly  $\theta \cap \mathcal{C}(E-x)$  has the same Lebesgue measure as  $\theta \cap E$  since  $E - x \subset \theta$  and since the Lebesgue measure is translation-invariant. Now  $\theta \cap (\mathcal{C}E \cap \mathcal{C}(E-x))$  has Lebesgue measure strictly less than the measure of  $E$ , and a fortiori less than the measure of  $\theta$ . Therefore  $E \cap (E-x)$  is not empty, which means that for every  $x$ ,  $|x| < \delta$ , there exists  $y \in E; z \in E$  and  $x = y - z$ . In other words  $]-\delta, +\delta[$  is included in  $E - E$ , or  $E - E$  contains a non-empty open interval. This kind of proof will be used in conjunction with a similar notion in topology, the one of Baire category (cf Chapter III, §2).

Corollary 1.3 A locally Lebesgue integrable function  $f: \mathbb{R} \rightarrow \mathbb{R}$ , satisfying Cauchy's equation is of the form  $f(x) \equiv ax$  for some  $a$  in  $\mathbb{R}$ .

Proof We may just quote Theorem 1.2, but a direct proof is of some interest. We integrate Eq (1):

$$\int_0^1 f(x+y)dy = \int_0^1 f(x)dy + \int_0^1 f(y)dy$$

Thus

$$\int_x^{x+1} f(t)dt = f(x) + \alpha, \text{ where } \alpha = \int_0^1 f(y)dy$$

As  $f$  is locally Lebesgue integrable, Eq (2) proves that  $f$  is continuous. Then Eq (2) in turn proves that  $f$  is differentiable. Differentiating both members of Eq (2), we get

$$f(x+1) - f(x) = f'(x)$$

But  $f(x+1) - f(x) = f(1)$ . Thus  $f(x) = f(1)x + \beta$ . Going back to Eq (1), we deduce  $\beta = 0$ . This kind of proof shall be used later to solve the so-called "tubular" case (cf Chapter V, §5).

A natural question arises once Theorem 1.2 is proved. Does there exist a characteristic property for a non-empty subset  $E$  of  $\mathbb{R}$  such that any Cauchy solution bounded above on  $E$  has to be of the form  $f(x) = xf(1)$ ? We shall solve this converse question in Chapter IV.

### 1.3 Some consequences

We shall now make additional algebraic assumptions to avoid any regularity hypothesis. In this vein, the most interesting result is the following easy one:

Corollary 1.4 All ring automorphisms from  $\mathbb{R}$  into  $\mathbb{R}$  are trivial.

A ring automorphism from  $\mathbb{R}$  into  $\mathbb{R}$  is a function  $f: \mathbb{R} \rightarrow \mathbb{R}$  such that both following functional equations hold for every  $x, y$  in  $\mathbb{R}$

$$(1) \quad f(x+y) = f(x) + f(y)$$

and

$$(3) \quad f(xy) = f(x)f(y)$$

Eq (3) provides us with  $f(x^2) = (f(x))^2$ , that is  $f(x) \geq 0$  for all  $x \geq 0$ . Theorem 1.1 immediately yields for some  $a$  in  $\mathbb{R}$ .

$$f(x) = ax$$

But equation (3) implies  $a(a-1) = 0$ . Either  $a = 1$  and so  $f(x) \equiv x$ , or  $a = 0$  and  $f(x) \equiv 0$ . These are the trivial automorphisms of  $\mathbb{R}$ . The complex situation is far different from the real one. We all know that  $z \rightarrow \bar{z}$  is an automorphism of  $\mathbb{C}$ . There even exist non continuous solutions of both Eq (1) and Eq (3) in the complex plane.

In the real case, we only used for Corollary 1.4, a positivity argument based on Eq (3). We may still expect some generalization by replacing Eq (3) with

$$(4) \quad f(x^m) = (f(x))^m$$

for a given positive integer  $m$ .

Clearly, if  $m$  is even, Eq (4) yields as well  $f(x) \geq 0$  for every  $x \geq 0$  and the same conclusion holds as in Corollary 1.4. What would happen if we were to take  $n$  to be an odd integer? To make things worse, what would happen if we were to restrict Eq (4) by only assuming its validity when both  $x > 0$  and  $f(x) > 0$ ?

Corollary 1.5 Let  $f: \mathbb{R} \rightarrow \mathbb{R}$  such that

$$(1) \quad f(x+y) = f(x) + f(y) \quad \text{for all } x, y \text{ in } \mathbb{R}.$$

For a given integer  $m$ , strictly greater than 1, let us suppose that

$$(4)' \quad (f(x^m)) = (f(x))^m \quad \text{for all } x \text{ such that both } x > 0 \text{ and } f(x) > 0 \text{ hold.}$$

Then  $f$  is continuous and either  $f(x) = x$  for all  $x$  in  $\mathbb{R}$  or there exists a real  $a$ ,  $a \leq 0$  and  $f(x) = ax$  for all  $x$  in  $\mathbb{R}$ .

We already noticed, in the second proof of Corollary 1.1, that an  $f$  satisfying (1) also satisfies  $f(\alpha x) = \alpha f(x)$  for any rational  $\alpha$  and for all  $x$  in  $\mathbb{R}$ . Let us start with  $m = 2$  in Corollary 1.5. First suppose the existence of some  $x_0, x_0 > 0$ , such that  $f(x_0) > 0$ . For each  $x$  in  $\mathbb{R}$ , and some sufficiently large rational  $\alpha$  ( $\alpha \geq \alpha_0, \alpha_0$  depending upon  $x$ ), we get  $x + \alpha x_0 > 0$  and  $f(x + \alpha x_0) = f(x) + \alpha f(x_0) > 0$ . Therefore Eq (4) applied to  $x + \alpha x_0$  in its restrictive domain of validity yields

$$f((x + \alpha x_0)^2) = (f(x + \alpha x_0))^2$$

and so for all rational  $\alpha \geq \alpha_0$

$$f(x^2) - (f(x))^2 = 2\alpha[f(x)f(x_0) - f(x)x_0].$$

Then  $f(x^2) = (f(x))^2$  for all  $x$  in  $\mathbb{R}$ , which is Eq (4) with  $m = 2$  and the restriction on its domain of validity removed (Eq (4)).

If no  $x_0 > 0$  with  $f(x_0) > 0$  exists, then  $f(x)$  has to be non positive for all  $x > 0$ . According to theorem 1.1, then there exists an  $a$  in  $\mathbb{R}$  and  $f(x) = ax$ . However, such an  $a$  must be non positive.

Clearly the same trick works for any integer  $m > 1$  as well as for  $m = 2$ , yielding  $f(x^m) = (f(x))^m$ . Therefore we now only have to solve simultaneously Eq (1) and Eq (4).

We have already proved Corollary 1.5 for even  $m$ . In the case where  $m$  is odd ( $m > 1$ ), we may reduce the problem to an even  $m$ , by using some linear combination of  $x$  and unity.

Using (4) and (1), we may expand  $f((\alpha x + \beta)^m)$  in two ways for two rational  $\alpha$  and  $\beta$ .

$$\begin{aligned} f((\alpha x + \beta)^m) &= \alpha^m f(x^m) + C_m^1 \alpha^{m-1} \beta f(x^{m-1}) + \dots + C_m^h \alpha^{m-h} \beta^h f(x^{m-h}) \\ &\quad + \dots + \beta^m f(1) \\ &= (\alpha f(x) + \beta f(1))^m \\ &= \alpha^m f(x^m) + C_m^1 \alpha^{m-1} \beta f(1) (f(x))^{m-1} + \dots + C_m^h \alpha^{m-h} \beta^h (f(1))^h (f(x))^{m-h} \\ &\quad + \dots + \beta^m (f(1))^m \end{aligned}$$

As  $\alpha$  and  $\beta$  are arbitrary rational numbers, by identification of the terms in  $\alpha^{m-1} \beta$  and  $\beta^m$ , we get  $f(1)(f(x))^{m-1} = f(x^{m-1})$  and  $(f(1))^m = f(1)$ . But  $m$  being odd, we get  $(f(x))^{m-1} \geq 0$  for all  $x$ .

We get now two cases :

If  $f(1) \geq 0$ , then  $f(x) \geq 0$

for all  $x \geq 0$  and if  $f(1) < 0$ , then  $f(x) \leq 0$  for all  $x \geq 0$ . In both

cases, Theorem 1.1 yields  $f(x) = f(1)x$  with  $(f(1))^m = f(1)$ . Thus  $f(1) = 0$ ,  $f(1) = -1$  or  $f(1) = 1$ , which ends the proof.

Note 1 If  $f$  is a Cauchy solution and satisfies Eq (4) with no restriction, then either  $m$  is even and we only have the trivial solutions  $(f(x) \equiv x; f(x) \equiv 0)$  or  $m$  is odd and we have the trivial ones plus  $f(x) \equiv -x$ .

Note 2 For the sake of completeness, we may try to look for a simultaneous solution of both Eq (1) and Eq (4) when  $m$  is any real number. However, for Eq (4) to make sense, when  $m$  is no longer an integer, we have to assume in addition that  $f(x) > 0$  for  $x > 0$ , and that Eq (4) holds for  $x > 0$  only. But then, from this condition Theorem 1.1 yields that  $f(x) = ax$  for some  $a$  in  $\mathbb{R}$ , and there is nothing new in such a system of equations. However if  $m$  is a negative integer, we only have to suppose  $f(x) \neq 0$  for Eq (4) to make sense. We then get

Corollary 1.6 Let  $f: \mathbb{R} \rightarrow \mathbb{R}$  be such that  $f$  is not identically 0 and

$$(1) \quad f(x+y) = f(x) + f(y) \quad \text{for all } x, y \text{ in } \mathbb{R}$$

and

$$(5) \quad f(x^m) = (f(x))^m \quad \text{for all } x \text{ such that } x \neq 0 \text{ and } f(x) \neq 0$$

where  $m$  is an integer different from 1 or 0. Then  $f(x) \equiv x$  or  $f(x) \equiv -x$ , the latter being possible only when  $|m|$  is odd.

When  $m$  is a positive integer, different from 0 or 1, Corollary 1.5 proves the result. When  $m$  is a negative integer, different from 0 or -1, then

for  $x \neq 0$  and  $f(x) \neq 0$  we get  $x^m \neq 0$ ,  $f(x^m) \neq 0$  so that

$$f(x^{m^2}) = f((x^m)^m) = (f(x^m))^m = (f(x))^{m^2}$$

and we are back to the positive integer case. Notice that  $m^2$  is odd if and only if  $|m|$  is odd. It only remains to treat the case  $m = -1$ . Eq (5) reads (and we suppose  $f$  to be non identically zero)

$$(6) \quad f\left(\frac{1}{x}\right) = \frac{1}{f(x)} \quad \text{for all } x \neq 0 \text{ and } f(x) \neq 0.$$

If for some  $x_0$ ,  $x_0 \neq 0$ , we get  $f(x_0) = 0$ , then Eq (6) applied to  $x = \frac{1}{x_0}$  shows by contradiction that also  $f\left(\frac{1}{x_0}\right) = 0$ . Now, we notice that  $|x + \frac{1}{x}| \geq 2$  for all  $x$  in  $\mathbb{R}/[0]$ . Therefore, using  $f(x + \frac{1}{x}) = f(x) + f\left(\frac{1}{x}\right) = f(x) + \frac{1}{f(x)}$ , we notice that for all  $x$ ,  $|x| \geq 2$ , we get either  $f(x) = 0$  or  $|f(x)| \geq 2$ . Corollary 1.2 immediately proves the continuity of  $f$ , that is  $f(x) = ax$  for some  $a$  in  $\mathbb{R}$ . Eq (6) yields  $a^2 = 1$ , which ends the proof of Corollary 1.6.

Note 3 If we were to replace Eq (4) by the same equation, but with absolute values on both sides, it can be proved that solutions of both Eq (1) and (7) will still be necessarily continuous, at least when  $m$  is an even integer.

$$(7) \quad |f(x^m)| = |f(x)|^m \quad \text{for all } x \neq 0, f(x) \neq 0, m \in \mathbb{Z} \\ m \neq 0; m \neq 1$$

The general solution for  $m \in \mathbb{R}$  remains to be found (with the restriction  $x > 0$  in Eq (7)) both for  $f: \mathbb{R} \rightarrow \mathbb{R}$  and  $f: \mathbb{R} \rightarrow \mathbb{C}$ .



1.4 Other algebraical conditions on Cauchy equations

Another natural candidate for a supplementary algebraic condition implying the continuity of a solution for the Cauchy equation is a behaviour like a derivation. For instance

$$(8) \quad f(x^2) = 2xf(x) \quad \text{or} \quad (9) \quad f\left(\frac{1}{x}\right) = -\frac{1}{x^2} f(x) \quad \text{for } x \neq 0$$

In case (8), using Eq (1), we deduce

$$f((x+y)^2) = f(x^2) + 2f(xy) + f(y^2) = 2(x+y)(f(x)+f(y))$$

and thus obtain a derivation

$$(10) \quad f(xy) = xf(y) + yf(x)$$

In the second case (9), using Eq (1), we deduce for  $x \neq 0$  and  $x \neq 1$

$$\begin{aligned} f\left(\frac{1}{x(x-1)}\right) &= -\frac{1}{x^2(x-1)^2} f(x(x-1)) = f\left(\frac{1}{x-1} - \frac{1}{x}\right) = f\left(\frac{1}{x-1}\right) - f\left(\frac{1}{x}\right) \\ &= -\frac{1}{(x-1)^2} f(x-1) + \frac{1}{x^2} f(x) \end{aligned}$$

which provides  $f(x^2) = 2xf(x) - x^2f(1)$ . But Eq (9) yields  $f(1) = 0$  and the last equation holds for all  $x$ . We are back to Eq (8) and to Eq (10) (from which also we deduce  $f(1) = 0$ ). There exist noncontinuous solutions of both Eq (10) and Eq (1). We postpone to Chapter VII the study of derivations. Let us just notice here that a change of sign in Eq (9) leads to a completely different answer.

Proposition 1.1 Let  $f: \mathbb{R} \rightarrow \mathbb{R}$  be a solution of both equations

$$(i) \quad f(x+y) = f(x) + f(y) \quad \text{for all } x, y \text{ in } \mathbb{R}$$

and

$$(ii) \quad f\left(\frac{1}{x}\right) = \frac{1}{x^2} f(x) \quad \text{for all } x \neq 0 \text{ in } \mathbb{R}$$

Then  $f$  is continuous and so  $f(x) \equiv ax$  for some  $a$  in  $\mathbb{R}$ . In the same way as with Eq (5), we deduce an equation

$$f(x^2) = 2xf(x) - x^2f(1)$$

The use of  $x + y$  in place of  $x$  yields

$$f(xy) = xf(y) + yf(x) - xyf(1)$$

With  $y = \frac{1}{x}$ ,  $x \neq 0$ , we deduce  $f(x) = xf(1)$ , which ends the proof of Proposition 1.1 as  $f(0) = 0$ .

1.5 Some vocabulary In order to solve Eq (1), we have made full use of the group properties of  $\mathbb{R}$ , as well as some topological or measure-theoretic properties. We shall try to make a distinction between the algebraical and the topological properties. To get a convenient vocabulary, we shall agree on the following definition.

Definition 1.1 A Cauchy functional equation is the functional equation satisfied by an homomorphism  $f$  between two groups  $G$  and  $F$ , i.e.

$$(1) \quad f: G \rightarrow F \quad f(x *_G y) = f(x) *_F f(y)$$

We shall then speak of a Cauchy solution for an  $f$  satisfying some Cauchy functional equation related to two groups. Sometimes, we shall use the word additive (when  $F, G$  are abelian groups) or multiplicative. We shall keep the word homomorphism when dealing with semi-groups, monoids, algebras, etc.

## 1.6 Cauchy inequality: suradditive functions

Along the line of Theorem 1.2, we might be tempted to replace the Cauchy functional equation by just an inequality, for example

$$(11) \quad f(x+y) \geq f(x) + f(y).$$

Such an inequality, or its converse, appears quite naturally in analysis. Take for example  $g: \mathbb{R} \rightarrow \mathbb{R}$ , a uniformly continuous function and define

$$f(y) = \sup_{0 \leq t \leq y} [\sup_{x \in \mathbb{R}} |g(x+t) - g(x)|]$$

It is not difficult to check that  $f: [0, \infty[ \rightarrow [0, \infty[$  satisfies

$$f(x+y) \leq f(x) + f(y)$$

for all  $x, y$  in  $[0, \infty[$ .

For a nice generalization of Theorem 1.2, the Cauchy inequality is not very convenient and we shall see later that an inequality of convexity, the so-called Jensen inequality, is far better (cf. Chapter IV, §6). However, the same result holds, as in Theorem 1.1, namely  $f(x) = ax$ , provided we say much more about the regularity of some functional bound for an unknown function satisfying the Cauchy inequality. A result in this direction is as follows.

Theorem 1.3 Let  $f: \mathbb{R} \rightarrow \mathbb{R}$  be a function satisfying for all  $x, y$  in  $\mathbb{R}$ , the functional inequality.

$$(11) \quad f(x+y) \geq f(x) + f(y)$$

Suppose that in some neighbourhood of a point  $x_0$ ,  $f$  is minimized by a function  $g$  such that  $g(x_0) = -f(-x_0)$ . Suppose moreover that  $g$  is differentiable at  $x_0$ . Then there exists a real constant  $a$  and for all  $x$  in  $\mathbb{R}$ .

$$f(x) = ax$$

Proof The function  $g$  provides a lower bound for  $f$ , let us say on  $I + x_0$  where  $I$  is an open interval containing the origin.

$$f(x) \geq g(x) \quad \forall x \in I + x_0$$

Our first step is to translate such an inequality into an equivalent one around the origin. Eq (11) yields with  $y = -x_0$

$$f(x-x_0) \geq g(x) + f(-x_0) \quad \forall x \in I + x_0$$

or, with  $G(x) = g(x+x_0) + f(-x_0)$

$$f(x) \geq G(x) \quad \forall x \in I$$

Moreover  $G(0) = g(x_0) + f(-x_0) = 0$ . Thus for all  $h$  in  $I$ , we get

$$f(x+h) - f(x) \geq f(h) \geq G(h)$$

and if we too suppose  $-h \in I$

$$f(x) = f(x+h-h) \geq f(x+h) + f(-h) \geq f(x+h) + G(-h)$$

so that

$$f(x+h) - f(x) \leq -G(-h)$$

Summarizing

$$-G(-h) \geq f(x+h) - f(x) \geq G(h)$$

With  $h > 0$  in  $I$ , we deduce

$$\frac{G(-h)}{-h} \geq \frac{f(x+h)-f(x)}{h} \geq \frac{G(h)}{h}$$

Analogous inequalities occur with  $h < 0$

$$\frac{G(-h)}{-h} \leq \frac{f(x+h)-f(x)}{h} \leq \frac{G(h)}{h}$$

As  $\lim_{h \rightarrow 0} \frac{G(h)}{h} = \lim_{h \rightarrow 0} \frac{G(-h)}{-h} = G'(0) = g'(x_0) = a$ , we deduce that  $f$  is

differentiable at every point  $x$  in  $\mathbb{R}$  and

$$f'(x) = a$$

Consequently  $f(x) = ax + b$  for all  $x$  in  $\mathbb{R}$ . Eq (11) implies  $b \leq 0$

but  $f(x_0) \geq -f(-x_0)$  implies  $b \geq 0$ . Therefore  $b = 0$ .

Theorem 1.3 is false if  $g$  is simply supposed to be continuous at a point  $x_0$ , or even on a neighbourhood of  $x_0$ . A counter-example is as follows. We take  $x_0 = 0$ ,  $f(0) = 0$  and  $f(x) = bx$  for all  $x \geq 0$ ,  $f(x) = ax$  for all  $x \leq 0$  and  $a > b > 0$ .

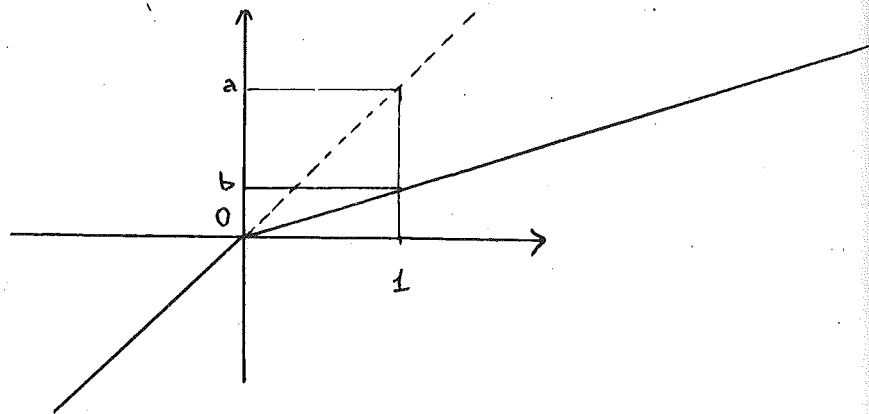

Such a function is continuous, non-linear and satisfies Eq (11) for all  $x, y$  in  $\mathbb{R}$ . (But it cannot be minorized locally at the origin by a differentiable function  $g$  such that  $g(0) = 0$ ).

To construct functions  $f$  satisfying (15) does not appear as difficult if we notice that  $x \rightarrow f(x) = \inf_{i \in I} (f_i(x))$  still satisfies

Eq (11) as soon as all  $f_i$  are solutions of Eq (11), where  $I$  is a non-empty set of indexes.

Taking the lower bound of a family of affine functions  $x \rightarrow a_i x + b_i$  with  $b_i \leq 0$ , we are then led to various solutions of Eq (11).

## CHAPTER II

## Some examples leading to conditional functional equations

Programme *On several occasions, in the investigation of functional equations or in applications to other mathematical domains, it has been observed that the family of solutions of the equation in question depends quite essentially on the domain in which the validity of the equation is postulated.*

*In traditional studies of functional equations the authors have usually assumed that the equation is fulfilled for all values of the variables from a certain set which appears natural for the equation. The Cauchy equation (1)  $f(x+y) = f(x) + f(y)$  is usually postulated for all  $(x,y) \in \mathbb{R} \times \mathbb{R}$  or more generally for all  $(x,y) \in G \times G$ , if we wish to work on a group.*

*However, in the recent decade, many investigations have been carried out, in which Eq (1) is postulated only on a certain non empty subset  $Z$  of  $G \times G$ .*

*This can occur for two main reasons: either the function  $f$  need not be defined on the whole of  $G$ , or, although the function  $f$  is defined on  $G$ , the equation need not hold for some pairs  $(x,y)$  in  $G \times G$ . In this chapter, we describe some problems, which originate from other branches of mathematics or from specific traditional functional equations and lead to equations like Cauchy equations; but on restricted domains. A name has been coined for such equations, which we shall study in Chapter III:*

Conditional Cauchy Equations

Other examples could be provided which lead to various kinds of conditional functional equations, but we shall mainly be concerned with conditional Cauchy equations.

### 2.1 Gauss' functional equation

In probability theory, it is interesting to determine all functions  $f: \mathbb{R} \rightarrow \mathbb{C}$  such that  $f(\sqrt{x^2+y^2}) = f(x)f(y)$  for all  $x, y$  in  $\mathbb{R}$ . As  $xoy = \sqrt{x^2+y^2}$  is associative,  $f$  is a homomorphism of the semi-group  $(\mathbb{R}, \circ)$  into the semi-group  $(\mathbb{C}, \cdot)$ . A general treatment of such homomorphisms is possible. At least, in the special case where we restrict  $f$  to take its values only in  $\mathbb{R}$ , there exists an easy way to solve the so-called Gauss' functional equation.

Theorem 2.1 A function  $f: \mathbb{R} \rightarrow \mathbb{R}$ , which is not identically zero for  $x \neq 0$ , which is continuous on a non-empty open subset of  $\mathbb{R}$  and which satisfies, for all  $x, y$  in  $\mathbb{R}$ , the Gauss functional equation

$$(2) \quad f(\sqrt{x^2+y^2}) = f(x)f(y)$$

is of the form  $f(x) = \exp(ax^2)$  for some  $a$  in  $\mathbb{R}$ .

Proof Eq (2) yields  $(f(0))^2 = f(0)$ . If  $f(0) = 0$ , we deduce that  $f(|x|) = 0$  for all  $x$  and so  $f(x) = 0$  for all  $x \geq 0$ . But  $(f(-x))^2 = f(\sqrt{2}|x|)$ , implying  $f \equiv 0$  which we reject. We may thus suppose  $f(0) = 1$ .

Let us first prove that  $f$  remains strictly positive. First,  $f$  is an even function ( $f(|y|) = f(0)f(y) = f(y)$ ). But  $f(\sqrt{2}|x|) = (f(x))^2$  which is positive or zero. We have thus proved  $f(x) \geq 0$  for all  $x \in \mathbb{R}$ .

Suppose now that  $x_0 = \text{Inf}[x | x \geq 0; f(x) = 0]$  exists. Then  $f(x_0) = (f(\frac{x_0}{\sqrt{2}}))^2$  and so  $f(\frac{x_0}{\sqrt{2}}) = 0$ . In other words, if  $f$  has a zero,  $x_0$  exists and must be equal to zero. However, if  $f(x_1) = 0$  with  $x_1 \geq 0$ , then  $f(x) = 0$  for all  $x \geq x_1$  as  $f(x) = f(\sqrt{x_1^2+y^2})$  with  $y = \sqrt{x^2-x_1^2}$  and  $f(x) = f(x_1)f(y) = 0$ . As  $x_0 = 0$ , if it exists, we get  $f(x) = 0$  for all  $x \neq 0$ , which we rejected. (It should here be mentioned that  $f(x) = 0$  if  $x \neq 0$  and  $f(0) = 1$  is a solution of the functional equation (2)).

We may suppose  $f(x) > 0$  for all  $x$  in  $\mathbb{R}$ . We then take the logarithm of  $f$  and define  $g(x) = \log f(x)$  to get a functional equation

$$(3) \quad g(\sqrt{x^2+y^2}) = g(x) + g(y)$$

where  $g(0) = 0$ , and  $g$  is an even function  $g: \mathbb{R} \rightarrow \mathbb{R}$ .

By induction, we prove  $g(nx) = n^2g(x)$  for all  $x$ . We start from

$$g(\sqrt{2}x) = 2g(x) \quad \text{for all } x \geq 0$$

and suppose  $g(\sqrt{nx}) = ng(x)$ . Then

$$\begin{aligned} g(\sqrt{(\sqrt{nx})^2 + x^2}) &= g(\sqrt{n+1}x) = g(\sqrt{nx}) + g(x) \\ &= ng(x) + g(x) = (n+1)g(x) \end{aligned}$$

With a change of variable, we have proved that for all  $x \geq 0$

$$g(nx) = n^2g(x)$$

As  $g$  is even, the same result holds for all  $x$  and for both positive

and negative integers  $n$ .

We prove now that  $g(rx) = r^2g(x)$  for all  $x$  in  $\mathbb{R}$  and all rational numbers  $r$ .

We start from  $g(mx)$  written as  $g(n \frac{mx}{n})$ :

$$\begin{aligned} g(n \frac{mx}{n}) &= n^2 g(\frac{m}{n} x) \\ &= g(mx) = m^2 g(x) \quad \text{which yields} \\ g(\frac{m}{n} x) &= \frac{m^2}{n^2} g(x) \end{aligned}$$

Using  $x = 1$ , we get  $g(r) = r^2g(1)$  for all rationals.

Let  $\theta$  be the non-empty open subset of  $\mathbb{R}$  on which  $f$  (and consequently  $g$ ) was supposedly continuous. By continuity, we deduce that  $g(x) = x^2g(1)$  for all  $x$  in  $\theta$ . However, let  $x$  be any non zero real number. As  $x\mathbb{Q}$  is dense in  $\mathbb{R}$ ,  $\mathbb{Q}x \cap \theta \neq \emptyset$ . Then there exists  $t \in \theta$  and a rational  $r$  such that  $x = rt$ .

$$g(x) = g(rt) = r^2g(t) = r^2t^2g(1) = x^2g(1)$$

Such a result still holds for  $x = 0$ . We now define  $a = g(1)$

( $a \in \mathbb{R}$ ), and going back to  $f$ , get

$$f(x) = e^{ax^2} \quad \text{for all } x \text{ in } \mathbb{R}.$$

Theorem 2.1 remains valid if, instead of the assumption of the continuity, we use a boundedness assumption on  $f$ . Namely

Theorem 2.2 A function  $f: \mathbb{R} \rightarrow \mathbb{R}$ , which is not identically 0 for  $x \neq 0$ , bounded on a non empty open subset  $\theta$  of  $\mathbb{R}$  and satisfying for all  $x, y$  in  $\mathbb{R}$  the Gauss' equation

$$(2) \quad f(\sqrt{x^2+y^2}) = f(x)f(y)$$

is of the form  $f(x) = e^{ax^2}$  for some  $a \in \mathbb{R}$ .

Let us sketch the proof which is analogous to the one used in Theorem 1.2, the notations of which we maintain here. Due to the evenness of  $g$ , we may suppose that  $\theta \cap [0, \infty[ \neq \emptyset$  and in fact we shall only work on  $[0, \infty[$  [i.e.  $\theta \neq \emptyset \subset [0, \infty[$ ]. Without loss of generality we may suppose that  $\theta$  is bounded and  $|g(x)| \leq A$  for all  $x$  in  $\theta$ . Define then  $X_0 = \sup_{t \in \theta} t$  and put  $h(x) = g(x) - x^2g(1)$ . Clearly  $h(0) = 0$ ;  $h(1) = 0$  and  $h$  too satisfies Eq (3). Moreover  $h$  is bounded by a certain  $B$  in  $\theta$ . With  $h(1) = 0$ , we deduce that  $h(r) = 0$  for every rational number  $r$ . For such a rational  $r$ , we get

$$h(\sqrt{x^2+r^2}) = h(x) + h(r) = h(x)$$

For a given  $x \geq 0$ , as  $r$  runs through  $\mathbb{Q}$ ,  $\sqrt{x^2+r^2}$  is dense in  $[x, \infty[$ . Thus, if  $0 \leq x \leq X_0$ , for some  $r$ ,  $\sqrt{x^2+r^2}$  belongs to  $\theta$  and so  $|h(x)| \leq B$ . Now, for  $x > X_0$ , there exists  $t \in \theta$  and  $r \in \mathbb{Q}$  such that  $\sqrt{t^2+r^2} = x$ . Thus  $|h(x)| = |h(t)| \leq B$ . Summarizing, we have proved that for all  $x$

$$(4) \quad |h(x)| \leq B$$

But we obtained  $h(rx) = r^2h(x)$  for all rational  $r$ , which yields  $h(x) \equiv 0$  due to (4). This ends the proof of Theorem 2.2. We could improve the conditions given in Theorem 2.2, in the same fashion as Theorem 1.2 will be improved (See Chapter IV, §4).

We may ask now what happens when  $f$  is allowed to take on complex values. During the proof, we shall see the appearance of a conditional Cauchy equation.

Theorem 2.3 Let  $f: \mathbb{R} \rightarrow \mathbb{C}$  be a continuous function, not identically 0 and satisfying

$$(2) \quad f(\sqrt{x^2+y^2}) = f(x)f(y)$$

Then there exists  $a \in \mathbb{C}$  such that  $f(x) = e^{ax^2}$ .

Proof As in the real-valued case,  $f$  is nowhere equal to zero. Thus, by continuity, we may choose two continuous functions

$$h: [0, \infty[ \rightarrow ]0, \infty[$$

and

$$g: [0, \infty[ \rightarrow \mathbb{R}$$

such that  $f(\sqrt{x}) = h(x)\exp ig(x) \quad \forall x \in [0, \infty[$

Eq (2) becomes, using new variables  $x^2 = s, y^2 = t$  where  $s, t \in [0, \infty[$ ,

$$h(s+t)\exp ig(s+t) = h(s)h(t)\exp i(g(s) + g(t))$$

which yields

$$(5) \quad h(s+t) = h(s)h(t) \quad s, t \in [0, \infty[$$

and

$$(6) \quad g(s+t) = g(s) + g(t) \pmod{2\pi}; s, t \in [0, \infty[$$

As  $h > 0$ , taking the logarithms of both members in Eq (5), we obtain a conditional Cauchy equation for  $H(s) = \log h(s)$  (as the equation is only defined for non-negative numbers and not on the whole additive group of real numbers).

$$(7) \quad H(s+t) = H(s) + H(t) \quad \forall s, t \in [0, \infty[ \\ H: [0, \infty[ \rightarrow \mathbb{R}$$

We shall prove later that due to the continuity of  $H$ , there exists  $b \in \mathbb{R}$  and  $H(s) = bs$  for all  $s \in [0, \infty[$  (cf Chapter IV, §1). Eq (6) is too a conditional Cauchy equation with  $G: \mathbb{R}_+ = [0, \infty[ \rightarrow \overline{\mathbb{T}} = \frac{\mathbb{R}}{2\pi\mathbb{Z}}$  that is taking its values in the torus  $\overline{\mathbb{T}}$ , which is an abelian group.

$$(8) \quad G(s+t) = G(s) + G(t) \quad \forall s, t \in [0, \infty[ \\ G = [0, \infty[ \rightarrow \overline{\mathbb{T}}$$

Continuity of  $G$  provides the tool for solving such an equation. In fact we shall write Eq (6) in the form

$$g(s+t) = g(s) + g(t) + 2\pi h(s,t)$$

where  $h(s,t)$  belongs to  $\mathbb{Z}$ . However  $h: [0, \infty[ \times [0, \infty[ \rightarrow \mathbb{Z}$  is also continuous and thus must be constant; i.e.  $h(s,t) = h$ .

We then use

$$J(s) = g(s) + 2h\pi$$

to obtain

$$(9) \quad J(s+t) = J(s) + J(t)$$

$$J: [0, \infty[ \rightarrow \mathbb{R}$$

As already explained, there exists  $c$  in  $\mathbb{R}$  and

$$J(s) = cs$$

Returning to  $f$  we get that for all  $x \geq 0$

$$f(\sqrt{x}) = e^{bx} e^{icx+2ih\pi} \\ = e^{(b+ic)x}$$



We define  $a = b + ic$  where  $a \in \mathbb{C}$  and

$$f(x) = e^{ax^2} \quad \text{for all } x \geq 0$$

Such a result holds for all  $x$  in  $\mathbb{R}$  due to the evenness of  $f$ . It ends the proof of Theorem 2.3.

It is possible to improve Theorem 2.3 but our aim was only to explain the occurrence of conditional Cauchy equations. The same kind of conditional Cauchy equations would occur if we were to generalize Gauss' functional equation. Let  $\circ$  denote a binary and associative law on  $\mathbb{R}$ . We are led to find all  $f: \mathbb{R} \rightarrow \mathbb{C}$  such that for all  $x$  and  $y$  in  $\mathbb{R}$ , we get

$$f(x \circ y) = f(x)f(y)$$

(See bibliography).

## 2.2 Mikusinski's functional equation

A problem encountered in geometrical optics and a fundamental one in affine geometry is that of finding all bijective mappings  $T: \mathbb{R}^2 \rightarrow \mathbb{R}^2$  which map straight lines into straight lines. The same classical problem can be asked with affine spaces of dimension  $n$  on fields different from  $\mathbb{R}$ . For the sake of notational simplicity only, we shall restrict ourselves to the two dimensional case. Clearly as  $T$  is surjective,  $T$  maps parallel lines into parallel lines and so transforms a parallelogram into another one. We write  $T(x,y)$  as  $(F(x,y), G(x,y))$ , and without loss of generality we may suppose that  $G(0,0) = F(0,0) = 0$ .

Recall that the colinearity of three points of the euclidean plane:  $M_1(x_1, y_1)$ ;  $M_2(x_2, y_2)$  and  $M_3(x_3, y_3)$ , can be expressed by the vanishing of the determinant.

$$\begin{vmatrix} x_1 & x_2 & x_3 \\ y_1 & y_2 & y_3 \\ 1 & 1 & 1 \end{vmatrix} = 0$$

As  $(0,0)$ ;  $(1,0)$  and  $(x,0)$  are colinear, we get

$$\begin{vmatrix} G(0,0) & G(1,0) & G(x,0) \\ F(0,0) & F(1,0) & F(x,0) \\ 1 & 1 & 1 \end{vmatrix} = \begin{vmatrix} G(1,0) & G(x,0) \\ F(1,0) & F(x,0) \end{vmatrix} = 0$$

or a first functional equation

$$(1) \quad aF(x,0) = bG(x,0)$$

with  $G(1,0) = a$ ,  $F(1,0) = b$  and  $|a| + |b| \neq 0$ . As  $(0,0)$ ,  $(0,1)$  and  $(0,y)$  are colinear, we get in the same way

$$(2) \quad cF(0,y) = dG(0,y) \quad \text{with } |c| + |d| \neq 0$$

As the four points  $(0,0)$ ,  $(x,0)$ ,  $(0,y)$  and  $(x,y)$  form a parallelogram, we get a system of two functional equations

$$(3) \quad \begin{cases} F(x,y) = F(x,0) + F(0,y) \\ G(x,y) = G(x,0) + G(0,y) \end{cases}$$

Combining (1), (2) and (3), we deduce that

$$(4) \quad d[bG(x,y) - aF(x,y)] = d(bG(0,y) - aF(0,y)) = (bc-ad)F(0,y)$$

We shall suppose for concreteness  $b \neq 0$  and  $d \neq 0$ . Due to Eq (4), as  $T$  is bijective,  $bc - ad \neq 0$ . Other functional equations are needed.

As  $x$  runs through  $\mathbb{R}$ ,  $(x,x)$  determines a line and so  $(F(x,x), G(x,x))$  does as well. Hence there exist real constants  $\alpha, \beta$  with  $|\alpha| + |\beta| \neq 0$ , such that

$$\alpha F(x,x) + \beta G(x,x) = 0$$

Then  $\alpha F(x,0) + \alpha F(0,x) + \beta G(x,0) + \beta G(0,x) = 0$ .

Eq (1) and Eq (2) yield

$$\alpha F(x,0) + \beta \frac{a}{b} F(x,0) + \alpha F(0,x) + \beta \frac{c}{d} F(0,x) = 0$$

or

$$d(\alpha b + \beta a)F(x,0) + (\alpha d + \beta c)b F(0,x) = 0$$

As  $b \neq 0$ ,  $d \neq 0$ ,  $ad - bc \neq 0$ , and  $|\alpha| + |\beta| \neq 0$  both coefficients of the

preceding equation are not simultaneously equal to zero. But if one is equal to zero, we get either  $F(0,x) = 0$ , which is impossible due to (4), or  $F(x,0) = 0$  and as  $b \neq 0$ , also  $G(x,0) = 0$ , which contradicts the bijectivity of  $T$ . Thus we may write  $F(0,x) = eF(x,0)$  with  $e \neq 0$ . We define a new function  $f(x) = F(x,0)$ , which we shall try to determine through a unique functional equation.

As  $(x+y,0)$ ,  $(x,y)$  and  $(0,x+y)$  are colinear, we get

$$0 = \begin{vmatrix} F(x+y,0) & F(x,y) & F(0,x+y) \\ G(x+y,0) & G(x,y) & G(0,x+y) \\ 1 & 1 & 1 \end{vmatrix}$$

i.e.

$$0 = \begin{vmatrix} f(x+y) & f(x) + ef(y) & ef(x+y) \\ \frac{a}{b} f(x+y) & \frac{a}{b} f(x) + e\frac{c}{d} f(y) & \frac{c}{d} ef(x+y) \\ 1 & 1 & 1 \end{vmatrix}$$

$$0 = \begin{vmatrix} f(x+y) & f(x) + ef(y) & (e-1)f(x+y) \\ ad f(x+y) & ad f(x) + ebc f(y) & (ebc-ad)f(x+y) \\ 1 & 1 & 0 \end{vmatrix}$$

$$0 = f(x+y) \begin{vmatrix} f(x+y) & f(x) + ef(y) - f(x+y) & (e-1) \\ ad f(x+y) & ad f(x) - ad f(x+y) + ebc f(y) & ebc - ad \\ 1 & 0 & 0 \end{vmatrix}$$

$$\begin{aligned}
0 &= f(x+y)[(e(bc-ad)(f(x) + ef(y) - f(x+y)) - (e-1)(adf(x) - adf(x+y) + ebcf(y)))] \\
&= f(x+y)[f(x)(e(bc-ad)-ead+ad) + f(y)(e(ebc-ad)-(e-1)ebc) + f(x+y)[(e-1)ad-ebc+ad]]
\end{aligned}$$

Finally, we get

$$0 = f(x+y)[-f(x+y) + f(x) + f(y)]e(bc-ad)$$

Thus

$$(5) \quad f(x+y)[f(x+y) - f(x) - f(y)] = 0$$

This equation (5) amounts to a conditional Cauchy equation, the so-called Mikusinski equation (6), as this author was the first to propose this method for solving in a quick way the fundamental theorem of affine geometry

$$(6) \quad \begin{aligned} &f: \mathbb{R} \rightarrow \mathbb{R} \\ &f(x+y) = f(x) + f(y) \quad \text{if } f(x+y) \neq 0 \end{aligned}$$

We shall solve later such a functional equation (cf Theorem 5.1) and prove that in the case of  $\mathbb{R}$ ,  $f$  satisfies the Cauchy equation everywhere. A longer analysis would prove that in fact  $f$  has to be linear, i.e.  $f(x) = ax$  for some  $a \neq 0$  in  $\mathbb{R}$  and therefore that  $T$  is a nonsingular linear transformation (In the case of affine spaces,  $f$  would only be semi-linear). We shall here merely point out that some mild regularity assumption over  $T$  shortens the proof so that we can state

Theorem 2.4 Let  $T: \mathbb{R}^2 \rightarrow \mathbb{R}^2$  be a bijection keeping colinearity and continuous at a point. Then  $T$  is the composition of a translation and of a non singular linear transformation.

### 2.3 A conditional Cauchy equation

Let  $L^1(\mathbb{R})$  be the Banach space of all equivalence classes of Lebesgue integrable functions  $f: \mathbb{R} \rightarrow \mathbb{C}$  equipped with the norm

$$\|f\|_1 = \int_{\mathbb{R}} |f(x)| dx$$

As is well known, the function  $f * g$ , for  $f$  and  $g$  in  $L^1(\mathbb{R})$ , defined as

$$f * g(x) = \int_{\mathbb{R}} f(t)g(x-t) dt$$

is an element of  $L^1(\mathbb{R})$ . Moreover,  $*$  transforms  $L^1(\mathbb{R})$  into a complex Banach algebra.

An important feature of such an algebra is the set of all linear non-zero multiplicative functionals on  $L^1$ , i.e. the spectrum of the Banach algebra  $L^1(\mathbb{R})$ . It is the set of all  $F$  such that  $F \neq 0$ ,

$$\begin{aligned}
F: L^1(\mathbb{R}) \rightarrow \mathbb{C} \quad \text{and} \quad F(\lambda f + \mu g) &= \lambda F(f) + \mu F(g) \\
F(f * g) &= F(f) F(g)
\end{aligned}$$

It turns out first that a linear and multiplicative functional on  $L^1(\mathbb{R})$  is bounded (See bibliography for a proof of this classical result). Therefore, by a duality theorem, there exists an  $h: \mathbb{R} \rightarrow \mathbb{C}$  where  $h$  is essentially bounded ( $h \in L^\infty(\mathbb{R})$  and  $h$  is not 0 a.e) such that

$$F(f) = \int_{\mathbb{R}} f(x)h(x) dx$$

Turning back to the multiplicative condition, we get

$$\int_{\mathbb{R}} h(x) \left[ \int_{\mathbb{R}} f(t) g(x-t) dt \right] dx = \left[ \int_{\mathbb{R}} h(t) f(t) dt \right] \left[ \int_{\mathbb{R}} h(u) g(u) du \right]$$

which we may write in a different way

$$\begin{aligned} \int_{\mathbb{R}} h(x) \left[ \int_{\mathbb{R}} f(t) g(x-t) dt \right] dx &= \int_{\mathbb{R}} f(t) \left[ \int_{\mathbb{R}} h(x) g(x-t) dx \right] dt \\ &= \int_{\mathbb{R}} f(t) \left[ \int_{\mathbb{R}} h(u+t) g(u) du \right] dt \end{aligned}$$

and so, using a double integral

$$\iint_{\mathbb{R} \times \mathbb{R}} f(t) g(u) [h(u+t) - h(u)h(t)] du dt = 0$$

From the fact that the space of all linear combinations of functions of the form  $f(t)g(u)$  is dense in  $L^1(\mathbb{R}^2)$  [generalized Stone-Weierstrass theorem for  $L^2(\mathbb{R}^2)$ ], we deduce that

$$h(u+t) = h(u)h(t) \quad \text{in the sense of } L^\infty(\mathbb{R}^2)$$

i.e.

$$(1) \quad h(u+t) = h(u)h(t) \quad \text{almost everywhere in } \mathbb{R}^2$$

Eq (1) is in fact a conditional Cauchy equation  $h: \mathbb{R} \rightarrow C/[0]$ , where  $\mathbb{R}$  is the usual additive group and  $C/[0]$  is the complex multiplicative group. (If  $h$ , satisfying (1), is equal to zero on a set of strictly positive Lebesgue measure, then  $h = 0$  a.e., which we reject. Thus we may modify  $h$  on a set of measure zero so that  $h$  keeps its values in  $C/[0]$ , and still satisfies (1) almost everywhere in  $\mathbb{R}^2$ ). In Chapter V, §5, we shall prove the following result.

If a function  $h: \mathbb{R} \rightarrow \mathbb{C}$  satisfies (1) a.e. in  $\mathbb{R}^2$ , there exists a unique function  $H: \mathbb{R} \rightarrow \mathbb{C}$  satisfying the equation (1) everywhere and  $H = f$  a.e.

It is now required to solve the equation

$$(2) \quad H(x+t) = H(x)H(t) \quad H: \mathbb{R} \rightarrow \mathbb{C}$$

under the conditions that  $H \in L^\infty(\mathbb{R})$  and  $H$  is not in the equivalence class of the zero function. We clearly get  $H(0) = 1$  (as  $H$  is not identically equal to 0 a.e.) and  $H(x) \neq 0$  for any  $x \in \mathbb{R}$  (as  $1 = H(x)H(-x)$ ). First, take the modulus of  $H$ , writing  $G(x) = |H(x)|$ . The function  $G$  is strictly positive and so  $\log G$  satisfies the conditions of Theorem 1.1, as  $H$  is in  $L^\infty(\mathbb{R})$ . We then get  $|H(x)| = e^{ax}$  for some  $a \in \mathbb{R}$ . However  $H \in L^\infty(\mathbb{R})$  implies that  $a = 0$  and so  $|H(x)| \equiv 1$ . We may now find a measurable function  $\alpha: \mathbb{R} \rightarrow \mathbb{R}$  such that

$$H(x) = e^{i\alpha(x)}$$

In fact, function  $\alpha$  satisfies a Cauchy equation, but from  $\mathbb{R}$  into the group  $\mathbb{R}/2\pi\mathbb{Z}$  as

$$(3) \quad \alpha(x+t) = \alpha(x) + \alpha(t) \pmod{2\pi}$$

We write

$$\alpha(x+t) = \alpha(x) + \alpha(t) + 2\pi h(s,t)$$

where  $h(s,t) \in \mathbb{Z}$ . As  $h$  is a measurable function and  $\bigcup_{n=-\infty}^{+\infty} A_n = \mathbb{R}^2$  with  $A_n = [s,t | s \in \mathbb{R}, t \in \mathbb{R}, h(s,t) = n]$ , there exists a  $n_0$  such that  $A_{n_0}$  is of strictly positive Lebesgue measure. Thus the function  $\beta$ , where

$\beta(t) = \alpha(t) + 2\pi n_0 t$ , satisfies both equation (3) and (4)

$$(4) \quad \beta(x+t) = \beta(x) + \beta(t) \quad \text{for } (x,t) \in Z$$

where  $Z$  is of strictly positive Lebesgue measure. Eq (4) is typically a conditional Cauchy equation which shall be dealt with in Chapter V. We shall then deduce that there exists a constant, which we take for convenience to be  $2\pi a$ , such that

$$\alpha(x) = 2\pi ax + 2n_0\pi$$

[We could avoid Eq (4) by reasoning directly on  $H$ . Using Eq (2), as  $H \in L^\infty(\mathbb{R})$  is locally integrable, and dealing in exactly the same way as in the proof of Corollary 1.3, we deduce that  $H$  is in fact continuous. Then we can choose a continuous  $\alpha$  such that  $H(x) = e^{i\alpha(x)}$  and as in Theorem 2.3, we obtain that

$$\alpha(x) = 2\pi ax + 2\pi n_0]$$

Going back to  $F$ , we have obtained that

$$F(f) = \int_{\mathbb{R}} f(x) e^{2i\pi ax} dx = \hat{f}(a)$$

It is clear that for  $a_1 \neq a_2$ , there exists  $f \in L^1(\mathbb{R})$  such that  $\hat{f}(a_1) \neq \hat{f}(a_2)$ . Therefore, we have proved the following theorem.

Theorem 2.5 The spectrum of  $L^1(\mathbb{R})$ , as a convolution algebra, can be identified with the set of real numbers via

$$\begin{aligned} f &\rightarrow \hat{f}(y) & y &\in \mathbb{R} \\ L^1(\mathbb{R}) &\rightarrow \mathbb{C} \end{aligned}$$

Theorem 2.5 can be generalized to any locally compact abelian group and is a way of introducing the dual group  $\hat{G}$  of such a group  $G$  (For  $\mathbb{R}$ ,  $\hat{\mathbb{R}} = \mathbb{R}$ ). It is a fundamental result in abstract harmonic analysis. Therefore the generalized conditional Cauchy equation (1) has to be solved in the case of any locally compact abelian group (cf Chapter V, §6). When we take the set of all real numbers, equipped with the discrete topology  $\mathbb{R}$ , then the dual group  $\mathbb{R}^\wedge$  is a compact and abelian topological group, the so-called Bohr group of  $\mathbb{R}$ . We shall study this Bohr group later and shall use a different way, with the help of Bohr almost periodic functions and the set of all solutions of some Cauchy equation (cf Chapter III §5).

## 2.4 Jensen functional equation

Let  $[a, b]$  be a given interval of  $\mathbb{R}$ . We look for the functions  $f: [a, b] \rightarrow \mathbb{R}$  which preserve midpoints, i.e.

$$(1) \quad f\left(\frac{x+y}{2}\right) = \frac{f(x)+f(y)}{2} \quad \forall x, y \in [a, b]$$

Theorem 2.6 Let  $f: [a, b] \rightarrow \mathbb{R}$  be a continuous function satisfying Eq (1).

Then, there exists  $\alpha, \beta$ , real numbers, such that

$$f(x) = \alpha x + \beta$$

Proof Let us define  $F: [0, 1] \rightarrow \mathbb{R}$  by  $F(y) = f[(b-a)y+a]$ . Then  $F$  also satisfies Eq (1):

$$\begin{aligned} F\left(\frac{x+y}{2}\right) &= f\left[\frac{(b-a)(x+y)+2a}{2}\right] = f\left(\frac{(b-a)x+a+(b-a)y+a}{2}\right) \\ &= \frac{f((b-a)x+a)+f((b-a)y+a)}{2} = \frac{F(x)+F(y)}{2} \end{aligned}$$

We define  $F(0) = \gamma$  and  $F(1) = \delta$ .

Then

$$F\left(\frac{1}{2}\right) = \frac{\gamma+\delta}{2} = \gamma + \frac{\delta-\gamma}{2}$$

$$F\left(\frac{1}{4}\right) = \frac{F(0)+F\left(\frac{1}{2}\right)}{2} = \frac{\gamma+\gamma+\frac{\delta-\gamma}{2}}{2} = \gamma + \frac{\delta-\gamma}{4}$$

$$F\left(\frac{3}{4}\right) = \frac{F\left(\frac{1}{2}\right)+F(1)}{2} = \frac{\gamma+\frac{\delta-\gamma}{2}+\delta}{2} = \gamma + \frac{3}{4}(\delta-\gamma)$$

More generally, it may be shown by induction that for  $x = \frac{h}{2^n}$ , where  $h$  is an integer such that  $0 \leq h \leq 2^n$ , we get

$$(2) \quad F(x) = \gamma + x(\delta-\gamma)$$

Let us check (2) for  $\frac{h}{2^{n+1}}$ , and for this we consider two cases  $\frac{2h}{2^{n+1}}$  and  $\frac{2h+1}{2^{n+1}}$ .

$$F\left(\frac{2h}{2^{n+1}}\right) = F\left(\frac{h}{2^n}\right) = \gamma + \frac{h}{2^n}(\delta-\gamma) = \gamma + \frac{2h}{2^{n+1}}(\delta-\gamma)$$

$$\begin{aligned} F\left(\frac{2h+1}{2^{n+1}}\right) &= F\left(\frac{1}{2}\left(\frac{h}{2^n} + \frac{h+1}{2^n}\right)\right) = \frac{1}{2}\left[F\left(\frac{h}{2^n}\right) + F\left(\frac{h+1}{2^n}\right)\right] \\ &= \frac{1}{2}\left[\gamma + \frac{h}{2^n}(\delta-\gamma) + \gamma + \frac{h+1}{2^n}(\delta-\gamma)\right] \\ &= \gamma + \frac{2h+1}{2^{n+1}}(\delta-\gamma) \end{aligned}$$

Eq (2) is then valid for all dyadic numbers, that is for all numbers of the form  $x = \frac{h}{2^n}$ , where  $h$  is an integer such that  $0 \leq h \leq 2^n$  and where  $n$  is a positive integer. Such dyadic numbers form a dense subset of  $[0, 1]$ . As  $F$  is continuous over  $[0, 1]$ , Eq (2) is valid for all  $x$  in  $[0, 1]$ . Going back to  $f$ , we get

$$f(x) = F\left(\frac{x-a}{b-a}\right) = \gamma + \frac{x-a}{b-a}(\delta-\gamma) = \alpha x + \beta \quad \text{with } \alpha, \beta \in \mathbb{R}$$

which ends the proof of Theorem 2.6.

We could have tried to prove theorem 2.6 in a more lazy way. Let us suppose, to begin with, that  $0 \in [a, b]$ . Such an assumption can always be made without loss of generality, using a convenient change of variables like the one we did to go from  $f$  to  $F$ . Let  $y = 0$  in

Eq (1). We get

$$f\left(\frac{x}{2}\right) = \frac{1}{2}f(x) + \frac{\alpha}{2} \text{ where } \alpha = f(0)$$

Thus Eq (1) becomes for  $x + y \in [a, b]$ ,  $x \in [a, b]$  and  $y \in [a, b]$

$$f\left(\frac{x+y}{2}\right) = \frac{f(x+y)}{2} + \frac{\alpha}{2} = \frac{f(x)}{2} + \frac{f(y)}{2}$$

or

$$f(x+y) = f(x) + f(y) - \alpha$$

With  $g(x) = f(x) - \alpha$ , we get a conditional Cauchy equation

$$(3) \quad g(x+y) = g(x) + g(y)$$

valid for all  $x, y$  in  $[a, b]$  such that too  $x + y \in [a, b]$ . The general solution of Eq (3) shall later come as a consequence of more general results (cf Chapter IV §2) and will provide us with another proof for Theorem 2.6 (with even far less regularity assumptions). However, focussing on the conditional Cauchy equation (3), or a slightly less general one, we shall see how conversely Theorem 2.6 leads to its solution which is interesting in itself (See Corollary 4.4 for a generalization).

Theorem 2.7 Let  $g: \mathbb{R} \rightarrow \mathbb{R}$  be a continuous function satisfying the Cauchy conditional equation:  $g(x+y) = g(x) + g(y)$ , for all  $x, y$  in  $[a, b]$ .

If  $[a, b] \cap [2a, 2b] \neq \emptyset$ , there exists  $\alpha \in \mathbb{R}$  and  $g(x) = \alpha x$  for all  $x \in [a, b] \cup [2a, 2b]$ .

If  $[a, b] \cap [2a, 2b] = \emptyset$ , there exist  $\alpha, \beta$  in  $\mathbb{R}$  and  $g(x) = \alpha x + \beta$  for all  $x \in [a, b]$ ,  $g(x) = \alpha x + 2\beta$  for all  $x \in [2a, 2b]$ .

Proof Let  $t \in [2a, 2b]$  and  $x = y = \frac{t}{2}$ . Using Eq (3) we get

$$g(t) = 2g\left(\frac{t}{2}\right)$$

For any  $t \in [2a, 2b]$ , such that  $t = x + y$ , with  $x, y \in [a, b]$

$$\begin{aligned} g\left(\frac{x+y}{2}\right) &= \frac{g(x+y)}{2} \\ &= \frac{g(x)+g(y)}{2} \end{aligned}$$

Thus

$$g\left(\frac{x+y}{2}\right) = \frac{g(x)+g(y)}{2} \text{ for all } x, y \text{ in } [a, b]$$

Using Theorem 2.6, we deduce that for all  $x$  in  $[a, b]$

$$g(x) = \alpha x + \beta \quad \alpha, \beta \in \mathbb{R}$$

Then  $g$ , which is defined on all of  $\mathbb{R}$  is also determined on  $[2a, 2b]$  via the conditional Cauchy equation.

If  $[2a, 2b] \cap [a, b] \neq \emptyset$ , we have to check the constants. In this case there exists  $x \in [a, b]$ ,  $y \in [a, b]$  with  $x + y \in [2a, 2b] \cap [a, b]$ . Thus

$$\alpha(x+y) + \beta = \alpha x + \beta + \alpha y + \beta$$

which implies  $\beta = 0$ . That is  $g(x) = \alpha x$ ;  $\forall x \in [a, b] \cup [2a, 2b]$ .

If  $[2a, 2b] \cap [a, b] = \emptyset$ , then  $g(x) = \alpha x + \beta$   $\forall x \in [a, b]$  and  $g(x) = \alpha x + 2\beta$ ;  $\forall x \in [2a, 2b]$ .

Clearly, a solution of the Cauchy equation,  $f(x+y) = f(x) + f(y)$ , or with the addition of a constant  $f(x) + \gamma$ , satisfies the Jensen equation as we have proved that for additive function  $f(\alpha x) = \alpha f(x)$  for every rational  $\alpha$  and so for  $\alpha = \frac{1}{2}$  (Corollary 1.1).



If we look at inequalities, more convenient than the Cauchy inequality dealt with in 1.6, is the inequality as deduced from Jensen equation

$$(4) \quad f\left(\frac{x+y}{2}\right) \leq \frac{f(x)+f(y)}{2}$$

A function  $f: \mathbb{R} \rightarrow \mathbb{R}$ , satisfying (4), is called a Jensen convex function, the properties of which will be studied in Chapter IV, §6.

### 2.5 A generalized Cauchy equation

Let us begin with a result which will lead us afterwards to a conditional Cauchy equation.

Theorem 2.8 Let  $S$  be a semi-group and  $H$  be an inner product space (either real or complex). Suppose  $f: S \rightarrow H$  and suppose  $f$  satisfies

$$(1) \quad \|f(x+y)\| = \|f(x) + f(y)\| \quad \text{for all } x, y \text{ in } S$$

Then  $f: S \rightarrow H$  satisfies  $f(x+y) = f(x) + f(y)$

The main interest of this theorem is that no topology is involved and no regularity assumption is being made on  $f$ .

Proof We shall first prove that  $f(2x) = 2f(x)$  for all  $x$  in  $S$ . We start from the obvious  $\|f(2x)\| = 2\|f(x)\|$  and proceed to estimate  $\|f(3x)\|$

$$(2) \quad \|f(3x)\| = \|f(2x+x)\| = \|f(2x) + f(x)\| \leq \|f(2x)\| + \|f(x)\| \leq 3\|f(x)\|$$

Now,  $f(4x)$  can be estimated in two different ways

$$(3) \quad \|f(4x)\| \leq \|f(3x) + f(x)\| \leq \|f(3x)\| + \|f(x)\| \leq 3\|f(x)\| + \|f(x)\| \leq 4\|f(x)\|$$

and

$$\|f(4x)\| = \|f(2x) + f(2x)\| = 2\|f(2x)\| = 4\|f(x)\|$$

Thus the inequalities in (3) are in fact equalities, which yields

$$\|f(3x)\| = 3\|f(x)\|$$

In the same way, inequalities in (2) are in fact equalities

$$\|f(2x) + f(x)\| = \|f(2x)\| + \|f(x)\|$$

As  $H$  is an inner product space, we have Apollonius' identity (Parallelogram Law), namely

$$\|a+b\|^2 + \|a-b\|^2 = 2(\|a\|^2 + \|b\|^2);$$

Such an identity characterizes inner product spaces (either real or complex) among all normed spaces. (See Chapter VI, §3). With  $a = f(2x)$  and  $b = f(x)$ , and noting that  $\|a\| = 2\|b\|$ , we get

$$(\|f(2x)\| + \|f(x)\|)^2 + \|f(2x) - f(x)\|^2 = 2(\|f(2x)\|^2 + \|f(x)\|^2)$$

which yields

$$\|f(2x) - f(x)\| = \|f(x)\|$$

Applying Apollonius' identity once more with  $a = f(2x) - 2f(x)$  and  $b = f(2x)$  we get

$$2(\|f(2x)\|^2 + \|f(2x) - 2f(x)\|^2) = 4\|f(2x) - f(x)\|^2 + 4\|f(x)\|^2$$

$$8\|f(x)\|^2 + 2\|f(2x) - 2f(x)\|^2 = 8\|f(x)\|^2$$

Thus

$$f(2x) = 2f(x).$$

We shall now prove that for all  $x, y$  in  $S$ , we get

$$(4) \quad \operatorname{Re} \langle f(x), f(x) + f(y) - f(x+y) \rangle = 0$$

We start by computing  $\|f(2x+y)\|$  in two different ways:

$$\|f(2x+y)\| = \|2f(x) + f(y)\| = \|f(x) + (f(x) + f(y))\|$$

and

$$\|f(2x+y)\| = \|f(x) + f(x+y)\|$$

Expanding the following:

$$\|f(x) + f(x+y)\|^2 = \|f(x) + (f(x) + f(y))\|^2$$

yields precisely Eq (4). For reasons of symmetry on  $x$  and  $y$ , we also get

$$\operatorname{Re} \langle f(y), f(x) + f(y) - f(x+y) \rangle = 0$$

Now let us compute  $\|f(x+y)\|^2$  as follows:

$$\begin{aligned} \|f(x+y)\|^2 &= \|f(x) + f(y) + (f(x+y) - f(x) - f(y))\|^2 \\ &= \|f(x) + f(y)\|^2 + \|f(x+y) - f(x) - f(y)\|^2 \\ &\quad + 2\operatorname{Re}\langle f(x), f(x+y) - f(x) - f(y) \rangle \\ &\quad + 2\operatorname{Re}\langle f(y), f(x+y) - f(x) - f(y) \rangle \end{aligned}$$

leading to the desired result  $\|f(x+y) - f(x) - f(y)\|^2 = 0$ , which ends the proof of Theorem 2.8.

From Theorem 2.8, we immediately deduce the following

Corollary 2.1 A function  $f: \mathbb{R} \rightarrow \mathbb{R}$  which satisfies

$$(5) \quad (f(x+y))^2 = (f(x) + f(y))^2$$

in fact satisfies the Cauchy equation.

This time, Eq (5) is equivalent to a conditional Cauchy equation

$$(6) \quad f(x+y) = f(x) + f(y) \quad \text{for all } x, y \text{ such that the following holds:} \\ f(x+y) + f(x) + f(y) \neq 0.$$

It seems then natural to try to generalize Corollary 2.1, with the conditional Cauchy equation (6), in different algebraical structures.

Among others, we shall then prove the following result.

Let  $S$  be a semi-group and  $F$  be an abelian group containing no element of order 3. Then the conditional Equation (6) is equivalent

to the ordinary equation of additivity  $f(x+y) = f(x) + f(y)$  for all  
 $x, y$  in  $S$  when  $f: S \rightarrow F$ .

The conditions for the normed space  $H$  in Theorem 2.8 cannot be weakened too much as the following theorem holds.

Theorem 2.9 Let  $S$  be a semi-group. Suppose there exists  $g: S \rightarrow \mathbb{R}$   
which is not identically zero and satisfies  $g(x+y) = g(x) + g(y)$  for all  
 $x, y$  in  $S$ . Let  $H$  be a not strictly convex normed space. Then there  
exists an  $f: S \rightarrow H$  such that

$$(1) \quad ||f(x+y)|| = ||f(x) + f(y)||$$

but such that  $f$  is not an homomorphism from  $S$  into  $H$ .

Recall that a normed space is strictly convex if  $||x|| = ||y|| = ||\frac{x+y}{2}|| = 1$  implies  $x = y$ . If we suppose that  $H$  is not strictly convex, there exist two elements  $a, b$  in  $H$ , with  $||a|| = ||b|| = 1$  and such that  $a \neq b$  and  $||a+b|| = ||a|| + ||b||$ .

The elements  $a, b$  are linearly independent (If for example  $a = \lambda b$ , then  $|\lambda| = 1$  and  $|\lambda+1| = 2$  so that  $\lambda = 1$  which is impossible). Moreover, when  $\lambda$  and  $\mu$  are of the same sign (both positive or both negative) we get

$$(7) \quad ||\lambda a + \mu b|| = |(\lambda||a|| + \mu||b||)| = |\lambda + \mu|$$

Indeed, if for example  $\mu > \lambda \geq 0$ , we can write

$$||\lambda a + \mu b|| = ||\mu(a+b) - (\mu-\lambda)a|| \geq |\mu||a+b|| - (\mu-\lambda)||a||$$

and thus

$$||\lambda a + \mu b|| \geq \lambda||a|| + \mu||b||$$

The converse inequality being true, we get the required equality (7). Now, using a nontrivial homomorphism  $g: S \rightarrow \mathbb{R}$ , we define a function  $f: S \rightarrow H$  according to

$$f(x) = \begin{cases} g(x)a & \text{if } |g(x)| \leq 1 \\ s(g(x))a + (g(x) - s(g(x)))b & \text{if } |g(x)| > 1 \end{cases}$$

where  $s(g(x)) = +1$  if  $g(x) \geq 0$  and  $s(g(x)) = -1$  if  $g(x) < 0$ . The idea is to have the sum of the coefficients of  $a$  and  $b$  equal to  $g(x)$ , so that using (7) we may expect (1) to hold but not the Cauchy equation. Let us first prove that  $||f(x+y)|| = ||f(x) + f(y)||$ .

We notice that  $||f(x)|| = |g(x)|$  using relation (7).

So  $||f(x+y)|| = |g(x+y)|$ .

Now we compute  $||f(x) + f(y)||$ . We have to make a distinction among four cases according to the relationship of  $|g(x)|$  and  $|g(y)|$  to 1.

If  $|g(x)| \leq 1$  and  $|g(y)| \leq 1$ , then  $f(x) + f(y) = (g(x) + g(y))a = g(x+y)a$

and so  $|g(x+y)| = ||f(x) + f(y)||$ .

If  $|g(x)| \leq 1$  and  $|g(y)| > 1$ , then  $f(x) + f(y) = (g(x) + s(g(y)))a + (g(y) - s(g(y)))b$

and so both coefficients of  $a$  and  $b$  have the same sign. Thus

$$||f(x) + f(y)|| = |g(x) + s(g(y)) + g(y) - s(g(y))| = |g(x+y)|$$

If  $|g(x)| > 1$  and  $|g(y)| \leq 1$ , the same result holds by symmetry.

If  $|g(x)| > 1$  and  $|g(y)| > 1$ , then  $f(x) + f(y) = (s(g(x)) + s(g(y)))a + (g(x+y) - (s(g(x)) + s(g(y))))b$

Either  $s(g(x)) = -s(g(y))$  and then  $||f(x) + f(y)|| = |g(x+y)|$  or both

coefficients have the same sign which also yields  $||f(x) + f(y)|| = |g(x+y)|$ .

So, we have proved  $||f(x) + f(y)|| = ||f(x+y)||$ .

However  $f$  is not an homomorphism. For example, there exists an  $x_0 \in S$  such that  $g(x_0) \neq 0$ , and changing  $g$  into  $-g$  if necessary, we may suppose  $\alpha = g(x_0) > 0$ . For  $n$  large enough,  $g(nx_0) > 1$ . With  $x = nx_0$  and  $y = mx_0$  we get  $g(x) > 1$ ,  $g(y) > 1$  and  $g(x+y) > 1$ . Thus

$$f(x) + f(y) = 2a + (g(x+y) - 2)b$$

and

$$f(x+y) = a + (g(x+y) - 1)b$$

Finally

$$||f(x) + f(y) - f(x+y)|| = ||a-b|| \neq 0.$$

The problem of determining those normed spaces characterized by the equivalence of Eq (1) and the equation of additivity, even in the case of  $S$  being some group like the additive  $\mathbb{R}$ , remains open.

However, if we assume some mild regularity on  $f$ , defined over all of  $\mathbb{R}$ , then we may obtain a characterization of strictly convex normed spaces.

Theorem 2.10 Let  $H$  be a normed space (real or complex) and consider the class  $B$  of all  $f: \mathbb{R} \rightarrow H$  such that there exists a subset  $E$  of  $\mathbb{R}$ , of positive Lebesgue measure and a Lebesgue measurable function  $h: E \rightarrow \mathbb{R}$  with  $||f(x)|| \leq h(x)$ .

Then  $H$  is strictly convex if and only if the only functions  $f$  in  $B$  such that for every  $x, y$  in  $\mathbb{R}$

$$||f(x+y)|| = ||f(x) + f(y)||$$

are the ones which satisfy the Cauchy equation from  $\mathbb{R}$  into  $H$ .

Proof. If  $H$  is not strictly convex, the counter-example given with Theorem 2.9 could be chosen as an element of  $B$ , using a continuous  $g$ .

If  $H$  is strictly convex, let  $f: \mathbb{R} \rightarrow H$  such that

$$||f(x+y)|| = ||f(x) + f(y)||$$

As in Theorem 2.8, we may deduce that  $f(2x) = 2f(x)$  for all  $x \in \mathbb{R}$ , from the strict convexity of  $H$ . The proof proceeds as follows:

$$||f(2x) + f(x)|| = ||f(2x)|| + ||f(x)||$$

as obtained in general. Also  $||f(2x)|| = 2||f(x)||$ . So we may write

$$||f(2x) + f(x)|| = ||\frac{f(2x)}{2}|| + ||\frac{f(2x)}{2}|| + ||f(x)||$$

and also

$$||f(2x) + f(x)|| \leq ||\frac{f(2x)}{2}|| + ||\frac{f(2x)}{2} + f(x)||$$

Thus

$$||\frac{f(2x)}{2} + f(x)|| = ||\frac{f(2x)}{2}|| + ||f(x)||$$

with  $||\frac{f(2x)}{2}|| = ||f(x)||$ . Strict convexity of  $H$  implies  $\frac{f(2x)}{2} = f(x)$ .

By induction, let us show that  $f(nx) = nf(x)$ . We get

$$\begin{aligned} ||f((n+1)x)|| &= ||f(nx) + f(x)|| \\ &= ||nf(x) + f(x)|| = (n+1)||f(x)|| \end{aligned}$$

But

$$||f((n+2)x)|| = ||f((n+1)x) + f(x)|| \leq ||f((n+1)x)|| + ||f(x)|| = (n+2)||f(x)||$$

As the two extreme terms are equal, we get an equality sign everywhere.

The intermediate equality yields, due to strict convexity

$$f((n+1)x) = (n+1)f(x)$$

This process yields also  $f(rx) = rf(x)$  for every positive rational  $r$ .

To proceed further, we need class B. Define  $g(x) = ||f(x)||$ , so that

$g: \mathbb{R} \rightarrow [0, \infty[$  satisfy

$$g(rx) = rg(x) \quad \text{for every positive rational } r$$

and

$$g(x+y) \leq g(x) + g(y)$$

thus  $g$  is a Jensen convex function (cf §2.4)

$$g\left(\frac{x+y}{2}\right) \leq \frac{g(x)+g(y)}{2}$$

Moreover  $g(x) \leq h(x)$  for all  $x \in E$ . A classical theorem, along the same lines as Theorem 1.2, and proved in Chapter IV (Theorem 4.13)

asserts that such a  $g$  must be continuous on  $\mathbb{R}$ . Therefore, as

$g(rx) = rg(x)$ , we get  $g(x) = g(1)x$  for all  $x \geq 0$  and so

$$||f(x)|| = ||f(1)||x \quad \text{for all } x \geq 0$$

But  $f(0) = 0$  and  $f$  is odd (as  $||f(x) + f(-x)|| = 0$ ), so that  $g$

is even. Therefore

$$||f(x)|| = ||f(1)|| |x| \quad \text{for all } x \in \mathbb{R}$$

Now

$$||f(x+y)|| = ||f(1)|| |x+y|$$

and for  $x, y \geq 0$ , we get

$$||f(x+y)|| = ||f(x) + f(y)|| = ||f(x)|| + ||f(y)||$$

This yields the linear dependence of  $f(x)$  and  $f(y)$  for all  $x, y$  in  $\mathbb{R}^+$  and so in  $\mathbb{R}$ . As  $f(x) \neq 0$  if  $x \neq 0$ , we deduce for  $x \geq 0$  ;

$$f(x) = \lambda(x) f(1) \quad \text{with } \lambda(x) \geq 0. \quad \text{But for } x \geq 0 \quad \lambda(x) = x.$$

Thus  $f(x) = xf(1)$  for all  $x \geq 0$  and so for all  $x \in \mathbb{R}$ . Therefore  $f$  satisfies the Cauchy equation, which ends the proof of Theorem 2.10.

Note Instead of the class B, we may consider a more general class  $\mathcal{D}$  containing B namely the class of all those  $f: \mathbb{R} \rightarrow H$  with  $||f(x)|| \leq M$  for all  $x$  belonging to some subset  $E$  of  $\mathbb{R}$  such that  $Q(E-E)$  contains a subset of positive Lebesgue measure. (See Chapter IV § 3 for the definition of  $Q(E-E)$ ). With  $\mathcal{D}$ , in place of B, Theorem 2.10 remains valid.

## 2.6 A functional equation from information theory

Our aim in this section is only to explain how conditional equations appear in information theory. In starting with this theory, we try to find a way of measuring the amount of information contained in the occurrence of some event  $A$  among other events. The usual mathematical method, since Kolmogoroff in the thirties, for specifying a family of events on which we could work, is to consider a probability space  $(\Omega, F, P)$  where  $\Omega$  is a set,  $F$  a  $\sigma$ -algebra of subsets of  $\Omega$ , the family of random events, and  $P$  a probability defined over  $F$ .

Our measure of information contained in  $A$ ,  $A \in F$ , shall to begin with, only depend upon the probability of the random event  $A$ . In other words, this measure of information can be defined using a function  $f: [0,1] \rightarrow \mathbb{R}$  so that with every  $A$  we associate  $f(P(A))$ . A convenient normalization will be to assign

$$(1) \quad f\left(\frac{1}{2}\right) = 1$$

We notice  $f(P(\Omega)) = f(1)$  and  $f(P(\emptyset)) = f(0)$  so that a second axiom of normalization for  $f$  will be

$$(2) \quad f(0) = f(1)$$

The main hypothesis will now be about the information contained in two mutually exclusive random events  $A$  and  $B$ . Let us temporarily denote by  $I(A, B)$  this measure of information.

On one hand, we shall assign to  $I(A, B)$  the sum of  $f(P(A))$  and the measure of the relative information contained in  $B$  with respect to the complement of  $A$ . Using conditional probability, this amounts to defining

$$I(A, B) = f(P(A)) + P(\bar{A})f\left(\frac{P(B)}{P(\bar{A})}\right)$$

(If  $B$  is of probability zero, we take  $I(A, B) = f(P(A))$ ).

On the other hand, we also prescribe a symmetric relation

$$I(A, B) = I(B, A)$$

Such relations induce a functional equation for the unknown function  $f$ . Let  $x = P(A)$  and  $y = P(B)$ , we deduce that

$$(3) \quad f(x) + (1-x)f\left(\frac{y}{1-x}\right) = f(y) + (1-y)f\left(\frac{x}{1-y}\right)$$

Clearly  $x$  and  $y$  satisfy  $0 \leq x \leq 1$  and  $0 \leq y \leq 1$ . But as  $A$  and  $B$  are mutually exclusive, we must add an inequality which restricts the domain of validity of Eq (3)

$$(4) \quad x + y \leq 1$$

By definition, an information function is a function  $f: [0,1] \rightarrow \mathbb{R}$  satisfying (1), (2) and (3) for all  $x, y$  in the triangle  $Z$  where

$$Z = \{(x, y) \mid 0 \leq x \leq 1; 0 \leq y \leq 1; 0 \leq x + y \leq 1\}.$$

Thus, at the very beginning of an axiomatic treatment of information theory, we come out with a conditional functional equation. It can be proved (cf Bibliography) that an information function is Lebesgue measurable if and only if it is of the form

$$\begin{aligned} -f(x) &= x \log_2 x + (1-x) \log_2 (1-x) & 0 < x < 1 \\ &= 0 & x = 0 \text{ or } x = 1 \end{aligned}$$

Such a function is generally known as the Shannon entropy. In fact the functional equation (3), with the restriction as given by (4) is very close to a conditional Cauchy equation. The following result holds (cf Bibliography).

Theorem 2.10  $f: [0,1] \rightarrow \mathbb{R}$  is an information function if and only if there exists  $g: ]0, \infty[ \rightarrow \mathbb{R}$  and

$$(5) \quad g(xy) = g(x) + g(y) \quad \forall x > 0, \forall y > 0$$

$$(6) \quad g\left(\frac{1}{2}\right) = 1$$

$$(7) \quad f(x) = \begin{cases} xg(x) + (1-x)g(1-x) & 0 < x < 1 \\ 0 & x = 0, x = 1 \end{cases}$$

However  $-\log_2 x$  is not the only solution of (5) and (6) and there exist non-(Lebesgue) measurable solutions (cf Chapter IV).

## CHAPTER III

## Conditional Cauchy Equations

Programme We shall begin with a classification of Conditional Cauchy equations. Five types will be exhibited and the rest of chapter will deal with conditional Cauchy equations of the first type. We shall look at some extension theorems for homomorphisms and we shall end with three applications: one is the Bohr compactification of  $\mathbb{R}$ , a second concerns a Conditional Cauchy equation on a very "thin" set  $Z$  and a third one is the theory of additive functions in number theory.

Let  $G, F$  be two groups and  $f: G \rightarrow F$  be a function. Let  $Z$  be a non-empty subset of the product  $G \times G$ . This set  $Z$  may possibly depend upon  $f$ . We shall say that  $f$  satisfies the conditional Cauchy equation (relative to  $Z$ ) if for all  $(x,y)$  in  $Z$  we get

$$f(x*y) = f(x) * f(y)$$

For the sake of brevity, we shall sometimes say that  $f: G \rightarrow F$  is  $Z$ -multiplicative (or multiplicative if  $Z = G \times G$ ) and even  $Z$ -additive (or additive if  $Z = G \times G$ ) if  $G$  is abelian.

3.1 A classification for conditional Cauchy equations

Definition 3.1. If any solution  $f: G \rightarrow F$  of the conditional Cauchy equation relative to  $Z$  satisfies the Cauchy equation for all  $(x,y)$  in  $G \times G$ , then we say that the condition  $(Z,G,F)$  is redundant.

We investigate mainly two kinds of problems:



First problem. Under what hypotheses is the condition  $(Z, G, F)$  redundant?

The hypotheses may be of algebraic or topological character for  $G$  or  $F$ . It may be about the inverse function  $f^{-1}$  or it may be some mild regularity assumption for  $f$ . All such hypotheses are to ensure that the subset  $Z$  is "large enough". We shall try to avoid regularity assumptions on  $f$ . However, it will appear convenient to use a generalization of Definition 3.1.

Condition  $(Z, G, F)$  is said to be redundant for a class  $E$  of functions  $f: G \rightarrow F$  (or  $E$ -redundant) if any function  $f$ , belonging to  $E$ , and  $Z$ -multiplicative, is in fact multiplicative.

Second problem. Find the general solution of the conditional Cauchy equation relative to  $Z$ , when  $(Z, G, F)$  is not redundant.

To facilitate our study, a classification of Conditional Cauchy equations is useful even if it should not be considered as a definitive one. This classification is based on the geometrical shape of  $Z$  in the product  $G \times G$ . We always suppose  $Z \neq \emptyset$ .

Type I.  $Z$  is a right cylinder:  $Z = G \times Y$  ( $Y \neq \emptyset$ ).

$I_1$ .  $Y$  does not depend upon  $f$ ;

$I_2$ .  $Y$  depends upon  $f$ .

Type II.  $Z$  is a rectangle ( $Z = X \times Y$ ) or a triangle.

$II_1$ .  $Z$  is a square,  $X = Y$  is a subsemigroup;

$II_2$ .  $Z$  is a triangle:  $Z = \{(x, y) \in X \times X: x \cdot y \in X\}$ ;

$II_3$ .  $Z$  is a rectangle ( $\emptyset \neq X \neq G, \emptyset \neq Y \neq G$ ):  $Z = X \times Y$

Type III.  $Z$  is an oblique cylinder.

$III_1$ .  $Z = \{(x, y) \in G \times G: x \cdot y \notin \text{Ker } f\}$ ;

$III_2$ .  $Z = \{(x, y) \in G \times G: x \cdot y \notin X, X \subset G, \emptyset \neq X \neq G\}$ .

$III_3$ .  $Z$  is a "tube".

Type IV.  $Z$  is a generalized cylinder.

$IV_1$ .  $Z = \{(x, y) \in G \times G: f(x) \cdot f(y) \neq 1\}$ ;

$IV_2$ .  $Z = \{(x, y) \in G \times G: f(x \cdot y) \neq 1 \text{ and } f(x) \cdot f(y) \neq 1\}$ .

Type V.  $Z$  belongs to a proper linearly invariant set ideal.

We begin our study of all conditional Cauchy equations with a general and easy lemma.

Lemma 3.1 We define  $Z^* = \{(x, y) \in G \times G: f(xy) = f(x)f(y)\}$ .

Then, if  $(x_0, 1) \in Z^*$  for some  $x_0 \in G$ , the following subset  $G_Z$  of  $G$  is a subgroup:

$$G_Z = \{y \in G: (x, y) \in Z^* \text{ for all } x \text{ in } G\}.$$

Proof. As  $(x_0, 1) \in Z^*$ , we get  $f(x_0) = f(x_0)f(1)$  and so  $f(1) = 1$ . If  $y \in G_Z$ , then  $1 = f(y^{-1}y) = f(y^{-1})f(y)$ , so that  $f(y^{-1}) = (f(y))^{-1}$ . We notice  $f(x) = f(xy^{-1}y) = f(xy^{-1})f(y)$  and so  $f(xy^{-1}) = f(x)f(y^{-1})$  for all  $x$  in  $G$ , which yields  $y^{-1} \in G_Z$ . Finally, if  $y_1, y_2 \in G_Z$ , we get  $y_1y_2 \in G_Z$  as

$$f(xy_1y_2) = f(xy_1)f(y_2) = f(x)f(y_1)f(y_2) = f(x)f(y_1y_2).$$

It must be explained why we prefer to specify that  $F$  and  $G$  are groups. In type II, for instance, we could deal with semi-groups only, but those in fact which are embeddable in groups. Therefore, we prefer to keep within

the realm of groups. There remain many open problems for conditional equations on semi-groups in general and a good exercise would be to first check all the results of the following chapters in the semi-group case, mainly when the semi-group possesses non-trivial idempotents.

### 3.2 Conditional Cauchy equations of type I

The first problem, for type I, is solved using the following result.

Theorem 3.1 Let  $F$  be a group with an element of order greater than 2. Let  $G$  be any group. Then  $(G \times Y, G, F)$  is redundant if and only if the subgroup generated by  $Y$  is  $G$ .

Proof. If the subgroup generated by  $Y$  coincides with  $G$ , then since  $G_Z$  contains  $Y$ ,  $G_Z = G$  follows as a consequence of lemma 3.1; this occurs without the assumption on  $F$ . Conversely, suppose that  $Y$  generates a subgroup  $G_0$  in  $G$  with  $G_0 \neq G$ . Let  $g: G \rightarrow F$  be any homomorphism and let  $\tilde{h}: (G/G_0)_\ell \rightarrow F$  be a mapping such that  $\tilde{h}(\pi(1)) = 1$ .

Here  $(G/G_0)_\ell$  denotes the set of all left cosets of  $G$  relative to  $G_0$ . The canonical surjection  $G \rightarrow (G/G_0)_\ell$  is denoted by  $\pi$ . We define  $h: G \rightarrow F$  according to  $\tilde{h}(\pi(x)) = h(x)$ . In particular, we have  $h(G_0) = 1$ . Let  $f(x)$  be the product  $h(x)g(x)$  for all  $x$  in  $G$ . We get for all  $y \in G_0$  and for all  $x \in G$

$$\begin{aligned} f(xy) &= h(xy)g(x)g(y) = h(x)g(x)g(y) \\ &= h(x)g(x)h(y)g(y) = f(x)f(y) \end{aligned}$$

whence  $f: G \rightarrow F$  is  $Z$ -multiplicative for  $Z = G \times G_0$ .

However, suppose first that there exists an  $x_0 \in G$  such that  $\pi(x_0) \neq \pi(x_0^{-1})$ . We may prescribe  $h(x_0) = c$  where  $c \neq 1$  in  $F$  and  $h(x_0^{-1}) = 1$ . In this manner we get

$$1 = f(x_0 x_0^{-1}) \neq f(x_0)f(x_0^{-1}) = c$$

yielding that  $f: G \rightarrow F$  is not multiplicative.

On the other hand, suppose  $\pi(x) = \pi(x^{-1})$  for all  $x$  in  $G$ . As  $(G/G_0)_\ell$  is not reduced to one point, there exists  $x_0$  with  $\pi(x_0) \neq \pi(1)$ . Then prescribe  $h(x_0^{-1}) = h(x_0) = c$  where  $c^2 \neq 1$  which is possible by our assumption on  $F$ . Take  $g \equiv 1$ . We get

$$1 = f(x_0 x_0^{-1}) \neq c^2$$

which ends the proof of the necessity for Theorem 3.1.

Note 1 If every element of  $F$  is of order at most 2, but if  $F$  has at least two elements, then supposing there exist  $x_0, y_0$  in  $G$ ,  $y_0 \notin G_0$ , which are not conjugate with respect to  $G_0$  and not in the same left coset relative to  $G_0$ , we always may construct  $f: G \rightarrow F$ , such that  $f$  is  $(G \times G_0)$  multiplicative but not multiplicative. We just have to define  $\tilde{h}(\pi(z)) = 1$  for all  $z$  in  $G$ , except for those belonging to  $y_0 G_0$ . We define  $\tilde{h}(\pi(y_0)) = c$  for some  $c$  in  $F$  with  $c \neq 1$ . We can use  $f(x) = h(x)$ . Now  $x_0 y_0 \notin y_0 G_0$  and so  $\pi(x_0 y_0) \neq \pi(y_0)$  as well as  $\pi(x_0) \neq \pi(y_0)$ . Therefore  $f(x_0 y_0) = 1$  as well as  $f(x_0) = 1$ . But  $f(y_0) = c$  so

$$1 = f(x_0 y_0) \neq f(x_0)f(y_0) = 1c = c$$

Note 2 The reason why we avoided general semi-groups for  $F$  and  $G$  can

easily be seen through the following example (due to Mark Tamthai).

Let  $F = G$  be the semi-group  $2$  with two elements  $0, 1$  and  $0.0 = 0.1 = 1.0 = 0$ ;  $1.1 = 1$ . Then an  $f: 2 \rightarrow 2$  which is  $(2 \times [0])$ -multiplicative is in fact multiplicative (as  $f(1.0) = f(1)f(0)$  implies  $f \equiv 0$  or  $f \equiv 1$  or  $f(x) \equiv x$ ). Thus Condition  $(2 \times [0], 2, 2)$  is redundant but clearly the singleton  $[0]$  does not generate  $2$  a semi-group: Theorem 3.1 cannot be extended to semi-groups in general.

The construction we gave to prove Theorem 3.1 immediately leads to the solution of the second problem for conditional Cauchy equations of type I. We choose to prove it in the abelian case only. In order to properly state a result, we need to select arbitrarily a lifting  $\xi: G/G_0 \rightarrow G$ , where  $G_0$  is the subgroup generated by  $Y$  for a  $G$  abelian. By definition, a lifting  $\xi$  relative to  $G_0$  is a mapping  $\xi: G/G_0 \rightarrow G$  such that  $\pi \circ \xi$  is the identity on the group  $G/G_0$ . We denote by  $g$  the restriction of function  $f$  to  $G_0$  in order to get

Theorem 3.2 Let  $Y$  be a nonempty subset of an abelian group  $G$ . Denote by  $G_0$  the subgroup of  $G$  generated by  $Y$ . Suppose  $F$  to be an abelian group. A mapping  $f: G \rightarrow F$  satisfies a conditional Cauchy equation relative to  $G \times Y$  if and only if  $f$  can be written in the form

$$(1) \quad f(x) = g(x - \xi(\pi(x))) + h(\pi(x))$$

where  $h: G/G_0 \rightarrow F$  is a function such that  $h(0) = 0$ ,  $g$  is an additive function  $g: G_0 \rightarrow F$ ,  $\xi$  is a lifting relative to  $G_0$  with  $\xi(0) = 0$  and  $\pi: G \rightarrow G/G_0$  is the canonical epimorphism.

Proof: Let  $f$  satisfy relation (2) with the stated properties.

For  $y \in Y$ ,

$$\begin{aligned} f(x+y) &= g(x+y-\xi(\pi(x))) + h(\pi(x)) && \text{as } \pi(x+y) = \pi(x) \\ &= g(x-\xi(\pi(x))) + h(\pi(x)) + g(y) && \text{as } g \text{ is additive on } G_0 \\ &= f(x) + f(y) && \text{as } g(y) = g(y-\xi(\pi(y))) + h(\pi(y)) \end{aligned}$$

(since  $g(y) = g(y-\xi(0)) + h(0) = g(y) - g(\xi(0)) + h(0)$ , we may suppose that only  $g(\xi(0)) = h(0)$  holds).

Conversely, let  $f: G \rightarrow F$  be a  $(G \times Y)$ -additive function. We suppose both  $F$  and  $G$  to be abelian groups and clearly  $g: G_0 \rightarrow F$  being the restriction of  $f$  to  $G_0$  is additive. Let  $\xi$  be a lifting such that  $\xi(0) = 0$ .

$f(x) = f(x-\xi(\pi(x))) + f(\xi(\pi(x))) = g(x-\xi(\pi(x))) + f(\xi(\pi(x)))$  as  $x - \xi(\pi(x))$  belongs to  $G_0$ . From a set-theoretical point of view  $\xi(G/G_0)$  and  $G/G_0$  are isomorphic. There exists  $h: G/G_0 \rightarrow F$ , which is defined according to

$$h(\tilde{x}) = f(\xi(\tilde{x}))$$

for all  $\tilde{x}$  in  $G/G_0$ . Thus

$$f(x) = g(x-\xi(\pi(x))) + h(\pi(x))$$

As  $\xi(0) = 0$ , we deduce that  $h(0) = f(0) = 0$ , which ends the proof of Theorem 3.2. (If we were to take  $\xi(0) \neq 0$ , we should conclude that  $h(0) = g(\xi(0))$ ).

Note 1 If there exists a lifting  $\xi$  which is a homomorphism, then the abelian  $G$  can be identified with the direct product  $G_0 \oplus (G/G_0)$ . Within this identification we may write any  $x$  in  $G$  in the form  $x' \oplus x''$  where  $x' \in G_0$  and  $x'' \in G/G_0$ . In this case the general

solution  $f: G \rightarrow F$  for type I can be written as  $f(x) = g(x') + h(x'')$  where  $g: G_0 \rightarrow F$  is additive, where  $G_0$  is the subgroup generated by  $Y$  in the abelian group  $G$  and where  $h: G/G_0 \rightarrow F$  is any mapping such that  $h(0) = 0$ .

Note 2 It can be checked that the general solution of a conditional Cauchy equation of type I, in the non abelian case, is of the form

$$f(x) = h(\pi(x))g((\xi(\pi(x)))^{-1}x)$$

where  $\xi$  is a lifting relative to  $(G/G_0)_\ell$ ,  $G_0$  being the subgroup generated in  $G$  by  $Y$ ,  $h: (G/G_0)_\ell \rightarrow F$  a mapping,  $g: G_0 \rightarrow F$  a multiplicative mapping and  $h(\pi(1))g((\xi(\pi(1)))^{-1}) = 1$ .

In order to get a redundant condition of type I, we shall investigate three cases implying that  $Y$  generates the group  $G$ . We only get sufficient conditions.

Corollary 3.1 Let  $G$  be a locally compact and connected topological group, and  $F$  be any group. Define  $Z = G \times Y$  where  $Y$  is a subset of  $G$ . Suppose that  $Y$  has a (strictly) positive Haar measure. Then  $(Z, G, F)$  is redundant. The proof is a simple generalization of lemma 1.1. We may always suppose  $Y$  to have a (strictly) positive and finite Haar measure on  $G$ . Using the convolution  $\chi_Y * \chi_Y$ , we deduce that  $Y + Y$  has a non empty interior. The subgroup generated by such an interior is open. It must also be closed because if  $x$  belongs to the closure of an open subgroup, there exists  $y$  in the subgroup such that  $xy^{-1}$  belongs precisely to the open subgroup; therefore  $x$  also. The connectedness of  $G$  ends the proof.

Note 3 The measure-theoretic condition provided by Corollary 3.1 is not

a necessary condition for the redundancy of condition  $(G \times Y, G, F)$ . A convenient counter-example comes from the Cantor ternary set. Such a set is defined as the set of all  $x$  in  $[0,1]$  which can be written with no 1 in some expansion in base 3. It should be clear from the definition that any number in  $[0,1]$  is the midpoint between two points belonging to the Cantor set. To prove this rigorously, let us write any  $x$  in  $[0,1]$  in an expansion of base 3.

$$x = \sum_{i=1}^{\infty} \frac{x_i}{3^i}$$

where  $x_i = 0, 1$  or  $2$ .

If  $x_i = 0$ , we define  $y_i = z_i = 0$ .

If  $x_i = 1$ , we define  $y_i = 2; z_i = 0$  if  $i$  is even, or  $y_i = 0, z_i = 2$  for odd  $i$ .

If  $x_i = 2$ , we define  $y_i = z_i = 2$ .

Therefore

$$y = \sum_{i=1}^{\infty} \frac{y_i}{3^i} \quad \text{and} \quad z = \sum_{i=1}^{\infty} \frac{z_i}{3^i}$$

Both  $y$  and  $z$  are in the Cantor set and are such that  $x = \frac{y+z}{2}$ .

Therefore, the subgroup generated by the Cantor set is  $\mathbb{R}$ . However the Lebesgue (i.e. Haar) measure of the Cantor set is zero. To prove this, we need another construction of the Cantor set, step by step. Let  $x \in [0,1]$  and  $\sum_{i=1}^{\infty} \frac{x_i}{3^i}$ , where  $x_i = 0, 1$  or  $2$ , is one of its expansions

in base 3. Let  $E_1$  be the subset of all  $x \in [0,1]$  such that at least for one such expansion, we get  $x_1 \neq 1$ . More generally, let  $E_n$  be the subset of all  $x$  in  $E_{n-1}$  such that for at least one expansion of  $x$ , we get  $x_n \neq 1$ . The sets  $E_1, E_2, \dots, E_n, \dots$  are closed subsets of

R. Each of these subsets has a Lebesgue measure equal to  $2/3$  of the measure of the previous one. The Cantor set is the intersection of all such  $E_n$ . Therefore its Lebesgue measure is less than  $(2/3)^n$  for all  $n \geq 1$ , which means it is zero. Another completely different approach for redundancy of type I comes from topological considerations.

Corollary 3.2 Let  $G$  be a connected topological group. Suppose  $G$  to be locally compact or metrizable and complete for some metric generating the topology of  $G$ .

Suppose  $Y$  is a second category Baire subset of  $F$  for which there exists a non-empty open subset  $\theta$  of  $G$  such that  $\theta \cap Y$  is of first Baire category.

Let  $F$  be any group and  $Z = G \times Y$  the conditional set. The condition  $(Z, G, F)$  is redundant. By definition, a first category Baire subset of a topological space is a countable union of subsets  $A_n$  for which  $\bar{A}_n$  has no interior. A second category Baire subset is a subset which is not of Baire first category. We shall say that a topological space  $G$  is complete and metrizable if for some metric generating the topology of  $G$ , this space is complete. A classical result will be needed for the proof of Corollary 3.2.

Baire Theorem 3.3 A non-empty open subset of a regular locally compact space or of a complete metrizable space, is of second Baire category.

Proof It is required to prove that  $\bigcup_{n=1}^{\infty} A_n$  does not cover any non empty open subset of the topological space  $G$  whenever  $\bar{A}_n$  has no interior, for all  $n \geq 1$ . We use  $\theta_n = G \setminus \bar{A}_n$ , which is an open and necessarily dense subset of the given topological space  $G$ . Define  $X = \bigcap_{n=1}^{\infty} \theta_n$ . To prove the result, it suffices to show that  $X$  is dense in  $G$ .

Let  $\theta$  be any non empty open subset of  $G$ . For  $n \geq 1$ , and by induction, we choose  $U_n$ , non empty open subset, for which  $\bar{U}_n$  is compact in  $U_{n-1} \cap \theta_n$ . To begin we set  $U_0 = \theta$ . Our choice at the  $n$ th step is possible as  $G$  is regular, and locally compact and  $U_{n-1} \cap \theta_n \neq \emptyset$  since  $\theta_n$  is dense. Therefore  $U = \bigcap_{n=1}^{\infty} \bar{U}_n$  cannot be empty by a compactness argument. But  $\emptyset \neq U \subset \bar{U}_n \subset U_{n-1} \cap \theta_n \subset \theta \cap \theta_n$ . Thus  $\theta \cap X \neq \emptyset$  which ends the proof of the density of  $X$  in  $G$ . The same proof works mutatis mutandis for a complete metrizable topological space. Instead of a compact  $\bar{U}_n$ , choose  $\bar{U}_n$  to have a diameter less than  $1/n$  and conclude with a completeness argument. To prove Corollary 3.8 now, we start from a second category Baire subset  $Y$  of  $G$ , where  $G$  is a connected topological group which is also either locally compact and abelian or complete and metrizable. Let  $\theta$  be a non-empty subset of  $G$  such that  $\theta \cap Y$  is of first Baire category, as provided by our hypothesis (sometime this property for  $Y$  is called Baire property). Let  $x \in \theta$ ,  $V = \theta - x$ , and  $Z = Y - x$ . Thus  $V$  is a neighbourhood of the origin and for any  $t$  in  $V$  ( $V \neq \emptyset$ ) we define

$$V_t = V \cap (t - V)$$

$V_t$  itself is not empty as  $t \in V_t$  and open. Moreover from  $V_t \cap CZ \subset V \cap CZ = (\theta \cap Y) - x$  and from  $V_t \cap C(t - Z) \subset (t - V) \cap t - CZ = t - (V \cap Z)$ , we deduce that  $V_t \cap CZ$  and  $V_t \cap C(t - Z)$  are of first Baire category. So is the union of the two subsets, i.e.  $V_t \cap C(Z \cup (t - Z))$ . But  $V_t$  itself, as a non-empty open subset of our group  $G$ , is of second Baire category. (It is here that we need the hypotheses made over  $G$ , so that we may apply Baire's Theorem 3.3). Thus  $V_t \cap C(Z \cup (t - Z))$  must be of second

category, which proves that  $Z \cap (t-Z)$  is not empty. Therefore, for every  $t$  in  $V$ , there exists  $y_0 \in Z$  and  $z_0 \in Z$  with

$$y_0 = t - z_0$$

With  $y_0 = -x + y$ ,  $y \in Y$  and  $z_0 = -x + z$ ,  $z \in Y$ , we deduce that

$$r = y + z - 2x$$

which yields:  $Y + Y \supset V + 2x$  and so  $Y + Y$  contains a non-empty open subset of  $G$ . The subgroup thus generated by  $Y$  is  $G$  as in Corollary 3.1, yielding the redundancy of the condition  $(Z, G, F)$ .

Note 4 The condition in Corollary 3.2 is not a necessary condition for the redundancy of  $(G \times Y, G, F)$ . We may again use the Cantor ternary set, which is closed with an empty interior to illustrate this. (For any  $x$  in the Cantor set, we may always find  $y$ , not in the Cantor set, as close as we wish to  $x$ , for example by replacing  $x_i$  by 1 for  $i$  large enough in a ternary decimal expansion of  $x$ ). The Cantor set is thus of first Baire category but generates  $\mathbb{R}$ .  $(\mathbb{R} \times Y, \mathbb{R}, \mathbb{R})$  is a redundant condition.

Note 5 We shall show later that it is not possible to only suppose  $Y$  to be of second Baire category, even in  $\mathbb{R}$ , without assuming the Baire property, for Corollary 3.2 to be valid (cf. Chapter IV §3).

Another way of measuring the size of  $Y$ ; purely algebraically is:  
Corollary 3.3 Let  $G$  be any group and suppose that  $Y \neq \emptyset$  and  $\langle Y \rangle$  is a subgroup. Define  $Z = G \times Y$ . Then  $(Z, G, F)$  is redundant for any group  $F$ .

Proof When  $x \in \langle Y \rangle$  and  $y \in Y$ , then  $x \cdot y \in Y$  and so any  $x$  in  $\langle Y \rangle$  can be written as  $y_1 y_2^{-1}$  where  $y_1, y_2 \in Y$ . This means that  $G_0 = G$  and we conclude this proof via Theorem 3.1.

Some other interesting results are known, using other ways of measuring the width of  $Y$ , so as to ensure that  $Y$  generates the whole group. For example with various "thin" subsets of harmonic analysis (say with Hausdorff measure, for instance). We have no room here to state precisely the results as the necessary introduction of new and more complex techniques would not be in harmony with the elementary aspect of the present notes.

### 3.3 Conditional Cauchy equations of type $I_2$

Theorem 3.1 is of little use when dealing with type  $I_2$ , that is when  $Y$  depends upon  $f$ , the unknown function. However Theorem 3.2 will suffice. We investigate here some special cases, such as:  $\langle Y \rangle = \text{Ker } f$  or  $Y = \text{Im } f$ .

Proposition 3.1 Let  $F, G$  be any group, and  $Z, G \times \langle \text{Ker } f \rangle$ . Then  $(Z, G, F)$  is redundant.

Proof We get  $f(xy) = f(x)f(y)$ , for all  $x, y \in G$  such that  $f(y) \neq 1$ . Due to Corollary 3.3, it is enough to prove that  $\text{Ker } f = \{y \in G: f(y) = 1\}$  is a subgroup. In fact,  $f(1) = 1$  as always when  $Z$  is a right cylinder. Moreover, if  $x \in \text{Ker } f$ , then  $x^{-1} \in \text{Ker } f$  since, otherwise, we would get  $1 = f(xx^{-1}) = f(x)f(x^{-1})$  so that  $f(x^{-1}) = 1$  which is a contradiction. In the same way, suppose  $y_1 \in \text{Ker } f$ ,  $y_2 \in \text{Ker } f$  and  $y_1 y_2 \notin \text{Ker } f$ . We get  $f(y_1^{-1} y_1 y_2) = f(y_1^{-1}) f(y_1 y_2)$  and so  $1 = f(y_1 y_2)$  which yields a contradiction.

Our second case is with  $Y = \text{Im } f$ . Here we have to suppose that  $F$  is a subgroup of  $G$  and, without loss of generality, we suppose that  $G = F$ . The conditional Cauchy equation relative to  $(G \times \text{Im } f, G, G)$  becomes

the following functional equation in the abelian case

$$(2) \quad f(x+f(y)) = f(x) + f^2(y) \quad \text{for all } x, y \in G$$

(Here  $f^2(y)$  means  $f(f(y))$ ).

The following theorem gives the general solution in the abelian case. We

use a lifting  $\xi: G/H \rightarrow G$  i.e. an application  $\xi$  such that

$\pi_H \circ \xi \circ \pi_H = \pi_H$  where  $\pi_H$  is the canonical epimorphism  $\pi_H: G \rightarrow G/H$ .

Theorem 3.4 Let  $f: G \rightarrow G$  be a function on an abelian group  $G$ .  $f$  satisfies Eq (2) if and only if there exists a subgroup  $H$  of  $G$ , an additive  $g: H \rightarrow H$ , a lifting  $\xi: G/H \rightarrow G$ , a mapping  $h: G/H \rightarrow H$  such that  $h(0) = g(\xi(0))$  and

$$(3) \quad f(x) = h(\pi_H(x)) + g(x - \xi(\pi_H(x)))$$

Proof Let  $H$  be the subgroup generated by  $\text{Im}f$ . Using lemma 3.1, we notice that  $f$  satisfies a Cauchy conditional equation relative to  $G \times H$ . With a slight modification on the ranges of  $h$  and  $g$ , we may apply Theorem 3.2.

Conversely an  $f: G \rightarrow G$ , satisfying Eq (3), is a solution of Eq (2) and in fact  $f: G \rightarrow H$ . We now deduce the following redundancy result.

Theorem 3.5 Suppose that  $G$  is an abelian group which possesses a non trivial proper subgroup  $H$  of index different from 2. Let  $Z = G \times \text{Im}f$ . In this case, condition  $(Z, G, G)$  is not redundant.

Proof In (3), with the subgroup  $H$  as provided by the hypothesis, we prescribe  $g \equiv 0$  and  $h(\pi_H(x)) = 0$  for any  $x$  in  $H$ ,  $h(\pi_H(x)) = c$

for any  $x$  not in  $H$ . Here  $c$  is an element different from 0 in  $H$ . Then  $f$  is a solution of Eq (2) (or  $(Z, G, G)$  additive). However,  $f$  cannot be additive as there exists  $x, y$  in  $G$  and not in  $H$  such that  $x + y$  too is in  $G$  but not in  $H$  (because the index of  $H$  is distinct from 2 and 1) and so

$$f(x+y) = h(\pi_H(x+y)) = c \neq f(x) + f(y) = h(\pi_H(x)) + h(\pi_H(y)) = c + c$$

Note We could also suppose that there exists a non trivial subgroup  $H$  in  $G$  and an element  $x$  in  $G/H$  such that  $2x \neq 0$ . In such a case, we take  $c \neq 0$  in  $H$  as previously and  $x$  in  $G$  such that  $-\pi_H(x) \neq \pi_H(x)$ . Prescribe  $g \equiv 0$ ,  $h(\pi_H(x)) = c$ ,  $h(-\pi_H(x)) = 0$ ,  $h(0) = 0$  in (3), and arbitrary elsewhere. The function  $f$ , defined via (3), is  $Z$ -additive with  $Z = G \times \text{Im}f$  but not additive as

$$0 = f(0) = f(x-x) \neq f(x) + f(-x) = c + 0 = c.$$

Theorem 3.5 means that  $\text{Im}f$  is too small a size to imply redundancy for  $(G \times \text{Im}f, G, G)$  in general. Regularity assumptions for  $f$ , like continuity, would change nothing in general. For example, with  $G = \mathbb{R}^2$  (an abelian group for the addition), define

$$f(x, y) = (y^2, 0)$$

Clearly  $f: \mathbb{R}^2 \rightarrow \mathbb{R}^2$  is  $(G \times \text{Im}f)$ -additive, but not additive. However, for the special case where  $G = \mathbb{R}$ , we get

Proposition 3.2 Let  $f: \mathbb{R} \rightarrow \mathbb{R}$  be a continuous function satisfying

$$(4) \quad f(x+f(y)) = f(x) + f^2(y) \quad \text{for all } x, y \in \mathbb{R}$$



Then  $f$  is additive and for some  $\alpha$  in  $\mathbb{R}$ ,  $f(x) = \alpha x$ . The condition  $f(0) = 0$  is a consequence of type  $I_2$ . If  $f$  is constant, we deduce that  $f \equiv 0$ . If  $f$  is not constant, its image has a non-empty interior. Therefore such an image generates  $\mathbb{R}$  as a group and Theorem 3.1 implies the redundancy. To end our discussion of Eq (2), we may find its bounded solutions. The following result is easily obtained.

Proposition 3.3 Let  $f: G \rightarrow G$  be a bounded function on a Hausdorff topological linear space  $G$  over the rationals. Then  $f$  satisfies Eq (2) if and only if there exists a subgroup  $H$  of  $G$  such that  $f: G \rightarrow H$ ,  $f(x+H) = f(x)$  for all  $x$  in  $G$  and  $f(H) = 0$ .

The given conditions are sufficient. To prove the necessity, recall that for  $f$  to be bounded means that for every neighbourhood  $V$  of the origin of  $G$ , there exists an integer  $m$  and  $f(x)$  belongs to  $mV$  for all  $x$  in  $G$ . By induction, the functional equation (2) yields for all positive integers  $n$

$$f(x+nf(y)) = f(x) + nf^2(y)$$

which implies that  $f^2 = 0$ . Thus  $f(x+f(y)) = f(x)$  for all  $x, y$  in  $G$ . We now define  $H$  as the set of periods of  $f$ , that is the set of all  $z$  in  $G$  such that  $f(x+z) = f(x)$  for all  $x$  in  $G$ . Such an  $H$  is a subgroup and  $f(0) = 0$  yields  $f(H) = 0$ .

Examples a) Let  $G = \mathbb{R}$  and for all  $x$  in  $\mathbb{R}$ , let  $f(x)$  be the integral part of  $x$ , (i.e. the greatest integer less than or equal to  $x$ ). We get as a functional equation for  $f$

$$(5) \quad f(x+f(y)) = f(x) + f(y)$$

But  $f^2(y) = f(y)$  for all  $y$  in  $\mathbb{R}$  and so we deduce Eq (2) for  $f$ . We shall later solve Eq (5) in any abelian group (cf Chapter VI §5). To write  $f$  according to (3) is easy by taking  $H =$  identifying  $\mathbb{R}/\mathbb{Z}$  with  $[0,1[$ , at least on a set-theoretic point of view, and letting  $h \equiv 0$ ,  $\xi(\pi_H(x)) = \pi_H(x)$ ,  $g(n) = n$  for all  $n$  in  $\mathbb{Z}$ .

b) Let  $G = \mathbb{R}$  and for all  $x$  in  $\mathbb{R}$  let  $f(x)$  be 0 if  $x$  is a rational number ( $x \in \mathbb{Q}$ ), 1 otherwise. Then  $f(x+f(y)) = f(x)$  and  $f^2(y) = 0$  so that Eq (2) is valid (It is Prop 3.3 with  $H=\mathbb{Q}$ ).

Note The general solution of the non abelian version of Eq (2) on a group

$$f(xf(y)) = f(x)f^2(y)$$

will be

$$f(x) = h(\pi(x))g((\xi(\pi(x)))^{-1}x)$$

where  $\xi$  is a lifting relative to  $(G/H)_\ell$ ,  $H$  being a subgroup of  $G$ ,  $h$  a mapping  $h: (G/H)_\ell \rightarrow H$ ,  $g: H \rightarrow H$  a multiplicative mapping and

$$h(\pi(1)) = g(\xi(\pi(1))).$$

We leave to the reader the task of proving the following theorem where another functional equation analogous to Eq (2) is solved on an abelian group.

Theorem 3.6 Let  $G$  be an abelian group. An  $f: G \rightarrow G$  satisfies the functional equation

$$(6) \quad f(x+y-f(y)) = f(x) + f(y-f(y)) \quad \text{for all } x, y \text{ in } G;$$

if and only if there exists a subgroup  $H$  of  $G$ , two liftings  $\xi$  and  $\zeta$



relative to  $H$  and an additive  $g: H \rightarrow H$  such that  $g(\xi(0)) = \zeta(0)$

and

$$(7) \quad f(x) = \zeta(\pi_H(x)) + g(x - \xi(\pi_H(x)))$$

Corollary 3.4 The only continuous solutions  $f: \mathbb{R} \rightarrow \mathbb{R}$  of Eq (6) are the continuous additive functions.

Corollary 3.5 Let  $G, F$  be abelian groups. Let  $X, Y$  be non empty subsets of  $G$ . Then if  $f: G \rightarrow F$  satisfies for all  $x \in X; y \in Y$  and  $z \in G$

$$(8) \quad f(x) + f(y+z) = f(x+y) + f(z)$$

Then there exists  $t_0$  in  $F, x_0$  in  $X$  and with the notations of Theorem 3.2

$$f(x) = t_0 + h(\pi(x-x_0)) + g(x-x_0-\xi(\pi(x-x_0)))$$

Proof Let  $x_0$  in  $X$  and consider  $j(x) = f(x+x_0) - f(x_0)$ . With  $x = x_0, y \in Y$  and  $z = z + x_0$ , we deduce from the given functional equation that

$$f(y+z+x_0) - f(x_0) = f(x_0+y) - f(x_0) + f(z+x_0) - f(x_0)$$

or

$$j(y+z) = j(y) + j(z) \quad \text{for all } y \text{ on } Y \text{ and } z \text{ in } G$$

We are back to Theorem 3.2.

### 3.4 An application to some extension problems for homomorphisms

We start from a subgroup  $H$  of an abelian group  $G$  and from a given function  $g: H \rightarrow H$ . We are looking for an  $f: G \rightarrow G$  such that for all  $x$  in  $G$  and all  $r$  in  $H$ .

$$(1) \quad f(x+r) - f(x) = g(r) \quad x \in G; r \in H$$

Proposition 3.4 Let  $g: H \rightarrow H$  be a mapping where  $H$  is a subgroup of an abelian group  $G$ . A necessary and sufficient condition for the existence of an  $f: G \rightarrow G$  satisfying Eq (1) is that  $g$  be additive. In such a case the general solution of Eq (1)

$$(1) \quad f(x+r) - f(x) = g(r) \quad \text{for all } x \text{ in } G, \text{ all } r \text{ in } H$$

$$\text{is } (2) \quad f(x) = h(\pi_H(x)) + g(x - \xi(\pi_H(x)))$$

where  $h: G/H \rightarrow G$  is an arbitrary function and  $\xi: G/H \rightarrow G$  is a lifting.

The interest in Proposition 3.4 lies in the fact that for a solution  $f: G \rightarrow G$  of Eq (1),  $F(x) = f(x) - f(0)$  is an extension of  $g$  to all of  $G$ . Before proving Proposition 3.4 we may ask for conditions under which such an extension  $F$  happens to be additive. We state :

Proposition 3.5 Let  $H$  be a divisible subgroup of an abelian group  $G$ .

Let  $g: H \rightarrow H$  be additive. There exists an additive  $f: G \rightarrow H$  satisfying

$$(1) \quad f(x+r) - f(x) = g(r) \quad \text{for all } x \text{ in } G, \text{ all } r \text{ in } H$$

and of the form (2) for some convenient  $h$  and  $\xi$ .

Proof of Proposition 3.4 If a function  $f: G \rightarrow G$  satisfies Eq (1), we may suppose  $f(0) = 0$  without loss of generality. Therefore with  $x = 0$  in Eq (1), we deduce that  $f(r) = g(r)$  for every  $r$  in  $H$ . Now, for  $x, r$  in  $H$

$$g(x+r) - g(x) = g(r)$$

which proves that  $g$  is additive.

Conversely, suppose that  $g: H \rightarrow H$  is an additive function, and consider the following  $f$

$$(2) \quad f(x) = h(\pi_H(x)) + g(x - \xi(\pi_H(x)))$$

where  $\xi: G/H \rightarrow G$  is a given lifting relative to  $H$  and  $h: G/H \rightarrow H$  an arbitrary mapping except that  $h(0) = g(\xi(0))$ . We compute for  $x$  in  $G$  and  $r$  in  $H$

$$\begin{aligned} f(x+r) - f(x) &= h(\pi_H(x)) + g(x - \xi(\pi_H(x))) + g(r) - f(x) \\ &= g(r) \end{aligned}$$

Therefore  $f$  is a particular solution of Eq (1). It should be noticed that  $f$  takes its values in  $H$ . Now, the difference of two solutions of Eq (1) is a function  $f'$  which satisfies for all  $x$  in  $G$  and  $r$  in  $H$

$$f'(x+r) = f'(x)$$

Canonically  $f'$  defines a function from  $G/H$  into  $G$ , i.e. some  $h': G/H \rightarrow G$ . This ends the proof of Proposition 3.4.

Proof of Proposition 3.5 We shall prove in the next chapter (Theorem 4.1) that  $g: H \rightarrow H$ , for a divisible group  $H$  and an additive  $g$ , can be extended into an additive  $f: G \rightarrow H$ . For such an  $f$ , we easily notice that  $f(x+r) - f(x) = f(r) = g(r)$  for all  $x$  in  $G$  and all  $r$  in  $H$ . Therefore let  $\xi: G/H \rightarrow G$  be a given lifting relative to  $H$ . As in Proposition 3.4, there must exist an  $h: G/H \rightarrow H$  for which the additive  $f: G \rightarrow H$  can be written as

$$(2) \quad f(x) = h(\pi_H(x)) + g(x - \xi(\pi_H(x)))$$

If there exists a lifting  $\xi$  which is additive, then  $h$  too has to be additive and  $G$  is being split in a direct sum:  $G/H \oplus H$ .

We may now ask the same question as in Proposition 3.5 under some regularity conditions.

Proposition 3.6 Let  $H$  be a closed subgroup of an abelian topological group  $G$ . Suppose  $g: H \rightarrow H$  is a bicontinuous bijection. Then there exists a continuous  $f: G \rightarrow H$  such that

$$(1) \quad f(x+r) - f(x) = g(r)$$

for all  $x$  in  $G$  and all  $r$  in  $H$  if and only if the two following conditions are fulfilled.

(i)  $g$  is additive

(ii) there exists a continuous lifting relative to  $H$ .

Proof From Proposition 3.4, conditions (i) and (ii) yield a continuous solution of Eq (1). This proves the sufficiency part of Prop. 3.6.

Conversely, let us suppose that there exists a continuous solution  $f: G \rightarrow H$  of Eq (1). Without loss of generality we may add  $f(0) = 0$ . Condition (i) is immediate. As  $g$  is a bijection, for any  $x$  in  $G$ , there exists a unique  $\alpha(x)$  in  $H$  for which

$$f(x) + g(\alpha(x)) = 0$$

Let us see which functional equation  $\alpha: G \rightarrow H$  must satisfy. We notice for any  $r$  in  $H$  and  $x$  in  $G$

$$\begin{aligned} f(x+r) + g(\alpha(x)-r) &= f(x) + g(r) + g(\alpha(x)) - g(r) \\ &= f(x) + g(\alpha(x)) \\ &= 0 \end{aligned}$$

By the uniqueness of  $\alpha(x)$ , we deduce for all  $x$  in  $G$ ,  $r$  in  $H$

$$\alpha(x+r) = \alpha(x) - r$$

Therefore we define  $\xi': G \rightarrow G$  according to

$$\xi'(x) = x + \alpha(x)$$

As  $g$  is bicontinuous, the mapping  $\xi'$  is continuous. Moreover, for any  $r$  in  $H$  and all  $x$  in  $G$

$$\xi'(x+r) = \xi'(x)$$

because of  $\xi'(x+r) = x+r + \alpha(x+r) = x+r + \alpha(x) - r = x + \alpha(x) = \xi'(x)$ .

If we put on  $G/H$  the quotient topology,  $\xi'$  canonically defines a continuous  $\xi: G/H \rightarrow G$ . Let us prove that  $\xi$  is a (continuous) lifting.

$$\pi_H \circ \xi'(x) = \pi_H(x) + \pi_H(\alpha(x)) = \pi_H(x)$$

or

$$\pi_H \circ \xi \circ \pi_H = \pi_H.$$

This ends the proof of Proposition 3.6.

Note Proposition 3.6 is no longer valid if the range of  $f$  is not prescribed to be included in  $H$ . A counter-example is as follows. Use  $G = \mathbb{R}$  and  $H = \mathbb{Z}$ . Use  $g(n) = n$  for any  $n$  in  $\mathbb{Z}$ . There exists no continuous lifting from  $\mathbb{R}/\mathbb{Z}$  into  $\mathbb{R}$ . However, the identity mapping on  $\mathbb{R}$  is clearly a continuous solution of  $f(x+n) - f(x) = n$  for all  $x$  in  $\mathbb{R}$  and all  $n$  in  $\mathbb{Z}$ .

### 3.5 Bohr compactification

The construction to be studied in this section is to be used to show how non singular solutions of Cauchy functional equations arise naturally and play a serious role in some classical problems in analysis.

Some results from functional analysis will be required as well as a result from number theory.

#### 3.5.1 Bohr almost periodic functions

Let  $P$  be the set of all functions  $f: \mathbb{R} \rightarrow \mathbb{C}$  which can be written in the form

$$(1) \quad f(x) = \sum_{h=n_1}^{h=n_2} c_h e^{i\lambda_h x}$$

where  $n_1, n_2$  are integers with  $n_1 < n_2$ ; the  $c_h$ 's are complex numbers and the  $\lambda_h$ 's real numbers.

$P$  is clearly a complex linear space of infinite dimension.

We may define on  $P$  a norm, specifically the uniform norm, according to

$$\|f\| = \sup_{x \in \mathbb{R}} |f(x)|$$

$\|f\|$  is finite for any  $f$  in  $P$  as  $\|f\| \leq \sum_{h=n_1}^{n_2} |c_h|$ ;  $\|f\| = 0$  if and

only if  $f \equiv 0$ , that is  $c_h = 0$  for all  $h$ 's;  $\|\lambda f\| = |\lambda| \|f\|$  for all

$\lambda \in \mathbb{C}$ , all  $f \in P$  and  $\|f+g\| \leq \|f\| + \|g\|$ , for all  $f, g$  in  $P$ .

$P$  is thus a normed space, but not a complete space. In order to deal with a Banach space, we define  $A$  to be the closure of  $P$  in the Banach algebra  $C_b(\mathbb{R})$ , of all bounded and complex-valued continuous functions over  $\mathbb{R}$  equipped with the uniform norm. In other words, an element  $f$  of  $A$  is a function  $f: \mathbb{R} \rightarrow \mathbb{C}$  which is the uniform limit of some sequence

$[f_n]_{n \geq 1}, f_n \in P:$

$$\lim_{n \rightarrow \infty} [\sup_{x \in \mathbb{R}} |f(x) - f_n(x)|] = 0$$

$A$  then appears as a Banach subalgebra of  $C_b(\mathbb{R})$  as  $P$  itself is a subalgebra. An element of  $A$  is usually called a Bohr almost periodic function. Such a function is both continuous and bounded. It is easy to find examples of Bohr almost periodic functions. Every continuous and periodic function  $f: \mathbb{R} \rightarrow \mathbb{C}$ , for any  $\alpha \in \mathbb{R}$ , is a Bohr almost periodic function. This comes from Fejér's Theorem, which asserts that every continuous and periodic  $f: \mathbb{R} \rightarrow \mathbb{C}$ , of period  $T$ , is the uniform limit of (finite) trigonometric polynomials  $f$ , namely

$$f_n(x) = \sum_{h=-n}^{+n} (1 - \frac{|h|}{n}) c_h(f) e^{2i\pi h \frac{x}{T}}$$

where  $c_h(f)$  is the  $h$ -th Fourier coefficient of  $f$

$$(2) \quad c_h(f) = \frac{1}{T} \int_{-T/2}^{+T/2} f(x) e^{-2i\pi h \frac{x}{T}} dx$$

### 3.5.2 Mean of a Bohr almost periodic function

We notice that  $Mf = \lim_{T \rightarrow \infty} \frac{1}{2T} \int_{-T}^{+T} f(x) dx$  exists for any  $f$  in

$P$  since for  $e_\lambda: x \rightarrow \exp(i\lambda x)$ ,  $\lambda \in \mathbb{R}$ ,  $M(e_\lambda) = 0$  if  $\lambda \neq 0$  and  $M(e_0) = 1$  if  $\lambda = 0$ .

Moreover the application  $M: P \rightarrow \mathbb{C}$  is linear, bounded and of norm one as

$$|M(f)| \leq \|f\|$$

If  $[f_n]_{n \geq 1}$  a Cauchy sequence in  $P$ , and so converging towards  $f$  in  $A$ , then  $\frac{1}{2T} \int_{-T}^{+T} f(x) dx$  is the uniform limit for  $T > 0$  of  $\frac{1}{2T} \int_{-T}^{+T} f_n(x) dx$ .

We easily deduce the existence, for all  $f$  in  $A$ , of

$$(3) \quad Mf = \lim_{T \rightarrow \infty} \frac{1}{2T} \int_{-T}^{+T} f(t) dt$$

$Mf$  is called the mean of  $f$ . Such a tool may lead to a generalized harmonic analysis of Bohr almost periodic functions by looking at all  $M(fe_\lambda)$ . This will not be our purpose here. We aim at a global study of  $A$ .

3.5.3 The Bohr group We look for the set  $B$  of all functionals  $\hat{x}$  acting on  $A$

$$\hat{x}: A \rightarrow \mathbb{C}$$

where  $\hat{x}$  is both linear and multiplicative, i.e.

- (a)  $\hat{x}(\lambda f + \mu g) = \lambda \hat{x}(f) + \mu \hat{x}(g)$  for all  $\lambda, \mu \in \mathbb{C}$  and for all  $f, g \in A$
- (b)  $\hat{x}(fg) = \hat{x}(f) \hat{x}(g)$  for all  $f, g \in A$
- (c)  $\hat{x}(e_0) = 1$

An element  $\hat{x}$  of  $B$  is necessarily a bounded functional, of norm precisely one. For the proof, we start from any  $f$  in  $A$  for which

$\|f\| \leq 1$ . Let  $\alpha \in \mathbb{C}$  with  $|\alpha| > 1$ . Then  $e_0 - \frac{f}{\alpha}$  is an element of  $A$ , which is nowhere equal to zero. As  $A$  is a Banach algebra, and as

$\|\frac{f}{\alpha}\| < 1$ , we verify in a classical way that  $(e_0 - \frac{f}{\alpha})^{-1} = e_0 + \frac{f}{\alpha} + \dots + (\frac{f}{\alpha})^n + \dots$  is too an element of  $A$ . Therefore, if  $\hat{x} \in B$

$$1 = \hat{x}(e_0) = \hat{x}(e_0 - \frac{f}{\alpha})\hat{x}((e_0 - \frac{f}{\alpha})^{-1}).$$

We deduce that  $\hat{x}(e_0 - \frac{f}{\alpha}) \neq 0$  which amounts to saying that  $\hat{x}(f) \neq \alpha$  which then proves  $|\hat{x}(f)| \leq 1$ . As  $\hat{x}(e_0) = 1$ , we thus have  $\|\hat{x}\| = 1$ , where the norm is the usual one on the linear space of all bounded linear functionals on  $A$ .  $B$  is not an empty set and moreover, it even contains a copy of the set of all real numbers. To see this, take any  $x$  in  $\mathbb{R}$  and define  $\bar{x}^\wedge$  as  $\bar{x}^\wedge(f) = f(x)$  for all  $f$  in  $A$ . Both (a), (b) and (c) are clearly satisfied. Moreover, the application  $x \rightarrow \bar{x}^\wedge$ , from  $\mathbb{R}$  into  $B$ , is one to one as for  $x_1 \neq x_2$ , there exists a  $\lambda \in \mathbb{R}$  and so  $e_\lambda$ , for which  $e_\lambda(x_1) \neq e_\lambda(x_2)$ , so that  $\bar{x}_1^\wedge \neq \bar{x}_2^\wedge$ . However, there are more elements in  $B$  than just those induced from the elements of  $\mathbb{R}$ . To see this, we shall characterize  $B$ . Let  $x^\wedge \in B$  and consider the action of  $x^\wedge$  over all  $e_\lambda$  for  $\lambda \in \mathbb{R}$ ; introducing  $\chi$ .

$$\chi(\lambda) = \langle e_\lambda, x^\wedge \rangle$$

Using  $e_\lambda \cdot e_\mu = e_{\lambda+\mu}$ , we deduce for  $\chi: \mathbb{R} \rightarrow \mathbb{C}$

$$(4) \quad \chi(\lambda+\mu) = \chi(\lambda)\chi(\mu)$$

and

$$(5) \quad |\chi(\lambda)| = 1$$

In particular  $\chi(0) = 1$ .

Conversely, let  $\chi: \mathbb{R} \rightarrow \mathbb{C}$  satisfy both (4) and (5). We define  $x^\wedge$  on the space  $P$  according to

$$x^\wedge(f) = \sum_{h=n_1}^{h=n_2} c_h \chi(\lambda_h) \quad \text{where} \quad f = \sum_{h=n_1}^{h=n_2} c_h e_{\lambda_h}$$

Clearly  $x^\wedge$  is a well defined linear functional on  $P$ . We notice a multiplicative property

$$x^\wedge(fe_\lambda) = \sum_{h=n_1}^{h=n_2} c_h \chi(\lambda_h + \lambda) = \left( \sum_{h=n_1}^{h=n_2} c_h \chi(\lambda_h) \right) \chi(\lambda) = x^\wedge(f)x^\wedge(e)$$

By linearity on  $P$ , we deduce that for all  $f, g$  in  $P$

$$x^\wedge(fg) = x^\wedge(f)x^\wedge(g)$$

If we can prove that  $x^\wedge$  is a bounded linear functional over  $P$ , then we can extend it to a complex linear functional over  $A$  satisfying (a), (b) and (c). To show that  $x^\wedge$  is bounded, we make use of a result from number theory.

Theorem 3.7 Let  $z_1, z_2, \dots, z_n$  be  $n$  complex numbers of modulus one.

Let  $\epsilon > 0$ . Let  $\lambda_1, \lambda_2, \dots, \lambda_n$  be  $n$  real and distinct values. Suppose that for any relation  $\sum_{h=1}^n d_h \lambda_h = 0$ , with integers  $d_h$ , we get the equation

$$\prod_{h=1}^n z_h^{d_h} = 1. \quad \text{Then there exists at least some real number } x \text{ such that}$$

$|e_{\lambda_h}(x) - z_h| \leq \epsilon$  for all  $h = 1, 2, \dots, n$ . Such a theorem is a classical one in the theory of Diophantine approximation (see bibliography).

Now let  $x^\wedge(f) = \sum_{h=n_1}^{n_2} c_h \chi(\lambda_h)$  for  $f = \sum_{h=n_1}^{n_2} c_h e_{\lambda_h}$ . We apply Theorem 3.7 to

$z_h = \chi(\lambda_h)$  and  $\lambda_h$ . We notice that  $\sum_{h=n_1}^{n_2} \alpha_h \lambda_h = 0$  implies that

$$\prod_{h=n_1}^{n_2} (\chi(\lambda_h))^{\alpha_h} = \prod_{h=n_1}^{n_2} z_h^{\alpha_h} = \chi(0) = 1. \quad \text{Therefore, for any } \epsilon > 0, \text{ we can}$$

find  $x \in \mathbb{R}$  such that  $|e_{\lambda_h}(x) - \chi(\lambda_h)| \leq \epsilon$ .

In other words

$$|x^\wedge(f)| \leq \left( \sum_{h=n_1}^{n_2} |c_h| \right) \varepsilon + \left| \sum_{h=n_1}^{n_2} c_h e_{\lambda_h}(x) \right|$$

or

$$|x^\wedge(f)| \leq \varepsilon \left( \sum_{h=n_1}^{n_2} |c_h| \right) + \|f\|$$

As  $\varepsilon$  is arbitrary, we deduce that  $\|x^\wedge\| \leq 1$  and in fact that  $\|\hat{x}\| = 1$  and  $x^\wedge(e_0) = 1$ . We thus have obtained a characterization of  $B$ .

A linear and complex valued functional  $\hat{x}$  on  $A$  belong to  $B$  (i.e. satisfies (a), (b) and (c)) if and only if  $\chi$  satisfies (4) and (5) where  $\chi(\lambda) = \langle e_\lambda, \hat{x} \rangle$  for all  $\lambda$  in  $\mathbb{R}$ .

If now  $\hat{x}$  is an element of  $B$ , deduced from an element  $x$  of  $\mathbb{R}$ , we notice that  $\chi$  is continuous over  $\mathbb{R}$  as  $\chi(\lambda) = \langle e_\lambda, \hat{x} \rangle = e^{i\lambda x}$ . But there too exist non continuous solutions of both Eq (4) and (5) (see Chapter IV, §3) and those non continuous solutions still lead to an element of  $B$ .

Now we shall prove that  $B$  can be equipped with an additive  $*$  for which  $B$  is an abelian group and  $*$  restricted to the injected image of  $\mathbb{R}$  in  $B$  amounts to a copy of the ordinary additive operation on  $\mathbb{R}$ . Let  $\hat{x}_1$  and  $\hat{x}_2$  in  $B$ , we define  $\hat{x}_1 * \hat{x}_2$  according to

$$\langle e_\lambda, \hat{x}_1 * \hat{x}_2 \rangle = \langle e_\lambda, \hat{x}_1 \rangle \langle e_\lambda, \hat{x}_2 \rangle$$

Clearly  $\lambda \rightarrow \langle e_\lambda, \hat{x}_1 * \hat{x}_2 \rangle$  satisfies both (4) and (5), thus leading to an element  $\hat{x}_1 * \hat{x}_2$  in  $B$ . We notice that  $*$  is an associative and

commutative law in  $B$ . Moreover, if  $\hat{x}$  is in  $B$  and  $\hat{0}$  is the element coming from  $x = 0$  in  $\mathbb{R}$ , we get  $\hat{x} * \hat{0} = \hat{0} * \hat{x} = \hat{x}$  as  $\langle e_\lambda, \hat{0} \rangle = 1$  for all  $\lambda$ . In the same way for any  $\hat{x}$  in  $B$ , the mapping  $\lambda \rightarrow \overline{\langle e_\lambda, \hat{x} \rangle}$  gives rise to an element  $\hat{x}_1$  in  $B$  such that  $\hat{x}_1 * \hat{x} = \hat{x} * \hat{x}_1 = \hat{0}$ . Clearly  $(B, *)$  is an abelian group. Moreover, if  $x$  and  $y$  are in  $\mathbb{R}$ , then  $\overline{\hat{x}} * \overline{\hat{y}} = \overline{(\overline{x+y})^\wedge}$  and so  $*$  extends  $+$  to all of  $B$ .

$(B, *)$  is called the Bohr group of  $\mathbb{R}$ . To generalize the process we have developed to go from  $\mathbb{R}$  to  $B$ , we define a character of an abelian topological group  $G$  to be a function  $\chi: G \rightarrow \mathbb{C}$  such that both (4) and (5) are true for all  $\lambda, \mu$  in  $G$ . We have seen how non-continuous characters of  $\mathbb{R}$ , elements of the Bohr group, can be used.

Some topology is needed here.  $B$  is included in the unit ball of the topological dual  $A^*$  of  $A$ . Therefore, as the unit ball is Hausdorff compact in the weak star topology (Alaoglu-Bourbaki Theorem, see bibliography) and as  $B$  is a weak-star closed subset of the unit ball, we conclude that  $B$  is equipped with a Hausdorff compact topology.

It can even be proved (Gelfand's theorem, see bibliography) that  $A$  is isomorphically isometric to  $C(B)$ , the Banach algebra of all continuous and complex-valued functions over the compact  $B$ , equipped with the uniform norm: the mapping being  $f \rightarrow f^\wedge$  where  $f \in A$  and  $\hat{f} \in C(B)$  according to  $f^\wedge(x^\wedge) = (f, x^\wedge)$ .

A simple verification shows that the Bohr group of  $\mathbb{R}$  is a compact topological (abelian) group. With the topology involved, the mapping  $x \rightarrow \hat{x}$  is a continuous, one-to-one mapping, from  $\mathbb{R}$  into its compact Bohr group  $B$ . The image of such a mapping is dense in  $B$  as can

be proved without difficulty. However the mapping is not bicontinuous. Another way to look at the compact topology on  $B$  is to notice that a net  $x_\alpha^\wedge$  in  $B$  converges to  $\hat{x}$  if and only if for all  $\lambda$  in  $\mathbb{R}$ ,  $(e_\lambda, x_\alpha^\wedge)$  converges towards  $(e_\lambda, x)$ .

Any  $f$  in  $A$  can be extended to all of  $B$  as a continuous complex-valued function. As a consequence, if  $\phi: C \rightarrow C$  is a continuous function, then  $\phi \circ f \in A$  for any  $f$  in  $A$ .

Let  $f \in A$ . Consider the set  $[\tau_x(f)]$  of all translates of  $f$  for  $x \in \mathbb{R}$  (with  $\tau_x(f)(y) = f(y-x)$ ). This subset of functions is relatively compact in the uniform norm, as is easy to show using the Bohr group and the Banach algebra  $C(B)$ . Such a result can be proved to be a characterization of almost periodic Bohr functions.

The mean  $M(f)$  of an almost periodic function is translation invariant. It yields a linear form on  $C(B)$  which is also translation invariant. Such a linear form defines the normalized Haar measure of the compact Bohr group  $B$ .

In any locally compact abelian group  $G$ , the set of all continuous characters can be equipped with an addition just by multiplying two characters. Such a set is a group and classically called the dual group  $G^\wedge$  of  $G$ . There exists some topology on  $G^\wedge$  for which  $G^\wedge$  is too a locally compact abelian group. A deep rooted theorem of Pontryagin asserts that  $(G^\wedge)^\wedge$  is isomorphic, as a topological group, to  $G$ .

What we have done then, was to start with  $\mathbb{R}$ , but equipped with the discrete topology, so that we may consider all characters and not

only the continuous ones for the usual topology on  $\mathbb{R}$ . This is still a locally compact group, the dual group of which is precisely the Bohr group, which is compact as the original group is discrete. Consequently  $\mathbb{R}^\wedge$  is the set of all real numbers.

If we were to start with  $\mathbb{R}$ , with the usual topology, we would get  $\mathbb{R}^\wedge = \mathbb{R}$  as its dual group.



### 3.6 Another conditional Cauchy equation on a "thin" set.

Up to now, we have been dealing with rather "large" sets  $Z$ . With some additional regularity assumption over  $f$ , we may proceed to far smaller  $Z$ . A typical result can be obtained in the plane by using for  $Z$  some curve.

Let  $g: \mathbb{R} \rightarrow \mathbb{R}$  and  $h: \mathbb{R} \rightarrow \mathbb{R}$  be two continuous functions such that  $h(0) = g(0) = 0$ ,  $h$  and  $g$  are not zero and have the same sign at any other point of  $\mathbb{R}$  and  $h + g$  is a bijection from  $\mathbb{R}$  onto  $\mathbb{R}$ . For  $Z$ , we take the curve  $C_{g,h}$  defined using  $g$  and  $h$ , that is

$$C_{g,h} = \{(g(x), h(x)); x \in \mathbb{R}\}.$$

Theorem 3.8 Under the previous hypothesis for  $g, h, (C_{g,h}, \mathbb{R}, \mathbb{R})$  is a redundant condition for the class of all functions which are differentiable at 0.

Proof The functional equation of a conditional Cauchy equation relative to  $C_{g,h}$ , can be written as

$$(1) \quad f(g(x) + h(x)) = f(g(x)) + f(h(x)) \quad \text{for all } x \text{ in } \mathbb{R}.$$

Using  $F(x) = g(x) + h(x)$  where  $F: \mathbb{R} \rightarrow \mathbb{R}$  is a bijection and  $y = F(x)$ , Eq (1) is transformed into

$$(2) \quad f(y) = f(g(F^{-1}(y))) + f(y - g(F^{-1}(y))) \quad \text{for all } y \text{ in } \mathbb{R}.$$

It is nicer to transform (2) into a functional equation with some convex appearance. We define  $H(y) = g(F^{-1}(y))$  and  $G(y) = \frac{f(y)}{y}$  for  $y \neq 0$ , but  $G(0) = f'(0)$  (The derivative of  $f$  at 0, which existence is assumed in Theorem 3.8). Eq (2) becomes, at least for  $y \neq 0$  and  $y \neq H(y)$ , through the introduction of  $\alpha(y) = \frac{H(y)}{y}$

$$(3) \quad G(y) = \alpha(y) G(H(y)) + (1-\alpha(y)) G(y-H(y))$$

The following consequences should be noticed for  $H$  and  $\alpha$ .

If  $F(z) > 0$ , then from our hypothesis, we get  $0 < g(z) < F(z)$  which yields  $0 < H(y) < y$  for all  $y > 0$ .

In the same way, we deduce  $y < H(y) < 0$  for all  $y < 0$ .

Then  $0 < \alpha(y) < 1$  for  $y \neq 0$ . We may use for  $\alpha(0)$  any number in  $]0,1[$ , so that Eq (3) remains true for all values of  $y$ . (The case  $y = 0$  yields  $H(0) = 0$ , the case  $H(y) = y$  yields  $h(x) = 0$  with  $y = F(x)$  and so  $F(x) = 0$ , which reduces to the first case:  $y = 0$ ). Our choice of  $G(0)$  is such that  $G$  is continuous at 0. (Notice that  $f(0) = 0$ ).

Therefore, Theorem 3.8 appears as a consequence of the following lemma:

Lemma 3.2 Let  $G: \mathbb{R} \rightarrow \mathbb{R}$  be continuous at 0. Let  $\alpha: \mathbb{R} \rightarrow \mathbb{R}$  be such that  $0 \leq \alpha(y) \leq 1$ . Let  $H: \mathbb{R} \rightarrow \mathbb{R}$  be continuous and satisfy

$$\begin{aligned} \text{for } y > 0: & \quad 0 < H(y) < y \\ \text{and for } y < 0: & \quad 0 > H(y) > y \end{aligned}$$

Then if  $G$  satisfies Eq (3),  $G$  is a constant function.

The proof of this lemma is a nice and easy interplay between continuity and the kind of convexity exhibited through Eq (3). Eq (3) precisely shows that  $G(H(y))$  and  $G(y-H(y))$  cannot simultaneously be strictly greater than  $G(y)$  or cannot simultaneously be strictly smaller than  $G(y)$ . Thus, we start from a  $y_0$ , an arbitrarily chosen positive number. We construct a sequence  $[y_n]_{n \geq 0}$  as follows. If  $y_n$  is known,  $y_{n+1}$  is one of the two possible values  $H(y_n)$  and  $y_n - H(y_n)$ ; the choice being made in such a way that  $G(y_{n+1}) \leq G(y_n)$ .



We also construct a sequence  $[y'_n]_{n \geq 0}$  as follows. We start from  $y'_0 = y_0$ . If  $y'_n$  is known,  $y'_{n+1}$  is that one of the two possible values  $H(y'_n)$  or  $y'_n - H(y'_n)$  such that  $G(y'_{n+1}) \geq G(y'_n)$ . The sequence  $[y'_n]_{n \geq 0}$  is non-increasing and bounded below by zero.

$$0 \leq y_{n+1} \leq \text{Max}(H(y_n), y_n - H(y_n)) \leq y_n$$

Similarly we find that  $[y'_n]_{n \geq 0}$  is non-increasing and bounded below.

The sequence  $[y_n]_{n \geq 0}$  then possesses a limit,  $y_\infty$ , which satisfies the following inequalities

$$y_\infty \leq \text{Max}(H(y_\infty), y_\infty - H(y_\infty)) \leq y_\infty$$

using the continuity of  $H$ . This yields either  $y_\infty = 0$  or  $y_\infty = H(y_\infty)$ . But we already noticed that the last case implies  $\lim_{n \rightarrow \infty} y_n = y_\infty = 0$ . The same result applies to the sequence  $[y'_n]_{n \geq 0}$ , so that  $\lim_{n \rightarrow \infty} y'_n = y'_\infty = 0$ . Going back to  $y_n$  and  $y'_n$ , we may write

$$G(y_n) \leq G(y_0) \leq G(y'_n)$$

Thus with the continuity of  $G$  at  $0$ ,  $G(y_0) = \lim_{n \rightarrow \infty} G(y_n) = \lim_{n \rightarrow \infty} G(y'_n) = G(0)$ ,

proving  $G$  is constant, at least on  $\mathbb{R}_+$  as  $y_0$  was arbitrarily chosen on this set. But the same argument works for  $y_0 < 0$ , using an inequality of the form  $y_n \leq \text{Min}(H(y_n), y_n - H(y_n)) \leq y_{n+1} < 0$ . This ends the proof of the lemma 3.2.

Example  $f(x) = ax$  (a arbitrary) is the only solution, which is differentiable at  $0$ , for the functional equation

$$(4) \quad f(2x) = f(x + \sin x) + f(x - \sin x)$$

Corollary 3.6 Let  $Z$  be the graph of a strictly increasing continuous function  $h: \mathbb{R} \rightarrow \mathbb{R}$  with  $h(0) = 0$ . The condition  $(Z, \mathbb{R}, \mathbb{R})$  is redundant for the class of all functions differentiable at  $0$ .

Otherwise stated, when  $f'(0)$  exists, the only solution  $f: \mathbb{R} \rightarrow \mathbb{R}$  of

$$(5) \quad f(x+h(x)) = f(x) + f(h(x))$$

are the regular ones ( $f(x) = ax$  for some  $a$  in  $\mathbb{R}$ ) when  $h: \mathbb{R} \rightarrow \mathbb{R}$  is a strictly increasing and continuous function, zero at the origin. (With  $g(x) = x$ , conditions for Theorem 3.8 are fulfilled as  $x + h(x)$  is a continuous bijection from  $\mathbb{R}$  onto  $\mathbb{R}$ ,  $\lim_{x \rightarrow -\infty} (x+h(x)) = -\infty$  and

$\lim_{x \rightarrow +\infty} (x+h(x)) = +\infty$ ,  $x + h(x)$  is strictly increasing, continuous and

$h(0) = 0$ ). Curves like  $C_{g,h}$  are not very oscillatory and we should like to obtain at least the regular solutions of Eq (5) for rather general continuous  $h$ , and not only for the continuous and strictly increasing ones. Let us define the cone  $C_1 = [(x,y); x = y = 0 \text{ and } 0 < y < -x \text{ and } 0 > y > -x]$  in the plane

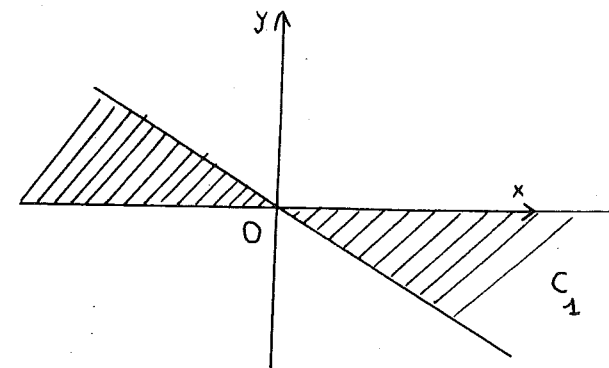

Theorem 3.9 If  $Z$  is the graph of a continuous  $h: \mathbb{R} \rightarrow \mathbb{R}$  with  $h(0) = 0$  and if  $Z$  is included in the cone  $C_1$ , then  $(Z, \mathbb{R}, \mathbb{R})$  is redundant for the class of odd functions having a derivative at 0.

With  $H(x) = -h(x)$ , we may write Eq (5) as

$$\begin{aligned} f(x) &= f(x-H(x)) - f(-H(x)) \\ &= f(x-H(x)) + f(H(x)) \end{aligned}$$

In the same way, as with Theorem 3.8, under the same kind of conditions, we can reduce such an equation to Eq (3), using our hypothesis concerning the inclusion of  $Z$  in  $C_1$ . Lemma 3.2 yields the conclusion. Clearly, the curve  $C_1$  can be replaced by its reflection through the line  $y = x$  without changing the conclusion of Theorem 3.9. It should be interesting to find a possible generalization of Theorem 3.9 in the case  $\mathbb{R}^2$  for example and we have tried to state theorem 3.8 or theorem 3.9 using as little as possible from the particular case  $\mathbb{R}$ . The existence of a derivative at 0 for  $f$  is essential for the validity of Theorem 3.8 or 3.9. If we just request that  $f$  be continuous, then the general solution of an equation like (1) or (5) depends upon an arbitrary (continuous) function and  $(Z, \mathbb{R}, \mathbb{R})$  is no longer redundant for the class of continuous functions. This can be shown through a very simple example where  $h(x) = x$  in Eq (5).

$$(6) \quad f(2x) = 2f(x) \quad x \in \mathbb{R}$$

Let  $\phi$  be a continuous real valued function on  $[\frac{1}{2}, 1]$  such that  $2\phi(\frac{1}{2}) = \phi(1)$ .

We define

$$f(x) = \phi(x) \quad \text{for } x \in ]\frac{1}{2}, 1]$$

and

$$f(x) = 2^n \phi\left(\frac{x}{2^n}\right) \quad \text{for } x \in ]2^{n-1}, 2^n], n \in \mathbb{Z}$$

and  $f(0) = 0$ . The function  $f$  as constructed above is continuous on  $[0, \infty[$  and satisfies Eq (6) there. For example at point  $x = 1$  we get

$$\lim_{\substack{x \rightarrow 1 \\ x < 1}} f(x) = \phi(1) = \lim_{\substack{x \rightarrow 1 \\ x > 1}} f(x) = \lim_{\substack{x \rightarrow 1 \\ x > 1}} 2\phi\left(\frac{x}{2}\right) = \lim_{\substack{x \rightarrow \frac{1}{2} \\ x > \frac{1}{2}}} 2\phi(x) = 2\phi\left(\frac{1}{2}\right);$$

$$x = 0, \quad \lim_{x \rightarrow 0} f(x) = \lim_{n \rightarrow -\infty} 2^n \phi\left(\frac{x}{2^n}\right) = 0 = f(0) \text{ as } \phi \text{ is bounded on } ]\frac{1}{2}, 1].$$

With the help of another  $\psi$  on  $[-1, -\frac{1}{2}[$ , we may construct a continuous solution of (6) depending upon almost arbitrarily chosen  $\phi$  and  $\psi$ . (However if we require  $f$  to be differentiable at 0, it is easy to see or a consequence of Theorem 3.8, that both  $\psi$  and  $\phi$  must be of the form  $ax$  for some  $a$  in  $\mathbb{R}$ ). It is still an open problem to solve Eq (5), with just a continuity assumption, when  $h$  is precisely the unknown function  $f$ , viz:

$$(7) \quad f(x+f(x)) = f(x) + f(f(x))$$

There are solutions of the form  $x \rightarrow \text{Sup}(0, \alpha x)$  or  $x \rightarrow \text{Inf}(0, \alpha x)$ . More generally all continuous idempotent ( $f^{(2)} = f$ ) solutions of Eq (7) are known (cf Chapter VI) since in this case it amounts to solving

$$(8) \quad f(x+f(x)) = 2f(x)$$

To end this section, we just notice that Lemma 3.2 provides the following characterization of the exponential function.

Theorem 3.10 Let  $g, h$  be two continuous functions satisfying the same conditions as in Theorem 3.8. Suppose  $f: \mathbb{R} \rightarrow \mathbb{R}$  is differentiable at 0 and  $f(0)$  is strictly positive. If  $f$  satisfies

$$(9) \quad f(g(x) + h(x)) = f(g(x)) f(h(x))$$

for all  $x$  in  $\mathbb{R}$ , then there exists an  $a \in \mathbb{R}$  such that

$$f(x) = \exp(ax)$$

## 3.7 Additive functions in number theory

In this section, we intend to play with two different binary laws, for simplicity addition and multiplication on the set of real numbers.

Arithmeticians for example, have for a long time considered functions

$f: \mathbb{N} \rightarrow \mathbb{R}$  ( $\mathbb{N} = 1, 2, \dots$ ) such that for all relatively prime numbers  $m, n$  in  $\mathbb{N}$  we get

$$(1) \quad f(mn) = f(m) + f(n) \quad (m, n) = 1$$

A classical example is the Euler function which associates with any integer  $n$  the number of its prime divisors. In particular, the Euler function is equal to 1 on any prime number. More generally, let the values of a function  $f: \mathbb{N} \rightarrow \mathbb{R}$  be arbitrarily given on the subset of all prime numbers. We use the unique representation of an arbitrary positive integer  $n$  as a product of powers of prime numbers

$$n = p_1^{h_1} \dots p_m^{h_m}$$

to define  $f$  everywhere on  $\mathbb{N}$ :

$$f(n) = h_1 f(p_1) + \dots + h_m f(p_m)$$

Then  $f: \mathbb{N} \rightarrow \mathbb{R}$  clearly satisfies Eq (1) and in fact satisfies more:

$$(2) \quad f(mn) = f(m) + f(n) \quad \text{for all } m, n \text{ in } \mathbb{N}.$$

The example of the Euler function shows that Eq (2) has fewer solutions than Eq (1). The set of all solutions of Eq (2) for  $f: \mathbb{N} \rightarrow \mathbb{R}$  coincides with the set of all real-valued functions defined on the subset of all prime numbers (In Chapter IV, we shall replace the subset of all prime numbers

by the so-called Hamel basis in order to get the general solution of the Cauchy equation). We shall still restrain the set of solutions by looking at functions  $f: ]1, \infty[ \rightarrow \mathbb{R}$  such that

$$(3) \quad f(xn) = f(x) + f(n) \quad \text{for all } x \text{ in } ]1, \infty[ \text{ and all } n \text{ in } \mathbb{N}.$$

Eq (3) amounts to a conditional Cauchy equation with  $G = \mathbb{R}_*^+ = ]0, \infty[$  an abelian group for multiplication and  $F = \mathbb{R}$ , the usual abelian group for addition.

Indeed, Eq (3) can be interpreted as a conditional Cauchy equation of type I.

To see this, we extend  $f$  to  $]0, \infty[$  according to

$$F(x) = f(nx) - f(n) \quad \text{for some integer } n \text{ such that } nx \geq 1$$

To see that the definition of  $F$  makes sense, we notice that if  $nx \geq 1$  and  $mx \geq 1$ , then

$$f(nx) + f(m) = f(mx) + f(n) = f(nmx)$$

Moreover, as  $f(1) = 0$ ,  $F(x) = f(x)$  for all  $x \geq 1$ . But  $F: ]0, \infty[ \rightarrow \mathbb{R}$  satisfies

$$(4) \quad F(xn) = F(x) + F(n) \quad \text{for all } x \text{ in } ]0, \infty[ \text{ and all } n \text{ in } \mathbb{N}.$$

For the proof, suppose  $m$  is an integer such that  $mx \geq 1$ . Then

$$F(x) + F(n) = f(mx) - f(m) + f(n)$$

and

$$F(xn) = f(mnx) - f(m)$$

But  $f(mnx) = f(mx) + f(n)$  by Eq (3).

Eq (3) is of type I. Therefore, lemma 3.1 shows that Eq (4) holds for all  $x$  in  $]0, \infty[$  and all  $n$  in  $Q_+^+$ , the set of strictly positive rational numbers. With the help of Hamel bases and of the general solution of Eq (2), we may show that Eq (4) still has plenty of solutions. Now we shall make a regularity assumption on  $f$  to avoid the existence of so many solutions.

Theorem 3.11 A monotonic function  $f: [1, \infty[ \rightarrow \mathbb{R}$  is a solution of the conditional Cauchy equation

$$(3) \quad f(xn) = f(x) + f(n) \quad \text{for all } x \text{ in } [1, \infty[ \text{ and all } n \text{ in } \mathbb{N}$$

if and only if there exists a real constant  $\alpha$  and

$$(4) \quad f(x) = \alpha \log x \quad \text{for all } x \text{ in } [1, \infty[.$$

The function  $\alpha \log x$  is clearly a monotonic solution of Eq (3). To prove the converse, we may suppose  $f$  to be non decreasing without loss of generality (replace  $f$  with  $-f$ ). We first notice that the extension  $F$  of  $f$ , as previously devised, is monotonic like  $f$ . (If  $0 < x \leq x'$ , there exists  $n$  and  $nx \geq 1$ . Therefore  $F(x) = f(nx) - f(n) \leq f(nx') - f(n) = F(x')$  if  $f$  is nondecreasing). As  $F$  satisfies a conditional Cauchy equation of type I, we apply Theorem 3.2 to get

$$(5) \quad F(x) = g\left(\frac{x}{\xi(\pi(x))}\right) + h(\pi(x))$$

where  $\pi$  is the canonical epimorphism from  $\mathbb{R}_+^+$  onto  $\mathbb{R}_+^+/Q_+^+$ , and where  $\xi: \mathbb{R}_+^+/Q_+^+ \rightarrow \mathbb{R}_+^+$  a lifting relative to  $Q_+^+$ ,  $g: Q_+^+ \rightarrow \mathbb{R}$  a homomorphism ( $g(xy) = g(x) + g(y)$ , for all  $x, y$  in  $Q_+^+$ ) and  $h = \mathbb{R}_+^+/Q_+^+ \rightarrow \mathbb{R}$  some function with  $g(\xi(\pi(1))) = h(\pi(1))$ . Take  $x = \beta y$  where  $\beta$  is a rational number  $0 < \beta \leq 1$ . We notice that  $x \leq y$  implies that  $F(x) \leq F(y)$ . But  $\pi(x) = \pi(y)$ . Therefore

$$g\left(\frac{\beta y}{\xi(\pi(y))}\right) \leq g\left(\frac{y}{\xi(\pi(y))}\right)$$

which yields, as  $g$  is a homomorphism, and for a rational  $\beta$ ,  $0 < \beta \leq 1$

$$g(\beta) \leq 0$$

In the same way  $g(\beta) \geq 0$  for a rational  $\beta \geq 1$ . The function  $g$  being a homomorphism, we deduce that  $g$  is non-decreasing. We extend  $g$  to all of  $\mathbb{R}_+^+$  according to

$$x \in \mathbb{R}_+^+ \text{ but } x \notin Q_+^+ \quad G(x) = \sup_{\substack{y < x \\ y \in Q_+^+}} g(y)$$

If  $x \in \mathbb{R}_+^+$  and  $y \in \mathbb{R}_+^+$ , with a limit argument, we obtain

$$G(xy) = G(x) + G(y)$$

so that  $G(e^x)$  is a non-decreasing additive function from  $\mathbb{R}$  onto  $\mathbb{R}$ . Theorem 1.1 yields  $G(e^x) = \alpha x$  for all  $x \in \mathbb{R}$  and some  $\alpha \geq 0$ . Going back to (5)

$$F(x) = \alpha \log x + (h(\pi(x)) - \alpha \log \xi(\pi(x))) = \alpha \log x + \zeta(\pi(x))$$

Let  $x \neq y$  in  $\mathbb{R}_+^+$ , and consider positive rational numbers  $\gamma, \delta$  such that  $\gamma x > y$  and  $\delta x < y$

$$F(\gamma x) \geq F(y) \text{ yields } \zeta(\pi(x)) - \zeta(\pi(y)) \geq \alpha \log \frac{y}{\gamma x}$$

$$F(\delta x) \leq F(y) \text{ yields } \zeta(\pi(x)) - \zeta(\pi(y)) \leq \alpha \log \frac{y}{\delta x}$$

We may choose a sequence of  $\gamma$ 's such that  $\lim_{\gamma} \frac{y}{\gamma x} = 1$  and a sequence of  $\delta$ 's such that  $\lim_{\delta} \frac{y}{\delta x} = 1$ . We obtain

$$\zeta(\pi(x)) = \zeta(\pi(y))$$

Since  $x$  and  $y$  were arbitrary, we deduce that  $\zeta(\pi(x)) = \zeta(\pi(1))$  for all  $x$  in  $\mathbb{R}_*^+$ . But  $\zeta(\pi(1)) = 0$  by hypothesis. Finally

$$F(x) = \alpha \log x \quad \text{for all } x \text{ in } \mathbb{R}_*^+$$

which ends the proof of Theorem 3.11. Theorem 3.11 has the possibility of being extended at least for monotonic functions. The cylindrical condition  $Z = \mathbb{R}_*^+ \times \mathbb{N}$  can be replaced by a totally discrete square condition  $Z = \mathbb{N} \times \mathbb{N}$  according to

Theorem 3.12 A monotonic function  $f: \mathbb{N} \rightarrow \mathbb{R}$  is a solution of the functional equation

$$(2) \quad f(nm) = f(n) + f(m) \quad \text{for all } n, m \text{ in } \mathbb{N}$$

if and only if there exists a constant  $\alpha$  and  $f(n) = \alpha \log n$  for all  $n$  in  $\mathbb{N}$ .

As previously, there is no loss of generality in supposing  $f$  to be non-decreasing. Let  $p > 1$  be a given integer. We notice by induction that

$$\frac{f(p^h)}{\log p^h} = \frac{hf(p)}{h \log p} = \frac{f(p)}{\log p}$$

$$\text{Therefore } \lim_{n \rightarrow \infty} \frac{f(n)}{\log n} \leq \frac{f(p)}{\log p}$$

We shall prove the opposite inequality and shall only suppose for  $f$

$\lim_{n \rightarrow \infty} (f(n+1) - f(n)) \geq 0$  instead of plain monotonicity. Let  $\varepsilon$  be a given (strictly) positive number. For  $h$  large enough and for all  $n \geq p^h$ , we get

$$f(n+1) - f(n) \geq -\varepsilon$$

We may write  $n = \alpha_0 + \alpha_1 p + \dots + \alpha_m p^m$ ,  $\alpha_m \neq 0$ , where the  $\alpha_i$ 's are integers between 0 and  $(p-1)$ , and shall use Eq (2) to minimize  $f(n)$

$$\begin{aligned} f(n) &\geq -\alpha_0 \varepsilon + f(p(\alpha_1 + \dots + \alpha_m p^{m-1})) \\ &\geq -\alpha_0 \varepsilon + f(p) - \alpha_1 \varepsilon + f(p(\alpha_2 + \dots + \alpha_m p^{m-2})) \\ &\geq -2(p-1)\varepsilon + 2f(p) + f(\alpha_2 + \dots + \alpha_m p^{m-2}) \\ &\geq -(m-h+1)(p-1)\varepsilon + (m-h+1)f(p) + f(\alpha_{m-h+1} + \dots + \alpha_m p^{h-1}) \end{aligned}$$

Therefore

$$\frac{f(n)}{\log n} \geq -\frac{m-h+1}{\log n} (p-1)\varepsilon + \frac{m-h+1}{\log n} f(p) + \frac{f(\alpha_{m-h+1} + \dots + \alpha_m p^{h-1})}{\log n}$$

But  $\log n$  behaves at infinity like  $m \log p + \log \alpha_m$ , i.e.  $\lim_{n \rightarrow \infty} \frac{\log n}{m} = \log p$ .

We deduce that  $\lim_{n \rightarrow \infty} \frac{m-h+1}{\log n} = \frac{1}{\log p}$  and  $\lim_{n \rightarrow \infty} \frac{f(\alpha_{m-h+1} + \dots + \alpha_m p^{h-1})}{\log n} = 0$

by considering the values of  $f$  on all integers less than  $p^h$ . As a consequence

$$\lim_{n \rightarrow \infty} \frac{f(n)}{\log n} \geq -\frac{p-1}{\log p} \varepsilon + \frac{f(p)}{\log p}$$

$\varepsilon$  being arbitrary, we may conclude  $\lim_{n \rightarrow \infty} \frac{f(n)}{\log n} \geq \frac{f(p)}{\log p}$ . The limit exists

and is  $\lim_{n \rightarrow \infty} \frac{f(n)}{\log n} = \alpha = \frac{f(p)}{\log p}$  for all integers  $p > 1$ . In other

words  $f(p) = \alpha \log p$  for all integers  $p \geq 1$  (as  $f(1) = 0$ ) which ends the proof of Theorem 3.12. (Another proof shall be given as a

consequence of Theorem 4.14). In fact, we may replace Eq (2) by Eq (1) in Theorem 3.12 (see bibliography for the proof).

Theorem 3.13. A function  $f: \mathbb{N} \rightarrow \mathbb{R}$  such that  $\lim_{n \rightarrow \infty} (f(n+1) - f(n)) \geq 0$  is a solution of the functional equation:

$$(1) \quad f(mn) = f(m) + f(n) \quad \text{as soon as} \quad (m,n) = 1$$

if and only if there exists some constant  $\alpha$  and  $f(n) = \alpha \log n$  for all  $n \geq 1$ .

## CHAPTER 4

## Conditional Cauchy Equation of Type II

*Programme* In this chapter, we shall investigate conditional Cauchy equations of type II. We shall mainly be confronted with extension problems for additive functions and shall restrict ourselves to the abelian case. We shall deal with the geometry of divisible abelian groups, that is linear spaces over the field of rational numbers. Therefore bases for such spaces, the so-called Hamel bases, will occur. We shall thus obtain the general solution of Cauchy equations and will be able to investigate the converses of those theorems given in Chapter I. The chapter will end with a look at additive functions in number theory and at Jensen convex functions.

4.1 Z is a square; X = Y is a subsemi-group of an abelian group G.

Theorem 4.1 Let G and F be abelian groups and suppose that F is divisible. Let  $f: G \rightarrow F$  satisfy a conditional Cauchy equation relative to  $Z = X \times X$  where X is a subsemi group of G. Then there exists at least one additive function  $g: G \rightarrow F$  such that  $f = g$  on X.

Proof Let us consider all pairs  $(Y, g)$  such that  $Y$  is a subsemi-group of  $G$  and  $g: G \rightarrow F$  is a  $Z$ -additive function on  $Z = Y \times Y$ . We prescribe a partial order on this family of pairs in a natural way:

$$(Y_1, g_1) \leq (Y_2, g_2)$$

if  $Y_1 \subset Y_2$  and  $g_2$  restricted to  $Y_1$  is equal to  $g_1$ . Let us now consider the non empty family  $F$  of all these pairs  $(Y, g)$  which dominate the given pair  $(X, f)$ . This family is partially ordered. Hausdorff's maximality theorem states that every non empty partially ordered set contains a maximal totally ordered subset (See bibliography for Hausdorff's maximality theorem. But it must be added that from an analytic point of view such a theorem has a strong natural fragrance. In fact, it can be deduced from a specific axiom of set theory, the so-called Axiom of Choice, which simply authorizes the choice of an arbitrary element from each member of an infinite family of non empty sets).

So let  $F'$  be a maximal totally ordered subset of the family  $F$ . Define  $Y = \bigcup_{Y' \in F'} Y'$  and  $g: Y \rightarrow F$  according to  $g(y') = g'(y')$  for all  $y' \in Y'$  where  $(Y', g') \in F'$ . Clearly  $g$  is a well-defined  $Z$ -additive function where  $Z = Y \times Y$  and  $Y$  is a subsemi-group of  $G$ . Moreover  $(Y, g)$  is a maximal element of  $F'$  as  $F'$  itself is a maximal totally ordered subset of  $F$ .

To end this proof it is enough to show that  $Y$  coincides with  $G$ . Suppose, by way of contradiction, the existence of an  $x_0$  in  $G \setminus Y$ . Any element of the semi-group  $Y_0$ , generated by  $Y$  and  $x_0$ , will be written in the form  $y + nx_0$  for some  $y$  in  $Y$  and some positive ( $\geq 0$ ) integer  $n$ . We then define  $\tilde{g}$  on  $Y_0$

$$\tilde{g}(y + nx_0) = g(y) + ny_0$$

where  $y_0$  is some element of  $F$  to be carefully chosen later on. However, for this definition of  $\tilde{g}$  to make sense, it is necessary that

whenever (a)  $y_1 + n_1 x_0 = y_2 + n_2 x_0$  it follows that (b)  $g(y_1) + n_1 y_0 = g(y_2) + n_2 y_0$ . But when (a) holds, assuming for instance that  $n_2 > n_1$ , we get  $(n_2 - n_1)x_0 = y_1 - y_2$ . If the set  $\{x_0, 2x_0, \dots, nx_0, \dots\}$  does not intersect  $Y - Y$ , we may choose  $y_0$  freely. If this set intersects  $Y - Y$  only once, then we have to take

$$y_0 = \frac{g(y_1) - g(y_2)}{n_2 - n_1}$$

which is possible as  $F$  is divisible. However, if there are more intersections, we get for example  $nx_0 = y_1 - y_2$  and  $n'x_0 = y_1' - y_2'$  for some  $y_1, y_2, y_1', y_2'$  in  $Y$  and some strictly positive integers  $n$  and  $n'$ . This yields  $n'y_1 - n'y_2 = ny_1' - ny_2'$ . We now make use of the additivity of function  $g$  on  $Y$  to get

$$n'g(y_1) + ng(y_2') = ng(y_1') + n'g(y_2).$$

This yields  $\frac{g(y_1) - g(y_2)}{n} = \frac{g(y_1') - g(y_2')}{n'}$  and we may choose without ambiguity  $y_0$  to be this common value.

It is easy to check that  $(Y_0, \tilde{g})$  strictly dominates  $(Y, g)$  contradicting the maximality of  $(Y, g)$ . Therefore  $Y = G$  and the proof is complete.

Note 1 We cannot omit the divisibility assumption relative to  $F$  in Theorem 4.1 if for instance, we wish the extension  $g$  to keep its values in  $F$ . (Take  $G = F = \mathbb{Z}$  and  $X = 2\mathbb{N}$ , use  $f: X \rightarrow \mathbb{Z}$  where  $f(2h) = h$ ).



Note 2 The use of a Hamel basis (cf this chapter §3) will help us to visualize how to extend the identity  $f: \mathbb{Q} \rightarrow \mathbb{Q}$  into a non-trivial additive  $g: \mathbb{R} \rightarrow \mathbb{Q}$ . Such an additive  $g$  is very irregular. (cf Theorem 1.1).

Note 3 When  $F$  and  $G$  are not abelian groups, there is no general result like Theorem 4.1 but results depending upon the way  $X$  generates  $G$  as a group. We shall therefore restrict ourselves to the abelian case throughout this chapter.

Clearly, any  $f: G \rightarrow F$ , which is a solution of a conditional Cauchy equation relative to  $Z = X \times X$  where  $X$  is a subsemi-group of  $G$ , has a restriction to  $X$  which is an homomorphism from  $X$  into  $F$ . The conditional Cauchy equation tells nothing about the values of  $f$  outside  $X$ . Therefore, when  $\emptyset \neq X \neq G$  and when  $F$  is not reduced to one element only, it is not difficult to check that condition  $(X \times X, G, F)$  is not redundant. Theorem 4.1 proves the possibility of an extension of the restriction of  $f$  to  $X$  into an additive function on  $G$ , taking its values in  $F$ . We could say  $(X \times X, G, F)$  is quasi-redundant (see also Theorem 4.5). It is interesting to state a uniqueness result for such an extension.

Corollary 4.1 Let  $F$  and  $G$  be divisible abelian groups and let  $X$  be a divisible subsemi-group of  $G$ . Take  $Z = X \times X$ . For any  $Z$ -additive  $f: G \rightarrow F$ , there exists a unique additive  $g: G \rightarrow F$ , with  $g = f$  on  $X$ ; if and only if the subgroup generated by  $X$  in  $G$  coincides with  $G$ .

Proof The sufficiency of Corollary 4.1 is evident and does not require either  $F$  or  $G$  to be divisible groups.

For the necessity, let  $Y$  be the subgroup generated by  $X$  in  $G$ . It is also a divisible subgroup of  $G$ . If an element  $x_0$  in  $G$  does not belong to  $Y$ , then from the divisibility of  $Y$ , a construction similar to the one used while proving Theorem 4.1 leads to an arbitrary choice for  $y_0$ , the value of some extension at  $x_0$ . This contradicts the uniqueness of the additive extension to the whole of  $G$  of the restriction of  $f$  to  $X$ .

Note Corollary 4.1 is no longer valid if we do not specify that  $X$  is also divisible. For example, let  $G = \mathbb{Q}$ ,  $F = \mathbb{R}$  and  $X = \mathbb{Z}$ . Clearly  $\mathbb{Z}$  does not generate  $\mathbb{Q}$  as a subgroup. However, any additive function  $\mathbb{Z} \rightarrow \mathbb{R}$  can be extended in a unique fashion into an additive function  $\mathbb{Q} \rightarrow \mathbb{R}$ .

A way of generalizing Theorem 4.1 is to impose some conditions on an extension of an additive function. Such generalization will prove to be crucial in §4. We have to introduce some notations and definitions. For any subset  $Z$  in  $G \times G$ ,  $t(Z)$  is the subset of all  $z = x + y$  where  $(x, y) \in Z$ . Let  $C$  denote some class of functions  $f: G \rightarrow F$ . A condition  $(Z, G, F)$  shall be called  $C$ -quasi-redundant if for any  $Z$ -additive  $f: G \rightarrow F$  belonging to  $C$ , there exists an additive  $g: G \rightarrow F$ ,  $g$  belonging to  $C$  and  $g = f$  in  $t(Z)$ . We omit  $C$  if  $C$  is the class of all functions  $f: G \rightarrow F$ . For a first example we need some tools.

Definition 4.1 Let  $G$  be a divisible abelian group. A subset  $E$  of  $G$  is  $\mathbb{Q}$ -convex if for any  $x, y$  in  $E$ ,  $\alpha x + (1-\alpha)y \in E$  for all  $\alpha$  in  $\mathbb{Q}$  such that  $0 \leq \alpha \leq 1$ .



Definition 4.2 Let  $G$  be a divisible abelian group. A subset  $E$  of  $G$  is  $Q$ -radial at a point  $x_0$  (of  $E$ ) if for any  $x$  in  $G$  there exists an  $\alpha_0$  in  $Q$ ,  $\alpha_0 > 0$ , such that for every  $\alpha \in Q$ ,  $0 \leq \alpha \leq \alpha_0$ ,  $x_0 + \alpha x$  belongs to  $E$ . Clearly an interval in  $\mathbb{R}$ ,  $[a, b]$ ,  $a < b$ , is both a  $Q$ -convex and  $Q$ -radial subset of  $\mathbb{R}$ . ( $Q$ -radial at any point of  $]a, b[$ ). A set like  $[a, b] \cap Q$  is  $Q$ -convex in  $\mathbb{R}$  but is not  $Q$ -radial in  $\mathbb{R}$  at any of its point. We shall see later (Proposition 4.2) that there exist very pathological  $Q$ -radial and  $Q$ -convex subsets of  $\mathbb{R}$ . However, the following extension results hold.

Theorem 4.2 Let  $G$  be a divisible abelian group. Let  $E$  be a  $Q$ -convex subset of  $G$  which is  $Q$ -radial at  $0$ . Let  $C(E)$  be the subset of all  $f: G \rightarrow \mathbb{R}$  such that  $f(x) \leq 1$  for all  $x$  in  $E$ . Let  $H$  be a divisible subgroup of  $G$ . Condition  $(H \times H, G, \mathbb{R})$  is  $C(E)$ -quasi-redundant. A bilateral inequality works as well.

Corollary 4.2 Let  $G, E, H$  and  $f$  be as in Theorem 4.2. Suppose moreover that  $E = -E$ . Then if  $|f(x)| \leq 1$  for all  $x$  in  $H \cap E$ , there exists an additive  $g: G \rightarrow \mathbb{R}$ , extending  $f$  and  $|g(x)| \leq 1$  for all  $x$  in  $E$ .

Corollary 4.2 can be immediately deduced from Theorem 4.2 as the extension  $g$  provided by Theorem 4.2, when  $E$  is symmetric with respect to the origin ( $E = -E$ ), must satisfy both  $g(x) \leq 1$  and  $g(-x) \leq 1$ ; thus  $|g(x)| \leq 1$ .

Proof of Theorem 4.2 The proof begins as in Theorem 4.1 with the family  $F$  of all pairs  $(H', g')$  such that  $H'$  is a divisible subgroup of  $G$ ,  $g': H' \rightarrow \mathbb{R}$  is an additive function and  $g'(x) \leq 1$  for all  $x$  in  $H' \cap E$ .

Such a family  $F$  is not empty ( $(H, f) \in F$ ) and can be partially ordered in the same way as in Theorem 4.1 for the same kind of order:  $(H', g') \leq (H'', g'')$  if  $H' \subset H''$  and  $g''$  restricted to  $H'$  is equal to  $g'$ . Let  $F'$  be a maximal totally ordered subset of  $F$ . Let  $G' = \cup H'$ ; where  $(H', g') \in F'$ , and define  $g: G' \rightarrow \mathbb{R}$  according to  $g(y') = g'(y')$  for all  $y' \in H'$  where  $(H', g') \in F'$ . Clearly  $g$  is an additive function on the divisible subgroup  $G'$ . In the same way,  $g(x) \leq 1$  for all  $x$  in  $G' \cap E$ . Moreover  $(G', g)$  is a maximal element of  $F'$ . To end the proof, it is enough to show that  $G'$  coincides with  $G$ .

By contradiction, suppose there exists an  $x_0 \in G$ , not belonging to  $G'$ . The divisible subgroup  $G_0$  generated by  $G'$  and  $x_0$  is the set of all  $x + \alpha x_0$  where  $x \in G'$  and  $\alpha \in Q$ . We define  $\tilde{g}: G_0 \rightarrow \mathbb{R}$  according to

$$\tilde{g}(x + \alpha x_0) = g(x) + \alpha y_0$$

where  $y_0$  is a real number to be chosen later on. Function  $\tilde{g}$  is well defined, additive on  $G_0$  and it extends  $g$ . If we were able to choose  $y_0$  so that  $\tilde{g}(y) \leq 1$  for all  $y \in G_0 \cap E$ , we should then have a pair  $(G_0, \tilde{g})$ , strictly dominating  $(G', g)$ , which provides the contradiction we are seeking.

The inequality  $\tilde{g}(y) \leq 1$  means:  $y_0 \leq \frac{1-g(x)}{\alpha}$  if  $\alpha > 0$  and  $y_0 \geq \frac{1-g(x)}{\alpha}$  if  $\alpha < 0$ . Therefore we introduce two elements  $A$  and  $B$  (and shall have to prove they are (finite) real numbers):  $A = \text{Inf } \frac{1-g(x)}{\alpha}$  where the g.l.b is taken over all  $x, \alpha$ , such that  $x \in G', \alpha > 0$  in  $Q$ ,

and  $x + \alpha x_0 \in E$ ;  $B = \sup \frac{g(x)-1}{\alpha}$  where the l.u.b. is taken over all  $x, \alpha$  such that  $x \in G', \alpha > 0$  in  $Q$  and  $x - \alpha x_0 \in E$ . As  $E$  is  $Q$ -radial at 0, for any  $x$  in  $G'$ , there exists  $\beta, \beta > 0, \beta \in Q$  and  $\beta(x+x_0) \in E$ ; so with  $y = \beta x \in G', y + \beta x_0 \in E$ . We deduce at least that  $A$  is not  $+\infty$ . In the same way, we can prove that  $B$  is not  $-\infty$ . Our choice of  $y_0$  must now be such that  $B \leq y_0 \leq A$ . Therefore, it only remains to prove that  $B \leq A$ . This amounts to showing that for all  $x_1 \in G', \alpha_1 \in Q, \alpha_1 > 0$  and  $x_1 - \alpha_1 x_0 \in E$ ;  $x_2 \in G', \alpha_2 \in Q, \alpha_2 > 0$  and  $x_2 + \alpha_2 x_0 \in E$ :

$$\frac{g(x_1)-1}{\alpha_1} \leq \frac{1-g(x_2)}{\alpha_2}$$

which, using the additivity of  $g$  on  $G'$ , can be written as

$$g\left(\frac{\alpha_2}{\alpha_1+\alpha_2} x_1 + \frac{\alpha_1}{\alpha_1+\alpha_2} x_2\right) \leq 1$$

But as both  $x_1 - \alpha_1 x_0$  and  $x_2 + \alpha_2 x_0$  belong to  $E$ , and from the  $Q$ -convexity of  $E$ , we notice that

$$\frac{\alpha_2}{\alpha_1+\alpha_2} x_1 + \frac{\alpha_1}{\alpha_1+\alpha_2} x_2 = \frac{\alpha_2}{\alpha_1+\alpha_2} (x_1 - \alpha_1 x_0) + \frac{\alpha_1}{\alpha_1+\alpha_2} (x_2 + \alpha_2 x_0) \in E$$

Therefore  $g\left(\frac{\alpha_2}{\alpha_1+\alpha_2} x_1 + \frac{\alpha_1}{\alpha_1+\alpha_2} x_2\right) \leq 1$  by our construction of  $g$ . This

ends the proof of Theorem 4.2.

Note The identity of  $g: Q \rightarrow Q$  is bounded above by 1 on  $[-1, +1] \cap Q$ .

It can also be extended (Theorem 4.1) into an additive  $f: \mathbb{R} \rightarrow Q$ .

The extension can never be bounded above by 1 on  $[-1, +1]$  as this would

imply the continuity of the extension, so that the range would no longer be  $Q$ . Therefore we have to choose  $\mathbb{R}$ , and not  $Q$  only, for the range of values of  $f$  for Theorem 4.2 and Corollary 4.2. During the proof, we explicitly used Inf and Sup which are not always defined within  $Q$ .

It could be interesting to generalize Theorem 4.2 to groups  $F$  other than  $\mathbb{R}$  and with other conditions than  $f(x) \leq 1$ .

Let us now come back to some conditional Cauchy equations of type II, precisely of type II<sub>2</sub>.

4.2  $Z$  is a triangle:  $Z = \{(x,y) \mid (x,y) \in X \times X, x+y \in X\}$  in the abelian case.

**Definition 4.3** A non empty subset  $X$  of a divisible abelian group  $G$  is "full" in  $G$  when the two following conditions are satisfied:

- (a) for all  $x \in X$ , and all  $\alpha \in \mathbb{Q}$ ,  $0 < \alpha \leq 1$ ,  $\alpha x \in X$   
 (b) for any pair  $(x,y) \in X \times X$ , there exists an integer  $n$ ,

which may depend upon  $x$  and  $y$ , such that  $\frac{1}{n}(x+y) \in X$ .

The intervals  $]0,1[$  or  $[0,1]$  are full in  $\mathbb{R}$ . A  $\mathbb{Q}$ -convex subset containing 0, is full on a divisible abelian group  $G$ . The following result holds:

**Theorem 4.3** Let  $F$  and  $G$  be abelian divisible groups and let  $X$  be a full subset of  $G$ . Take the triangle  $Z = \{(x,y) \mid (x,y) \in X \times X; x+y \in X\}$  and suppose  $f: G \rightarrow F$  to be  $Z$ -additive. Then there exists an additive  $g: G \rightarrow F$  such that  $f = g$  on  $X$ . Moreover,  $g$  is unique if and only if the subgroup generated by  $X$  is  $G$ .

**Proof** Let  $nX$  be the set of all  $x_1 + \dots + x_n$  where  $x_i \in X$  for  $i = 1, \dots, n$  and take  $Y = \bigcup_{n=1}^{\infty} nX$  to be the subsemi-group generated by  $X$ . We obviously assume  $X \neq \emptyset$ . First we prove that if  $y = x_1 + \dots + x_n$ ,  $x_i \in X$ , there exists an integer  $N$  such that any multiple  $p$  of  $N$  yields  $y/p \in X$  with

$$f\left(\frac{y}{p}\right) = \frac{f(x_1) + \dots + f(x_n)}{p}$$

The proof is by induction on  $n$ . For  $n = 1$  let us prove that  $N$  can be chosen as 1. For any integer  $p$ , due to (a),  $k \frac{y}{p} \in X$  for  $1 \leq k \leq p$ . Moreover, for  $1 \leq k < p$ , we see that  $k \frac{y}{p} \in X$ ,  $\frac{y}{p} \in X$  and  $\frac{k+1}{p} y \in X$ . Therefore,  $f$  being  $Z$ -additive, we first obtain the following equation

$$f\left(\frac{k+1}{p} y\right) = f\left(\frac{k}{p} y\right) + f\left(\frac{y}{p}\right),$$

and so, by induction,

$$f(y) = p f\left(\frac{y}{p}\right).$$

Suppose our lemma to be true up to  $(n-1)$ , which gives an  $N_1$  for  $z = x_1 + \dots + x_{n-1}$ . Since  $\frac{z}{N_1} \in X$  and  $\frac{x_n}{N_1} \in X$ , there exists  $N_2$  and  $\frac{z}{N_1 N_2} \in X$ ,  $\frac{x_n}{N_1 N_2} \in X$ ,  $\frac{z+x_n}{N_1 N_2} \in X$ . Let now  $p$  be any multiple of  $N_1 N_2$ . We may write  $f\left(\frac{x_1 + \dots + x_n}{p}\right) = f\left(\frac{x_1 + \dots + x_{n-1}}{p} + \frac{x_n}{p}\right)$  and so we compute that

$$\begin{aligned} f\left(\frac{x_1 + \dots + x_n}{p}\right) &= f\left(\frac{x_1 + \dots + x_{n-1}}{p}\right) + f\left(\frac{x_n}{p}\right) = \frac{1}{p} (f(x_1) + \dots + f(x_{n-1})) + \frac{1}{p} f(x_n) \\ &= \frac{1}{p} (f(x_1) + \dots + f(x_n)) \end{aligned}$$

We now turn to the proof of Theorem 4.3. For  $y \in Y$ , that is for  $y = x_1 + \dots + x_n$  for example, we define  $\tilde{f}(y) = f(x_1) + \dots + f(x_n)$ . For this definition to make sense, let us suppose that

$$y = x_1 + \dots + x_n = x'_1 + \dots + x'_m,$$

$x_i, x'_j \in X$  for  $i = 1, \dots, n$  and  $j = 1, \dots, m$ . There exists an integer  $p$  for which our intermediate result can be used for both  $x_1 + \dots + x_n$  and  $x'_1 + \dots + x'_m$ . Therefore

$$f\left(\frac{y}{p}\right) = \frac{f(x_1) + \dots + f(x_n)}{p} = \frac{f(x'_1) + \dots + f(x'_m)}{p}.$$

This proves that  $\tilde{f}: Y \rightarrow F$  is well defined. Moreover, via our

definition,  $\tilde{f}$  is additive on the subsemi-group  $Y$ . We may extend  $\tilde{f}$  arbitrarily to the whole of  $G$  as Theorem 4.1 yields an additive function  $g$  on  $G$  which coincide with  $\tilde{f}$  on  $Y$ . Therefore  $g: G \rightarrow F$  coincides with  $f$  on  $X$ . This ends the proof of Theorem 4.3 as the uniqueness result is a consequence of Corollary 4.1. We may wish to extend Theorem 4.3 to some subset  $Z$  of  $G \times G$  which can be squeezed between two conveniently chosen sets. We now escape from strict type II for our conditional Cauchy equations. Some notations are helpful. Let  $X$  be a subset of  $G$ . By  $T(X)$  we define the triangle

$$T(X) = [(x,y) | (x,y) \in G \times G; x \in X, y \in X \text{ and } x + y \in X].$$

Let  $Z$  be a subset of  $G \times G$ . We take  $t(Z)$  to be

$$t(Z) = [z | z \in G; z = x + y \text{ where } (x,y) \in Z].$$

We keep the notation  $nX = [z | z \in G; z = x_1 + \dots + x_n]$  where  $x_i \in X$  for  $i = 1, 2, \dots, n$ .

Theorem 4.4 Let  $F$  and  $G$  be divisible abelian groups. Let  $Z$  be a subset of  $G \times G$  such that there exists a full subset  $X$  of  $G$  for which

$$T(X) \subset Z \subset X \times X$$

Condition  $(Z, G, F)$  is quasi-redundant. Moreover the additive extension  $g$  is unique if and only if the divisible subgroup of  $G$  generated by  $X$  is  $G$ .

Proof Clearly,  $f: G \rightarrow F$  is  $T(X)$ -additive and Theorem 4.3 yields an additive  $g: G \rightarrow F$  with  $g = f$  on  $X$ . By definition  $t(T(X)) \subset X$ .

But if  $x \in X$ , then  $x/2 \in X$  and from  $x = x/2 + x/2$ , we deduce  $t(T(X)) = X$ . Thus  $t(Z) \supset X$ . In fact,  $f$  and  $g$  are equal on  $t(Z)$ . To see this, take now  $z = x + y$  in  $t(Z)$  where  $(x,y) \in Z$ . As  $x$  and  $y$  are in  $X$  ( $Z \subset X \times X$ ), we get

$$\begin{aligned} g(z) &= g(x+y) = g(x) + g(y) \\ &= f(x) + f(y) = f(x+y) \\ &= f(z) \end{aligned}$$

yielding  $f(z) = g(z)$  for all  $z$  in  $t(Z)$ .

If the divisible subgroup generated by  $X$  is  $G$ , then  $g$  is unique.

Conversely,  $g$  is uniquely defined on the divisible subgroup  $G_0$  which is generated by  $t(Z)$ . But this subgroup  $G_0$  is also the divisible subgroup generated by  $X$  as  $X$  is full. If  $G_0 \neq X$ , Corollary 4.1 proves that  $g$  is not unique. As a consequence of Theorem 4.4 and Theorem 1.2, we deduce the following:

Corollary 4.3 Let  $f: \mathbb{R} \rightarrow \mathbb{R}$  be a  $Z$ -additive function where

$$Z = [(x,y) | (x,y) \in \mathbb{R}^2; x \geq 0, y \geq 0, x^2 + y^2 \leq r^2]$$

or

$$Z = [(x,y) | (x,y) \in \mathbb{R}^2, 0 \leq x \leq r; 0 \leq y \leq r]$$

for some  $r > 0$ .

Suppose  $f$  is bounded above on a subset of positive Lebesgue measure of  $[0, \sqrt{2}r]$  (or  $[0, 2r]$ ). Then  $f(x) = ax$  for some  $a$  in  $\mathbb{R}$  and for all  $x$  in  $[0, \sqrt{2}r]$  (or  $x \in [0, 2r]$ ).

Note 1 There does not exist a converse result for Theorem 4.4. How can one characterize those  $Z \subset G \times G$  for which any  $Z$ -conditional Cauchy solution  $f: G \rightarrow F$  is equal to a Cauchy solution on  $t(Z)$ ?

Conditions given in Theorem 4.4 should not be very far from a necessary condition. A good setting for such a question will be given with Theorem 4.5.

Note 2 In a divisible abelian group, a full subset is not necessarily a  $Q$ -convex subset. For example, in  $G = \mathbb{R}$ , let  $X = [z | z \in \mathbb{R}; z = \alpha + \beta\sqrt{2}, \alpha \in Q, \beta \in Q, \sqrt{|\alpha|} + \sqrt{|\beta|} \leq 1]$ . It is a full subset of  $\mathbb{R}$  but not a  $Q$ -convex subset (as 1 and  $\sqrt{2}$  are in  $X$ , but then  $\frac{1+\sqrt{2}}{2} \notin X$ ).

Note 3 In both Theorems 4.3 and 4.4, the identity of the group  $G$  plays an important part, even if 0 does not necessarily belong to a full subset. If we now suppose  $0 \in X$ , we may translate without change the properties of 0 to any point in  $G$ . With the notion of quasi-extension to be defined, we shall obtain a characterization of solutions of Cauchy conditional equations under fairly general conditions. First let us introduce some notations. We denote by  $p_1$  and  $p_2$  the following projections

$$p_1: G \times G \rightarrow G \quad p_1(x, y) = x$$

$$p_2: G \times G \rightarrow G \quad p_2(x, y) = y$$

Definition 4.4 Let  $G, F$  be abelian groups. Let  $Z$  be a non empty subset of  $G \times G$ . An additive mapping  $g: G \rightarrow F$  is a quasi extension relative to  $Z$  of a mapping  $f: G \rightarrow F$  if there exists  $(x_0, y_0) \in Z$  and

$$f(x) - f(x_0) - f(y_0) = g(x) - g(x_0) - g(y_0) \quad \text{for all } x \in t(Z)$$

$$f(x) - f(x_0) = g(x) - g(x_0) \quad \text{for all } x \in p_1(Z)$$

$$f(y) - f(y_0) = g(y) - g(y_0) \quad \text{for all } y \in p_2(Z)$$

If  $f(x_0) = f(y_0) = g(x_0) = g(y_0) = 0$ , a quasi-extension  $g$  of  $f$  (relative to  $Z$ ) coincides with  $f$  on  $p_1(Z)$ ,  $p_2(Z)$  and  $t(Z)$ . (cf also Note 4 to come). With such a notion, we get

Theorem 4.5 Let  $X$  be a full subset containing the origin in a divisible abelian group  $G$ . Let  $F$  be a divisible abelian group. Let  $Z'$  be in  $G \times G$  such that  $T(X) \subset Z' \subset X \times X$ . Let  $x_0, y_0$  two elements of  $G$ . Let  $Z = (x_0, y_0) + Z'$ .

A mapping  $f: G \rightarrow F$  is a solution of a conditional Cauchy equation relative to  $Z$  if and only if there exists an additive  $g: G \rightarrow F$  which is a quasi-extension of  $f$  relative to  $Z$ .

Proof Suppose  $f: G \rightarrow F$  possesses a quasi-extension  $g: G \rightarrow F$  relative to  $Z$ . Let  $(x, y) \in Z$ . Then  $x + y \in t(Z)$  so that for some  $(x_1, y_1) \in Z$ .

$$f(x+y) - f(x_1) - f(y_1) = g(x+y) - g(x_1) - g(y_1)$$

But  $x$  is in  $p_1(Z)$  and so

$$f(x) - f(x_1) = g(x) - g(x_1)$$

In the same way as  $y$  is in  $p_2(Z)$

$$f(y) - f(y_1) = g(y) - g(y_1)$$

We deduce by substituting the last two equations to the first one

$$f(x+y) - f(x) - f(y) = g(x+y) - g(x) - g(y) = 0$$

Therefore  $f: G \rightarrow F$  is  $Z$ -additive. (We made no use in this part of the proof, of properties of  $Z$ ,  $G$  or  $F$ ).

Conversely let  $f: G \rightarrow F$  be a  $Z$ -conditional Cauchy equation.

If  $x_0 = y_0 = 0$  (or  $Z' = Z$ ) we deduce  $f(x_0) = f(y_0) = 0$  and

Theorem 4.4 yields an additive  $g: G \rightarrow F$  such that  $g = f$  on  $t(Z)$ .

But  $p_1(Z) \subset X$ ,  $p_2(Z) \subset X$  and we already noticed (Theorem 4.4)  $t(Z) \supset X$ .

Therefore  $g$  is a quasi-extension of  $f$  relative to  $Z$ .

In the general case, let us define  $\tilde{f}: G \rightarrow F$

$$(1) \quad \tilde{f}(x) = f(x+x_0+y_0) - f(x_0) - f(y_0)$$

The mapping  $\tilde{f}$  can be shown to be  $Z'$ -additive. We proceed as follows

with  $(x', y') \in Z'$

$$f(x'+y'+x_0+y_0) = f(x'+x_0) + f(y'+y_0) \text{ as } f \text{ is } Z\text{-additive.}$$

or

$$(2) \quad \tilde{f}(x'+y') = f(x'+x_0) - f(x_0) + f(y'+y_0) - f(y_0)$$

But  $(x', y') \in Z'$  yields  $(x', 0) \in Z'$  and  $(0, y') \in Z'$  as for example,

$x' \in X (Z' \subset X \times X)$  as well as  $0 \in X$  and so  $(x', 0) \in T(X)$  which proves

$(x', 0) \in Z'$  because of  $T(X) \subset Z'$ .

Eq (2) with  $y' = 0$  (or with  $x' = 0$ ) yields for  $x' \in p_1(Z')$

(or  $y' \in p_2(Z')$ )

$$(3) \quad \tilde{f}(x') = f(x'+x_0) - f(x_0) \text{ and } (4) \quad \tilde{f}(y') = f(y'+y_0) - f(y_0)$$

Eq (2) now becomes for all  $(x', y') \in Z'$

$$\tilde{f}(x'+y') = \tilde{f}(x') + \tilde{f}(y')$$

As we have seen in the case  $x_0 = y_0 = 0$ , there exists an additive

$g: G \rightarrow F$  for which  $g = \tilde{f}$  on  $t(Z')$ . For  $z' \in t(Z')$

$$(5) \quad f(z'+x_0+y_0) - f(x_0) - f(y_0) = g(z')$$

Let  $z$  be in  $t(Z)$ . There exists  $z'$  in  $t(Z')$  with  $z = z' + x_0 + y_0$

and

$$f(z) - f(x_0) - f(y_0) = g(z-x_0-y_0) = g(z) - g(x_0) - g(y_0)$$

Let  $x \in p_1(Z)$ . There exists  $x'$  in  $p_1(Z')$  and  $x = x' + x_0$ . But

$x' \in t(Z')$  and so  $\tilde{f}(x') = g(x')$ . Eq (3) yields

$$f(x) - f(x_0) = g(x) - g(x_0)$$

In a similar way, for  $y \in p_2(Z)$ , we get

$$f(y) - f(y_0) = g(y) - g(y_0)$$

This ends the proof of Theorem 4.5.

Note 4 It should be noticed that if we have a quasi-extension  $g$  relative to  $Z$  and using  $(x_0, y_0) \in Z$ , then  $g$  is as well a quasi-extension relative to  $Z$  for any  $(x_1, y_1) \in Z$ .

Note 5 Within the conditions of Theorem 4.5, there exists a unique quasi-extension relative to  $Z$  for a  $Z$ -additive function if and only if the divisible subgroup generated by  $X$  in  $G$  coincides with  $G$ .

Corollary 4.4 Let  $Z$  be a non empty, open and connected subset of  $\mathbb{R}^2$ .

Suppose  $f$  is  $Z$ -additive and bounded above on a subset of positive Lebesgue measure of  $t(Z)$ . There exist constants  $a, b$  in  $\mathbb{R}$  such that for all  $x$  in  $t(Z)$ :

$$f(x) = ax + b$$

Proof As  $Z$  is non empty and open, for each  $(x_0, y_0)$  in  $Z$ , there exists an  $r > 0$  and the disc  $C(x_0, y_0, r)$ , centered at  $(x_0, y_0)$  and of radius  $r$ , is included in  $Z$ . We apply Theorem 4.5 with

$Z = C(x_0, y_0, r)$  and  $X = [0, r[$ . Therefore  $f(x+y) = g(x+y)$  for all  $(x, y) \in C(x_0, y_0, r)$  where  $g: \mathbb{R} \rightarrow \mathbb{R}$  is additive.

Suppose now  $t(C(x_0, y_0, z))$  and  $t(C(x_1, y_1, z'))$  have a non empty intersection, which is an open interval  $I$  or  $\mathbb{R}$ . We get for  $z$  in  $I$ :  $f(z) = g(z) + \alpha = g'(z) + \alpha'$ . Therefore  $g - g'$  is an additive function, bounded on  $I$ . Theorem 1.1 yields that  $g(z) - g'(z) = \beta z$  and the equation provides us with  $\beta = 0$ . We deduce that  $\alpha = \alpha'$ .

Now using the connectedness of  $Z$ , we conclude that

$$f(z) = g(z) + b \quad \text{for all } z \text{ in } t(Z)$$

where  $b$  is some real constant. As  $f$  is bounded above on a subset of positive Lebesgue measure of  $t(Z)$ ,  $g(z) = az$  for some  $a$  in  $\mathbb{R}$ .

In general, it must be noticed that  $f$  is not necessarily an affine function on  $E = t(Z) \cup p_1(Z) \cup p_2(Z)$ . Even if we suppose  $f$  continuous,  $f$  will only be a piecewise affine function on  $E$  in general.

### 4.3 Hamel bases

Let  $G$  be a non trivial divisible abelian group and consider all non empty subsets  $H$  of  $G \setminus \{0\}$  such that for all  $n \geq 1$  an equation like  $\sum_{i=1}^n n_i h_i = 0$ , where  $n_i \in \mathbb{Z}$  and  $h_i \in H$ , implies  $n_i = 0$  for all  $i = 1, 2, \dots, n$ . (Independence property of  $H$  over  $\mathbb{Z}$ ).

We order the non empty family  $F$  of all such  $H$  by inclusion. Applying Hausdorff's maximality theorem, there exists a maximal totally ordered subset  $F'$  of  $F$ . Define  $H$  to be the union of all  $H'$  in  $F'$ . It is easy to check that  $H$  is a maximal element of  $F'$ .

Let us prove that the set of all  $x$  for which there exists an  $n \geq 1$  such that (1)  $x = \alpha_1 h_1 + \dots + \alpha_n h_n$  for some  $\alpha_1, \alpha_2, \dots, \alpha_n \in \mathbb{Q}$  and  $h_1, h_2, \dots, h_n \in H$ , is in fact the whole of  $G$ . We first notice that a decomposition as in (1), if it exists for some  $x$ , is unique due to the independence property of  $H$  over  $\mathbb{Z}$ . (Reduce to the same denominator). So, suppose that (1) is not possible for some  $x_0$  in  $G$  and all possible choices of  $n, \alpha_i, h_i$ . Then  $H \cup \{x_0\}$  has the independence property over  $\mathbb{Z}$  as a non trivial equation like

$$n_0 x + \sum_{i=1}^n n_i h_i = 0 \quad n_i \in \mathbb{Z} \quad i = 0, 1, \dots, n$$

cannot be true for  $n_0 \neq 0$  by our hypothesis and cannot be true for  $n_0 = 0$  by the independence of  $H$  over  $\mathbb{Z}$ . Thus  $H \cup \{x_0\}$  dominates  $H$  which is impossible. Let us state what we have proved in the form of a Definition.

Definition 4.5 Let  $G$  be a non trivial divisible abelian group. A subset  $H$  of  $G$  such that every  $x$  in  $G$  can be written in a unique way in the form



$$x = \sum_{i=1}^n \alpha_i h_i$$

for some integer  $n \geq 1$ , some  $\alpha_i$  in  $Q$  and  $h_i$  in  $H$ , is called a Hamel basis for  $G$ . Such a  $G$  always possesses a Hamel basis.

Note A divisible abelian group is another aspect of a linear space over the field of rational numbers. A Hamel basis is just a basis for such a linear space over  $Q$ . However, to avoid confusion, we shall not use here the terminology of linear spaces because generally one is accustomed to working in linear spaces over real or complex numbers. A good example comes with  $\mathbb{R}$ , the field of all real numbers. It is a linear space over  $\mathbb{R}$  of dimension 1 but it is also a linear space of infinite dimension over  $Q$ . A Hamel basis for  $\mathbb{R}$  is a subset of non-zero real elements such that for every real number  $x$  there exists an integer  $n$  ( $n \geq 1$ ),  $n$  rational numbers  $\alpha_1, \alpha_2, \dots, \alpha_n$  and  $n$  elements  $h_1, \dots, h_n$  of  $H$  such that

$$(1) \quad x = \alpha_1 h_1 + \dots + \alpha_n h_n$$

This decomposition is unique. Clearly, a Hamel basis leads to the general solution of the Cauchy equation.

Theorem 4.6 Let  $G, F$  be divisible abelian groups and  $H$  be a Hamel basis for  $G$ . The set of restrictions of all solutions of the Cauchy equation  $f: G \rightarrow F$  coincides with the set of all functions from  $H$  into  $F$ .

Take any  $f: H \rightarrow F$ . We define  $\bar{f}$  by additivity on all of  $G$  according to

$$(2) \quad x = \sum_{i=1}^n \alpha_i(x) h_i \quad \alpha_i(x) \in Q, h_i \in H$$

$$(3) \quad \bar{f}(x) = \sum_{i=1}^n \alpha_i(x) f(h_i)$$

Clearly  $\bar{f}: G \rightarrow F$  is additive, as (2) is unique, whereby  $\bar{f}$  extends  $f$  to all of  $G$ . For the sake of convenience, we shall write (2) in the form  $\sum_f \alpha h$  (where  $\sum_f$  indicates a finite sum). We immediately deduce from Theorem 4.6 that there exist very pathological solutions for the Cauchy equation, even in the case  $G = F = \mathbb{R}$ . Consider an additive and continuous  $f: \mathbb{R} \rightarrow \mathbb{R}$ . It has the form  $f(x) = ax$  for some  $a$  in  $\mathbb{R}$ . Let  $H$  be a Hamel basis for  $\mathbb{R}$ . For  $h, h'$  in  $H$ , we deduce

$$hf(h') = h'f(h)$$

Therefore the value of a continuous and additive function at a given element of  $H$  completely determines  $f$ . By arbitrary choices of  $f$  on  $H$ , we have much freedom to build up non continuous additive Cauchy solutions on  $\mathbb{R}$ .

It should not be thought that pathological solutions, of which there are many, are irrelevant in analysis. In Chapter III, §5, with almost periodic functions and the Bohr group  $B$ , we already pointed out their importance.

By the way, cardinality provides a nice way to measure the size of the set of all regular additive functions from  $\mathbb{R}$  into  $\mathbb{R}$  as compared to the size of the set of all additive functions from  $\mathbb{R}$  into  $\mathbb{R}$ .



A Hamel basis of  $\mathbb{R}$  has the same cardinality as  $\mathbb{R}$  itself. To see this we notice that the set of all  $x$  in  $\mathbb{R}$ , written in the form

$$(4) \quad x = \sum_f \alpha_h h$$

for a given finite subset  $h_1, h_2, \dots, h_n$  of  $H$  is countable like  $\mathbb{Q}$ . Therefore  $H$  cannot be finite as  $\mathbb{R}$  is not countable. But the set of all finite subsets of  $H$  has the same cardinality as  $H$  because it is a countable union of sets of the same cardinality as  $H$  (The family of all subsets of one element, which is  $H$ , the family of all subsets of two elements, which is included in  $H^2$ , etc...). We deduce that the set of all  $x$  which can be written in the form (1) has the cardinality of  $H$ . It coincides with  $\mathbb{R}$ , which ends the proof

$$\text{Card } H = \text{Car } \mathbb{R} = \aleph_1$$

Regular additive functions from  $\mathbb{R}$  into  $\mathbb{R}$  (continuous ones for instance) are determined by specifying one value on some element of  $H$ . The set of all such functions has the cardinality  $\aleph_1$  of  $\mathbb{R}$ . On the contrary the set of all additive functions from  $\mathbb{R}$  into  $\mathbb{R}$  is isomorphic to the product  $\mathbb{R}^H$  or the set of all numerical functions over  $H$  (Th. 4.6). The cardinality of  $\mathbb{R}^H$ , which coincides with that of  $\mathbb{R}^{\mathbb{R}}$  is  $2^{\aleph_1} = \aleph_2$ , strictly greater than  $\aleph_1$  through the famous theorem of Cantor.

With the help of Theorem 4.6, we see that there exist additive and discontinuous bijections from  $\mathbb{R}$  onto  $\mathbb{R}$ . (As two Hamel bases for  $\mathbb{R}$  have the same cardinal, there exist between two such bases  $H$  and  $H'$  a bijection  $f$ . Such a bijection can be extended ( $\bar{f}$ ) by additivity to

the whole of  $\mathbb{R}$ .  $\bar{f}: \mathbb{R} \rightarrow \mathbb{R}$  is a bijection, is additive, but is not continuous if there exists no  $a$  in  $\mathbb{R}$  such that  $f(h) = ah$  for all  $h$  in  $H$ ). For the sake of completeness, let us give an opposite result to Corollary 1.2. Let  $f: \mathbb{R} \rightarrow \mathbb{R}$  be an additive, discontinuous but not one-to-one function. Let  $x$  be in the range of  $f$ . Then  $f^{-1}(x)$  is dense in  $\mathbb{R}$ . (For the proof, it suffices to show the density of  $\ker f$ , the kernel of  $f$ . It is a divisible subgroup of  $\mathbb{R}$ . Therefore  $\text{Inf}\{x \mid x \in \mathbb{R}, x > 0, x \in \ker f\} = 0$ . For any open interval  $]a, b[$ ,  $a < b$ , there exists  $h \in \ker f$  and  $0 < h < b - a$ . Let  $n_0$  be an integer such that  $n_0 h < b \leq (n_0 + 1)h$ . We get  $n_0 h$  in  $\ker f$  and  $a < b - h \leq n_0 h$  so that  $n_0 h \in ]a, b[$ . Thus  $H$  is dense in  $\mathbb{R}$ ). One may easily guess, after Theorem 1.1 or 1.2, that a Hamel basis possesses "unsuspected" behaviour and for that reason may lead easily to counterexamples.

One way to look at such pathological properties is to consider the set of all positive elements  $H^+$  of a given Hamel basis  $H$  of  $\mathbb{R}$ . It may happen that  $H^+ = H$  since for any Hamel basis  $H$  of  $\mathbb{R}$ , the set  $H' = [|h|; h \in H]$  is also a Hamel basis. However, if we consider the set  $E$  of all  $x = \sum_{i=1}^n \alpha_i h_i$ , for any  $n \geq 1$ ,  $\alpha_i \in \mathbb{Q}^+$  (positive rational numbers and zero) and  $h_i \in H^+$ , then  $E$  never coincides with the set  $\mathbb{R}^+ = [x \mid x \in \mathbb{R}; x \geq 0]$ . For example, let  $h_1, h_2$  in  $H^+$  with  $h_2 > h_1$ . Then  $h_2 - h_1 \in \mathbb{R}^+$ , but cannot be written in the form  $\sum_{i=1}^n \alpha_i h_i$  for  $\alpha_i \in \mathbb{Q}^+$  and  $h_i \in H^+$ . Otherwise  $0 = (\alpha_1 + 1)h_1 + (\alpha_2 - 1)h_2 + \sum_{i=3}^n \alpha_i h_i$  where  $\alpha_1 + 1 > 0$  ( $\alpha_1 \geq 0$ ), which contradicts the independence property of  $H$ .

Another property of Hamel bases is striking. Since every real number can be written as a finite rational combination of elements of the Hamel basis, the number of elements of a given Hamel basis which are necessary (i.e. with a non zero coefficient) for the writing of all elements of a given open interval  $]a, b[$ ,  $a < b$  is infinite. We can get more.

Proposition 4.1 Let  $H$  be a Hamel basis of  $\mathbb{R}$ . Let  $n$  be a given integer. The subset  $E_n$  of all  $\alpha_1 h_{i_1} + \dots + \alpha_n h_{i_n}$  for all possible choices of  $n$  elements  $\alpha_1, \dots, \alpha_n$  in  $\mathbb{Q}$  and  $n$  elements  $h_{i_1}, \dots, h_{i_n}$  of  $H$ , contains no subset of positive Lebesgue measure.

Let  $E_n$  be the subset as described in the Proposition 4.1 and suppose  $E_n$  contains  $F$ , a subset of positive Lebesgue measure. Clearly  $E_{2n} \supset F + F$  and by Lemma 1.1,  $F + F$ , therefore  $E_{2n}$ , contains an open interval  $]a, b[$ ,  $a < b$ . If  $x$  is given in  $]a, b[$  and  $x = \alpha_1 h_{i_1} + \dots + \alpha_{2n} h_{i_{2n}}$ ,  $\alpha_i \in \mathbb{Q}$ , we get with any  $h_0, h_0 \in H$  and  $h_0 \neq h_{i_j}$ ,  $j = 1, 2, \dots, 2n$ , that  $x + \alpha h_0 \in ]a, b[$  for some sufficiently small rational  $\alpha$ . If all  $\alpha_i \neq 0$ , then  $x + \alpha h_0 \in E_{2n}$  which contradicts its belonging to  $]a, b[$ . If some of the  $\alpha_i$  are zero, just add enough terms like  $\alpha h_0$  with other elements of  $H$  to get the contradiction. Therefore, Proposition 4.1 proves that a Hamel basis contains no subset of positive Lebesgue measure. We can even go further, but first need a definition.

Definition 4.6 The  $\mathbb{Q}$ -convex hull  $Q(E)$  of a subset  $E$  of  $\mathbb{R}$  is the smallest  $\mathbb{Q}$ -convex subset of  $\mathbb{R}$  containing  $E$ .

$Q(E)$  is the set of all  $x = \alpha_1 x_1 + \dots + \alpha_n x_n$  where  $\alpha_i \geq 0$ ,  $\alpha_i \in \mathbb{Q}$ ,

$$\sum_{i=1}^n \alpha_i = 1, x_1, x_2, \dots, x_n \in E \text{ and for all } n \geq 1.$$

Proposition 4.2 The  $\mathbb{Q}$ -convex hull of a Hamel basis in  $\mathbb{R}$  contains no subset of positive Lebesgue measure.

Suppose  $Q(H) \supset E$ , where  $E$  is of positive Lebesgue measure and  $H$  a Hamel basis. Then  $Q(H) + Q(H)$  contains an open interval (Lemma 1.1). Let  $f(H) = 1$  and extend  $f$  by additivity to all of  $\mathbb{R}$  (Theorem 4.6).

Clearly  $f$  remains bounded from above on  $Q(H)$  and on  $Q(H) + Q(H)$ .

Theorem 1.1 yields the continuity of  $f$  which contradicts  $f(H) = 1$ .

On the other hand, instead of looking at subsets which are not included in a Hamel basis, let us look at those subsets including a Hamel basis.

Any interval  $[a, b]$ ,  $a < b$ , contains some Hamel basis. Just notice that for any  $\alpha$ ,  $\alpha \neq 0$  and in  $\mathbb{Q}$ , if  $H$  is a Hamel basis for  $\mathbb{R}$ , and  $h_0$  some element of  $H$ , then  $(H \setminus [h_0]) \cup [\alpha h_0]$  is also a Hamel basis. To conclude, we notice that for any  $h \in H$ , there exists  $\alpha$ , a non zero rational number, with  $\alpha h \in [a, b]$  as  $\mathbb{Q}h$  is dense in  $\mathbb{R}$ . We may state a consequence as a Corollary.

Corollary 4.5 Two solutions of the Cauchy functional equation, from  $\mathbb{R}$  into  $\mathbb{R}$ , which are equal on an interval  $[a, b]$ ,  $a < b$ , are equal everywhere.

Clearly Corollary 4.5 can also be proved as a consequence of Theorem 1.1, should we notice that the difference of two additive functions is also an additive function. In doing so, we may immediately state another result.

Corollary 4.6 Any subset  $E$  of  $\mathbb{R}$ , of positive Lebesgue measure, contains a Hamel basis.

However, it may be noticed that a subset of zero Lebesgue measure, such as the Cantor set, (cf Chapter III, sequel of Corollary 3.1) may very well contain a Hamel basis. To prove this, and to prove Corollary 4.6, it suffices to show the validity of the following proposition.

Proposition 4.3 A subset  $E$  of  $\mathbb{R}$  contains a Hamel basis if and only if any  $f: \mathbb{R} \rightarrow \mathbb{R}$ , additive and equal to zero on  $E$ , is identically equal to 0.

Once Proposition 4.3 is proved, Corollary 4.6 is easy. Let  $E$  be a subset of positive Lebesgue measure in  $\mathbb{R}$  and let  $f: \mathbb{R} \rightarrow \mathbb{R}$  be an additive function, equal to zero on  $E$ . Due to Theorem 1.2,  $f$  is necessarily continuous and therefore identically equal to zero on all of  $\mathbb{R}$ . Thus  $E$  contains a Hamel basis by Proposition 4.3. In the same way, if  $E$  is the Cantor set and  $f: \mathbb{R} \rightarrow \mathbb{R}$  an additive function, zero on  $E$ , then  $\frac{E+E}{2} = [0,1]$  implies that  $f$  is zero on  $[0,1]$ , therefore continuous (Theorem 1.1) and zero everywhere. Proposition 4.3 shows that the Cantor set contains a Hamel basis.

Proof of Proposition 4.3 If  $E$  contains a Hamel basis, and if  $f: \mathbb{R} \rightarrow \mathbb{R}$  is additive on  $\mathbb{R}$ , and zero on  $E$ , then, from Theorem 4.6,  $f$  is identically zero.

Conversely, let us prove that a subset  $E$  of  $\mathbb{R}$ , such that any additive function, zero on  $E$ , is necessarily identically zero, must contain a Hamel basis. Start then from a Hamel basis  $H$  for which there exists an  $h_0 \in H$  and  $h_0 \notin E$ . If it were possible to write any  $x \in E$

as a finite rational combination of elements of  $H$  distinct from  $h_0$ , i.e.

$$x = \sum_{i=1}^n \alpha_i h_i \quad \alpha_i \in \mathbb{Q}; h_i \in H, h_i \neq h_0, i = 1, 2, \dots, n$$

then we might define an additive function,  $f: \mathbb{R} \rightarrow \mathbb{R}$ ; by its values on  $H$  according to  $f(h_0) = 1$  and  $f(h) = 0$  for all  $h$  in  $H$  distinct from  $h_0$ . Clearly  $f(E) = 0$  but a contradiction arises with the definition of  $E$  as  $f$  is not identically zero.

Therefore there exists an  $x_0$  in  $E$  with

$$x_0 = \alpha_0 h_0 + \sum_{i=1}^n \alpha_i h_i \quad \text{where } h_i \neq h_0$$

for  $i = 1, 2, \dots, n$  and  $\alpha_i \in \mathbb{Q} \setminus \{0\}$  for  $i = 0, 1, \dots, n$ . We deduce an expansion for  $h_0$  in terms of  $x_0$  and  $H \setminus \{h_0\}$

$$h_0 = \frac{x_0}{\alpha_0} + \sum_{i=1}^n \left(-\frac{\alpha_i}{\alpha_0}\right) h_i$$

It turns out (and is easily shown) that  $H_1 = (H \setminus \{h_0\}) \cup \{x_0\}$  is a Hamel basis for  $\mathbb{R}$ . Now let us consider the family  $F$  of all  $H_E$  where  $\emptyset \neq H_E = H \cap E$  for some Hamel basis  $H$  in  $\mathbb{R}$ . We put, as a partial order on  $F$ , the inclusion order  $H_E \geq H'_E$  if  $H' \cap E \subset H \cap E$ . What we have already proved shows that  $F$  is not empty. By Hausdorff's maximality theorem, there exists a maximal totally ordered subset  $F'$  of  $F$ . Define  $H$  as the union of all  $H'_E$  for  $H'_E$  in  $F'$ . It clearly possesses the independence property over  $\mathbb{Z}$ , for the verification of such a property only concerns a finite number of elements each time. Such a finite family belongs to some  $H'_E$  in  $F'$ . Clearly too  $H \subset E$ .

It only remains to prove that every  $x \in \mathbb{R}$  can be written as  $\sum_f \alpha h$  for  $h \in H$  and  $\alpha \in \mathbb{Q}$ , as then  $H$  will be a Hamel basis included in  $E$ . Suppose by way of contradiction that there exists an  $h_0$  in  $\mathbb{R}$  which cannot be written as  $\sum_f \alpha h$ . Using, once more, Hausdorff's maximality theorem, we may construct a Hamel basis  $H_0$  containing both  $H$  and  $h_0$ . Due to the first part of our proof, we can then build a Hamel basis  $H_1$ , coinciding with  $H_0 \setminus \{h_0\}$ , except for one additional element from  $E$ . Therefore  $H_1 \cap E$  strictly contains  $H_0 \cap E \supset H$ . But then, by maximality,  $H_1 \cap E$  must belong to  $F'$  which is a contradiction as then we should have  $H_1 \cap E \subset H$ .

In order to generalize Corollary 4.6, so as to include subsets like the Cantor set, we investigate subsets  $E$  with appropriate properties so as to appear as natural candidates for containing a Hamel basis. Let  $E$  be a subset of  $\mathbb{R}$ . By  $nE$ , we denote the set of all  $x = x_1 + x_2 + \dots + x_n$  where  $x_i \in E$  for  $i = 1, 2, \dots, n$ . The union of all  $nE$  is  $F(E) = \bigcup_{n=1}^{\infty} (nE)$ .

Property 1 The subset  $F(E)$  coincides with  $\mathbb{R}$ .

Property 2 The subgroup  $R_E$  generated by  $E$  in  $\mathbb{R}$  coincides with  $\mathbb{R}$ .

Property 3 The subset  $M(E)$  coincides with  $\mathbb{R}$ .

Here  $M(E)$  denotes the following set. Let  $E_1$  be the set of all midpoints of  $E$  ( $x \in E_1$ , if  $x = \frac{x_1 + x_2}{2}$  where  $x_1, x_2$  are in  $E$ ) and more generally let  $E_n$ , for  $n \geq 1$ , be the set of all midpoints of  $E_{n-1}$  with  $E_0 = E$ . Then  $M(E)$  is the union of all  $E_n$  for  $n \geq 0$ .

Property 4 The subset  $Q(E)$ , the convex hull of  $E$ , coincides with  $\mathbb{R}$ .

Property 5 The subset  $\epsilon(E)$  coincides with  $\mathbb{R}$ .

Here  $\epsilon(E)$  is the set of all  $x$  in  $\mathbb{R}$  which can be written as  $\alpha_1 x_1 + \dots + \alpha_n x_n$  where  $\alpha_1, \alpha_2, \dots, \alpha_n$  are in  $\mathbb{Q}$  and  $x_1, x_2, \dots, x_n$  are in  $E$ . (It is the  $\mathbb{Q}$ -linear span of  $E$ ). Property 5 is a necessary and sufficient condition for  $E$  to contain a Hamel basis. (It is obviously a necessary condition as seen from the definition of a Hamel basis. Sufficiency is a simple consequence of Proposition 4.3).

Corollary 4.7 Let  $E$  be a subset of  $\mathbb{R}$  such that  $\epsilon(E)$  contains a subset of positive Lebesgue measure. Then  $E$  contains a Hamel basis.

$\epsilon(E)$  is a (divisible) abelian subgroup of  $\mathbb{R}$ . Due to Lemma 1.1, and using the connectedness of  $\mathbb{R}$ , if  $\epsilon(E)$  contains a subset of positive Lebesgue measure, then it coincides with  $\mathbb{R}$  and so  $E$  contains a Hamel basis which proves Corollary 4.7. We now think of Properties 1', 2', 3', 4' or 5', replacing the expression "coincide with  $\mathbb{R}$ " by the expression "contains a subset of positive Lebesgue measure" in the definition of Properties 1, 2, 3, 4 or 5. Corollary 4.7 asserts that Property 5' is a necessary and sufficient condition for  $E$  to contain a Hamel basis. Corollary 4.7 a fortiori proves that Properties 1', 2', 3' or 4' are sufficient conditions for  $E$  to contain a Hamel basis as well as Properties 1, 2, 3 or 4. However, Properties 1, 2, 3 or 4 as well as Properties 1', 2', 3' or 4', are not necessary conditions for  $E$  to contain a Hamel basis.

Counterexample to the necessity of Property 1. Let  $E = [0, 1]$ . It contains a Hamel basis but  $F(E) = [0, \infty[ \neq \mathbb{R}$ .

Counterexample to the necessity of Property 1' See counterexample to the necessity of Property 2'.

Counterexample to the necessity of Property 2 or Property 2' Let  $H$  be a Hamel basis for  $\mathbb{R}$  and let  $R_H$  be the subgroup generated by  $H$  in  $\mathbb{R}$ . Such a subgroup does not coincide with  $\mathbb{R}$  and even does not contain a subset of positive Lebesgue measure. If it were, then using Lemma 1.1 and the connectedness of  $\mathbb{R}$ , we should get  $R_H = \mathbb{R}$ . But for any  $h$  in  $H$ ,  $h/2$  does not belong to  $R_H$ . To see this, suppose  $h/2 \in R_H$  for some  $h \in H$ . There would exist  $n_1, n_2, \dots, n_k$  in  $\mathbb{Z}$  with  $\frac{h}{2} = n_1 h_1 + \dots + n_k h_k$  where  $h_i \in H$ . Due to the independence of  $H$  over  $\mathbb{Z}$ , it follows that  $2n_1 = 1$ , which is impossible.

Counterexample to the necessity of Property 3 Let  $E = [0, 1]$ . It contains a Hamel basis, but  $M(E) = [0, \infty[ \neq \mathbb{R}$ .

Another construction is perhaps more striking. Let  $H$  be a Hamel basis of  $\mathbb{R}$  and consider  $M(H)$ . Such a subset does not coincide with  $\mathbb{R}$  as it does not contain  $h/p$  for any  $h$  in  $H$  and any prime number  $p$  with  $p > 2$ . (If  $h/p$  were to belong to  $M(H)$ ,  $h \in H$ , there would exist positive integers  $n_1, n_2, \dots, n_k$  such that  $n_1 + n_2 + \dots + n_k = 2^n$  and

$$\frac{h}{p} = \frac{1}{2^n} (n_1 h_1 + \dots + n_k h_k) \quad \text{where } h_i \in H$$

From the independence of  $H$  over  $\mathbb{Z}$ , we deduce that  $2^n = pn_1$  which is impossible).

Counterexample to the necessity of Property 3' See counterexample to the necessity of Property 4'.

Counterexample to the necessity of Property 4 Let  $E = [0, 1]$ . It contains a Hamel basis but  $Q(E) = [0, 1] \neq \mathbb{R}$ .

Counterexample to the necessity of Property 4' Let  $H$  be a Hamel basis. Proposition 4.2 asserts that  $Q(H)$  contains no subset of positive Lebesgue measure.

We are now ready for a study of some converses to such results as Theorems 1.1 or 1.2. We already characterized those subsets  $E$  of  $\mathbb{R}$  for which any additive  $f: \mathbb{R} \rightarrow \mathbb{R}$  zero on  $E$ , is zero everywhere. We shall now characterize those subsets  $E$  of  $\mathbb{R}$  for which any additive  $f: \mathbb{R} \rightarrow \mathbb{R}$ , bounded above on  $E$  (or bilaterally bounded on  $E$ ) is continuous everywhere.

Note Using the vocabulary from measure theory, we could replace the expression

"The subset  $E$  of  $\mathbb{R}$  contains a subset of strictly positive Lebesgue measure"

by the following equivalent expression

"The subset  $E$  has a strictly positive inner Lebesgue measure".

4.4 Converse theorems

Let  $f: \mathbb{R} \rightarrow \mathbb{R}$  be an additive function and consider for an  $M$  in  $\mathbb{R}$ , the subset

$$(1) \quad E = [x | x \in \mathbb{R}; f(x) \leq M]$$

$E$  possesses some interesting properties. We suppose  $f$  not identically zero

If  $x, y$  are in  $E$  and  $\alpha \in \mathbb{Q}$ , with  $0 \leq \alpha \leq 1$ , then  $\alpha x + (1-\alpha)y$  is also in  $E$ . A subset of  $\mathbb{R}$  possessing such a property was called Q-convex. (Definition 4.1)

Let  $x_0 \in E$  such that  $f(x_0) < M$  and  $x$  be a point in  $\mathbb{R}$ . We may find  $\alpha_x > 0$  in  $\mathbb{Q}$  such that  $f(x_0) + \alpha_x |f(x)| \leq M$ . Therefore for any  $\alpha$  in  $\mathbb{Q}$ ,  $0 \leq \alpha \leq \alpha_x$ ,  $x_0 + \alpha x \in E$ . A subset  $E$  of  $\mathbb{R}$  possessing such a property at a point  $x_0$  was called Q-radial at  $x_0$  (Definition 4.2).

Clearly too,  $E$  is not bounded (using  $f(\alpha x) = \alpha f(x)$  for all  $\alpha \in \mathbb{Q}$  and the existence of an  $x \in \mathbb{R}$  such that  $f(x) \leq 0$ )

These three properties almost characterize those subsets of  $\mathbb{R}$  which are of the form (1) for some additive  $f: \mathbb{R} \rightarrow \mathbb{R}$ . The precise answer is as follows.

Proposition 4.4 Let  $E$  be Q-radial at some point  $x_0$  in  $E$  and let us suppose  $E$  to be Q-convex and non empty. Then there exists an additive  $f: \mathbb{R} \rightarrow \mathbb{R}$  and constants  $M, N$  ( $M > N$ ) such that either  $f$  is continuous and  $E \supset [x | x \in \mathbb{R}; N < f(x) < M]$  or  $f$  is discontinuous and  $E \subset [x | x \in \mathbb{R}; f(x) \leq M]$ .

Proof Suppose first that  $O$  is the point  $x_0$  where  $E$  is Q-radial. Note that this implies that  $0 \in E$  and the Q-convexity of  $E$  yields  $\alpha x \in E$  for all  $\alpha$  with  $0 \leq \alpha \leq 1$ ;  $\alpha \in \mathbb{Q}$  and  $x \in E$ .

Now let us suppose that  $E$  is a convex subset of  $\mathbb{R}$  (i.e.  $\alpha x + (1-\alpha)y \in E$  for all  $x, y$  in  $E$ , and all  $\alpha$  in  $\mathbb{R}$  such  $0 \leq \alpha \leq 1$ ). Convex subsets of  $\mathbb{R}$  are  $\mathbb{R}$  itself or intervals, unbounded, closed or open. Therefore, in all cases  $E \supset [x | x \in \mathbb{R}, N < x < M]$  for some constants  $M, N$  with  $M > N$ . With  $f(x) = x$ , we get  $E \supset [x | x \in \mathbb{R}; N < f(x) < M]$ .

We may now suppose that  $E$  is not a convex subset of  $\mathbb{R}$ . As  $0 \in E$ , we either have  $0 < x_1 < x_2$ ,  $x_1 \notin E$ ;  $x_2 \in E$  or  $0 > x_1 > x_2$ ,  $x_1 \notin E$ ;  $x_2 \in E$ . There is no loss of generality (change  $E$  in  $-E$ ) in dealing with the first case only.

Clearly  $x_1$  and  $x_2$  have to be independent over  $\mathbb{Z}$ . Indeed,  $n_1 x_1 + n_2 x_2 = 0$  with  $0 < x_1 < x_2$  leads to  $x_1 = (-n_2/n_1)x_2$  and  $0 \leq -n_2/n_1 \leq 1$ . By Q-convexity,  $(-n_2/n_1)x_1$  has to belong to  $E$  which is a contradiction.

Our first aim is to construct an additive function over  $\varepsilon(x_1, x_2)$ , the subset of  $\mathbb{R}$  of all  $x$  such that  $x = \alpha_1 x_1 + \alpha_2 x_2$  where  $\alpha_1, \alpha_2$  are in  $\mathbb{Q}$ , and bounded over  $E \cap \varepsilon(x_1, x_2)$ . For additivity, first choose  $g(x_1) = r_1$  and  $g(x_2) = r_2$ . This choice should be such that  $g$  remains bounded on  $E \cap \varepsilon(x_1, x_2)$ , that is  $\text{Sup}(\alpha_1 r_1 + \alpha_2 r_2)$  should be finite for all  $\alpha_1, \alpha_2$  in  $\mathbb{Q}$  whenever  $\alpha_1 x_1 + \alpha_2 x_2$  lies in  $E$ .

To show that such a choice is possible, let us first try to write  $x_1$ , which is not in  $E$ , as a Q-convex combination of  $\alpha_1 x_1 + \alpha_2 x_2$  and some rational multiple of  $x_2$ . We easily get

$$x_1 = \frac{\alpha_1 x_1 + \alpha_2 x_2}{\alpha_1} + \left(1 - \frac{1}{\alpha_1}\right) \frac{\alpha_2}{\alpha_1} (-x_2)$$



There arises a contradiction as soon as we really have  $x_1$  as a Q-convex combination of elements in  $E$ . That is for  $\alpha_1 > 1$ ,  $\alpha_1 x_1 + \alpha_2 x_2$  belonging to  $E$ , as well as  $\frac{\alpha_2}{\alpha_1 - 1} x_2$ . In other words, if  $\alpha_1 > 1$  and  $\alpha_1 x_1 + \alpha_2 x_2 \in E$ , then  $\left| \frac{\alpha_2}{\alpha_1 - 1} \right|$  should not be too small because if it is small enough, due to the Q-radiality of  $E$  at the point  $0$ , we obtain that  $-\frac{\alpha_2}{\alpha_1 - 1} x_2 \in E$  (If  $\alpha_2 > 0$ , apply Q-radiality to  $-x_2$  and to  $x_2$  for  $\alpha_2 < 0$ ). We thus define a strictly positive  $\beta$

$$\beta = \text{Inf} \begin{cases} \alpha_1 x_1 + \alpha_2 x_2 \in E \\ \alpha_1 > 1 \quad \alpha_1 \in Q \\ \alpha_2 > 0 \quad \alpha_2 \in Q \end{cases} \left( \frac{\alpha_2}{\alpha_1 - 1} \right) > 0$$

We immediately get for  $\alpha_1 > 1$  and  $\alpha_2 > 0$ ,  $\alpha_1, \alpha_2$  in  $Q$ , and  $\alpha_1 x_1 + \alpha_2 x_2 \in E$

$$(2) \quad \alpha_1 - \frac{\alpha_2}{\beta} \leq 1$$

If we were to take  $g(x_1) = r_1 = 1$  and  $g(x_2) = r_2 = \frac{1}{\beta}$ , it only remains to verify that such an inequality (2) still holds for  $\alpha_1 < 1$ , (or  $\alpha_2 \leq 0$ ), and  $\alpha_1 x_1 + \alpha_2 x_2 \in E$ .

For  $\alpha_2 = 0$ , (2) is obviously true with  $\alpha_1 < 1$  and  $\alpha_1 \geq 1$  is impossible as  $\alpha_1 x_1 \in E$  implies by Q-convexity,  $x_1 \in E$  which is contrary to our hypothesis.

For  $\alpha_1 < 1$  and  $\alpha_2 > 0$ , the inequality (2) is obvious.

For  $\alpha_1 < 1$  and  $\alpha_2 < 0$ , we shall prove the inequality (2) by

way of contradiction. So we suppose there exist  $\alpha_1, \alpha_2$  in  $Q$ , where  $\alpha_1 < 1$ ,  $\alpha_2 < 0$ ,  $\alpha_1 x_1 + \alpha_2 x_2 \in E$  but  $\alpha_1 - \frac{\alpha_2}{\beta} > 1$ . We try in this new case, to express  $x_1$  as some convenient Q-convex combination of  $X$  and  $Y$  in  $E$ . We naturally wish to keep  $X$  as  $\alpha_1 x_1 + \alpha_2 x_2$  and try for some  $Y$  of the form  $\alpha'_1 x_1 + \alpha'_2 x_2$ , where  $\alpha'_1, \alpha'_2$  shall have to be determined in  $Q$  so that  $\alpha'_1 x_1 + \alpha'_2 x_2 \in E$ . To get more freedom, we should work with  $\frac{1}{b} (\alpha_1 x_1 + \alpha_2 x_2)$  and  $\frac{1}{b} (\alpha'_1 x_1 + \alpha'_2 x_2)$  for some  $b \in Q$ ,  $b \geq 1$ . Therefore, we look for some  $a$ ,  $a \in Q$ ,  $0 \leq a \leq 1$  such that

$$x_1 = a \frac{\alpha_1 x_1 + \alpha_2 x_2}{b} + (1-a) \frac{\alpha'_1 x_1 + \alpha'_2 x_2}{b}$$

We get the necessary values for  $a$  and  $b$

$$a = \frac{\alpha'_2}{\alpha'_2 - \alpha_2} \quad \text{and} \quad b = \frac{\alpha'_2 \alpha_1 - \alpha_2 \alpha'_1}{\alpha'_2 - \alpha_2}$$

To obtain  $0 \leq a \leq 1$ , as  $\alpha_2 < 0$ , it is enough to ask for  $\alpha'_2 \geq 0$ . The condition on the lower bound for  $b$ , can now be transformed into  $\alpha'_2 (\alpha_1 - 1) \geq \alpha_2 (\alpha'_1 - 1)$  which, if we suppose  $\alpha'_1 > 1$ , amounts to

$$(3) \quad \frac{\alpha'_2}{\alpha'_1 - 1} \leq \frac{\alpha_2}{\alpha_1 - 1}$$

Our hypothesis was  $\frac{\alpha_2}{\alpha_1 - 1} > \beta$ . Therefore, due to the definition of  $\beta$  as a g.l.b, we may find  $\alpha'_1, \alpha'_2$  in  $Q$ ,  $\alpha'_1 > 1$ ,  $\alpha'_2 > 0$ , satisfying  $\alpha'_1 x_1 + \alpha'_2 x_2 \in E$ , for which (3) is satisfied. There is a contradiction as  $x_1$  appears as a Q-convex combination of elements of  $E$ . Hence (2) is true in this case as well.

For  $\alpha_1 > 1$  and  $\alpha_2 < 0$ , clearly inequality (2) is not satisfied and  $\alpha_1 - \frac{\alpha_2}{\beta} > 1$ . We proceed in the same way as in the case  $\alpha_1 < 1$  and  $\alpha_2 < 0$ . But this time our hypothesis is  $\beta > \frac{\alpha_2}{\alpha_1 - 1}$  and we look for  $\alpha_1' > 1$ ,  $\alpha_2' > 0$ ,  $\alpha_1' \in \mathbb{Q}$ ,  $\alpha_2' \in \mathbb{Q}$ ,  $\alpha_1'x_1 + \alpha_2'x_2 \in E$  for which we have an inequality opposite to (3).

$$(4) \quad \frac{\alpha_2'}{\alpha_1' - 1} \geq \frac{\alpha_2}{\alpha_1 - 1}.$$

As  $\frac{\alpha_2'}{\alpha_1' - 1} \geq \beta > \frac{\alpha_2}{\alpha_1 - 1}$ , we may find  $\alpha_1'$ ,  $\alpha_2'$  as required and get a contradiction, so that the case  $\alpha_1 > 1$ ,  $\alpha_2 < 0$  is not possible.

Finally, we have completed our construction of a  $g: \varepsilon(x_1, x_2) \rightarrow \mathbb{R}$ , which is additive on  $\varepsilon(x_1, x_2)$  and bounded above by 1 on  $\varepsilon(x_1, x_2) \cap E$ . By Theorem 4.2, there exists an additive extension  $f$  of  $g$  to all of  $\mathbb{R}$ , which is still bounded above by 1 on  $E$ .

In other words

$$E \subset [x | x \in \mathbb{R}; f(x) \leq 1]$$

For  $0 < x_1 < x_2$ , we get  $f(x_1) = 1$  and  $f(x_2) = -\frac{1}{\beta} < 0$ . Therefore  $f$  cannot be of the form  $f(x) = ax$  for some  $a$  on  $\mathbb{R}$  and so cannot be continuous (Theorem 1.1).

This ends the proof of Proposition 4.4 as we can now deduce the general case when  $x_0 \neq 0$ . In fact, when  $x_0 \neq 0$ , the set  $E - x_0$  is  $\mathbb{Q}$ -radial at 0,  $\mathbb{Q}$ -convex and non empty. Therefore we may apply what has already been proved and so

$$\text{either } E \supset x_0 + [x | x \in \mathbb{R}; N < f(x) < M] = [x | x \in \mathbb{R}, N' < f(x) < M']$$

where we have used  $N' = N + f(x_0)$ ;  $M' = M + f(x_0)$  and  $f$  is continuous

or  $E \subset x_0 + [x | x \in \mathbb{R}, f(x) \leq M] \subset [x | x \in \mathbb{R}, f(x) \leq M']$  with  $M' = M + f(x_0)$  and  $f$  is discontinuous.

It must be noted that in Proposition 4.4, the two possible cases are mutually exclusive. A set like  $[x | x \in \mathbb{R}; f(x) \leq M]$  for a discontinuous and additive  $f: \mathbb{R} \rightarrow \mathbb{R}$  cannot contain an open and non empty set like  $[x | x \in \mathbb{R}; N < g(x) < M]$  for a continuous and additive  $g$  with  $N < M$  (cf Theorem 1.1).

We use Definition 4.6 of the  $\mathbb{Q}$ -convex hull of a set in order to attack our first converse theorem.

Theorem 4.7 Let  $E$  be a non empty subset of  $\mathbb{R}$ . The two following properties for  $E$  are equivalent.

- (i) Every  $f: \mathbb{R} \rightarrow \mathbb{R}$ , additive and bounded above on  $E$  is continuous.
- (ii) For every subset  $F$  of  $\mathbb{R}$ , containing a Hamel basis, the set  $Q((E+F) \cup (E-F))$  contains a subset of positive Lebesgue measure.

Proof To prove that (i) implies (ii) we shall show that if (ii) is not satisfied, then (i) is not satisfied. We thus suppose that there exists a subset  $F$  of  $\mathbb{R}$ , containing a Hamel basis and such that  $Q((E+F) \cup (E-F))$  contains no subset of positive Lebesgue measure.

We first notice that  $Q((E+F) \cup (E-F))$  is  $\mathbb{Q}$ -radial at any point  $t$  of  $E$  (and  $E \subset Q((E+F) \cup (E-F))$ ). For that, we start from an  $x$  in  $\mathbb{R}$ ,  $x \neq 0$ , and can write

$$x = \alpha_1 x_1 + \dots + \alpha_n x_n$$

where  $\alpha_i > 0$  and  $\alpha_i \in \mathbb{Q}$ ;  $x_1, x_2, \dots, x_n \in F \cup (-F)$ . Such a representation



is always possible as  $F$  contains some Hamel basis for  $\mathbb{R}$ . Therefore, for  $\alpha_0 = \sum_{i=1}^n \alpha_i$ ,  $\alpha_0 > 0$ , we get for  $t$  in  $E$

$$\frac{x}{\alpha_0} + t = \frac{\alpha_1}{\alpha_0} (x_1 + t) + \dots + \frac{\alpha_n}{\alpha_0} (x_n + t)$$

proving that  $\frac{x}{\alpha_0} + t \in Q((E+F) \cup (E-F))$ . But  $t \in E \subset Q((E+F) \cup (E-F))$

and from the  $Q$ -convexity of  $Q((E+F) \cup (E-F))$  we deduce that

$$\alpha \left( \frac{x}{\alpha_0} + t \right) + (1-\alpha)t = \alpha \frac{x}{\alpha_0} + t \in Q((E+F) \cup (E-F))$$

for all  $\alpha$ ,  $0 \leq \alpha \leq 1$ ,  $\alpha \in Q$  and  $x \in \mathbb{R}$ ,  $t \in E$ . This is the  $Q$ -radiality of  $Q((E+F) \cup (E-F))$  at any  $t$  (of  $E$ ). Therefore  $Q((E+F) \cup (E-F))$  is a non empty,  $Q$ -convex and  $Q$ -radial subset of  $\mathbb{R}$ . Proposition 4.4 yields the form of such a set. As it cannot contain, by our hypothesis, a subset of positive Lebesgue measure, it cannot include some subset like  $[x | x \in \mathbb{R}; N < f(x) < M]$  for a continuous additive  $f: \mathbb{R} \rightarrow \mathbb{R}$ . Therefore there exists a discontinuous additive  $f: \mathbb{R} \rightarrow \mathbb{R}$ , and an  $M$  such that

$$E \subset Q((E+F) \cup (E-F)) \subset [x | x \in \mathbb{R}; f(x) \leq M]$$

Thus property (i) is not satisfied.

We now prove in a direct way that Property (ii) implies Property (i). Let  $f: \mathbb{R} \rightarrow \mathbb{R}$  be an additive function, bounded above on  $E$  by some  $M$ . Let  $F = [x | x \in \mathbb{R}; |f(x)| \leq 1]$ . Such a set  $F$  contains a Hamel basis for  $\mathbb{R}$ . To see this, let  $h_0$  be an element of a Hamel basis  $H$ . For some convenient  $\alpha$  in  $Q$ ,  $|f(\alpha h_0)| \leq 1$ . But we

already noted that  $(H \setminus [h_0]) \cup [\alpha h_0]$  is another Hamel basis. As in the proof of Proposition 4.3, we deduce the existence of a Hamel basis  $H$  with  $H \subset F$ .

Moreover  $f$  is bounded above by  $M+1$  on  $(E+F) \cup (E-F)$  as is easily seen. Thus  $f$  is bounded above by  $M+1$  on  $Q((E+F) \cup (E-F))$  which means that  $f$  is bounded above on a set of positive Lebesgue measure. Theorem 1.2 yields the continuity of  $f$  and ends the proof of Theorem 4.7.

Note 1 We could easily replace Property (ii) in Theorem 4.7 by the following analogous property.

(iii) For every subset  $F$  of  $\mathbb{R}$ ,  $Q$ -radial at some point, the  $Q$ -convex hull of  $E - F$  contains an open and non empty convex subset.

A simpler result would be expected if we were to ask for a bilateral boundedness condition. In fact, we thus eliminate the intervention of all subsets  $F$  containing a Hamel basis for  $\mathbb{R}$ .

Theorem 4.8 A non empty subset  $E$  of  $\mathbb{R}$  has the property that any additive  $f: \mathbb{R} \rightarrow \mathbb{R}$ , bounded in absolute value on  $E$ , is continuous on  $\mathbb{R}$ , if and only if the  $Q$ -convex hull of  $E - F$  contains a subset of positive Lebesgue measure.

Proof To prove the sufficiency, let us start with an  $f: \mathbb{R} \rightarrow \mathbb{R}$ , additive and such that  $|f(x)| \leq M$  for all  $x$  in  $E$ . Clearly  $|f(x)| \leq 2M$  on  $E - E$  and by  $f(\alpha x) = \alpha f(x)$  for  $\alpha \in Q$ , the same bound occurs for  $Q(E-E)$  and so for  $f$  on a set of positive Lebesgue measure. Theorem 1.2 yields the continuity of  $f$  on  $\mathbb{R}$ .

We shall prove the necessity by way of contradiction. We thus suppose that  $Q(E-E)$  contains no subset of positive Lebesgue measure but that any additive  $f: \mathbb{R} \rightarrow \mathbb{R}$ , bounded in absolute value on  $E (\neq \emptyset)$ , is continuous. Clearly  $E$  does not reduce to a singleton. Moreover, an additive  $f: \mathbb{R} \rightarrow \mathbb{R}$ , equal to zero on  $E - E$  is constant on  $E$  and so continuous everywhere, which implies that  $f$  is zero everywhere, as  $E$  is not simply a singleton. Proposition 4.3 yields that  $E - E$  contains a Hamel basis  $H$  and so by symmetry contains  $-H$ . The same argument as in Theorem 4.7 proves that  $Q(E-E)$  is  $Q$ -radial at 0. But  $Q(E-E)$ , which is  $Q$ -convex, contains no subset of positive Lebesgue measure. Proposition 4.4 yields a discontinuous additive  $f: \mathbb{R} \rightarrow \mathbb{R}$ , bounded above on  $Q(E-E)$  by some constant  $M$ , and  $M$  can be chosen to be positive. But  $Q(E-E) = -Q(E-E)$  and so as  $f(-x) = -f(x)$ , we deduce that  $|f(x)| \leq M$  on  $Q(E-E)$ . Therefore  $|f(x)| \leq M + |f(x_0)|$  where  $x_0$  is any given point of  $E$ . This is in contradiction with our hypothesis and ends the proof.

Note 2 A subset  $E$  having property (i) of Theorem 4.7 is such that any additive  $f: \mathbb{R} \rightarrow \mathbb{R}$ , bounded in absolute value on  $E$ , is continuous. The converse is not true. Let us consider the following example. Take  $E = [x | x \in \mathbb{R}; f(x) \leq M]$  for some constant  $M$  and some discontinuous additive  $f: \mathbb{R} \rightarrow \mathbb{R}$ . The subset  $E$  is not empty. By definition  $E$  does not possess property (i) of Theorem 4.7. However let  $g: \mathbb{R} \rightarrow \mathbb{R}$  be additive and bounded in absolute value on  $E$ . As  $g(\alpha x) = \alpha g(x)$  and  $\alpha x \in E$  for all  $\alpha$  in some unbounded subset of  $\mathbb{Q}$ ,  $g$  is necessarily zero on  $E$  and so is continuous on  $\mathbb{R}$ . In other words, the fact that

$Q(E-E)$  contains a subset of positive Lebesgue measure does not imply the same thing for  $Q((E+F) \cup (E-F))$  where  $F$  is a subset of  $\mathbb{R}$  containing a Hamel basis.

Note 3 For a given Hamel basis  $H$  and an element  $h$  of  $H$ , the projection along  $h \in H$  is the application  $x \rightarrow \alpha_h$  where  $\alpha_h$  is the rational coefficient (possibly 0) of  $h$  in the unique decomposition of  $x$  as a finite rational combination of elements of  $H$ . When  $E$  is of positive Lebesgue measure, for any Hamel basis  $H$ , and any given element  $h$  of  $H$ , the projection along this element cannot remain bounded in absolute value (or even bounded above). This is an easy consequence of Theorem 4.8 (or Theorem 4.7).

Note 4 It is convenient to state a theorem, less strong than Theorem 4.7 or 4.8, but easier to handle.

Theorem 4.9 Let  $f: \mathbb{R} \rightarrow \mathbb{R}$  be an additive function and  $E$  a non empty subset of  $\mathbb{R}$  on which  $f$  is bounded above. Then  $f(x) = xf(1)$  for all  $x$  in  $\mathbb{R}$  if one of the following conditions (i), (ii) or (iii) is satisfied.

- (i) For some  $n \geq 1$ ,  $nE$  contains a set of positive Lebesgue measure.
- (ii)  $E$  is of second Baire category and there exists a non empty open subset  $\theta$  such that  $\theta \cap E$  is of first Baire category.
- (iii) The subset  $Q(E)$ , or even  $M(E)$ , as defined in Chapter IV §3 (Properties 3 and 4) contains a subset of positive Lebesgue measure. Then, if  $f$  is bounded in absolute value on  $E$ , the following condition (iv) is enough to imply  $f(x) = xf(1)$ .
- (iv)  $M(E) - M(E)$  contains a subset of positive Lebesgue measure.

Conditions (i), (ii), (iii) and (iv) are not necessary conditions.

Proof We shall prove the sufficiency of each condition and show by counterexamples, or uses of Theorems 4.7, 4.8, that each is not a necessary condition.

Condition (i) An additive  $f$ , bounded above on  $E$ , is also bounded above on  $nE$ , for a given  $n$ . Therefore, the sufficiency of (i) comes from Theorem 1.2 or by a direct application of Theorem 4.7.

However, it is interesting to construct an example of a subset  $E$  in which, for all integers  $n$ ,  $nE$  contains no subset of positive Lebesgue measure, but such that every Cauchy solution, bounded from above on  $E$  is continuous. In other words that  $Q((E+F) \cup (E-F))$  contains a subset of positive Lebesgue measure, for all Hamel bases  $F$ , does not imply that for some integer  $n$ ,  $nE$  contains a subset of positive Lebesgue measure (Theorem 4.7). We start from a Hamel basis  $H$  and a given ordering of all rational numbers  $Q = \bigcup_{n=1}^{\infty} [r_n]$  with  $r_1 = 0$ . Take  $E = \bigcup_{n=1}^{\infty} \bigcup_{h \in H} r_n h$ . We first notice that for all  $n \geq 1$ ,  $nE$  contains no subset

of positive Lebesgue measure, due to Proposition 4.1. We may prove  $F(E) = \bigcup_{n=1}^{\infty} nE = \mathbb{R}$  but this result is not enough as shall be seen later

in Note 5. However we may also prove  $M(E) = \mathbb{R}$ . The first result  $F(E) = \mathbb{R}$  is easy by definition of a Hamel basis. For the second,

$M(E) = \mathbb{R}$ , we write any  $x$  in  $\mathbb{R}$  as  $x = x_1 h_1 + \dots + x_n h_n$  where  $x_n \in Q$ ,  $h_n \in H$ . Taking an integer  $j$  such that  $2^{j-1} < n \leq 2^j$ , we get

$$x = \frac{1}{2^j} (2^j x_1 h_1 + \dots + 2^j x_n h_n) = \frac{1}{2^j} (r_{i_1} h_1 + \dots + r_{i_n} h_n)$$

As  $r_1 = 0$ , we may add enough zeroes so that  $x \in \frac{1}{2^j} (2^j E) \subset M(E)$ .

By (iii), which shall be proved soon, any function bounded above on  $E$  and additive, is continuous. This ends our counterexample.

Condition (ii) This is a consequence of Corollary 3.2 along with (i) in case  $n = 2$ .

The Cantor set shows that (ii) is not a necessary condition. However, it should be noticed here that we cannot take  $E$  in (ii) to be just a second Baire category subset. The following is a counterexample. Let  $H$  be a Hamel basis and  $H'$  a non empty, at most countable subset of  $H$ . We have noticed that  $H \setminus H' \neq \emptyset$ . Let  $E$  be  $\epsilon(H \setminus H')$ , the set of all finite rational combinations of elements in  $H \setminus H'$ . Such an  $E$  is a proper sub-group of  $\mathbb{R}$  and we may easily find an additive but discontinuous function, bounded above on  $E$  (Use Theorem 4.6). However  $E$  is of second Baire category as we get  $\mathbb{R} = \bigcup_{\substack{h \in H' \\ r \in Q}} (rh + \epsilon(H \setminus H'))$ , which is

a countable union of subsets  $rh + \epsilon(H \setminus H')$ , the Baire category of which is the same as  $\epsilon(H \setminus H')$ . But a countable union of first Baire category subsets is of first Baire category and on the contrary (Theorem 3.3),  $\mathbb{R}$  is of second Baire category. This ends our counterexample.

Condition (iii) Recall that  $M(E)$  is the union of all  $E_n$ ,  $n \geq 0$ , where  $E_0 = E$ ,  $E_n = \frac{E_{n-1} + E_{n-1}}{2}$  for  $n \geq 1$ . We may immediately notice that

$$M(E) = [x | x \in \mathbb{R}; \quad x = \sum_{i=1}^n \alpha_i x_i \quad x_i \in E, 0 \leq \alpha_i \leq 1 \\ \alpha_i \text{ dyadic and } \sum_{i=1}^n \alpha_i = 1].$$

Dyadic numbers are numbers of the form  $k2^n$  for  $k$  and  $n$  in  $\mathbb{Z}$ . Clearly then  $Q(E) \supset M(E)$ . For any non empty subset  $F$  of  $\mathbb{R}$ , we deduce that

$$Q((E+F) \cup (E-F)) \supset M(E)$$

Theorem 4.7 yields the conclusion.

Let us construct a  $Q$ -convex subset  $E$  of  $\mathbb{R}$  (and therefore  $E = M(E) = Q(E)$ ), containing no subset of positive Lebesgue measure but such that any additive function, bounded above on  $E$ , is in fact continuous. Let  $H$  be a Hamel basis. As a consequence of Hausdorff's maximality theorem, there exists a total (even well-) ordering of  $H$ . For such an order we define  $E$  to be the set of all  $x = \alpha_1 h_{i_1} + \dots + \alpha_n h_{i_n}$  where  $\alpha_1, \alpha_2, \dots, \alpha_n \in Q$ , with  $\alpha_n > 0$ , and where  $h_{i_1} < h_{i_2} < \dots < h_{i_n}$ . Clearly  $E$  is  $Q$ -convex and contains  $H$ . Let us prove by way of contradiction that  $E$  contains no subset of positive Lebesgue measure. If  $E \supset F$ , where  $F$  is of positive Lebesgue measure, then  $E + E \supset F + F$  and so  $E + E$  contains an open interval due to Lemma 1.1. But  $E = E + E$ . Take now  $h \neq h'$  on  $H$  with  $h < h'$  and consider the subset  $G$  of all  $\alpha h - h'$  where  $\alpha$  runs through  $Q$ . By definition,  $G \cap E = \emptyset$ . However,  $G$  is dense in  $\mathbb{R}$ , being the translate of an homothetic image of  $Q$ . As  $E$  contains an open interval we have the contradiction:  $G \cap E \neq \emptyset$ . Now, let  $f: \mathbb{R} \rightarrow \mathbb{R}$

be an additive function, bounded above by  $M$  on  $E$ . Let us consider  $h, h'$  in  $H$  with  $h < h'$ . We must have  $f(\alpha h + h') = \alpha f(h) + f(h') \leq M$  for all  $\alpha$  in  $Q$  as  $\alpha h + h' \in E$  and so deduce that  $f(h) = 0$ . As  $h'$  is arbitrary,  $f(H) = 0$  and consequently  $f \equiv 0$  (Theorem 4.6), which proves that  $f$  is necessarily continuous and ends the discussion of our counterexample.

Condition (iv) As in Condition (iii), we notice that  $M(E) - M(E) \subset Q(E) - Q(E) \subset Q(Q(E) - Q(E))$ . Then we apply Theorem 4.8 to  $Q(E)$  as  $f$ , bounded in absolute value on  $E$ , is also bounded in absolute value in  $Q(E)$ .

To see that (iv) is not a necessary condition, we exhibit an  $E$  for which  $Q(E-E)$  contains a subset of positive Lebesgue measure but  $M(E) - M(E)$  contains no such subset. Let  $H$  be a Hamel basis and  $E$  be the set of all real  $x$  which can be written as a finite linear dyadic combination of elements of  $f$ :

$$x = \sum_{i=1}^n \alpha_i h_i; \quad n \geq 1; \quad h_i \in H; \quad \alpha_i = m_i 2^{n_i} \quad \text{with } m_i, n_i \in \mathbb{Z}.$$

As  $H$  is a Hamel basis, it is not difficult to prove that  $Q(E-E) = \mathbb{R}$ . However  $M(E) = E$  and  $E - E = E$  so that  $M(E) - M(E) = E$ . Let us show that the situation  $E \supset F$ , with  $F$  of positive Lebesgue measure, is impossible. As  $E + E = E \supset F + F$ ,  $E$  would contain a non empty open subset  $\theta$ . Let  $x_0$  be in  $\theta$  and  $h$  a given element of the Hamel basis  $H$ . Let  $p$  be a sufficiently small non dyadic number so that  $x_0 + ph$  too belongs to  $\theta$ . Therefore  $(x_0 + ph) - x_0 \in \theta - \theta \subset E - E = E$ . Because of the uniqueness of the decomposition of  $ph \in E$ , this is a contradiction as  $p$  is not a dyadic number.

Note 5 A necessary condition for a subset  $E$  to imply that all additive

functions  $f: \mathbb{R} \rightarrow \mathbb{R}$ , bounded above on  $E$ , are continuous is  $\epsilon(E) = \mathbb{R}$ . (If  $\epsilon(E) \neq \mathbb{R}$ , there exists a Hamel basis  $H'$  for  $\epsilon(E)$ , because of Definition 4.3. We just have to add elements in  $\mathbb{R} \setminus \epsilon(E)$  to  $H'$ , to get a Hamel basis on  $\mathbb{R}$ . Setting  $f(H') = 0$  and  $f(H \setminus H') = 1$  and extending by additivity (Theorem 4.6), we get an additive and discontinuous  $f$ , equal to 0 on  $E$  and so bounded above on  $E$ ). However  $\epsilon(E) = \mathbb{R}$  is not a sufficient condition. Even  $F(E) = \mathbb{R}$  is not sufficient. For example we can take a Hamel basis  $H$  and  $E$  to be the union of all  $\alpha h$  where  $\alpha \in \mathbb{Q}$ ,  $|\alpha| \leq 1$  and  $h \in H$ . Clearly  $F(E) = \mathbb{R}$  but just take  $f(H) = 1$ , and extend it by additivity to get a counterexample.

Note 6 For Theorems 4.7, 4.8, we made use of Theorem 4.2 so that we cannot easily generalize to a divisible abelian group  $G$ . However it is easy to obtain results for  $f: \mathbb{R} \rightarrow B$  where  $B$  is a real (or complex) normed space.

Corollary 4.8 Let  $B$  be a real (or complex) non trivial normed space.

Let  $E$  be a subset of  $\mathbb{R}$ . We have the equivalent properties

(i) Any additive  $f: \mathbb{R} \rightarrow B$ , such that  $\sup_{x \in E} \|f(x)\|$  is finite, is continuous

(ii)  $Q(E-E)$  contains a subset of positive Lebesgue measure.

Proof We first suppose  $B$  to be a real normed space. Suppose (ii) is true. Let  $x^*$  be an element of the topological dual of  $B$ . The function  $x \rightarrow \langle f(x), x^* \rangle$ , from  $\mathbb{R}$  into  $\mathbb{R}$ , is additive and bounded in absolute value on  $E$ . With the help of Theorem 4.8, using (ii), such a function is continuous, and so has the form  $\langle f(1), x^* \rangle x$ . As a consequence, for any  $\epsilon > 0$ , there exists a  $\eta, \eta > 0$  and  $|x| \leq \eta$

implies  $|\langle f(x), x^* \rangle| \leq \epsilon$  for all  $x^*$  in the unit ball ( $\|x^*\| \leq 1$ ) of the dual  $B^*$  of  $B$ . The discontinuity of  $f$  would then imply its discontinuity at the point 0. Such a discontinuity would mean the existence of an  $\epsilon > 0$  such that for an  $\eta, \eta > 0$ , there exists an  $x, |x| \leq \eta$  and  $\|f(x)\| \geq \epsilon$ . There should exist an  $x^*$  in the dual, depending upon  $x$ ,  $\|x^*\| = 1$  and  $|\langle f(x), x^* \rangle| = \|f(x)\|$ . This last result yields a contradiction and so (i) is also true. Conversely, suppose (i) to be true. Let  $x_0$  be a non zero element of  $B$ . Let  $f: \mathbb{R} \rightarrow \mathbb{R}$  be any additive function, bounded in absolute value on  $E$ . Define  $g: \mathbb{R} \rightarrow B$  according to  $g(x) = f(x)x_0$ . Property (i) implies the continuity of  $g$  and thus the continuity of  $f$ . Theorem 4.8 yields (ii).

As  $C$  is a (2-dimensional) real normed space, we get the same result for  $C$  and then for any complex normed space.



4.5 Numerical additive functions on  $\mathbb{R}^n$ 

We begin with a simple generalization of Theorem 1.2 to  $\mathbb{R}^n$

Theorem 4.10 Let  $f: \mathbb{R}^n \rightarrow \mathbb{R}$  be a solution of the Cauchy equation

$$f(x+y) = f(x) + f(y) \quad \text{for all } x, y \in \mathbb{R}^n,$$

bounded above on a subset  $E$  of positive Lebesgue measure. There exists an

$a = (a_1, a_2, \dots, a_n)$  in  $\mathbb{R}^n$  such that

$$f(x) = \langle x, a \rangle = \sum_{i=1}^n a_i x_i.$$

Proof We may apply the proof of Corollary 3.1 to show that  $E + E$  contains  $\theta$ ,

a non empty open subset of  $\mathbb{R}^n$ , on which  $f$  is bounded above. We may suppose  $\theta \supset \prod_{i=1}^n ]a_i, b_i[$  where  $a_i < b_i$ . By additivity, we deduce that

$$f(x_1, x_2, \dots, x_n) = f_1(x_1) + \dots + f_n(x_n) \quad \text{where } f_i(x_i) = f(0, \dots, x_i, \dots, 0)$$

with  $x_i$  appearing at the  $i$ -th place. As  $f_i: \mathbb{R} \rightarrow \mathbb{R}$  is additive and

bounded above on  $]a_i, b_i[$ ,  $a_i < b_i$ , Theorem 1.1 proves the existence

of an  $a_i$  in  $\mathbb{R}$  such that  $f_i(x_i) = a_i x_i$  for all  $x_i$  in  $\mathbb{R}$ . This

ends the proof of Theorem 4.10. As a consequence, using Corollary 1.1,

we get

Corollary 4.9 Let  $X$  be a convex cone in  $\mathbb{R}^n$  containing a non empty open

subset  $\theta$ . Let  $f: \mathbb{R}^n \rightarrow \mathbb{R}$  be such that for all  $x, y$  in  $X$

$$f(x+y) = f(x) + f(y)$$

and suppose  $f$  is bounded above on  $\theta$ . Then there exists  $a \in \mathbb{R}^n$  such

that for all  $x$  in  $X$ , we get

$$f(x) = \langle a, x \rangle$$

Converse theorems as proved in §4 can easily be generalized to any real linear space of dimension  $n$ , using Definitions 4.1, 4.2 and 4.6. First, we have to generalize Proposition 4.4.

Proposition 4.5 Let  $E$  be a non empty subset of a real linear space  $X$  of dimension  $n$ . Suppose  $n$  is  $Q$ -convex,  $Q$ -radial at some point and contains no subset of positive Lebesgue measure. There exists an additive  $f$  and some constant  $M$  such that  $f: X \rightarrow \mathbb{R}$ ,  $E \subset \{x \mid x \in X; f(x) \leq M\}$ .

As in Proposition 4.4, we may suppose without loss of generality that  $E$  is  $Q$ -radial at the point 0. Let  $(e_i)$ ,  $i = 1, 2, \dots, n$  be a basis for  $X$  and let  $E_i$  be the non empty intersection of  $E$  with the real linear space generated by  $e_i$ . Every  $E_i$  is  $Q$ -convex and  $Q$ -radial at 0. We distinguish between two cases:

- Either for all  $E_i$ ,  $i = 1, \dots, n$ , there exists a continuous and additive  $f_i(x)$ ,  $f_i(x) = c_i x$ ,  $c_i \in \mathbb{R}$  such that  $E_i \supset \{x \in \mathbb{R}; N_i < f_i(x) < M_i\}$  where  $N_i, M_i$  are real constants ( $N_i < M_i$ ).

- Or, for some  $i$ ,  $E_i \subset \{x \in \mathbb{R}; f_i(x) \leq M\}$  for some discontinuous and additive  $f_i: \mathbb{R} \rightarrow \mathbb{R}$  and some constant  $M$ .

In the first case,  $E_i \supset \{x \in \mathbb{R}; b_i < x < a_i, b_i < a_i\}$ . Then let us prove  $E \supset \prod_{i=1}^n ]\frac{a_i e_i}{n}, \frac{b_i e_i}{n}[$ , where  $n$  is the dimension of

$X$ . To see this last point, let  $a_i < nx_i < b_i$  and set  $x = x_1 e_1 + \dots + x_n e_n$ .

We write

$$x = \frac{1}{n} [nx_1 e_1 + \dots + nx_n e_n]$$

and so  $x \in E$  due to the  $Q$ -convexity of  $E$ . Therefore  $E$  contains a subset of positive Lebesgue measure but this is contrary to our hypothesis.

Therefore we only have to consider the second case for which, by Theorem 4.2, there exists an additive  $f: X \rightarrow \mathbb{R}$ , extending to all of  $\mathbb{R}$  the function  $f_i: E_i \rightarrow \mathbb{R}$  in such a way that

$$E \subset \{x \mid x \in X, f(x) \leq M\}.$$

By construction, such a function is discontinuous, which ends the proof of Proposition 4.5.

We now deduce easily Theorems 4.11 and 4.12 as was done for Theorem 4.7 and 4.8 from Proposition 4.4.

Theorem 4.11 Let  $E$  be a non empty subset of a real linear space  $X$  of dimension  $n$ . Every additive function  $f: X \rightarrow \mathbb{R}$ , bounded in absolute value on  $E$ , is continuous if and only if  $Q(E-E)$  contains a subset of positive Lebesgue measure.

Using Corollary 4.8, we may replace the range  $\mathbb{R}$  by a real (or complex) normed space  $B$  for a  $f: X \rightarrow B$ , bounded in norm, without modifying the result of Theorem 4.11.

Theorem 4.12 Let  $E$  be a non empty subset of a real linear space  $X$  of dimension  $n$ . Every additive function  $f: X \rightarrow \mathbb{R}$ , bounded above on  $E$ , is continuous, if and only if for any subset  $F$  containing a Hamel basis  $H$  for  $X$ ,  $Q((E+F) \cup (E-F))$  contains a subset of positive Lebesgue measure.

It is possible to generalize such theorems to additive functions from a divisible abelian group into certain types of ordered groups. To introduce the required properties of such groups would take us outside our intended scope. The same can be said for a generalization of Proposition 4.5 to a Banach space  $X$  (replacing subsets of positive Lebesgue measure by non empty open subsets).

#### 4.6 An application to Jensen convex functions

In Chapter I, §6, we introduced functions  $f: \mathbb{R} \rightarrow \mathbb{R}$  satisfying a Cauchy inequality (1), expecting close relations with Cauchy solutions.

$$(1) \quad f(x+y) \geq f(x) + f(y) \quad \text{for all } x, y \text{ in } \mathbb{R}.$$

Such functions appeared not to have such a close relationship with Cauchy solutions and we look in fact for "nicer" inequalities.

It should be noted that an odd  $f$ , satisfying (1), is additive. ( $f(x-y) \geq f(x) - f(y)$  and therefore  $f(x) = f(x-y+y) \geq f(x-y) + f(y) \geq f(x)$ . This implies for all  $x, y$ ,  $f(x-y) = f(x) - f(y)$  which gives us the Cauchy equation).

If we restrict the domain of  $f$  to the subset  $\mathbb{R}^+ = [0, \infty[$ , an algebraic way to find  $f: [0, \infty[ \rightarrow \mathbb{R}$  satisfying (1) (different from the one given in Chapter I, §6) is to consider all  $f: [0, \infty[ \rightarrow \mathbb{R}$  such that  $f(0) = 0$  and

$$(2) \quad f(\lambda x) \leq \lambda f(x) \quad \text{for all } \lambda, x \in \mathbb{R}^+$$

Such a function  $f$  necessarily satisfies (1) as for  $x, y$  strictly positive, we deduce with  $\lambda = \frac{x}{x+y}$ ,  $f(x) \leq \lambda f(x+y)$  and similarly,  $f(y) \leq (1-\lambda)f(x+y)$ , yielding  $f(x) + f(y) \leq f(x+y)$ . As  $f(0) = 0$ , (1) is true for all  $x, y$  in  $[0, \infty[$ . Clearly (2), and so (1), will be satisfied by a function  $f: [0, \infty[ \rightarrow \mathbb{R}$  such that  $f(0) = 0$  and for every  $\lambda, x \in \mathbb{R}$ ,  $0 \leq \lambda \leq 1$ , and for all  $x, y$  in  $[0, \infty[$

$$(3) \quad f(\lambda x + (1-\lambda)y) \leq \lambda f(x) + (1-\lambda)f(y)$$

Eq (3) is the functional inequality of convexity. Namely, let  $I$  be a convex subset of a real linear space (i.e. a subset for which  $x, y$  in  $I$

implies  $\lambda x + (1-\lambda)y \in I$  for all  $\lambda \in \mathbb{R}$ ,  $0 \leq \lambda \leq 1$ . A function  $f: I \rightarrow \mathbb{R}$  is called convex if for all  $\lambda \in \mathbb{R}$ ,  $0 \leq \lambda \leq 1$  and all  $x, y$  in  $I$ .

$$f(\lambda x + (1-\lambda)y) \leq \lambda f(x) + (1-\lambda)f(y)$$

If  $I = [a, b] \subset \mathbb{R}$  where  $-\infty < a < b < +\infty$ , a convex function is bounded from above since any  $x$  in  $[a, b]$  can be written as  $x = \lambda a + (1-\lambda)b$ ,  $\lambda \in \mathbb{R}$  and  $0 \leq \lambda \leq 1$ . Thus we may compute that  $f(x) \leq \lambda f(a) + (1-\lambda)f(b) \leq \text{Sup}(f(a), f(b))$ . From this, it is possible to deduce that a convex function on  $[a, b] \subset \mathbb{R}$  is necessarily continuous but this will be later easily deduced from our results (Proposition 4.7). As a consequence an additive and discontinuous function  $f: \mathbb{R} \rightarrow \mathbb{R}$  is never convex. Thus (3) cannot be used as a replacement for the Cauchy equation. However, if  $f: \mathbb{R} \rightarrow \mathbb{R}$  is additive, we notice that

$$(4) \quad f(\lambda x + (1-\lambda)y) = \lambda f(x) + (1-\lambda)f(y)$$

for all rational  $\lambda$ , with  $0 \leq \lambda \leq 1$ , and for all  $x, y$  in  $\mathbb{R}$ . (This comes from  $f(\lambda x) = \lambda f(x)$  for additive functions). We could therefore think of considering those  $f: \mathbb{R} \rightarrow \mathbb{R}$  for which

$$(5) \quad f(\lambda x + (1-\lambda)y) \leq \lambda f(x) + (1-\lambda)f(y)$$

for all  $x, y$  in  $\mathbb{R}$ , and all rational  $\lambda$  with  $0 \leq \lambda \leq 1$ . With  $\lambda = \frac{1}{2}$ , (5) becomes for all  $x, y$  in  $\mathbb{R}$

$$f\left(\frac{x+y}{2}\right) \leq \frac{1}{2}(f(x) + f(y))$$

We shall prove that (6) implies (5) (Lemma 4.2). We better state a definition.

Definition 4.7 A function  $f: I \rightarrow \mathbb{R}$  is called a Jensen convex function on  $I$  (where  $I$  is a convex subset of  $\mathbb{R}^n$ ), if for all  $x, y$  in  $I$ , relation (6) holds.

Jensen functions on  $\mathbb{R}^n$ , and additive functions are intimately related as the following Proposition shows:

Proposition 4.6 Let  $E$  be a non empty subset of  $\mathbb{R}^n$ . The following two properties are equivalent.

- (i) Every additive  $f: \mathbb{R}^n \rightarrow \mathbb{R}$ , bounded above on  $E$ , is continuous.
- (ii) Every Jensen convex  $f: \mathbb{R}^n \rightarrow \mathbb{R}$ , bounded above on  $E$ , is continuous.

Proof (ii) implies (i) Let  $f$  be an additive function. We have  $f\left(\frac{x}{2}\right) = \frac{1}{2}f(x)$  and so  $f\left(\frac{x+y}{2}\right) = f\left(\frac{x}{2}\right) + f\left(\frac{y}{2}\right) = \frac{f(x)+f(y)}{2}$ . Therefore an additive function  $f: \mathbb{R} \rightarrow \mathbb{R}$  is a Jensen convex one.

(i) implies (ii) We shall prove that if (ii) is not satisfied, then (i) cannot be satisfied. Thus let  $f: \mathbb{R}^n \rightarrow \mathbb{R}$  be a discontinuous Jensen convex function (that is not continuous at some point of  $\mathbb{R}^n$ ) and bounded above by a constant  $M$  on  $E$ . (It should be noticed here that if a Jensen convex  $f$  is discontinuous at some point, it is discontinuous everywhere, due to the following lemma.

Lemma 4.1 A Jensen convex function  $f: \mathbb{R}^n \rightarrow \mathbb{R}$ , continuous at a point of  $\mathbb{R}^n$ , is continuous everywhere.

A continuous function at a point being bounded above on an open neighbourhood of this point, Lemma 4.1 is a direct consequence of Proposition 4.7, to be proved very soon). Turning back to our proof of Proposition 4.6, we consider the following subset of  $\mathbb{R}^n$ :

$$K = \{x \mid x \in \mathbb{R}^n; f(x) \leq M\}$$



Clearly  $\kappa \supset E \neq \emptyset$ . The proof that  $\kappa$  is a Q-convex subset follows from the following lemma.

**Lemma 4.2** A Jensen convex function  $f: \mathbb{R}^n \rightarrow \mathbb{R}$  satisfies

$$(7) \quad f(\alpha x + (1-\alpha)y) \leq \alpha f(x) + (1-\alpha)f(y)$$

for all  $x, y$  in  $\mathbb{R}^n$  and all rational numbers  $\alpha$  such that  $0 \leq \alpha \leq 1$ .

Eq (7) is true for  $\alpha = \frac{1}{2}$ . Let us now prove that for any integer  $n$

$$(8) \quad f\left(\frac{x_1 + \dots + x_n}{n}\right) \leq \frac{f(x_1) + \dots + f(x_n)}{n}$$

where  $x_1, x_2, \dots, x_n$  are  $n$  points in  $\mathbb{R}^n$ .

Relation (8) is true for  $n = 2$ . By induction, it can be proved to be true for  $n = 2^h$ , where  $h$  is an integer. To simplify notations, we use

$$A_h = \frac{x_1 + \dots + x_{2^{h-1}}}{2^{h-1}} \quad \text{and} \quad B_h = \frac{x_{2^{h-1}+1} + \dots + x_{2^h}}{2^{h-1}}. \quad \text{Then}$$

$$\begin{aligned} f\left(\frac{x_1 + \dots + x_{2^h}}{2^h}\right) &= f\left(\frac{A_h + B_h}{2}\right) \leq \frac{1}{2}(f(A_h) + f(B_h)) \\ &\leq \frac{1}{2}\left(\frac{f(x_1) + \dots + f(x_{2^{h-1}})}{2^{h-1}}\right) + \frac{1}{2}\left(\frac{f(x_{2^{h-1}+1}) + \dots + f(x_{2^h})}{2^{h-1}}\right) \\ &\leq \frac{f(x_1) + \dots + f(x_{2^h})}{2^h} \end{aligned}$$

Now, let  $n$  be any integer. There exists an integer  $h$  such that  $2^{h-1} < n \leq 2^h$ . We use Eq (8) with  $2^h$  and set  $x_{n+1} = \dots = x_{2^h} = \frac{x_1 + \dots + x_n}{n}$

$$\begin{aligned} f\left(\frac{x_1 + \dots + x_{2^h}}{2^h}\right) &= f\left(\frac{1}{2^h}[(x_1 + \dots + x_n) + (2^h - n)\left(\frac{x_1 + \dots + x_n}{n}\right)]\right) \\ &\leq \frac{1}{2^h}(f(x_1) + \dots + f(x_n) + (2^h - n)f\left(\frac{x_1 + \dots + x_n}{n}\right)) \end{aligned}$$

Therefore, we get the desired result (8).

We may now write any  $\alpha$ ,  $\alpha \in \mathbb{Q}$ ,  $0 \leq \alpha \leq 1$ , in the form  $\alpha = \frac{p}{q}$  where  $p \in [0, 1, 2, \dots] = \mathbb{N} \cup [0]$ ,  $q \in \mathbb{N}$  and  $q \geq p$ . Eq (8) with  $x_1 = x_2 = \dots = x_p = x$  and  $x_{p+1} = \dots = x_q = y$  yields precisely (7)

$$f\left(\frac{p}{q}x + \left(1 - \frac{p}{q}\right)y\right) \leq \frac{p}{q}f(x) + \left(1 - \frac{p}{q}\right)f(y)$$

Returning to the proof of Proposition 4.6, we now show that the set  $\kappa$  is Q-radial at any point  $x_0$  such that  $f(x_0) < M$ . Let  $x$  be an arbitrary non zero element of  $\mathbb{R}^n$ . If  $x + x_0 \in \kappa$ , then  $\alpha x_0 + (1-\alpha)(x+x_0)$  also belongs to  $\kappa$  for  $0 \leq \alpha \leq 1$ ,  $\alpha \in \mathbb{Q}$ . Thus  $x_0 + (1-\alpha)x \in \kappa$ .

If  $y = x + x_0 \notin \kappa$ , that is if  $f(y) > M$ , we define an  $\varepsilon > 0$  by  $f(x_0) = M - \varepsilon$  and choose some  $\alpha_0 \in \mathbb{Q}$ ,  $0 \leq \alpha_0 \leq 1$  by

$$\alpha_0 \geq \frac{f(y) - M}{\varepsilon + f(y) - M}. \quad \text{For all } \alpha \in \mathbb{Q}, 1 \geq \alpha \geq \alpha_0, \text{ we get the following inequalities}$$

$$\begin{aligned} f(\alpha x_0 + (1-\alpha)y) &\leq \alpha f(x_0) + (1-\alpha)f(y) = \alpha(M - \varepsilon) + (1-\alpha)f(y) \\ &\leq f(y) - \alpha(\varepsilon + f(y) - M) \leq f(y) - (f(y) - M) \\ &\leq M \end{aligned}$$

Therefore,  $\alpha x_0 + (1-\alpha)y = x_0 + (1-\alpha)x \in \kappa$ . With the consideration of the two cases, we have proved the Q-radiality of  $\kappa$  at  $x_0$ . (It should be noted that it may happen that no  $x_0$  exists for which  $f(x_0) < M$ . In such a case,  $f(x) = M$  for all  $x$  in  $E$  in which case we may enlarge

M in the definition of  $\kappa$  to bring us into the situation considered above). Let us now prove that  $\kappa$  cannot contain a non empty open subset of  $\mathbb{R}^n$ . For this purpose, we just make use of the following generalization of Theorem 1.2.

Proposition 4.7 Let  $f: \mathbb{R}^n \rightarrow \mathbb{R}$  be a Jensen convex function. If  $f$  is bounded above on a subset  $E$  of positive Lebesgue measure of  $\mathbb{R}^n$ , then  $f$  is everywhere continuous.

To begin with, we suppose that  $E$  contains some non empty open subset of  $\mathbb{R}^n$ . Let  $x$  be any point in  $\mathbb{R}^n$ , and let  $\theta$  be a non-empty open subset of  $\mathbb{R}^n$  on which  $f$  is bounded above by  $M$ . Let  $y_0$  be a given element of  $\theta$ . For  $\alpha \in \mathbb{Q}$ ,  $0 < \alpha < 1$ , the set  $x + \alpha(\theta - y_0)$  is an open neighbourhood of  $x$ . We then write for all  $y$  in  $\theta$ :

$$x + \alpha(y - y_0) = (1 - \alpha) \frac{x - \alpha y_0}{1 - \alpha} + \alpha y$$

Eq (7) yields

$$\begin{aligned} f(x + \alpha(y - y_0)) &\leq (1 - \alpha) f\left(\frac{x - \alpha y_0}{1 - \alpha}\right) + \alpha f(y) \\ &\leq (1 - \alpha) f\left(\frac{x - \alpha y_0}{1 - \alpha}\right) + \alpha M \end{aligned}$$

We thus obtain that for any  $x$  in  $\mathbb{R}^n$   $f$  is bounded above on some open neighbourhood of  $x$ . Let  $x_0$  be any given point of  $\mathbb{R}^n$  for which we consider  $g(x) = f(x + x_0) - f(x_0)$ . The function  $g$  is such that  $g(0) = 0$  and is bounded above by  $N$  in some open neighbourhood  $V$  of 0. We may even suppose  $V$  to be symmetric. Moreover,  $g$  is also a Jensen function as

$$\begin{aligned} g\left(\frac{x+y}{2}\right) &= f\left(\frac{(x+x_0) + (y+x_0)}{2}\right) - f(x_0) \\ &\leq \frac{1}{2}f\left(\frac{x+x_0}{2}\right) + \frac{1}{2}f\left(\frac{y+x_0}{2}\right) - f(x_0) \\ &\leq \frac{1}{2}(g(x) + g(y)) \end{aligned}$$

To prove the continuity of  $f$  at  $x_0$ , we just have to prove that of  $g$  at 0. Let us now write  $x \in \frac{1}{n}V$  as a  $\mathbb{Q}$ -convex combination of 0 and  $nx \in V$

$$x = \left(1 - \frac{1}{n}\right)0 + \frac{1}{n}(nx)$$

Eq (8) yields, as  $nx \in V$ ,

$$g(x) \leq \frac{1}{n}g(nx) \leq \frac{1}{n}N$$

To obtain a minorizing inequality, we first write 0 as a  $\mathbb{Q}$ -convex combination of  $x$  and  $-nx$

$$0 = \frac{1}{n+1}(-nx) + \frac{n}{n+1}x$$

Eq (8) yields

$$g(0) = 0 \leq \frac{1}{n+1}g(-nx) + \frac{n}{n+1}g(x) \leq \frac{1}{n+1}N + \frac{n}{n+1}g(x)$$

which yields:  $g(x) \geq -\frac{N}{n}$ .

To summarize, for all  $x$  in  $\frac{1}{n}V$ ,  $|g(x)| \leq \frac{N}{n}$ . If  $x$  converges to 0, we may let  $n$  go to infinity and so  $g(x)$  goes to zero, proving the continuity of  $g$  at zero.

In general,  $E$  being of positive Lebesgue measure,  $E + E$  contains a non empty open subset of  $\mathbb{R}^n$  (Corollary 3.1) and so  $\frac{E+E}{2} \supset \theta$  with  $\theta$

open and non empty. Clearly,  $f$  being bounded above on  $E$  and Jensen convex, is bounded above on  $\frac{E+E}{2}$ , that is on  $\theta$ . This ends the proof of Proposition 4.7.

We are now ready to end the proof of Proposition 4.6. Due to Proposition 4.7 and 4.5, and the fact that  $\kappa$  is non empty,  $Q$ -radial at some point,  $Q$ -convex and contains no subset of positive Lebesgue measure, we conclude that  $\kappa \supset E$  must be included in some subset of  $\mathbb{R}$  on which some discontinuous additive function is bounded from above. We have thus obtained that (i) is not satisfied.

Theorems 4.9, 4.7 and Proposition 4.5 lead to the following theorem.

Theorem 4.13 Let  $f: \mathbb{R}^n \rightarrow \mathbb{R}$  be a Jensen convex function and  $E$  a non empty subset of  $\mathbb{R}^n$  on which  $f$  is bounded above. Suppose  $E$  satisfies one of the following properties (i), (ii), (iii) or (iv).

- (i)  $E$  contains a subset of positive Lebesgue measure
- (ii)  $E$  is a set of second Baire category and there exists a non empty open subset  $\theta$  of  $\mathbb{R}$  such that  $\theta \cap E$  is of first Baire category.
- (iii)  $M(E)$  contains a subset of positive Lebesgue measure.
- (iv) For every subset  $F$  of  $\mathbb{R}^n$  containing a Hamel basis for  $\mathbb{R}^n$ , the set  $Q((E+F) \cup (E-F))$  contains a subset of positive Lebesgue measure.

Then  $f$  is continuous on all of  $\mathbb{R}^n$  and satisfies the convexity condition

$$f(\alpha x + (1-\alpha)y) \leq \alpha f(x) + (1-\alpha)f(y)$$

for all  $\alpha \in \mathbb{R}$ ,  $0 \leq \alpha \leq 1$ , and all  $x, y$  in  $\mathbb{R}^n$ .

Note When dealing with Jensen convex functions, then contrary to what happened with Cauchy solutions, we cannot replace the upper bound for  $f$  on  $E$  by a lower bound.

There exist discontinuous Jensen convex functions which are bounded below on a set of positive Lebesgue measure (see bibliography).

#### 4.7 Other additive functions linked with number theory

An easy but weak generalization of results obtained in §2 reads as follows for the general rectangular type of conditional Cauchy equations:

Proposition 4.8 Let  $F$  be a divisible abelian group and  $G$  an abelian group. Suppose  $X$  is a subset of  $G$  containing a subgroup  $H$  and  $Y$  is a subset of  $G$ , generating  $H$  as a group. Let  $f: G \rightarrow F$  be a  $Z$ -additive function where  $Z = X \times Y$ . There exists an additive  $g: G \rightarrow F$  such that  $g = f$  on  $H$ .

Motivated by Erdős's result (Theorem 3.12), we shall investigate along the line of Proposition 4.8 but looking for  $M$ -quasi redundant conditions, where  $M$  stands for the class of all monotonic  $f: \mathbb{R} \rightarrow \mathbb{R}$ . Recall (Chapter I) that a monotonic additive function  $f: \mathbb{R} \rightarrow \mathbb{R}$  is of the form  $f(x) = \alpha x$  for some  $\alpha \in \mathbb{R}$ .

Theorem 4.14 Let  $\Gamma$  be a subsemi-group of  $\mathbb{R}$ . Condition  $(\Gamma \times \Gamma, \mathbb{R}, \mathbb{R})$  is  $M$ -quasi redundant.

Let  $\Delta = \Gamma - \Gamma = \{z | z = x - y, x \in \Gamma, y \in \Gamma\}$  and define  $g: \Delta \rightarrow \mathbb{R}$  from a monotonic  $(\Gamma \times \Gamma)$ -additive function  $f$  according to:

$$(1) \quad g(z) = f(x) - f(y) \quad z = x - y$$

For this definition to make sense, we must prove that two different representations of  $z$  as difference of elements of  $\Gamma$  provide the same value for  $g$ . If  $z = x - y = x' - y'$ ,  $x, y, x', y'$  in  $\Gamma$ , then  $x + y' = y + x'$  and so  $f(x) + f(y') = f(x+y') = f(y+x') = f(y) + f(x')$  which yields  $g(x-y) = g(x'-y')$

Let  $z, z'$  be in  $\Delta$  and let us compute  $g(z+z')$ .

If  $z = x - y$ ;  $z' = x' - y'$ ,  $z + z' = (x+x') - (y+y')$  then

$$g(z+z') = f(x+x') - f(y+y') = f(x) + f(x') - f(y) - f(y') = g(z) + g(z').$$

Therefore  $g$  is  $(\Delta \times \Delta)$ -additive.

Suppose  $z > z'$ ,  $z, z'$  in  $\Delta$ . We get  $z = x - y > z' = x' - y'$  or  $x + y' > y + x'$ . Thus  $f(x+y') \geq f(y+x')$  as we may suppose  $f$  to be non-decreasing, without loss of generality. Thus we get  $g(z) = f(x) - f(y) \geq g(z') = f(x') - f(y')$  and the function  $g$  is also non-decreasing.

$\Delta$  is a subgroup of  $\mathbb{R}$ , precisely the subgroup generated by  $\Gamma$ . Suppose first that  $\Delta = \mathbb{Z}x_0$  for some  $x_0$  in  $\mathbb{R}$ . Then  $g(nx_0) = ng(x_0)$ . If  $x_0 = 0$ ,  $g(0) = f(0) = 0$  and an additive extension for  $f$  is the function identically equal to 0. If  $x_0 \neq 0$ , then  $g(x) = \alpha x$  for all  $x$  in  $\Delta$  (with  $\alpha = \frac{g(x_0)}{x_0}$ ). Therefore, for some  $x_1$  in  $\Gamma$ , and for all  $x$  in  $\Gamma$ ,  $f(x) = \alpha(x-x_1) + f(x_1) = \alpha x + \beta$ . But  $f$  is  $(\Gamma \times \Gamma)$ -additive, which implies  $2\beta = \beta$  or  $\beta = 0$ . Then, on  $\Gamma$ , and on  $\Gamma + \Gamma$  a fortiori,  $f$  coincides with the restriction of an additive, monotonic function. We have proved the  $M$ -quasi-redundancy of this simple case. Suppose now  $\Delta = \mathbb{Z}x_0 + \mathbb{Z}y_0$ , where  $x_0, y_0$  are strictly positive numbers, independent over  $\mathbb{Z}$ . For  $g$  to be  $(\Delta \times \Delta)$ -additive we must have:

$$g(nx_0 + my_0) = n\alpha_0 + m\beta_0 \quad \text{for all } n, m \text{ in } \mathbb{Z}$$

with  $\alpha_0 = g(x_0)$  and  $\beta_0 = g(y_0)$ . It only remains to use the fact that  $g$  is non-decreasing, which amounts to:

$$nx_0 + my_0 \geq 0 \quad \text{implies} \quad n\alpha_0 + m\beta_0 \geq 0$$

As  $x_0, y_0$  are strictly positive, then  $\alpha_0 \geq 0$  and  $\beta_0 \geq 0$ . But it is easy to check that either  $\alpha_0 = \beta_0 = 0$  and so  $g \equiv 0$  on  $\Delta$  or  $\alpha_0 > 0$  and  $\beta_0 > 0$ . The first case reaches the conclusion of Theorem 4.14. In the second case, let  $\alpha = \alpha_0/x_0 > 0$  and  $\beta = \beta_0/y_0 > 0$ . We get

$$(2) \quad nx_0 + my_0 \geq 0 \quad \text{implies} \quad nx_0 + m\beta \geq 0.$$

First we prove that for any  $a > 0$ , there exists an  $n \in \mathbb{Z}$  and an  $m \in \mathbb{N}$  such that  $0 < nx_0 - my_0 < a$ . By way of contradiction, let  $0 < b = \text{Inf}(nx_0 - my_0)$  where the infimum is taken over all  $n$  in  $\mathbb{Z}$ ,  $m$  in  $\mathbb{N}$ , such that  $nx_0 - my_0 > 0$ . The set of all  $n'x_0 + m'y_0$ ,  $n', m'$  in  $\mathbb{Z}$ , is a subgroup of  $\mathbb{R}$ , which is not reduced to  $\mathbb{Z}x_0$ , as  $x_0$  and  $y_0$  are independent over  $\mathbb{Z}$ . Its closure must then coincide with all of  $\mathbb{R}$ . Let us choose  $\epsilon$  with  $0 < 2\epsilon < b$ . There exists  $n \in \mathbb{Z}$ ,  $m \in \mathbb{N}$  such that we get  $b \leq nx_0 - my_0 < b + \epsilon$  and  $n' \in \mathbb{Z}$ ,  $m' \in \mathbb{Z}$  such that  $\epsilon < n'x_0 + m'y_0 < 2\epsilon$ . But due to our hypothesis  $m'$  must belong to  $\mathbb{N}$ . Thus the number  $z$ , where  $z = (nx_0 - my_0) - (n'x_0 + m'y_0) = (n-n')x_0 - (m+m')y_0$ , is such that  $0 < z < b$  and  $(m+m') \in \mathbb{N}$ . This contradicts the definition of  $b$  and proves our result. Clearly the role played by  $\pm x_0$  and  $\pm y_0$  is symmetric and in the same way we get  $n \in \mathbb{Z}$ ,  $m \in \mathbb{N}$  such that  $0 < nx_0 + my_0 < a$ . Let us now prove that Eq (2) yields  $\beta = y_0$ . Suppose by way of contradiction that  $\beta > y_0$ . There exist  $n \in \mathbb{Z}$ ,  $m \in \mathbb{N}$  such that

$$(3) \quad 0 < nx_0 - my_0 < \beta - y_0$$

which implies

$$0 < nx_0 - (m-1)y_0 < \beta$$

Using Eq (2), and the first inequality in (3) we get  $nx_0 - m\beta \geq 0$ , therefore we deduce that

$$(4) \quad (m-1)\beta < (m-1)y_0$$

We have supposed  $m \geq 1$  and cannot have  $m = 1$  because of the strict inequality in (4). Thus we obtain a contradiction with  $\beta > y_0$ . An analogous contradiction arises if we were to suppose  $\beta < y_0$ , using this time  $nx_0 + my_0$ ,  $n \in \mathbb{Z}$  but  $m \in \mathbb{N}$ . For all  $x$  in  $\Delta$ , we have obtained  $g(x) = \alpha x$  and so for all  $x$  in  $\Gamma$  and some  $\beta$  in  $\mathbb{R}$

$$f(x) = \alpha x + \beta$$

We easily deduce from the  $(\Gamma \times \Gamma)$ -additivity of  $f$  that  $\beta = 0$  and also in this second case we have proved the  $M$ -quasi-redundancy of  $(\Gamma \times \Gamma, \mathbb{R}, \mathbb{R})$ . In the general case of a subgroup  $\Delta$ , we first define  $\Lambda = \{z | z = \frac{x}{n}, x \in \Delta, n \in \mathbb{N}\}$ . Clearly,  $\Lambda$  is the divisible subgroup generated by  $\Gamma$ . We also define

$$h: \Lambda \rightarrow \mathbb{R} \quad \text{according to} \quad h(z) = \frac{g(x)}{n}$$

$h$  is well-defined as  $z = \frac{x}{n} = \frac{y}{m}$ ,  $x, y \in \Delta$ ,  $n, m \in \mathbb{N}$  implies  $mx = ny$  and so  $mg(x) = ng(y)$ . Moreover  $g$  is  $(\Lambda \times \Lambda)$ -additive since with  $z = \frac{x}{n}$ ,  $z' = \frac{y}{m}$ , and  $x, y \in \Delta$ ,  $n, m \in \mathbb{N}$ , we get

$$\begin{aligned} h(z+z') &= h\left(\frac{mx+ny}{mn}\right) = \frac{g(mx+ny)}{mn} = \frac{mg(x)+ng(y)}{mn} \\ &= \frac{g(x)}{n} + \frac{g(y)}{m} = h(z) + h(z') \end{aligned}$$

In the same way,  $h$  is non decreasing as  $g$  is, and extends  $g$  to all of  $\Lambda$ . Let  $[x_i]_{i \in I}$  a Hamel basis for the divisible subgroup  $\Lambda$

(Definition 4.5). Using the second step, with a subgroup generated by two elements of the Hamel basis, we deduce the existence of an  $\alpha \in \mathbb{R}$  such that  $h(x_i) = \alpha x_i$  for all  $i$  in the index set  $I$ . Therefore, for any  $x$  in  $\Lambda$ ,  $h(x) = \alpha x$ . As a consequence  $f(x) = \alpha x + \beta$  for all  $x$  in  $\Gamma$ . But  $(\Gamma \times \Gamma)$ -additivity yields  $\beta = 0$  and therefore the  $M$ -quasi-redundancy of  $(\Gamma \times \Gamma, \mathbb{R}, \mathbb{R})$  which ends the proof of Theorem 4.14. Note 1 Theorem 3.12, and even Theorem 3.13, appears as a special case of Theorem 4.14. Just use  $\Gamma = \log N = [0, \log 2, \log 3, \dots]$  which is a subsemigroup of  $\mathbb{R}$ . It is certainly possible to generalize Theorem 3.12 in the setting of an ordered archimedean group. An important generalization would be to replace the class  $M$  by something applicable to  $\mathbb{R}^2$  for example, in order to get rid of the use of order properties. To achieve such a goal, a still open problem, would be, starting from any subsemigroup  $\Gamma$  of  $\mathbb{R}$ , to determine the maximal class  $C$  of functions such that  $(\Gamma \times \Gamma, \mathbb{R}, \mathbb{R})$  is  $C$ -quasi redundant. Another generalization would be an investigation along the line of Proposition 4.8. In this case the subgroup  $H$  establishes an algebraic kind of dependence between  $X$  and  $Y$ . To study this more thoroughly, it is best to suppose  $X$  to be a semigroup generated by an element  $x_0$  ( $X = x_0\mathbb{N}$ ) and  $Y$  a semigroup also generated by another element  $y_0$  ( $Y = y_0\mathbb{N}$ ). We shall suppose  $x_0 > 0$ ,  $y_0 > 0$ . An  $X \times Y$ -additive function  $f: \mathbb{R} \rightarrow \mathbb{R}$  thus satisfies

$$(5) \quad f(nx_0 + my_0) = f(nx_0) + f(my_0) \quad \text{for all } n, m \text{ in } \mathbb{N}$$

Such an  $X \times Y$ -condition is not quasi-redundant. Let for example  $\phi: \mathbb{R} \rightarrow \mathbb{R}$  be a periodic function of period  $x_0$  such that  $\phi(0) = 0$  and let  $\psi: \mathbb{R} \rightarrow \mathbb{R}$  be a periodic function of period  $y_0$  such that  $\psi(0) = 0$ . Define  $f = \phi + \psi$ . We verify for all  $n, m$  in  $\mathbb{N}$

$$\begin{aligned}
 F(nx_0 + my_0) &= \phi(nx_0 + my_0) + \psi(nx_0 + my_0) = \phi(my_0) + \psi(nx_0) \\
 &= \phi(my_0) + \psi(my_0) + \phi(nx_0) + \psi(nx_0) \\
 &= f(nx_0) + f(my_0)
 \end{aligned}$$

With convenient choices of  $\phi$  and  $\psi$ ,  $f$  is not additive on  $x_0\mathbb{N} + y_0\mathbb{N}$  and thus  $((X \times Y), \mathbb{R}, \mathbb{R})$  is not quasi-redundant. Quasi-redundancy will not be satisfied even for the class of continuous functions, neither for monotonic functions. In this last case, we may find all monotonic  $(X \times Y)$ -additive functions. Let us begin with a simpler result.

Proposition 4.9 Let  $x_0, y_0$  be positive numbers which are supposed to be independent over  $\mathbb{Z}$ . Let  $X = x_0\mathbb{N}$  and  $Y = y_0\mathbb{N}$ . Suppose  $f: \mathbb{R} \rightarrow \mathbb{R}$  is a monotonic function which is  $(X \times Y)$ -additive. Then there exist a real constant  $\alpha$  and two periodic functions

$$\begin{array}{ll}
 \phi: \mathbb{R} \rightarrow \mathbb{R}, & \text{\underline{\phi of period } } x_0 \\
 \psi: \mathbb{R} \rightarrow \mathbb{R}, & \text{\underline{\psi of period } } y_0
 \end{array}$$

and for all  $x$  in  $t(X \times Y)$ :

$$(5) \quad f(x) = \alpha x + \phi(x) + \psi(x)$$

Proof The crucial step is to prove that for such an  $f$ ,  $\lim_{x \rightarrow \infty} \frac{f(x)}{x}$  exists and is finite, where the limit is taken over those  $x$  in  $x_0\mathbb{N} + y_0\mathbb{N}$ .

For each positive integer  $m$ , there exists at least one integer  $m'$  such that

$$mx_0 < m'y_0 < (m+1)x_0$$

Therefore for all positive integers  $n$

$$nx_0 + mx_0 < nx_0 + m'y_0 < nx_0 + (m+1)x_0$$

Without loss of generality, we may suppose  $f$  to be non-decreasing

$$f(nx_0 + mx_0) < f(nx_0) + f(m'y_0) < f(nx_0) + f((m+1)x_0)$$

$$f(nx_0) + f(mx_0) < f(nx_0) + f(m'y_0) = f(nx_0 + m'y_0) < f((n+m+1)x_0)$$

which yields

$$f(nx_0) + f((m-1)x_0) < f((n+m)x_0) < f(nx_0) + f((m+1)x_0)$$

We now apply this inequality with  $n+m, \dots, n+(h-1)m$  instead of  $n$

$$f((n+m)x_0) + f((m-1)x_0) < f((n+2m)x_0) < f((n+m)x_0) + f((m+1)x_0)$$

$$f((n+(h-1)m)x_0) + f((m-1)x_0) < f((n+hm)x_0) < f((n+(h-1)m)x_0) + f((m+1)x_0)$$

Thus by successive cancellations, if we add all inequalities,

$$f(nx_0) + hf((m-1)x_0) < f((n+hm)x_0) < f(nx_0) + hf((m+1)x_0)$$

Let  $N$  be any positive integer and first fix  $m$ . There exists by euclidian division  $h$  and  $n$ ,  $0 \leq n < m$ , such that  $N = hm + n$ .

Therefore

$$\frac{f(nx_0)}{N} + \frac{h}{N} f((m-1)x_0) < \frac{f(Nx_0)}{N} < \frac{f(nx_0)}{N} + \frac{h}{N} f((m+1)x_0)$$

Let  $N$  go to infinity. We use  $\lim_{N \rightarrow \infty} \frac{h}{N} = \frac{1}{m}$ . From the left inequality,

we deduce  $\lim_{N \rightarrow \infty} \frac{f(Nx_0)}{N} \geq \frac{f((m-1)x_0)}{m}$  and from the right inequality,



$\lim_{N \rightarrow \infty} \frac{f(Nx_0)}{N} \leq \frac{f((m+1)x_0)}{m}$ . But letting now  $m$  tend to infinity, we

deduce that

$$\lim_{N \rightarrow \infty} \frac{f(Nx_0)}{N} = \lim_{N \rightarrow \infty} \frac{f(Nx_0)}{N} = \lim_{N \rightarrow \infty} \frac{f(Nx_0)}{N}$$

Let now  $x = nx_0 + my_0 > 0$ . There exists an integer  $N$  and

$$Nx_0 \leq nx_0 + my_0 < (N+1)x_0$$

Thus

$$\frac{f(Nx_0)}{(N+1)} \leq \frac{f(nx_0 + my_0)}{nx_0 + my_0} < \frac{f((N+1)x_0)}{N}$$

Therefore  $\alpha = \lim_{x \rightarrow \infty} \frac{f(x)}{x}$  exists and is finite. We define now

$$(x = nx_0 + my_0)$$

$g(x) = f(x) - \alpha x$  for all  $x$  in  $\mathbb{R}$ . Recall that  $x_0$  and  $y_0$  are

independent over  $\mathbb{Z}$ . It is possible then to define, with much freedom,

a function  $\phi: \mathbb{R} \rightarrow \mathbb{R}$ , of period  $x_0$ ,  $\phi(0) = 0$ ,  $\phi$  coinciding with  $g$  on  $y_0\mathbb{N}$

and such that  $\lim_{x \rightarrow \infty} \frac{\phi(x)}{x} = 0$  (Take  $\phi$  bounded on the subset of points of  $[0, x_0[$

which are not equal to some  $ny_0$ ,  $n \in \mathbb{N}$ , modulo  $x_0$ ). In the same way,

we define a function  $\psi: \mathbb{R} \rightarrow \mathbb{R}$ , of period  $y_0$ ,  $\psi(0) = 0$ , coinciding

with  $g$  on  $x_0\mathbb{N}$  and such that  $\lim_{x \rightarrow \infty} \frac{\psi(x)}{x} = 0$ . Then

$$\begin{aligned} g(nx_0 + my_0) &= g(nx_0) + g(my_0) \\ &= \psi(nx_0) + \phi(my_0) = \psi(nx_0 + my_0) + \phi(nx_0 + my_0) \end{aligned}$$

In other words  $f(x) = \alpha x + \phi(x) + \psi(x)$  for all  $x$  in  $x_0\mathbb{N} + y_0\mathbb{N}$ , that is for all  $x$  in  $t(X \times Y)$  which ends the proof of Proposition 4.9.

To get the general monotonic solution of  $(X \times Y)$ -additivity, we now have to look for more properties of  $\phi$  and  $\psi$ . In fact, let us suppose that  $f: \mathbb{R} \rightarrow \mathbb{R}$  is defined everywhere by Eq (5) where  $\alpha$  is an arbitrary real number and  $\phi, \psi$  possess the properties as described in Proposition 4.9. We already noticed that  $f$  is  $(X \times Y)$ -additive. However, it need not be monotonic in general. A necessary and sufficient condition for  $f$  to be nondecreasing (reverse the inequality for nonincreasing) is the following inequality valid for all  $x, y$  in  $\mathbb{R}$ ,  $x \neq y$

$$-\alpha \leq \frac{\phi(y) - \phi(x)}{y - x} + \frac{\psi(y) - \psi(x)}{y - x}$$

If we were to impose  $\inf_{\substack{x, y \in \mathbb{R} \\ x \neq y}} \frac{\phi(y) - \phi(x)}{y - x} = -\beta$ ;  $\inf_{\substack{x, y \in \mathbb{R} \\ x \neq y}} \frac{\psi(y) - \psi(x)}{y - x} = -\gamma$

and  $\alpha \geq \beta + \gamma$ , then Eq (5) defines a non-decreasing  $(X \times Y)$ -additive function. Those are sufficient conditions. However it so happens that such conditions are also necessary. We just have to be more precise since  $\phi$  and  $\psi$  are arbitrarily chosen and  $X \times Y$ -additivity only says something on  $x_0\mathbb{N} + y_0\mathbb{N}$ . It can be proved that if  $f$  is a monotonic  $(X \times Y)$ -additive function, then  $\phi$  and  $\psi$  are completely determined on  $x_0\mathbb{Z} + y_0\mathbb{N}_0$ , respectively  $x_0\mathbb{N}_0 + y_0\mathbb{Z}$ , with  $\mathbb{N}_0 = \text{Nu}[0]$  and there exist finite  $\beta, \gamma$  such that

$$-\beta = \inf_{\substack{x \neq y \\ x, y \in x_0 \mathbb{Z} + y_0 \mathbb{N}_0}} \frac{\phi(y) - \phi(x)}{y - x}; \quad -\gamma = \inf_{\substack{x \neq y \\ x, y \in x_0 \mathbb{N}_0 + y_0 \mathbb{Z}}} \frac{\psi(y) - \psi(x)}{y - x}.$$

Moreover  $\alpha \geq \beta + \gamma$ . We refer to the bibliography for a proof. However the following section may provide some hints.

#### 4.8 Generalized conditional Cauchy equation of type II

Let  $G, F$  be abelian groups and for an integer  $h \geq 2$ , let  $X_i$  be non empty subsets of  $G$  with  $i = 1, 2, \dots, h$ . We look for  $f: G \rightarrow G$  such that

$$(1) \quad f\left(\sum_{i=1}^h x_i\right) = \sum_{i=1}^h f(x_i)$$

for all  $x_i \in X_i$ .

The rectangular case is for  $h = 2$ . Redundancy of  $(\prod_{i=1}^h X_i, G, F)$  is easily defined but the most interesting definition is that of C-quasi-redundancy:  $(\prod_{i=1}^h X_i, G, F)$  is C-quasi-redundant if for any  $f: G \rightarrow F$ , belonging to a class  $C$  of functions, and satisfying (1), there exists  $g: G \rightarrow F$ , additive and belonging to the class  $C$ , such that for all  $x_i \in X_i$ , we get

$$g\left(\sum_{i=1}^h x_i\right) = f\left(\sum_{i=1}^h x_i\right)$$

We shall only investigate cases like  $X_i = x_{0,i} \mathbb{N}_0$  where  $\mathbb{N}_0 = \mathbb{N} \cup \{0\}$  and for  $G = F = \mathbb{R}$ , with monotonic functions. It can be proved that  $(\prod_{i=1}^h x_{0,i} \mathbb{N}, \mathbb{R}, \mathbb{R})$  or even  $(\prod_{i=1}^h x_{0,i} \mathbb{Z}, \mathbb{R}, \mathbb{R})$  is not quasi-redundant. The

following result is not difficult to achieve (see bibliography) and settle the case of non independent  $x_{0,i}$ 's over  $\mathbb{Z}$  (with the help of Theorem 4.16).

Theorem 4.15 Let  $a_1, a_2, \dots, a_h$  be  $h$  positive integers where  $h \geq 2$ . Suppose this set is relatively prime. Let  $\alpha_i$  be the greatest common divisor of  $(a_1, a_2, \dots, a_{i-1}, a_{i+1}, \dots, a_h)$ . An  $f: \mathbb{R} \rightarrow \mathbb{R}$  is  $(\prod_{i=1}^h a_i \mathbb{N}_0)$ -additive if and only if there exist a real number  $\alpha$ , periodic functions



$\phi_i: \mathbb{R} \rightarrow \mathbb{R}$ , each of period  $\alpha_i$ , with  $\phi_i(0) = 0$  such that for all  $x \in \sum_{i=1}^h a_i N_0$

$$f(x) = \alpha x + \sum_{i=1}^h \phi_i(x)$$

However, if  $h \geq 3$ , in opposition to Proposition 4.9, monotonic solutions to Eq (1) are the usual linear ones on  $\sum_{i=1}^h x_{0,i} N_0$ .

**Theorem 4.16** Let  $x_{0,i}$ ,  $i = 1, 2, \dots, h$ , be  $h$  positive numbers, independent over  $\mathbb{Z}$ . Suppose  $h \geq 3$ . Condition  $(\sum_{i=1}^h x_{0,i} N_0, \mathbb{R}, \mathbb{R})$  is M-quasi-redundant.

**Proof.** Let  $f: \mathbb{R} \rightarrow \mathbb{R}$  be a monotonic solution of Eq (1) where  $X_i = x_{0,i} N_0$  (and  $N_0 = \text{Nu}[0]$ ). Proposition 4.9 yields that  $\alpha = \lim_{x \rightarrow \infty} \frac{f(x)}{x}$  exists and is finite where  $x$  is required to be of the form  $\sum_{i=1}^h x_{0,i} n_i$ ,  $n_i \in N_0$ .

Then we use  $g(x) = f(x) - \alpha x$ . We may suppose that  $f$  is non-decreasing, so that for all  $x \neq y$  in  $\mathbb{R}$ :

$$(2) \quad \frac{g(x) - g(y)}{x - y} \geq -\alpha$$

It is clear that  $g(0) = f(0) = 0$ . Now let  $Z$  be of the form

$$Z = \sum_{i=2}^h t_i x_{0,i} \quad \text{where } t_i \in \mathbb{Z} \text{ for } i = 2, \dots, h$$

and fix  $x_1 \in N_0 x_{0,1}$ . We define for a strictly positive integer  $j$ ,

$$y_i^{(j)} = j x_{0,i} t_i \quad \text{if } t_i \geq 0 \quad \text{or} \quad y_i^{(j)} = -(j-1) x_{0,i} t_i \quad \text{if } t_i < 0$$

and

$$z_i^{(j)} = (j-1) x_{0,i} t_i \quad \text{if } t_i \geq 0 \quad \text{or} \quad z_i^{(j)} = -j x_{0,i} t_i \quad \text{if } t_i < 0$$

We notice that  $y_i^{(j)} - z_i^{(j)} = x_{0,i} t_i$ . Applying (2) with  $x = x_1 + \sum_{i=2}^h y_i^{(j)}$

and  $y = \sum_{i=2}^h z_i^{(j)}$  we get

$$(3) \quad \frac{g(x_1) + \sum_{i=2}^h (g(y_i^{(j)}) - g(z_i^{(j)}))}{x_1 + Z} \geq -\alpha$$

$$\text{But } \sum_{j=1}^n (g(y_i^{(j)}) - g(z_i^{(j)})) = \begin{cases} g(y_i^{(n)}) & \text{if } t_i \geq 0 \\ g(z_i^{(n)}) & \text{if } t_i < 0 \end{cases}$$

We summarize with  $\epsilon_i = +1$  if  $t_i \geq 0$ ,  $\epsilon_i = -1$  if  $t_i < 0$  by

$$\sum_{i=1}^n (g(y_i^{(j)}) - g(z_i^{(j)})) = g(\epsilon_i y_i^{(n)}).$$

We use Eq (3) with  $j = 1, j = 2, \dots, j = n$ , sum those equations and divide by  $n$

$$\frac{g(x_1) + \frac{1}{n} \sum_{i=2}^h g(\epsilon_i y_i^{(n)})}{x_1 + Z} \geq -\alpha$$

But as a consequence of the definition of the function  $g$ , we get

$\lim_{x \rightarrow \infty} \frac{g(x)}{x} = 0$  at least when  $x \in \sum_{i=1}^h x_{0,i} N_0$ . Therefore we also have

$\lim_{n \rightarrow \infty} \frac{1}{n} g(\epsilon_i y_i^{(n)}) = 0$ . We thus obtain

$$(4) \quad \frac{g(x_1)}{x_1 + Z} \geq -\alpha.$$

We shall now use the fact that  $h \geq 3$ . The set of all possible  $Z$  is then dense in  $\mathbb{R}$ . Therefore (4) is valid only if  $g(x_1) = 0$ . But  $x_1$

was arbitrarily chosen in  $x_{0,1}N_0$ . Therefore  $g(x_{0,1}N_0) = 0$ . By the symmetry in the role of the  $x_{0,i}$ 's, we deduce that  $g(\sum_{i=1}^h x_{0,i}N_0) = 0$ .

In other words, for every  $x \in \sum_{i=1}^h x_{0,i}N_0$ , we get

$$f(x) = \frac{\alpha x}{h}$$

This proves the M-quasi-redundancy of  $(\sum_{i=1}^h x_{0,i}N_0, \mathbb{R}, \mathbb{R})$  and ends the proof of Theorem 4.16.

#### 4.9 Application: a characterization of inner product spaces

Let  $E$  be a real normed space of dimension at least 2. We define an orthogonality relation  $\perp$  for two elements  $x$  and  $y$  in  $E$  according to

$$x \perp y \text{ if for all } \lambda \text{ in } \mathbb{R}, \quad ||x+\lambda y|| \geq ||x||$$

The condition of orthogonal additivity for  $f: E \rightarrow \mathbb{R}$  means

$$(1) \quad f(x+y) = f(x) + f(y) \quad \text{for all } x, y \text{ in } E \text{ such that } x \perp y$$

Let  $C(E)$  denote the class of all continuous functions  $f: E \rightarrow \mathbb{R}$ .

Theorem 4.17 Let  $E$  be a real normed space of dimension at least 2.

The norm of  $E$  comes from an inner product if and only if the condition of orthogonal additivity is not  $C(E)$ -redundant.

Proof Suppose  $E$  is an inner-product space, i.e.  $||x||^2 = \langle x, x \rangle$  where  $\langle \cdot, \cdot \rangle$  is an inner product. Suppose  $x \perp y$ , then we deduce that

$$2\lambda \langle x, y \rangle + \lambda^2 ||y||^2 \geq 0 \quad \text{for every } \lambda \text{ in } \mathbb{R}$$

With  $\lambda > 0$  and letting  $\lambda$  tend to zero we get  $\langle x, y \rangle \geq 0$  and with  $\lambda < 0$ , we deduce that  $\langle x, y \rangle \leq 0$ . Therefore  $\langle x, y \rangle = 0$ . Conversely,  $\langle x, y \rangle = 0$  easily implies  $x \perp y$ . In other words our orthogonal relation  $x \perp y$  is the familiar one  $\langle x, y \rangle = 0$ .

Just define  $f(x) = ||x||^2$ . It is a continuous function from  $E$  into  $\mathbb{R}$ . Moreover,  $f$  is orthogonally additive (Pythagora's theorem). As  $f$  is not additive, we conclude that the condition of orthogonal additivity is not  $C(E)$ -redundant. Suppose now the norm of  $E$  does not come from an inner product. We shall prove that the condition of orthogonal additivity is  $C(E)$ -redundant. This will end the proof of Theorem 4.17. We start from  $f: E \rightarrow \mathbb{R}$ ,  $f$  satisfying the condition

of orthogonal additivity. We decompose  $f$  into its even and odd part

$$(2) \quad f(x) = g(x) + h(x) \quad \left\{ \begin{array}{l} g(x) = \frac{f(x)+f(-x)}{2} \\ h(x) = \frac{f(x)-f(-x)}{2} \end{array} \right.$$

If  $x \perp y$ , then  $(-x) \perp (-y)$  and more generally  $(\lambda x) \perp (\mu y)$ ,  $\lambda, \mu$  on  $\mathbb{R}$ . Therefore both  $g$  and  $h$  satisfies the condition of orthogonal additivity and belongs to  $C(E)$ . We shall then prove that  $h$  is additive (and even linear) and that  $g$  is zero identically. A technical lemma will be useful to provide enough orthogonal elements in  $E$  (See bibliography for a proof).

Lemma 4.3 Let  $H$  be a two dimensional subspace of  $E$ . For any  $z$  in  $H$ , there exists a  $z'$  in  $H$  such that  $z \perp z'$ . Moreover, there exists a pair  $x, y$  of elements of  $H$  and both  $x \perp y$ ,  $(x+y) \perp (x-y)$  holds.

a)  $h$  is additive

Let  $H$  be a two dimensional subspace of  $E$ . Lemma 4.3 provides us with two elements  $x, y$  in  $H$  such that  $x \perp y$  and  $(x+y) \perp (x-y)$ . Clearly then  $\lambda(x+y) \perp \lambda(x-y)$  for any  $\lambda \in \mathbb{R}$  and  $\lambda x \perp \lambda y$  as well as the relation  $\lambda x \perp (-\lambda y)$ . By orthogonal additivity, we deduce for  $h$ .

$$(3) \quad \begin{aligned} h(2\lambda x) &= h(\lambda(x+y) + \lambda(x-y)) = h(\lambda(x+y)) + h(\lambda(x-y)) \\ &= h(\lambda x) + h(\lambda y) + h(\lambda x) + h(-\lambda y) \end{aligned}$$

But  $h$  is odd and so for all  $\lambda \in \mathbb{R}$

$$(4) \quad h(2\lambda x) = 2h(\lambda x)$$

And similarly, the same equation holds with  $x$  replaced by  $y$ . From

(4) alone, and the continuity of  $h$ , it is not possible to derive  $h(\lambda x) = \lambda h(x)$  as has been seen in Chapter III §6 (cf Eq (6)). But an inductive way of reasoning is possible. Suppose  $h(p\lambda x) = ph(\lambda x)$  and  $h(p\lambda y) = ph(\lambda y)$  for all integers  $p$ ,  $1 \leq p \leq n-1$ . Then

$$\begin{aligned} h(\lambda nx + \lambda(n-2)y) &= h(\lambda(n-1)(x+y) + \lambda(x-y)) \\ &= h(\lambda(n-1)(x+y)) + h(\lambda(x-y)) \\ &= h(\lambda(n-1)x) + h(\lambda(n-1)y) + h(\lambda x) + h(-\lambda y) \\ &= nh(\lambda x) + (n-2)h(\lambda y) \end{aligned}$$

But

$$\begin{aligned} h(\lambda nx + \lambda(n-2)y) &= h(\lambda nx) + h(\lambda(n-2)y) \\ &= h(\lambda nx) + (n-2)h(\lambda y) \end{aligned}$$

Therefore

$$(5) \quad h(\lambda nx) = nh(\lambda x) \quad \text{and similarly} \quad h(\lambda ny) = nh(\lambda y)$$

With  $\lambda = \frac{1}{n}$ ,  $n$  a positive integer, we deduce that

$$h\left(\frac{x}{n}\right) = \frac{1}{n} h(x)$$

Applying Eq (5) with  $m$ , an arbitrary non zero integer and using also the fact that  $h$  is odd

$$h\left(\frac{m}{n} x\right) = \frac{m}{n} h(x)$$

The continuity of  $h$  on  $E$  immediately yields for all  $\lambda$  in  $\mathbb{R}$

$$(6) \quad h(\lambda x) = \lambda h(x)$$

Similarly, we deduce that

$$(7) \quad h(\mu y) = \mu h(y) \quad \text{for all } \mu \text{ in } \mathbb{R}.$$

Let us now compute  $h(\lambda x + \mu y)$  by orthogonal additivity using (6) and (7)

$$h(\lambda x + \mu y) = h(\lambda x) + h(\mu y) = \lambda h(x) + \mu h(y)$$

Finally,  $h$  is a linear form on the subspace  $H$  which was arbitrarily chosen. In other words  $h$  is linear on  $E$ , therefore additive.

b)  $g$  is identically zero

Let  $H$  be a two dimensional subspace of  $E$  and as previously let  $x, y$  in  $H$  such that  $x \perp y$  and  $(x+y) \perp (x-y)$ . We shall first compute  $g(2\lambda x)$  where  $\lambda \in \mathbb{R}$ . We write

$$\begin{aligned} g(2\lambda x) &= g(\lambda(x+y) + \lambda(x-y)) = g(\lambda(x+y)) + g(\lambda(x-y)) \\ &= 2g(\lambda x) + 2g(\lambda y) \end{aligned}$$

With the symmetry in  $x$  and  $y$ , we get

$$(8) \quad g(2\lambda y) = 2g(\lambda x) + 2g(\lambda y)$$

Therefore, for all  $\lambda$  in  $\mathbb{R}$ , we obtain  $g(2\lambda x) = g(2\lambda y)$  and as  $\lambda$  is arbitrary

$$(9) \quad g(\lambda x) = g(\lambda y)$$

Then (8) yields

$$g(2\lambda x) = 4g(\lambda x)$$

Let us suppose by induction that for integers  $p$ ,  $1 \leq p \leq n-1$ , we get

$$g(p\lambda x) = p^2 g(\lambda y) \quad \text{and} \quad g(p\lambda y) = p^2 g(\lambda y)$$

Then we compute in two different ways

$$\begin{aligned} g(\lambda n x + \lambda(n-2)x) &= g(\lambda(n-1)(x+y) + \lambda(x-y)) \\ &= g(\lambda(n-1)(x+y)) + g(\lambda(x-y)) \\ &= g(\lambda(n-1)x) + g(\lambda(n-1)y) + g(\lambda x) + g(-\lambda y) \end{aligned}$$

By induction, as  $g$  is even

$$\begin{aligned} &= ((n-1)^2 + 1)g(\lambda x) + ((n-1)^2 + 1)g(\lambda y) \\ \text{Due to (9)} \quad &= (2(n-1)^2 + 2)g(\lambda x) \end{aligned}$$

But

$$\begin{aligned} g(\lambda n x + \lambda(n-2)y) &= g(\lambda n x) + (n-2)^2 g(\lambda y) \\ &= g(\lambda n x) + (n-2)^2 g(\lambda x) \end{aligned}$$

Therefore

$$g(\lambda n x) = (2(n-1)^2 + 2 - (n-2)^2)g(\lambda x) = n^2 g(\lambda x)$$

With  $\lambda = \frac{1}{n}$ ,  $n$  a positive integer, we deduce that

$$g\left(\frac{x}{n}\right) = \frac{1}{n^2} g(x)$$

And with any non zero integer  $m$ , using the fact that  $g$  is even

$$g\left(\frac{m}{n} x\right) = \left(\frac{m}{n}\right)^2 g(x)$$

The continuity of  $g$  on  $E$  implies that

$$(10) \quad g(\lambda x) = \lambda^2 g(x)$$

and similarly for  $y$

$$(11) \quad g(\mu y) = \mu^2 g(y)$$

Therefore, let  $\lambda, \mu$  be in  $\mathbb{R}$  and apply orthogonal additivity using (9), (10) and (11)

$$(12) \quad g(\lambda x + \mu y) = (\lambda^2 + \mu^2)g(x)$$

Now let  $x', y'$  be arbitrary elements in the two dimensional subspace  $H$ . There exist real constants  $a, b, c, d$  and  $x' = ax + by; y' = cx + dy$ .

Therefore

$$g(x') + g(y') = (a^2 + b^2 + c^2 + d^2)g(x)$$

And

$$g(x'+y') + g(x'-y') = ((a+c)^2 + (a-c)^2 + (b+d)^2 + (b-d)^2)g(x)$$

This yields

$$g(x'+y') + g(x'-y') = 2(a^2 + b^2 + c^2 + d^2)g(x)$$

Thus

$$(13) \quad g(x'+y') + g(x'-y') = 2(g(x') + g(y'))$$

Suppose that for some  $x' \neq 0, x' \in H, g(x') = 0$ . Eq (12) yields  $g(x) = 0$  and therefore  $g = 0$  on  $H$ . Let  $z'$  be any non zero element of  $E$ , not in  $H$ , and  $H$  be the two dimensional linear subspace generated by  $z'$  and  $x'$ . By the same process, we get  $g(z') = 0$ . Therefore  $g \equiv 0$  on  $E$ , which was to be proved.

We shall have to show now that the situation  $g(x') \neq 0$  for all  $x' \neq 0$  in  $E$  is impossible. As  $g$  is continuous, by possibly changing  $g$  in  $-g$ , we may suppose that  $g: E \rightarrow \mathbb{R}$ , satisfies Eq (13) and is strictly positive for all  $z \neq 0$  in  $E$ . A classical result in functional analysis, which we shall prove later (Lemma 6.2) yields the existence of an inner product  $\langle \cdot, \cdot \rangle$  on the real space  $E$  and  $g(x) = \langle x, x \rangle$ .

Let us now prove that  $\langle x, y \rangle = 0$  is equivalent to  $x \perp y$ .

If  $x \perp y$ , then  $g(x+y) = g(x) + g(y)$ . Therefore  $\langle x+y, x+y \rangle = \langle x, x \rangle + \langle y, y \rangle$  and so  $2\langle x, y \rangle = 0$ , that is  $\langle x, y \rangle = 0$ .

Conversely, suppose  $\langle x, y \rangle = 0$ . If  $x = 0$ , then clearly  $x \perp y$ .

If  $x \neq 0$ , let  $H$  be the two dimensional subspace generated by  $x$  and  $y$ . There exists  $y'$  in  $H$  and  $x \perp y'$ . As already proved,  $\langle x, y' \rangle = 0$ . Thus as  $H$  is two dimensional,  $y'$  and  $y$  are colinear, which implies  $x \perp y$ . From this result it is not difficult to prove that the norm of  $E$  itself comes from an inner product, which contradicts our hypothesis and ends the proof of Theorem 4.17.

It is certainly possible to replace the class  $C(E)$  by some far larger class of functions, using the kind of techniques developed in Chapter IV. It seems plausible, but is an open problem, to show that one may omit all regularity assumptions in Theorem 4.17 to hold when  $E$  is a finite dimensional normed space.

## CHAPTER V

## CONDITIONAL CAUCHY EQUATIONS OF TYPES III, IV AND V

*Programme* This chapter deals with the general solution of conditional Cauchy equations of type III, IV and V. The tools which are used are mainly from algebra.

## 5.1 Mikusinski' functional equation

In 2.2, we saw how a simple problem of geometry led to a functional equation, the so-called Mikusinski functional equation:

$$(1) \quad f(xy) = f(x)f(y); \quad f(xy) \neq 1$$

where  $f: G \rightarrow F$ . The Cauchy equation is only valid for all  $x, y$  in  $G$  for which  $f(xy) \neq 1$ , where  $1$  is the neutral element of  $G$ .

Theorem 5.1 Let  $G$  be a group with no subgroup of index two.

Take  $Z = [(x,y) \in G \times G; f(xy) \neq 1]$  where  $f: G \rightarrow F$  and  $F$  is any group.

Then  $(Z, G, F)$  is redundant.

Proof Let  $f: G \rightarrow F$  be a  $Z$ -multiplicative function, where for the moment  $G$  and  $F$  are arbitrary groups.

a) Let us first prove that the kernel of  $f$ ,  $\text{Ker } f = [x | x \in G; f(x) = 1]$ , is a subgroup of  $G$ . Clearly  $1 \in \text{Ker } f$  (If there exists  $x$  such that  $f(x) \neq 1$ , then  $f(x) = f(x)f(1)$  and so  $f(1) = 1$  in all cases).

Now  $f(xy) = 1$  when  $x, y$  are in  $\text{Ker } f$  (If not,  $f(xy) \neq 1$  implies a contradiction to Equation (1)). If  $x \in \text{Ker } f$ , to suppose  $x^{-1} \notin \text{Ker } f$  would imply  $x^{-2} \notin \text{Ker } f$  as we get the equalities:



$$(2) \quad f(x^{-1}) = f(x^{-2}x) = f(x^{-2})f(x) = f(x^{-2})$$

and as  $f(x^{-2}) \neq 1$ , we get

$$(3) \quad f(x^{-2}) = f(x^{-1})f(x^{-1})$$

But (2) and (3) yield a contradiction as they imply  $f(x^{-1}) = 1$ .

b) Suppose there exists an  $x_0$ , such that  $x_0 \notin \text{Ker } f$ , but  $x_0^2 \in \text{Ker } f$  and  $(f(x_0))^2 \neq 1$ . Then  $f(x)$  is constant outside  $\text{Ker } f$  in  $G$ . To prove this, let us put  $y_0 = f(x_0)$  (with  $y_0 \neq 1$  as  $y_0^2 \neq 1$ ). Let  $x$  be any element of  $G$ , not belonging to  $\text{Ker } f$ . Equation (1) yields as  $x_0^2 \in \text{Ker } f$ ,

$$(4) \quad \begin{aligned} f(x) &= f(x x_0^{-2} x_0^2) = f(x x_0^{-2}) f(x_0^2) \\ &= f(x x_0^{-2}) \end{aligned}$$

Equation (1) yields as well

$$(5) \quad f(x) = f(x x_0^{-1} x_0) = f(x x_0^{-1}) f(x_0)$$

Suppose  $f(x) \neq f(x_0)$ , then  $f(x x_0^{-1}) \neq 1$  and so with (4)

$$\begin{aligned} f(x x_0^{-1}) &= f(x x_0^{-2} x_0) = f(x x_0^{-2}) f(x_0) \\ &= f(x) f(x_0) \end{aligned}$$

Comparing with (5), we get  $y_0^2 = (f(x_0))^2 = 1$  which contradicts our hypothesis. Thus, for every  $x$ , not in  $\text{Ker } f$ ,  $f(x) = f(x_0) = y_0$ .

c)  $\text{Ker } f$  is a normal subgroup of  $G$  of index 2 if there exists an  $x_0$  in  $G$  having the properties as stated in b). Let  $x \in \text{Ker } f$  and  $y \in G$ . Two cases occur according to whether  $y \in \text{Ker } f$  or  $y \notin \text{Ker } f$ .

If  $y \notin \text{Ker } f$ , then  $y^{-1} \notin \text{Ker } f$  (as  $\text{Ker } f$  is a subgroup).

Moreover  $yx \notin \text{Ker } f$  ( $y = yx \cdot x^{-1}$  and so if  $yx \in \text{Ker } f$ , as  $x^{-1}$  belongs to  $\text{Ker } f$  then  $y \in \text{Ker } f$  which is not true). If the product  $xyx^{-1}$  were not in  $\text{Ker } f$ , according to b), we should have  $y_0 = f(yx^{-1})$ , as well as  $f(yx) = f(y^{-1}) = y_0$ . Then Equation (1) yields  $y_0 = f(yx^{-1}) = f(yx) f(y^{-1}) = y_0^2$  contradicting  $y_0 \neq 1$ .

If  $y \in \text{Ker } f$ , then  $xyx^{-1} \in \text{Ker } f$  as  $\text{Ker } f$  is a subgroup.

We have proved that  $\text{Ker } f$  is a normal subgroup of  $G$ . Now let  $x, y$  be two elements not in  $\text{Ker } f$ . If  $xy^{-1}$  were not in  $\text{Ker } f$  then we should get  $f(xy^{-1}) = y_0$  as well as  $f(x) = f(y^{-1}) = y_0$  and (1) yields the contradiction. Thus  $xy^{-1} \in \text{Ker } f$ . This proves that there are at most two elements in the quotient group  $G/\text{Ker } f$ . But as  $x_0 \notin \text{Ker } f$ , we may claim that there are precisely two elements in  $G/\text{Ker } f$ , i.e.  $\text{Ker } f$  is of index 2.

d) If  $G$  has no normal subgroup of order 2, as supposed in Theorem 5.1, then there cannot exist an  $x_0$  with the properties as stated in b).

Thus for any  $x \notin \text{Ker } f$  with  $x^2 \in \text{Ker } f$ , we get  $(f(x))^2 = 1$ .

Now let us prove for all  $x$  in  $G$ ,  $f(x^2) = (f(x))^2$ . It is clearly true if  $x \in \text{Ker } f$  as  $\text{Ker } f$  is a group. If  $x \notin \text{Ker } f$ , and  $x^2 \notin \text{Ker } f$  then (1) provides us precisely with  $f(x^2) = (f(x))^2$ . If  $x \notin \text{Ker } f$  and  $x^2 \in \text{Ker } f$ , we have proved  $(f(x))^2 = 1$  which is precisely  $1 = f(x^2)$ .

Let us also prove for all  $x$  in  $G$  that  $f(x^{-1}) = (f(x))^{-1}$ . It is clearly true if  $x \in \text{Ker } f$  as  $\text{Ker } f$  is a group. If  $x \notin \text{Ker } f$ , then with equation (1)

$$f(x) = f(x^2 x^{-1}) = f(x^2) f(x^{-1}) = (f(x))^2 f(x^{-1})$$

yielding  $(f(x))^{-1} = f(x^{-1})$ .

We are now ready for the end of the proof of Theorem 5.1. Take two arbitrary elements  $x, y$  in  $G$ .

First suppose  $y \notin \text{Ker } f$ , then Equation (1) yields

$$f(y) = f(x^{-1})f(xy) = (f(x))^{-1}f(xy) \text{ or}$$

$$f(xy) = f(x)f(y)$$

Second, suppose  $x \notin \text{Ker } f$ , Equation (1) also gives  $f(x) = f(xy)f(y^{-1}) = f(xy)(f(y))^{-1}$  and thus

$$f(xy) = f(x)f(y).$$

Finally, if  $x$  and  $y$  are in  $\text{Ker } f$ , so is  $xy$  and we also get

$$f(xy) = f(x)f(y)$$

This ends the proof of the redundancy in Theorem 5.1.

Corollary 5.1 Let  $G$  be a group such that every element of  $G$  is a square. Then for any  $F$ , condition  $(Z, G, F)$  is redundant where  $Z = [(x, y) \in G \times G; f(xy) \neq 1]$ .

The proof amounts to showing that  $G$  has no normal subgroup of index 2. Suppose  $H$  is such a subgroup. Let  $x$  be in  $G$ . If  $x \in H$ , then  $x^2 \in H$ . If  $x \notin H$ , then  $x^2 \in H$  as  $H$  is of index 2. But as every element of  $G$  is a square, we deduce that  $H$  is in fact all of  $G$ . This contradicts the fact that  $G/H$  has precisely two elements. The proof of Theorem 5.1 leads us, without too much effort, to the general solution of Equation (1) when  $G$  possesses subgroups of index 2.

Theorem 5.2 Suppose  $G$  has a subgroup of index 2 and let  $Z$  be  $Z = \{(x, y) | (x, y) \in G \times G; f(xy) \neq 1\}$ . Then for any  $F$  possessing an element  $y_0$  such that  $y_0^2 \neq 1$ , condition  $(Z, G, F)$  is not redundant.

In this case, the non-multiplicative solutions of Equation (1) are of the form

$$(6) \quad f(x) = \begin{cases} 1 & \text{for } x \in H \\ y_0 & \text{for } x \notin H \end{cases}$$

where  $H$  is an arbitrary subgroup of index 2 in  $G$  and  $y_0$  is an arbitrary element of  $F$  having the property that  $y_0^2 \neq 1$ .

Proof Choose a subgroup  $H$  of  $G$ , having an index equal to 2 and suppose  $y_0^2 \neq 1$  where  $y_0$  is in  $F$ . Let us prove that a function, defined as in (6), always satisfies Equation (1).

Take  $x$  and  $y$  in  $G$  such that  $xy \notin H$ . Then we must have either  $x \in H, y \notin H$  or  $x \notin H$  and  $y \in H$  (as  $x \in H, y \in H$  imply  $xy \in H$  for  $H$  is a subgroup and  $x \notin H, y \notin H$  imply  $xy \in H$  because  $H$  is of index 2).

If  $x \in H, y \notin H$ , we get  $y_0 = f(xy) = f(x)f(y) = y_0$ .

If  $x \notin H, y \in H$ , we too get  $y_0 = f(xy) = f(x)f(y) = y_0$ .

However a function defined by Equation (6) is not multiplicative since for  $x$  and  $y$ , both not belonging to  $H$ , we get  $xy$  in  $H$  and so

$$1 = f(xy) \neq f(x)f(y) = y_0^2$$

Due to what has been proved in b) during the study of Theorem 5.1, this ends the proof of Theorem 5.2. This proof may lead easily to other cases of redundancy by disproving the existence of such an element  $y_0$ .



Proposition 5.1 Let  $F$  be a group such that  $y^2 = 1$  for every  $y$  in  $F$ . For any group  $G$ , with  $Z = [(x,y) | (x,y) \in G \times G; f(xy) \neq 1]$ , condition  $(Z,G,F)$  is redundant.

In such a case, a function as defined by Eq (6) still is a multiplicative function.

We may now state a corollary. We begin with the result needed in Chapter 2, §4 and we return to additive notations. Corollary 5.1 yields

Corollary 5.2 A function  $f: \mathbb{R} \rightarrow \mathbb{R}$  continuous at a point and satisfying Equation (1)

$$(1) \quad f(x+y) = f(x) + f(y) \quad \text{for} \quad f(x+y) \neq 0$$

is of the form  $f(x) = f(1)x$  for all  $x$  in  $\mathbb{R}$ .

The conclusion of Corollary 5.2 remains valid if we replace everywhere  $\mathbb{R}$  by  $\mathbb{Q}$ , the subgroup of rational numbers without the continuity assumption on  $f$ .

Example 1 Take  $F = G = \mathbb{Z}$ , the additive group of integers. All non additive solutions of Equation (1)

$$(1) \quad f(n+m) = f(n) + f(m) \quad \text{for} \quad f(n+m) \neq 0$$

are of the form

$$f(n) = \begin{cases} 0 & \text{if } n \text{ is even} \\ n_0 & \text{if } n \text{ is odd where } n_0 \text{ is a} \\ & \text{given integer different from 0.} \end{cases}$$

(The only subgroup of order 2 of  $\mathbb{Z}$  is  $2\mathbb{Z}$ ).

Example 2 Let  $G$  be the multiplicative group of the four matrices

$$e_0 = \begin{bmatrix} 1 & 0 \\ 0 & 1 \end{bmatrix}; \quad e_1 = \begin{bmatrix} -1 & 0 \\ 0 & 1 \end{bmatrix}; \quad e_2 = \begin{bmatrix} 1 & 0 \\ 0 & -1 \end{bmatrix} \quad \text{and} \quad e_3 = \begin{bmatrix} -1 & 0 \\ 0 & -1 \end{bmatrix}$$

Let  $F$  be the additive group  $\mathbb{R}$  of real numbers. There are three distinct subgroups of index 2 in the abelian group  $G$ : the one generated by  $e_1$ , the one generated by  $e_2$  and the one generated by  $e_3$  (as  $e_1^2 = e_2^2 = e_3^2 = e_0$ ,  $e_1e_2 = e_2e_1 = e_3$  and similar relations by permutation).

However a function  $f: G \rightarrow \mathbb{R}$  satisfying the Cauchy equation

$$f(xy) = f(x) + f(y)$$

is identically zero as  $f(e_0) = 0$  and so for example  $f(e_1^2) = f(e_0) = 0 = f(e_1) \dots$ .

The only solutions of the conditional Cauchy equation

$$(1) \quad f(xy) = f(x) + f(y) \quad \text{if} \quad f(xy) \neq 0$$

for  $f: G \rightarrow \mathbb{R}$  are the following ones. (aside from the identically zero function):

$$f(x) = \begin{cases} 0 & \text{for } x = e_0 \text{ and } x = e_1 \\ \alpha & \text{for } x = e_2 \text{ and } x = e_3 \end{cases} \quad 0 \neq \alpha \in \mathbb{R}$$

and the two other solutions which can be obtained by permutation.

Now all the solutions of the conditional Cauchy equation,

$F: \mathbb{R} \rightarrow G$

$$(1) \quad f(x+y) = f(x)f(y) \quad \text{if} \quad f(x+y) \neq 0$$

are the Cauchy ones (Proposition 5.1).

$$f(x+y) = f(x)f(y)$$

As  $f(2x) = (f(x))^2 = e_0$  for all  $x$  in  $\mathbb{R}$ , this means that the conditional Cauchy equation (1) has only the trivial solution  $f(x) \equiv e_0$ . The proof of Theorem 5.1 relies on a detailed study of the properties of the kernel of  $f$ . The present chapter will deal precisely with various properties of the kernel of  $f$ . For example, we may use some topological properties in order to prescribe the size of the kernel of  $f$  so that redundancy is established. A nice result is as follows.

Theorem 5.3 Let  $G$  be a locally compact topological group or a complete metrizable topological group. Suppose that the kernel of  $f: G \rightarrow F$  is a first Baire category subset of  $G$  and define

$$Z = \{(x,y) \mid (x,y) \in G \times G; f(x \cdot y) \neq 1\}.$$

Then, for any group  $F$ , condition  $(Z,G,F)$  is redundant. Let  $f: G \rightarrow F$  be a  $Z$ -multiplicative function. Suppose first that an  $x_0 \in G$  exists having the properties as stated in b) during the proof of Theorem 5.1. Then,  $\text{Ker } f$  is a normal subgroup of index 2. The complement of  $\text{Ker } f$  is a translate of  $\text{Ker } f$  and is thus also of first Baire category. Then  $G$  would be of first category which contradicts Baire's theorem (cf Theorem 3.3, Chapter III). As a consequence, there exists no such  $x_0$ . Following the proof of Theorem 5.1 we deduce then that  $f: G \rightarrow F$  is in fact multiplicative and so condition  $(Z,G,F)$  is redundant. In the same manner, we obtain:

Theorem 5.4 Let  $G$  be a locally compact abelian topological group. Suppose that the kernel of  $f: G \rightarrow F$  is of zero Haar measure. Define

$$Z = \{(x,y) \mid (x,y) \in G \times G; f(xy) \neq 1\}.$$

Then, for any group  $F$ , condition  $(Z,G,F)$  is redundant.

## 5.2 Generalizations of Mikusinski functional equation

A first generalization deals with a slightly more complicated form for the conditional subset  $Z$ . But we shall restrict ourselves to commutative cases. Our first result utilizes a condition on the algebraic size of the kernel of  $f$ .

Theorem 5.5 Let  $F$  be a commutative integral domain of characteristic zero and  $G$  be an abelian group. We take

$$Z = \{(x,y) \mid (x,y) \in G \times G; f(x+y) - af(x) - bf(y) \neq 0\}$$

where  $a$  and  $b$  are given elements of  $F$  such that  $a + b \neq 1$ . Suppose that the kernel of  $f$  has an infinite index. Then  $(Z,G,F)$  is redundant.

Proof 1) As  $F$  is equipped with a multiplication, our conditional functional equation amounts to

$$(1) \quad (f(x+y) - af(x) - bf(y))(f(x+y) - f(x) - f(y)) = 0.$$

If  $f$  is a constant,  $f(x) \equiv c$ , then we get  $a + b = 1$  if  $c \neq 0$  and so every constant is a solution of the conditional equation without being a Cauchy solution. We avoid non zero constants by imposing  $a + b \neq 1$ .

2) We shall first prove that  $\text{Ker } f$  is a subgroup of  $G$ . If  $x, y$  are in  $\text{Ker } f$ , then (1) yields  $(f(x+y))^2 = 0$ , that is  $x + y \in \text{Ker } f$ .

$0 \in \text{Ker } f$  (because  $(1 - (a+b))(f(0))^2 = 0$  and  $a + b \neq 1$ )

Let  $x \in \text{Ker } f$ . Let  $y = -x$  in (1). We get  $b(f(-x))^2 = 0$ .

In a similar way, we get  $a(f(-x))^2 = 0$ . Thus we deduce that  $a = b = 0$  or  $-x \in \text{Ker } f$ . For  $a \neq 0$  or  $b \neq 0$ , this ends the proof that  $\text{Ker } f$  is

a subgroup. The case  $a = b = 0$  is precisely the Mikusinski equation for which we already proved in a) of Theorem 5.1 that  $\text{Ker } f$  is a subgroup.

3) If  $f$  is not odd, then  $a + b = 0$ . Suppose there exists  $x_0$ , and  $f(-x_0) + f(x_0) \neq 0$ . Using Equation (1) with  $x = x_0, y = -x_0$ , then  $x = -x_0, y = x_0$  we get

$$af(x_0) + bf(-x_0) = 0$$

$$\text{and } af(-x_0) + bf(x_0) = 0$$

thus  $(a+b)[f(x_0) + f(-x_0)] = 0$  and so  $a + b = 0$ .

4) If  $a + b = 0$ , then Equation (1) reduces to Mikusinski equation. Writing Equation (1) switching  $x$  with  $y$  and adding it to the original one, we obtain using  $a + b = 0$

$$2f(x+y)(f(x+y) - f(x) - f(y)) = 0.$$

Now if  $a + b = 0$ , with  $\text{ker } f$  having an infinite index, the proof of Theorem 5.1 yields that  $f$  is additive. We may now restrict ourselves to the case  $a + b \neq 0$ .

5) We may now assume that  $f$  is odd,  $a + b \neq 0$  and shall suppose first that  $a \neq b$ . Write Equation (1), switching  $x$  with  $y$  and subtract the two equations:

$$(b-a)(f(x) - f(y))(f(x+y) - f(x) - f(y)) = 0$$

which yields

$$(2) \quad f(x) \neq f(y) \text{ implies } f(x+y) = f(x) + f(y)$$

From now on, we shall no longer use  $a \neq b$  but only Equation (2). Let us prove that the largest subsets of  $G$  on which  $f$  is constant are precisely the cosets of  $\text{Ker } f$ .

If  $x - y \in \text{Ker } f, x = y + z$  where  $z \in \text{Ker } f$ . Equation (1) written for  $x$  and  $y$  is

$$(f(y+z) - f(y))(f(y+z) - af(y)) = 0$$

Thus, if  $y \in \text{Ker } f, y + z \in \text{Ker } f$  and so  $x \in \text{Ker } f$ , in particular  $f(x) = f(y)$ . If  $y \notin \text{Ker } f$ , as  $f(y) \neq f(z)$ , we get the equations  $f(x) = f(y+z) = f(y) + f(z) = f(y)$  and so we also get  $f(x) = f(y)$ .

Now, conversely, take  $x, y$  in  $G$  such that  $f(x) = f(y) \neq 0$ . As  $F$  is a field of characteristic zero,  $f(x) \neq f(-y) = -f(y)$ , we deduce that  $f(x-y) = f(x) - f(y) = 0$ , that is  $x - y \in \text{Ker } f$ , and so  $x$  and  $y$  are in the same coset of  $\text{Ker } f$ .

With the help of Equation (2), to prove that Equation (1) implies the Cauchy equation, it only remains to show that when  $f(x) = f(y)$ , we also get  $f(x+y) = f(x) + f(y)$ . Such a result is true when we add  $f(x) = f(y) = 0$  as  $\text{Ker } f$  is a subgroup. Now if  $f(x) = f(y) \neq 0$ , as  $\text{Ker } f$  is of infinite index, and with what we have already proved, there exists an element  $z, z \notin \text{Ker } f$ , such that both

$$f(z) \neq f(x) \text{ and } f(z) \neq f(-x) = -f(x)$$

Thus

$$f(z+x) = f(z) + f(x) \quad \text{as } f(z) \neq f(x)$$

and

$$f(y-z) = f(y) - f(z) \quad \text{as } f(-z) \neq f(y)$$

But  $f(z+x) - f(y-z) = f(x) - f(y) + 2f(z) = 2f(z) \neq 0$  (as  $z \notin \text{Ker } f$ )

Thus we may apply Equation (2)

$$\begin{aligned} f(x+y) &= f(z+x+y-z) = f(z+x) + f(y-z) \\ &= f(z) + f(x) + f(y) - f(z) \\ &= f(x) + f(y). \end{aligned}$$

6) To end with the proof of Theorem 5.5, we have to deal with the case where  $a = b \neq 0$ . If  $a = b = 1$ , then we plainly get the Cauchy equation. If we assume  $a = b$ , but different from 0 or 1, we still know that  $f$  must be an odd function. We shall prove that Equation (2) remains valid. Suppose by way of contradiction, that there exist  $x_0, y_0$  with  $f(x_0) \neq f(y_0)$  and  $f(x_0+y_0) \neq f(x_0) + f(y_0)$ . Then Equation (1) yields

$$(3) \quad f(x_0+y_0) = af(x_0) + f(y_0)$$

Let us compute  $f(x_0)$ , which we write as  $f(x_0+y_0-y_0)$ . We apply Equation (1) as  $f(x_0+y_0) \neq f(x_0) + f(y_0)$  and with  $f$  being odd, we deduce that

$$(4) \quad f(x_0) = a(f(x_0+y_0) - f(y_0))$$

We eliminate  $f(x_0+y_0)$  in Equation (3) and (4) to get

$$(a-1)[a+1]f(x_0) + af(y_0) = 0$$

and by symmetry in  $x_0$  and  $y_0$ , using  $a \neq 1$ , we obtain

$$(a+1)f(y_0) + af(x_0) = 0$$

Thus, by subtraction, we deduce that

$$f(y_0) = f(x_0)$$

But this is a contradiction to our hypothesis. Therefore we have proved Equation (2) to be valid.

$$(2) \quad f(x) \neq f(y) \text{ implies } f(x+y) = f(x) + f(y)$$

We may now end as in 5) and thus have completed proving Theorem 5.5.

Note 1 If  $a = b = 1$ , Eq (1) amounts to

$$(5) \quad (f(x+y))^2 = (f(x)+f(y))^2$$

With  $G$  as a semi-group and  $F = \mathbb{R}$  or  $F = \mathbb{C}$ , such an equation for  $f: G \rightarrow F$  was already solved in Chapter II §5 (Corollary 2.1) and proved to be equivalent to the Cauchy equation.

More can be said about Eq (5) than the results as available in Theorem 5.5, by relaxing properties of  $F$  and  $G$ .

Theorem 5.6 Let  $G$  be a group, or even a semi-group. Let  $F$  be an integral domain of characteristic different from 3. Then Eq (5) is equivalent to the Cauchy equation.

When  $F$  is a commutative ring without divisors of zero, then Eq (5) is equivalent to the Conditional Cauchy equation relative to  $Z$  where

$$(6) \quad Z = [(x,y) | x \in G; y \in G; f(x+y) + f(x) + f(y) \neq 0].$$

Sometimes such a conditional Cauchy equation is called an alternative equation. With a  $Z$ -additive function ( $Z$  being defined as in (6)), we no longer have to restrict ourselves to rings for  $F$  but can use a semi-group as well. The following theorem is available.

Theorem 5.7 Let  $G$  be a group (or even a semi group). Let  $F$  be a group containing no element of order 3. Moreover, suppose  $F$  is abelian or contains no element of order 4, then Condition  $(Z,G,F)$ , with  $Z$  as defined in (6), is redundant.

Theorem 5.6 is a consequence of Theorem 5.7 as under the assumption made in Theorem 5.6, Eq (5) is equivalent to  $Z$ -additivity. It is possible to give the general solution of  $Z$ -additivity when  $F$  is

an abelian group. If  $F$  has enough elements of order 3 and order 2, then  $(Z, G, F)$  is not redundant. More precisely (See bibliography).

Proposition 5.2 Let  $F, G$  be groups and suppose  $F$  is abelian. A function  $f: G \rightarrow F$  is  $Z$ -additive if and only if  $f$  is either additive or of the following form

$$f(x) = \alpha + g(x)$$

where  $\alpha$  is an element of order 3 in  $F$  and  $g$  an additive function from  $G$  into the subgroup of all elements  $y$  of  $F$  such that  $2y = 0$ .

Proof of Theorem 5.7 To begin with, suppose there exists an  $x_0 \in G$  such that  $2f(x_0) \neq f(2x_0)$ . We use additive notations for both  $G$  and  $F$ . Define  $\alpha_0 = f(x_0)$ , where  $f$  is a  $Z$ -additive function ( $Z$  as in Eq (6)). By  $Z$ -additivity,  $f(2x_0) = -2\alpha_0$ . We compute  $f(3x_0)$  and then  $f(4x_0)$  in two ways

$$f(3x_0) = f(2x_0 + x_0) = \epsilon(f(2x_0) + f(x_0)) = -\epsilon\alpha_0$$

where  $\epsilon$  is either equal to 1 or to -1.

$$f(4x_0) = f(3x_0 + x_0) = \epsilon'(f(3x_0) + f(x_0)) = \epsilon'(-\epsilon + 1)\alpha_0 \quad \epsilon' = \pm 1$$

and

$$f(4x_0) = f(2x_0 + 2x_0) = -4\epsilon''\alpha_0 \quad \epsilon'' = \pm 1$$

Therefore  $(\epsilon'(-\epsilon + 1) + 4\epsilon'')\alpha_0 = 0$

The possible values of the coefficient are  $\pm 2, \pm 4$  and  $\pm 6$ . But  $4\alpha_0 = 0$  is impossible as it implies  $f(2x_0) = -2\alpha_0 = +2\alpha_0 = 2f(x_0)$ . A fortiori  $2\alpha_0 = 0$  is impossible. Therefore  $6\alpha_0 = 0$ . But  $2\alpha_0$  would be an element of order exactly 3, which is impossible by the hypothesis. We deduce that

for all  $x$  in  $G$ .

$$f(2x) = 2f(x)$$

Now suppose  $F$  possesses no element of order 4 but there exists again  $(x, y)$  such that

$$(7) \quad f(x+y) = -(f(x) + f(y))$$

Then we compute  $f(2x+y)$  in two ways

$$f(2x+y) = f(x+(x+y)) = \epsilon(f(x) + f(x+y)) = -\epsilon f(y) \quad \epsilon = \pm 1$$

and

$$f(2x+y) = \epsilon'(f(2x) + f(y)) = \epsilon'(2f(x) + f(y)) \quad \epsilon' = \pm 1$$

Thus

$$\epsilon'' f(y) = 2f(x) + f(y) \quad \epsilon'' = \pm 1$$

In the same way

$$\epsilon''' f(x) = 2f(y) + f(x) \quad \epsilon''' = \pm 1$$

If  $\epsilon'' = 1, \epsilon''' = 1$ , then  $2f(x) = 2f(y) = 0$ .

If  $\epsilon'' = 1, \epsilon''' = -1$ , then  $2f(x) = 0$  and  $2f(y) = -2f(x) = 0$ .

If  $\epsilon'' = -1, \epsilon''' = -1$ , then  $2f(x) + 2f(y) = 0$ .

If  $\epsilon'' = -1, \epsilon''' = 1$ , then  $2f(y) = 0$  and  $2f(x) = -2f(y) = 0$

In all cases,  $2f(x) + 2f(y) = 0$ , which means

$$(8) \quad f(x) + f(y) = -f(x) - f(y)$$

Using (7), we deduce from (8) that  $f$  is additive. A similar proof works if we suppose that  $F$  contains no element of order 4.

Note 2 Suppose  $G$  is a group and  $F$  is abelian, it is easy to prove that all the solutions of the functional equation  $f: G \rightarrow F$



$$(9) \quad f(x+y) + f(x) + f(y) = 0$$

are given by

$$f(x) = \alpha + g(x)$$

where  $\alpha$  is any element of order 3 in  $F$  and  $g$  any additive function from  $G$  into the subgroup of all elements  $y$  in  $F$  such that  $2y = 0$ . (We deduce from (9) that  $3f(0) = 0$ , then  $g(x) = f(x) - f(0)$  satisfies Eq (9) with  $g(0) = 0$ . Therefore, with  $y = 0$  in (9), this equation yields  $2g(x) = 0$  and we may write as well the equation (9) for  $g$  in the following form:  $g(x+y) = g(x) + g(y)$ ).

In other words, with the hypothesis of Proposition 5.2, the family of all solutions of the alternative equation

$$f(x+y) = f(x) + f(y) \quad \text{if} \quad f(x+y) \neq -f(x) - f(y)$$

precisely splits into either solutions of  $f(x+y) = f(x) + f(y)$  or solutions of  $f(x+y) = -f(x) - f(y)$ . There is no mixing or intertwining behaviours of the two functional equations.

Such a result leads to the following open question: Is there some intertwining behaviours for the following conditional Cauchy equation

$$f(x+y) = f(x) + f(y) \quad \text{if} \quad g(x+y) \neq g(x) + g(y)$$

where both  $f: G \rightarrow F$  and  $g: G \rightarrow F$ ? Even for  $F = G = \mathbb{R}$ , but without any regularity assumptions for one of the unknown function  $f, g$ , the problem is not yet resolved.

Note 3 The proof of Theorem 5.5 leads us very close to the general solution of Eq (1) where  $G$  is an abelian group and  $F$  an integral domain of characteristic zero. We state here the general result. The

proof requires now only elementary computations which we avoid.

Theorem 5.8 Let  $G$  be an abelian group and  $F$  be an integral domain of characteristic zero. Let  $f: G \rightarrow F$  be a solution of the functional equation

$$(1) \quad (f(x+y)-f(x)-f(y))(f(x+y)-af(x)-bf(y)) = 0$$

where  $a, b$  are given in  $F$ .

We then get the following four mutually exclusive possibilities:

- ( $\alpha$ )  $a + b = 1$ ,  $\text{Ker } f = \emptyset$  and  $f$  is a constant (non zero) function
- ( $\Gamma$ )  $a + b = 0$ ,  $\text{Ker } f$  is of index 2 and  $f(x) = 0$  for  $x \in \text{Ker } f$ ,  $f(x) = y_0$  for  $x \notin \text{Ker } f$  where  $y_0 \neq 0$  is an arbitrary element of  $F$ .
- ( $\Upsilon$ )  $a + b = -1$ ,  $\text{Ker } f$  is of index 3 and  $f(x) = 0$  for  $x \in \text{Ker } f$ ,  $f(x) = y_0$  for  $x \in x_0 + \text{Ker } f$  and  $f(x) = -y_0$  for  $x \in -x_0 + \text{Ker } f$  where  $x_0 \notin \text{Ker } f$ ,  $y_0 \neq 0$  is an arbitrary element of  $F$ .

( $\delta$ )  $a, b$  arbitrary,  $f$  is a Cauchy solution and  $\text{Ker } f$  has an infinite index

( $\epsilon$ )  $a, b$ , arbitrary,  $f$  is identically zero.

Example Let  $G = F = \mathbb{Z}$ , the additive group of integers. Any solution  $f: \mathbb{Z} \rightarrow \mathbb{Z}$  of

$$(f(n+m)-f(n)-f(m))(f(n+m)-af(n)-bf(m)) = 0$$

with  $a, b \in \mathbb{Z}$  has one of the following form

- ( $\alpha$ )  $f(n) = n_0$ ,  $n_0 \in \mathbb{Z} (n_0 \neq 0)$  (possible if and only if  $a + b = 1$ )
- ( $\beta$ )  $f(n) = 0$  for even  $n$ ,  $f(n) = n_0$  for odd  $n (n_0 \neq 0)$  (possible if and only if  $a + b = 0$ )

(γ)  $f(n) = 0$  for  $n = 3h$ ,  $f(n) = n_0$  for  $n = 3h+1$  and  $f(n) = -n_0$   
for  $n = 3h+2$  ( $n_0 \neq 0$ ) (possible if and only if  $a + b = 1$ ).

(δ)  $f(n) = n_0 n$  where  $n_0 \in \mathbb{Z}$ .

A further generalization was made. We only state the result without proof.

Theorem 5.9 Let  $G$  be an abelian group and  $F$  be an integral domain of characteristic zero. Suppose  $f: G \rightarrow F$  satisfies

$$(10) \quad (f(x+y)-af(x)-bf(y))(f(x+y)-cf(x)-df(y)) = 0$$

where  $a, b, c$  and  $d$  are in  $F$ . Suppose  $f(0) = 0$ . Then  $f$  is identically zero, except in the following four cases

$$\begin{cases} a = b = 1 \\ b = c = 1 \\ a = d = 1 \\ c = d = 1 \end{cases}$$

The first and last case are solved with Theorem 5.8 (See bibliography for the complete solution of (10)). An interesting case is the following.

Let  $Z$  be a subset of  $G$  such that  $0 \in Z$ ,  $Z + Z \subset Z$  and  $Z' + Z' \subset Z'$  where  $Z'$  is the complement of  $Z$  in  $G$ . We define  $f: G \rightarrow F$  according to

$$\begin{cases} f(x) = h & \text{for } x \in Z \\ f(x) = h' \quad (h' \neq h) & \text{for } x \in Z' \end{cases}$$

Then it is easy to verify that  $f$  is a solution of (10) with  $a = d = 1$ ,  $b = c = 0$ , i.e.

$$(11) \quad (f(x+y)-f(x))(f(x+y)-f(y)) = 0$$

Therefore a solution of (10) is not always a solution of some equation like Eq (1). We easily deduce that a subset  $Z$  having the stated properties is such that  $Z \cup (-Z) = G$  (As  $0 \in Z'$ , we cannot have both  $x'$  and  $-x'$  in  $Z'$ ). Therefore,  $Z$  has to be "thick" enough. If, for instance, the abelian group  $G$  is a complete metrizable topological group, or a locally compact abelian group, then a subset like  $Z$  must be of second Baire category, and if Haar measurable, of positive Haar measure.

It can be proved that if  $0 \in Z \neq G$ , and if  $Z$  is Haar measurable in a locally compact abelian group  $G$ , then  $Z$  and  $Z'$  have both a non empty interior  $Z^\circ$  and  $Z'^\circ$ . Moreover  $Z \setminus Z^\circ$ ,  $Z' \setminus Z'^\circ$  have zero Haar measure. In the case of  $\mathbb{R}$  (or  $\mathbb{R}^n$ ), the following holds

Proposition 5.3 Let  $Z \subset \mathbb{R}$ , such that  $0 \in Z \neq \mathbb{R}$ ,  $Z + Z \subset Z$  and  $Z' + Z' \subset Z'$  where  $Z'$  is the complement of  $Z$ . Suppose there exists non empty open subsets  $\theta$  and  $\theta'$  of  $\mathbb{R}$  such that  $\theta \cap Z$  and  $\theta' \cap Z'$  are of first Baire category.

Then  $Z = [0, \infty[$  or  $Z = ]-\infty, 0]$ .

Proof We already noticed that  $Z$  was of second Baire category. Therefore, the proof of Corollary 3.2 yields that  $Z + Z$  contains a non-empty interval  $]a, b[, a < b$ .

Suppose  $0 \leq a$ , then for any integer  $n > \frac{a}{b-a}$ ,  $nb > (n+1)a$  so that  $Z \supset \bigcup_{n=1}^{\infty} ]na, nb[ \supset ]c, \infty[$  for some  $c$  in  $[0, \infty[$ .



Let  $]a', b'[,$  be any interval with  $0 < a' < b'$ . We show that  $Z' \cap ]a', b'[,$  is of first Baire category by way of contradiction. To see this we notice that if  $Z' \cap ]a', b'[,$  were of second Baire category, then  $Z' \cap ]2a', 2b'[,$  would contain an interval for the same reason for  $Z'$  as the one for  $Z$  deduced from Corollary 3.2. As a similar consequence,  $Z'$  would contain  $]c', \infty[$  for some  $c'$  in  $[0, \infty[$ . There is a contradiction as  $Z \cap Z' = \emptyset$ . In other words,  $Z \cap ]a', b'[,$  is of second Baire category and so  $Z \cap ]2a', 2b'[,$  contains an interval  $]a'', b''[,$  with  $2a' \leq a'' < b'' \leq 2b'$ . Suppose now  $\alpha > 0$  and there exists a  $\beta, \beta > \alpha$  such that  $] \alpha, \beta[ \subset Z$ . Let  $\gamma = \sup\{\beta \mid \beta \geq 0; ] \alpha, \beta[ \subset Z\}$ . We prove  $\gamma = +\infty$ . Clearly  $] \alpha, \gamma[ \subset Z$  and  $\gamma - \alpha > 0$ . Using  $2b' = \gamma - \alpha$  and  $a' < b'$ , we find  $a'', b'', 2a' \leq a'' < b'' < \gamma - \alpha$  such that  $]a'', b''[ \subset Z$ . But then  $] \alpha, \gamma[ + ]a'', b''[ = ]a'' + \gamma, b'' + \gamma[ \subset Z + Z \subset Z$  and as  $a'' + \alpha < \gamma$ , we deduce that  $] \alpha, b'' + \gamma[ \subset Z$ , contradicting the definition of  $\gamma$  as a finite l.g.b. Therefore  $] \alpha, \infty[ \subset Z$ . But as  $a', b'$  are arbitrary positive numbers, then  $]0, \infty[ \subset Z$  and  $0 \in Z$  yields  $[0, \infty[ \subset Z$ . The analogous conclusion  $] -\infty, 0] \subset Z$  would be deduced along the same line if  $a < 0$ . A similar proof leads to

Proposition 5.4 Let  $Z \subset \mathbb{R}$  be a Lebesgue measurable subset such that  $0 \in Z \neq \mathbb{R}, Z + Z \subset Z$  and  $Z' + Z' \subset Z'$  where  $Z'$  is the complement of  $Z$ . Then  $Z = [0, \infty[$  or  $Z = ] -\infty, 0]$ .

With some more attention, the following can be proved (see bibliography for the proof).

Proposition 5.5 Let  $Z \subset \mathbb{R}^n, 0 \in Z \neq \mathbb{R}^n, Z + Z \subset Z$  and  $Z' + Z' \subset Z'$  where  $Z'$  is the complementary subset of  $Z$  in  $\mathbb{R}^n$ . Suppose there exists

an open subset  $\theta$  of  $\mathbb{R}^n$  such that the difference set  $\theta \Delta Z$  is of first Baire category. There exists an  $(n-1)$ -dimensional hyperplane  $H$  containing the origin such that  $Z = P \cup Z_0$  where  $P$  is one of the two open half spaces determined in  $\mathbb{R}^n$  by  $H$ , and  $Z_0$  is a subset of  $H$  having with respect to  $H$  the same properties as  $Z$  in  $\mathbb{R}^n$ .

5.3 Conditional Cauchy Equations of Type III<sub>2</sub>

The general situation of type III<sub>2</sub> is for the conditional subset  $Z$  to be of the following form:

$$(1) \quad Z = [(x,y) | x \in G, y \in G, xy \notin X]$$

where  $X \subset G$  with  $\emptyset \neq X \neq G$  and  $f: G \rightarrow F$ . Let  $X'$  be the complement of  $X$  in  $G$ . We write as well  $Z = [(x,y) | x \in G, y \in G, xy \in X']$ . We define  $Y \subset G$  according to

$$Y = [y | y \in G; f(y^{-1}) = (f(y))^{-1}].$$

For  $x \notin X$ , we get  $f(x) = f(x)f(1)$  and as  $X' \neq \emptyset$ , we deduce that  $f(1) = 1$ . Moreover  $f(x) = f(xyy^{-1}) = f(xy)f(y^{-1})$ .

In other words, we obtain type II for  $f: G \rightarrow F$

$$(2) \quad f(xy) = f(x)f(y) \quad \text{for all } (x,y) \in X' \times Y$$

It should immediately be noticed that  $Y$  is not an empty set as it contains  $X'X'^{-1}$  because of the following computation for  $x_1$  and  $x_2$  in  $X'$

$$f(x_1) = f(x_1x_2^{-1})f(x_2) \quad \text{and} \quad f(x_2) = f(x_2x_1^{-1})f(x_1)$$

so that

$$f(x_1x_2^{-1}) = f(x_1)(f(x_2))^{-1} \quad \text{and} \quad f(x_2x_1^{-1}) = f(x_2)(f(x_1))^{-1}$$

We deduce that

$$f(x_1x_2^{-1})f(x_2x_1^{-1}) = 1$$

and so  $y = x_1x_2^{-1} \in Y$  for any  $x_1, x_2 \in X'$ .

a) If we were to suppose  $1 \in X'$ , we would deduce that  $Y = G$  as for all  $x$  in  $G$ :

$$1 = f(1) = f(x)f(x^{-1})$$

We then get, as could have been guessed, a type I equation:

$$(3) \quad f(xy) = f(x)f(y) \quad \text{for all } (x,y) \in X' \times G$$

Such a condition is then redundant whenever the subgroup generated by  $X'$  in  $G$  is  $G$ , and then  $(Z,G,F)$  is redundant with  $Z$  as defined as in (1). But by Theorem 3.2, we also know the general solution of (3), even in the non abelian case (cf Note 2 after Theorem 3.2). Conversely, if  $f$  satisfies Eq (3) and if  $Y = G$ , then  $f$  satisfies a  $Z$ -conditional Cauchy equation with  $Z$  as in (1).

b) A similar conclusion would hold if we were to suppose that there exists  $x_0$  in  $X'$  such that for all  $y$  in  $G$ ,  $f(y) = f(yx_0^{-1})f(x_0)$

(a) appears as a special case of b) with  $x_0 = 1$ . In such a case, we deduce that for  $xy \in X'$

$$f(xy) = f(xy x_0^{-1})f(x_0) \quad \text{or} \quad f(xy x_0^{-1}) = f(xy)(f(x_0))^{-1}$$

Therefore

$$\begin{aligned} f(xy x_0^{-1}) &= f(x)f(y)(f(x_0))^{-1} \\ &= f(x)f(yx_0^{-1}) \end{aligned}$$

In other words, whenever  $xt \in X'' = X'x_0^{-1}$ , we get

$$(4) \quad f(xt) = f(x)f(t)$$

which is type III<sub>2</sub> as in a) because  $X''$  contains 1.

c) Suppose  $G$  and  $F$  are abelian groups and  $f: G \rightarrow F$  is a  $Z$ -additive function with  $Z$  as in (1). We notice that

$$(5) \quad f(x_0) = f(x_0 - y + y) = f(x_0 - y) + f(y) \quad \text{for all } y \text{ in } G$$

and as a consequence

$$(6) \quad f(x+y) = f(x) + f(x_0) - f(x_0-y)$$

Let  $T = X' - x_0$  and  $t = x + y - x_0 \in T$ . Define  $g: G \rightarrow F$  according to

$$(7) \quad g(z) = f(z+x_0) - f(x_0)$$

Then

$$\begin{aligned} g(t) &= f(x+y) - f(x_0) \\ &= f(x) - f(x_0-y) \\ &= f(t-y+x_0) - f(x_0-y) && \text{using (6)} \\ &= g(t-y) - g(-y) \end{aligned}$$

With  $s = -y$ ,  $s$  arbitrary in  $G$  and  $t$  in  $T$ , we deduce that

$$(8) \quad g(t+s) = g(t) + g(s) \quad s \in G, t \in T$$

Therefore,  $g$  satisfies a conditional Cauchy equation of type I, with a cylinder  $G \times T$ . Conversely, let  $g: G \rightarrow F$  be a solution of the condition Eq (8). We compute with  $s = -y$ ,  $y \in G$ , for all  $t$  in  $T$ , and for an  $f$  linked to  $g$  by (7) that :

$$\begin{aligned} g(t) &= f(x+y) - f(x_0) \\ &= g(t-y) - g(-y) \\ &= f(t-y+x_0) - f(x_0-y) \\ &= f(x) - f(x_0-y) \end{aligned}$$

Thus

$$(9) \quad f(x+y) = f(x) + f(x_0) - f(x_0-y) \quad \text{whenever } x + y \in X'$$

For (9) to imply Z-additivity, we must add

$$(10) \quad f(y) + f(x_0-y) = f(x_0) \quad \text{for all } y \in G.$$

We could then give the general solution of Z-additivity using Theorem 3.2.

We shall content ourselves with the case where the subgroup generated by  $X'$  is  $G$ . Then  $T$  generates  $G$  as well. Suppose  $F$  is a group with an element of order greater than 2. We may apply Theorem 3.1 so that  $g$  is additive, (10) is always satisfied and  $f$  is additive as well.

Therefore  $(Z, G, F)$  is redundant.

When  $X'$  does not generate  $G$ , then in general  $(Z, G, F)$

is not redundant. We may add

Proposition 5.6 Suppose  $G = \mathbb{R}^n$  or  $G = \overline{\mathbb{T}}^n$  (where  $\overline{\mathbb{T}} = \mathbb{R}/\mathbb{Z}$ ). Let  $X'$  be a subset of strictly positive Lebesgue measure. Let  $Z = (x, y); x \in G, y \in G; x + y \in X'$ . Condition  $(Z, G, \mathbb{R})$  is redundant.

5.4 A Dual Equation of Mikusinski Functional Equation

With Mikusinski equation, the condition was  $f(x+y) \neq 0$ , that is the left member of the Cauchy equation. By a kind of duality, it seems interesting to investigate the condition using the right member  $f(x) + f(y) \neq 0$ . Subgroups of index 2 of  $G$  will then be replaced by subgroups of order 2 in  $F$ .

Theorem 5.10 Suppose that  $G$  is a group and  $F$  a group with no subgroup of order 2. Define  $Z$

$$Z = \{(x, y) \in G \times G; f(x)f(y) = 1\}$$

Condition  $(Z, G, F)$  is redundant.

Proof. First we notice that  $f(1) = 1$ . In fact, if there exists an  $x$  with  $f(x)f(1) \neq 1$ , then  $f(x) = f(x \cdot 1) = f(x)f(1)$  and so  $f(1) = 1$ . On the contrary, if  $f(x)f(1) = 1$  for all  $x$ , then  $(f(1))^2 = 1$  and so  $f(1) = 1$  as  $F$  has no elements of order 2. Note that  $f(x^{-1}) = (f(x))^{-1}$  for all  $x$  in  $G$ . In fact, if  $f(x)f(x^{-1}) \neq 1$  then we get  $1 = f(1) = f(xx^{-1}) = f(x)f(x^{-1}) \neq 1$  which is a contradiction.

We introduce  $F_x = \{y \in G; f(x)f(y) = 1\}$  and  $H_x = x \cdot F_x$ . We have  $x^{-1} \in F_x$  and so  $1 \in H_x$ . Let us now prove that  $H_x = H_{x'}$  for all  $x, x'$  in  $G$ . It is enough to show that  $H_x \subset H_{x'}$ . Our hypothesis yields

$$(1) \quad f(x') \cdot f(x'^{-1}z) \neq 1$$

and

$$(2) \quad f(x) \cdot f(x^{-1}z) = 1.$$

From (1), we deduce  $f(z) \neq 1$  and from (2), we deduce  $f(x) = f(z)$ .

(If not, then  $f(x^{-1})f(z) \neq 1$  and so  $f(x)f(x^{-1}z) = f(x) \cdot f(x^{-1}) \cdot f(z) = f(z) = 1$ )

which is a contradiction.)

We may write  $f(x) = f(z^{-1})f(zx)$  because from  $f(z)f(x) = (f(z))^2 \neq 1$ , as  $f(z) \neq 1$ , we deduce  $f(zx) = f(z)f(x)$ . Now, with the help of (2)

$$1 = f(x)f(x^{-1}z) = f(z^{-1})f(zx)f(x^{-1}z).$$

But  $f(zx)f(x^{-1}z) \neq 1$ , as the contrary implies  $1 = f(z^{-1})$  and then  $1 = f(z)$ , which leads to a contradiction. Thus

$$1 = f(z^{-1})f(zxx^{-1}z) = f(z^{-1})f(z^2) = f(z^{-1})f(z)f(z)$$

as  $(f(z))^2 \neq 1$ , so that  $f(z) = 1$ . This is the required contradiction.

Now, if  $x \in \text{Ker } f = \{y \in G; f(y) = 1\}$ , we get  $F_x = \text{Ker } f$ . But  $\text{Ker } f$  is a subgroup. In fact, using  $f(x^{-1}) = (f(x))^{-1}$ , it is enough to prove that if  $x, y \in \text{Ker } f$ , then  $xy \in \text{Ker } f$ . Suppose on the contrary that  $f(xy) \neq 1$ . Then  $f(xy)(f(y))^{-1} \neq 1$  and so we get  $f(xy)f(y^{-1}) \neq 1$ , yielding  $f(x) \neq 1$ , which is a contradiction. Now, we get  $H_x = \text{Ker } f$  for any  $x$  in  $\text{Ker } f$  and so  $H_x = \text{Ker } f$  for all  $x$  in  $G$ .

Let  $f(x)f(y) \neq 1$ ; then  $f(xy) = f(x)f(y)$ . Now, let  $f(x)f(y) = 1$ ; then  $y = x^{-1}z$  where  $z \in \text{Ker } f$ . So

$$f(xy) = f(xx^{-1}z) = f(z) = 1 = f(x)f(y).$$

Thus,  $f: G \rightarrow F$  is multiplicative.

Instead of solving the second problem in the non abelian case IV<sub>1</sub>, let us only mention the following

Proposition 5.7 If  $f: G \rightarrow F$  is a  $Z$ -multiplicative function for  $Z = \{(x, y) \in G \times G; f(x)f(y) \neq 1\}$  then

$$(f(xy))^2 = f(x)f(y)f(x)f(y) \text{ for all } (x,y) \in G \times G.$$

If  $F$  is an abelian group, we get  $2f(xy) = 2f(x) + 2f(y)$  for all  $x$  and  $y$  in  $G$ .

Proof. The result is obvious if  $f(x)f(y) \neq 1$ . If  $f(x)f(y) = 1$  then  $y = x^{-1}z$  where  $z \in H_x$  using the notations introduced for the proof of Theorem 5.10. Consequently,  $f(xy) = f(z)$ . If  $z \in \text{Ker } f$ , the proposition is proved. If  $z \notin \text{Ker } f$ , we necessarily get  $f(x) = f(z)$ . (If not,  $f(x^{-1})f(z) \neq 1$  but then  $1 = f(x)f(x^{-1}z) = f(x)f(x^{-1})f(z) = f(z)$ , which is impossible.) Suppose now  $(f(z))^2 \neq 1$ . We get  $f(zx) = f(z)f(x)$  and so

$$1 = f(x)f(x^{-1}z) = f(z^{-1})f(zx)f(x^{-1}z).$$

But  $f(zx) \cdot f(x^{-1}z)$  must be different from 1 as  $f(z^{-1}) = (f(z))^{-1} \neq 1$ .

Then

$$1 = f(z^{-1})f(z^2).$$

Thus we have proved that  $f(x)f(y) = 1$  yields  $(f(z))^2 = 1$ . By definition of  $z$ , we get  $f(z) = f(xy)$  so that  $(f(xy))^2 = 1$  and so

$$(f(xy))^2 = f(x)f(y)f(x)f(y)$$

which ends the proof.

Proposition 5.8 Suppose  $F$  possesses an element of order 2 and define  $Z = \{(x,y) \in G \times G: f(x)f(y) \neq 1\}$ . For any  $G$ , condition  $(Z,G,F)$  is not redundant.

Proof. Consider  $f(x) = c$  where  $c^2 = 1$  and  $c \neq 1$ , or  $f(x) = c$  for all  $x \neq 1$  and  $f(1) = 1$ .

We may in fact obtain the general solution of the conditional Cauchy equation

for  $Z = \{(x,y) \in G \times G: f(x)f(y) \neq 1\}$  in the abelian case.

Proposition 5.9 Let  $F, G$  be abelian groups. Then  $f: G \rightarrow F$  is  $Z$ -additive where  $Z = \{(x,y) \in G \times G: f(x) + f(y) \neq 0\}$  if and only if  $f$  is additive, or if  $f(x) \equiv y_0$  ( $y_0 \in F$ ) or  $f(x) = 0$  for  $x \in \kappa$ ,  $f(x) = y_0$  for  $x \notin \kappa$  where  $2y_0 = 0$  ( $y_0 \neq 0$ ) and where  $\kappa$  is a subgroup of  $G$ .

Type  $IV_2$  is still not solved in general. We shall simply refer to the bibliography.

5.5 Conditional Cauchy Equations in the "Tubular" Case

We shall briefly deal with the "tubular" case and on the real axis only. The tubular condition is for  $Z = [(x,y) | (x,y) \in \mathbb{R}^2; y \in E_x]$  where  $E_x$  is, for each  $x$  in  $\mathbb{R}$ , a non empty open convex subset of  $\mathbb{R}$ . Such a tubular condition is not redundant, nor even redundant within the class of continuous functions, if we do not impose any other restriction on  $E_x$ . For example, let  $E_x = ]\frac{1}{x}, \frac{2}{x}[$  with  $0 < |x| \leq 1$ ,  $E_x = ]x, 2x[$  for  $|x| \geq 1$  and take for  $E_0$  some open interval of  $\mathbb{R}$ . Any function equal to 0 at 0 and such that  $f(x) = x$  for all  $|x| \geq 1$  is a solution of the Cauchy equation under the corresponding tubular condition.

Thus we shall add  $\bigcup_{x \in \mathbb{R}} (x + E_x) = \mathbb{R}$ . Let  $I_{loc}$  denote the class of all

locally Lebesgue integrable numerical functions.

Theorem 5.11 Let  $Z$  be a tubular condition such that  $\bigcup_{x \in \mathbb{R}} (x + E_x) = \mathbb{R}$  and suppose that  $x \rightarrow b(x) = \sup_{y \in E_x} y$  is upper semi continuous while

$x \rightarrow a(x) = \inf_{y \in E_x} y$  is lower semi-continuous. Then  $(Z, \mathbb{R}, \mathbb{R})$  is  $I_{loc}$ -redundant.

Proof Fix  $x$  in  $\mathbb{R}$  and let  $a(x) < c < d < b(x)$ . As  $b(x)$  is u.s.c., there exists an open neighbourhood  $\theta_x^1$  of  $x$  such that  $b(y) > d$  for all  $y$  in  $\theta_x^1$ . As  $a(x)$  is l.s.c., there exists an open neighbourhood  $\theta_x^2$  of  $x$  such that  $a(y) < c$  for all  $y$  in  $\theta_x^2$ . With  $\theta_x = \theta_x^1 \cap \theta_x^2$ , which is an open neighbourhood of  $x$ , we deduce that  $[c, d]$  is included in  $E_y$  for all  $y$  in  $\theta_x$ .

Let us now integrate the Cauchy conditional equation on  $[c, d]$  for all  $y$  in  $\theta_x$  and using  $\int_c^d f(y+z) dz = \int_{y+c}^{y+d} f(z) dz$ :

$$(1) \quad \int_{y+c}^{y+d} f(z) dz = (d-c)f(y) + \int_c^d f(z) dz$$

By (1), as  $f$  belongs to  $I_{loc}$ , we deduce that  $f$  is continuous on  $\theta_x$ . Using (1) once more, we deduce that  $f$  is differentiable on  $\theta_x$  with a continuous derivative. As  $x \in \theta_x$ , we deduce that  $f$  has a continuous derivative everywhere on  $\mathbb{R}$ .

We now differentiate the conditional Cauchy equation with respect to  $x$

$$(2) \quad f'(x+y) = f'(x) \quad \text{for all } y \text{ in } E_x.$$

Let  $y_0 = f'(x_0)$  for some  $x_0$  in  $\mathbb{R}$  and consider  $Y_0 = [x | x \in \mathbb{R}; f'(x) = y_0]$ .

As  $f'$  is continuous,  $Y_0$  is a non empty closed subset of  $\mathbb{R}$ . Now let  $z \in Y_0$ . As  $\bigcup_{x \in \mathbb{R}} (x + E_x) = \mathbb{R}$ , there exists  $x$  in  $\mathbb{R}$  such that  $z \in x + E_x$ . But (2) proves that  $f'$  is constant on  $x + E_x$  which is an open subset.

Thus  $Y_0$  is open. As  $\mathbb{R}$  is a connected topological space, we deduce  $Y_0 = \mathbb{R}$  or  $f'(x) = y_0$  for all  $x$  in  $\mathbb{R}$ . Thus  $f(x) = y_0 x + y_1$ . But the conditional Cauchy equation immediately yields  $y_1 = 0$ . This ends the proof of Theorem 5.11.

Using a selection theorem, we could study the tubular condition on metrizable topological groups but this will take us outside the scope of the present text.



5.6 Conditional Cauchy Equations of Type V

Suppose  $Z$  is a subset of the plane  $\mathbb{R}^2$  such that its complement  $Z^c$  is of Lebesgue measure zero. What can be said about a  $Z$ -additive function? Could we expect that if  $f: \mathbb{R} \rightarrow \mathbb{R}$  is  $Z$ -additive, then there exists an additive  $g: \mathbb{R} \rightarrow \mathbb{R}$  such that  $g = f$  almost everywhere? At first glance, the answer appears to be obviously yes. It however requires some detailed study. It is even possible to treat the problem in a fairly general way, using the notion of a proper linearly invariant ideal. Let  $G$  be a group (with additive notations, even if  $G$  is not necessarily abelian).

Definition 5.1 A non-empty family  $\tau$  of subsets of  $G$  is called a proper linearly invariant ideal if the following properties are simultaneously satisfied:

- (i) If  $A$  and  $B$  are in  $\tau$ , then  $A \cup B \in \tau$
- (ii) If  $A \in \tau$  and  $B \subset A$  then  $B \in \tau$
- (iii) For any  $x$  in  $G$ , and  $A$  in  $\tau$ ,  $x + A \in \tau$
- (iv)  $\tau$  is proper ( $G \notin \tau$ ).

It is easy to deduce that  $x + A \in \tau$  and  $A + x \in \tau$  for any  $x$  in  $G$  and  $A$  in  $\tau$ . The most common example of proper linearly invariant ideals are the following ones:

- (a) Let  $G$  be a locally compact group and  $\tau$  be the family of all subsets of Haar measure zero.
- (b) Let  $G$  be a locally compact group and  $\tau$  be the family of all subsets of first Baire category.
- (c) Let  $G$  be a metrizable topological group, the diameter of which is infinite and  $\tau$  be the family of all subsets of  $G$  of finite diameter.

(d) Let  $G$  be a group, the cardinal of which is infinite and equal to  $\alpha$  and  $\tau$  be the family of all subsets of  $G$  of a cardinality strictly less than  $\alpha$ .

(e) Let  $G$  be a group endowed with an outer measure, invariant under translation and reflections with respect to 0 and suppose that  $G$  has an infinite outer measure. Take  $\tau$  to be the family of all subsets of a finite outer measure.

Once a proper linearly invariant ideal is given on  $G$ , we can always construct another one on the product  $G \times G$ , in the following way.

Definition 5.2 Let  $\tau$  be a proper linearly invariant ideal on a group  $G$ .

Then  $\tau\tau$  is the family of all subsets  $Z$  of  $G \times G$  such that except perhaps for all  $x$  in  $G$  belonging to a member of  $\tau$ , the section  $Z_x = [y | y \in G, (x, y) \in Z]$  belongs to  $\tau$ .

It is easy to prove that  $\tau\tau$  is a proper linearly invariant ideal on  $G \times G$ .

If  $\tau$  is a proper linearly invariant ideal on  $G$  and  $\tau'$  another one on  $G \times G$ , we say that  $\tau$  and  $\tau'$  are conjugate if the vertical section  $Z_x = [y | y \in G, (x, y) \in Z]$  of any subset  $Z$  of  $\tau'$  belongs to  $\tau$  except perhaps for all  $x$  belonging to some element of  $\tau$ .

$\tau\tau$  is the largest proper linearly invariant ideal of  $G \times G$  conjugate to  $\tau$ .

Definition 5.3 Let  $\tau$  (in  $G$ ) and  $\tau'$  (in  $G \times G$ ) be conjugate proper linearly invariant ideals where  $G$  is a group. Suppose that for any  $Z$  in  $G \times G$ , such that its complement belongs to  $\tau'$  and for any  $Z$ -additive  $f: G \rightarrow F$ , where  $F$  is a group, there exists an additive  $g: G \rightarrow F$



such that  $f(x) = g(x)$  for all  $x$ , except perhaps those  $x$  belonging to some subset in  $\tau$ . We then say that  $(\tau', \tau, G, F)$  is almost redundant.

**Theorem 5.12** Let  $G$  be a group. Let  $\tau$  (in  $G$ ),  $\tau'$  (in  $G \times G$ ) be conjugate proper linearly invariant ideals. Let  $F$  be any group. Then  $(\tau', \tau, G, F)$  is almost redundant.

It is enough to prove that  $(\tau, \tau, G, F)$  is almost redundant. So let  $f: G \rightarrow F$  be  $Z$ -additive where  $Z'$  belongs to  $\tau$ . Let  $X'$  be the set of all  $x$  in  $G$  such that the section  $Z'_x = [y | y \in G, (x, y) \in Z']$  does not belong to  $\tau$ . By definition of  $\tau$ ,  $X'$  belongs to  $\tau$ .

For any  $x \in G$ , choose  $i(x)$  in  $G$  such that  $i(x) \notin X'$  and  $x - i(x) \notin X'$ .

This is always possible as  $\tau$  is a proper linearly invariant ideal. Let

$Y_x = Z'_{i(x)} \cup (-i(x) + Z'_{x-i(x)})$ . By our choice of  $i(x)$ , we deduce that  $Y_x$  belongs to  $\tau$ . We shall now define a function  $g: G \rightarrow F$  according to

$$(a) \quad g(x) = f(x+y) - f(y)$$

where  $y$  denotes any element of  $G$ , not belonging to  $Y_x$ . For this definition of  $g$  to make sense, we have to prove that (a) does not depend upon the particular choice made for  $y \notin Y_x$ . We compute that

$$\begin{aligned} f(x+y) - f(y) &= f(x-i(x)+i(x)+y) - f(y) \\ &= f(x-i(x)) + f(i(x)+y) - f(y) \end{aligned}$$

as  $(x-i(x), i(x)+y) \in Z$

$$= f(x-i(x)) + f(i(x)) + f(y) - f(y)$$

as  $(i(x), y) \in Z$

$$= f(x-i(x)) + f(i(x))$$

This last expression is no longer dependent upon  $y$ . Thus  $g$  is well defined via Eq (a). Let us prove that the function  $g$  is equal to  $f$ , except perhaps on  $X'$  (Recall that  $X' \in \tau$ ). Let  $x \notin X'$ . Suppose first  $(x, y) \in Z$  for some  $y \notin Y_x$ . Then

$$\begin{aligned} g(x) &= f(x+y) - f(y) = f(x) + f(y) - f(y) \\ &= f(x) \end{aligned}$$

It only remains to show that the choice of a convenient  $y$  is always possible for  $x \notin X'$ . We impose upon  $y$  the additional conditions that  $y \notin Z'_x$  and  $y \notin Y_x$ . But both  $Z'_x$  and  $Y_x$  are in  $\tau$  and thus  $Z'_x \cup Y_x$  cannot coincide with  $G$ . Therefore there is some possible choice for  $y$ .

To end the proof of Theorem 5.12, it must be proved that  $g$  is additive. The trick will be to use convenient translates. We start from  $u, v$  and  $u+v$  in  $G$ . We first find (1)  $x \notin Y_{u+v}$  and thus

$$g(u+v) = f(u+v+x) - f(x)$$

Then we find (2)  $y \notin Y_v$  and (3)  $z \notin Y_u$

$$g(v) = f(v+y) - f(y)$$

$$g(u) = f(u+z) - f(z)$$

In other words

$$g(u+v) - g(v) - g(u) = (f(u+v+x) - f(x)) - (f(v+y) - f(y)) - (f(u+z) - f(z))$$

We shall add some more conditions on  $x, y$  and  $z$  and we shall have to prove their compatibility. Let  $s$  be such that  $y = x + s$  and require that  $s \notin Z'_x$ , or

$$(4) \quad y \notin x + Z'_x$$

Thus  $f(y) = f(x+s) = f(x) + f(s)$

Let  $t \in G$  be such  $z = v + x + s + t$  and require that

$$(5) \quad t \notin Z'_{v+y}$$

Thus

$$f(v+x+s+t) = f(z) = f(v+x+s) + f(t)$$

We deduce that

$$\begin{aligned} g(u+v) - g(v) - g(u) &= f(u+v+x) + f(s) + f(t) - f(z) + f(z) - f(u+z) \\ &= f(u+v+x) + f(s) + f(t) - f(u+z) \end{aligned}$$

Suppose  $(s,t) \in Z'$  which amounts to

$$(6) \quad t \notin Z'_{-x+y}$$

Then

$$g(u+v) - g(v) - g(u) = f(u+v+x) - f(s+t) - f(u+z)$$

Suppose  $(u+v+x, s+t) \notin Z'$  which amounts to

$$(7) \quad t \notin -y + x + Z'_{u+v+x}$$

Then

$$\begin{aligned} g(u+v) - g(v) - g(u) &= f(u+v+x+s+t) - f(u+z) \\ &= 0 \end{aligned}$$

The additivity of  $g$  is thus proved as soon as we can exhibit  $x, y, z$  and  $t$  satisfying the relations (1) to (7). First we manage to obtain that all subsets occurring in relation (1) to (7) belong to  $\tau$ . This implies

$$(8) \quad x \notin X', (9) \quad y \notin -v + X', (10) \quad y \notin x + X' \text{ and } (11) \quad x \notin -v - u + X'$$

The choice of  $x$  is now possible as (1), (2) and (11) only require  $x$  not to belong to some element of  $\tau$ . The second choice is for  $y$ ,

which is also possible for the same reason taking care of (2), (4), (9) and (10). The third choice is for  $z$  and we use (3). The final choice is for  $t$ , but we then have (5), (6) and (7). This ends the proof of Theorem 5.12.

Note 1 An irritating aspect of the statement made in Theorem 5.12 is that it does not precisely explain how the exceptional set  $X''$  belonging to  $\tau$ , on which  $f$  differs from  $g$ , is related to the exceptional set  $Z'$ . By our proof, we only know that  $X''$  is included in the exceptional set  $X'$  as related to the sections  $Z'_X$ . The set  $X''$  can well be far smaller than  $X'$  in some specific cases. For instance, we get the following result (See bibliography).

Theorem 5.13 Let  $G = \mathbb{R}^n$  and  $F$  be an abelian group. Suppose  $f: G \rightarrow F$  is  $Z$ -additive where  $Z = \mathbb{R}^{2n} \setminus Z'$  with  $Z'$  of finite outer  $2n$ -dimensional Lebesgue measure. There exists an additive  $g: G \rightarrow F$  and  $f = g$  almost everywhere (for the Lebesgue measure in  $\mathbb{R}^n$ ).

Note 2 At least the additive  $g$  we have constructed is the only additive function which is equal to  $f$  except on a subset of  $\tau$ . To prove this last point, let  $h: G \rightarrow F$  and  $h(x) = g(x)$  for all  $x \notin T$  where  $T \in \tau$ . We suppose  $h$  is additive and write for any  $x$  in  $G$

$$h(x) = h(x-t) + h(t)$$

We choose  $t$  such that  $t \notin T$  and  $t \notin -T + x$ , which is possible as  $T$  and  $-T + x$  are in  $\tau$ . Then

$$h(x) = g(x-t) + g(t)$$

$$= g(x)$$

Thus  $h(x) = g(x)$  everywhere in  $G$ .

Note 3 If we replace equality by an inequality, Theorem 5.12 remains true for Jensen convex functions but is still open for subadditive functions.

We first quote

Theorem 5.14 Let  $f: \mathbb{R} \rightarrow \mathbb{R}$  be such that

$$f\left(\frac{x+y}{2}\right) \leq \frac{1}{2}(f(x)+f(y)) \quad \text{for all } (x,y) \in Z$$

where the complement of  $Z$  (in  $\mathbb{R}^2$ ) is of Lebesgue measure zero. There exists a unique Jensen convex function  $g: \mathbb{R} \rightarrow \mathbb{R}$  and  $f(x) = g(x)$  almost everywhere.

For subadditive functions, the best result available up to now is the following

Theorem 5.15 Let  $f: \mathbb{R} \rightarrow \mathbb{R}$  be such that

$$f(x+y) \leq f(x) + f(y) \quad \text{for all } (x,y) \in Z$$

where the complement of  $Z$  (in  $\mathbb{R}^2$ ) is of Lebesgue measure zero. There exist two subadditive functions  $\phi$  and  $\psi$  such that almost everywhere

$$\phi(x) \leq f(x) \leq \psi(x)$$

Moreover, if the set of all  $x$  in  $\mathbb{R}$  such that both  $f(x)$  and  $f(-x)$  are less than  $\epsilon$  has a strictly positive Lebesgue measure, then  $\phi(x) = f(x) = \psi(x)$  almost everywhere.

Quite naturally, one may ask now for the general solutions of types I, II, III or IV modulo a proper linear invariant ideal. We shall simply refer to the bibliography.

## CHAPTER VI

## FUNCTIONAL EQUATIONS WITH SUPERPOSITIONS OF THE UNKNOWN FUNCTION

Programme *In this chapter, we leave Conditional Cauchy equations for more sophisticated functional equations. The main feature of the equations to be considered is a superposition of the unknown function. Therefore, we begin by studying a functional equation linearly linking  $f(f(x))$ ,  $f(x)$  and the variable  $x$  on an abelian group. For such an equation, a simple introduction is provided on  $\mathbb{R}$  and an application is given to the characterization of inner product spaces. Afterwards two functional equations are studied. One originates from the theory of geometrical objects. The other is from functional analysis. Applications are provided to some topics in algebra.*

6.1 On a division model for a population

When a certain population is being distributed into classes (for example committees in a congress or in a department) it has often been noticed that there exists a tendency for a new subdivision to form within each class. Suppose, statistically, that the tendency to subdivide only depends upon the number of classes and is the same for any class. Is it possible, at the second subdivision, that the tendency to form a subdivision be the square of the tendency at the first division?

If  $f(n)$  denotes the number of subclasses into which each class of a family of  $n$  classes will be divided, we get  $nf(n)$  classes at the

first division. We now ask whether it is possible that

$$(1) \quad f(nf(n)) = (f(n))^2.$$

Finding all  $f: \mathbb{N} \rightarrow \mathbb{N}$  satisfying (1) is an interesting combinatorial problem which we shall not solve generally. Instead, we shall try to find solutions of (1) which can be extended to all positive real values so as to still satisfy (1). More precisely, we look for  $f: \mathbb{R}^+ = [0, \infty[ \rightarrow \mathbb{R}^+$  such that for all  $x \in \mathbb{R}^+$ :

$$(2) \quad f(xf(x)) = (f(x))^2.$$

We shall prove the following theorem.

Theorem 6.1 Let  $f: \mathbb{R}^+ \rightarrow \mathbb{R}^+$  be a continuous function. To satisfy (2) it is necessary and sufficient for  $f$  to be of one of the following forms:

$$(a) \quad f(x) = \lambda x \quad \text{where} \quad \lambda \in \mathbb{R}^+$$

$$(b) \quad f(x) = \begin{cases} \frac{x}{\lambda_1} & \text{for } 0 \leq x < \lambda_1 \\ 1 & \text{for } \lambda_1 \leq x \leq \lambda_2 \\ \frac{x}{\lambda_2} & \text{for } \lambda_2 < x \end{cases}$$

where  $\lambda_1, \lambda_2$  are any real numbers (or infinite) satisfying  $0 \leq \lambda_1 < \lambda_2 \leq +\infty$

[For example, if  $\lambda_1 = 0$ , (b) means  $f(x) = 1$  for  $0 \leq x \leq \lambda_2$  and

$f(x) = \frac{x}{\lambda_2}$  for  $x > \lambda_2$ . If  $\lambda_2 = +\infty$ , (b) means  $f(x) = \frac{x}{\lambda_1}$  for

$0 < x < \lambda_1$  and  $f(x) = 1$  for  $x \geq \lambda_1$ ). The interesting phenomenon, in view of the introduction, is the existence of an interval for the variable  $x$  where  $f$  is constant between possibly two linear growths.

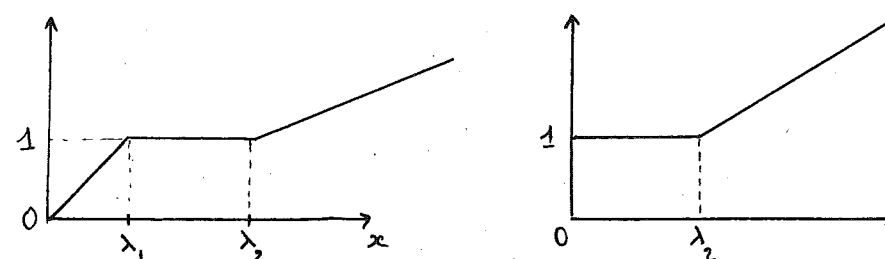

We shall prove Theorem 6.1 in two steps.

First step We first have to take care of the special role being played by 0 outside the multiplicative group  $\mathbb{R}^+ / [0]$ . Consider  $A$  where

$$A = \{x | x \geq 0; f(x) > 0\}.$$

If  $A = \emptyset$ , then  $f \equiv 0$  and we are in case (a), with  $\lambda = 0$ , in Theorem 5.1. Suppose  $A \neq \emptyset$  and let  $x_0 \in A$  be fixed. We define two numbers  $x_1, x_2$ , finite or not, as

$$x_1 = \text{Inf}\{x | x \geq 0, ]x, x_0[ \subset A\}$$

$$x_2 = \text{Sup}\{x | x \geq 0, [x_0, x[ \subset A\}$$

By contradiction, let us prove that  $x_2 = +\infty$ . If not, we get  $f(x_2) = 0$  by continuity, as well as  $f(x_1) = 0$ . Then let us define:

$$g(x) = xf(x)$$

Whatever  $x_1$  might be (zero or not), we get  $g(x_1) = g(x_2) = 0$ . For all  $x$ , with  $g(x) \neq 0$ , we also get

$$g(g(x)) = \frac{(g(x))^3}{x^2}$$

From this, we deduce that  $g: A/[0] \rightarrow \mathbb{R}^+$  is one-to-one as an equality  $g(x') = g(x'') = y \neq 0$  implies

$$g(y) = \frac{y^3}{x'^2} = \frac{y^3}{x''^2}$$

and so  $x' = x''$ . But  $g$  cannot be one-to-one and continuous on  $]x_1, x_2[$  and zero both in  $x_1$  and  $x_2$ . The contradiction leads to  $x_2 = \infty$ .

As  $x_0$  is an arbitrary element of  $A$ , we have proved that

$$A = ]x_1, \infty[.$$

By contradiction too, let us prove that  $x_1 = 0$ . We thus suppose  $x_1 > 0$

and for any  $y > \text{Log } x_1$ , we define

$$(3) \quad F(y) = \text{Log } f(e^y)$$

Then  $F: ]y_1 = \text{Log } x_1, \infty[ \rightarrow \mathbb{R}$  is a continuous function satisfying the following functional equation

$$F(y+F(y)) = 2F(y)$$

(for  $y + F(y) > y_1$ , as soon as  $y > y_1$ , due to Equation (2)).

Moreover we get a boundary condition

$$(4) \quad F(y_1^+) = \lim_{\substack{y \rightarrow y_1 \\ y > y_1}} F(y) = -\infty$$

We define  $G(y) = y + F(y)$  and for all  $y > y_1$  get

$$(5) \quad G(G(y)) = 3G(y) - 2y$$

$G: ]y_1, \infty[ \rightarrow \mathbb{R}$  is one-to-one and because of (4) satisfies

$$G(y_1^+) = \lim_{\substack{y \rightarrow y_1 \\ y > y_1}} G(y) = -\infty$$

Thus  $G$  is strictly increasing. Still using (5), we see that  $G$  cannot have a finite limit when  $y$  goes to  $+\infty$ . Thus  $G$  is a homeomorphism from  $]y_1, \infty[$  onto  $\mathbb{R}$ . Now for every  $y > y_1$ , we define  $H(y) = y - F(y)$  as a continuous function over  $]y_1, \infty[$ . We then define  $H': \mathbb{R} \rightarrow \mathbb{R}$  according to

$$H'(y) = H(G^{-1}(y))$$

The function  $H'$  is continuous and extends  $H$  outside the domain of  $H$ , i.e.  $]y_1, \infty[$ . In fact, if  $G(y) > y_1$ , we get

$$\begin{aligned} H(G(y)) &= G(y) - F(G(y)) \\ &= y + F(y) - F(y+F(y)) \\ &= H(y) \end{aligned}$$

and so  $H(z) = H(G^{-1}(z))$  for each  $z > y_1$ . However, there is a contradiction as  $H(y_1^+) = +\infty$  which prevents a continuous extension of  $H$ .

Thus we deduce  $x_1 = 0$ .

Second step We now return to the study of  $f: ]0, \infty[ \rightarrow ]0, \infty[$ . Using previous notations, the functions  $G$  and  $H$  are defined for all real values of  $y$  and satisfy

$$(6) \quad H(G^{-1}(y)) = H(y)$$

Clearly, we ought to compute  $G^{-n}(y)$  for every positive integer  $n$ . By induction, we easily get

$$G^{-n}(y) = y + (2^{-n} - 1)F(y)$$

and from (6), letting  $n$  grow to infinity, we deduce that

$$H(H(y)) = H(y)$$

Returning to  $G$ , this yields for every  $y$  in  $\mathbb{R}$

$$G(H(y)) = H(y)$$

The range of  $H$  must be an interval, which we denote by  $[\mu_1, \mu_2]$  where  $[\ ]$  means "[as well as]" and where  $-\infty \leq \mu_1 \leq \mu_2 \leq \infty$ . However we cannot simultaneously have  $\mu_1 = \mu_2 = +\infty$  or  $\mu_1 = \mu_2 = -\infty$ . We also note that the range of  $H$  coincides with the set of all fixed points of  $G$ . Such a set is closed. To take care of the different cases, we put  $\lambda_1 = e^{\mu_1}$  and  $\lambda_2 = e^{\mu_2}$  making use of the following convention:  $e^{-\infty} = 0$  and  $e^{+\infty} = +\infty$ .

$\alpha$ ) If  $\mu_1 = \mu_2 = \mu$ ,  $H$  is a constant function and so  $F(y) = y - \mu$ . Thus  $f(x) = \lambda x$  with  $\lambda = e^{-\mu} > 0$ . This completes case a) in Theorem 5.1.

$\beta$ ) If  $\mu_1 = -\infty$  and  $\mu_2 = +\infty$ , then  $G(y) = y$  for all real  $y$  and so  $F(y) \equiv 0$ . Then  $f(x) = 1$  for every  $x > 0$  and by continuity  $f(x) = 1$ . We arrive at case b) with  $\lambda_1 = 0$  and  $\lambda_2 = +\infty$ .

$\gamma$ ) If  $\mu_1 < \mu_2 < +\infty$ , we necessarily get  $F(y) = y - \mu_2$  for every  $y > \mu_2$ . To see this, take  $y > \mu_2$ . If we suppose  $H(y) \in ]\mu_1, \mu_2[$ , there exists an integer  $n_0$  such that  $G^{-n_0}(y) \in ]\mu_1, \mu_2[$ . Thus we get  $G^{-(n_0+1)}(y) = G^{-n_0}(y)$ , which contradicts the fact that  $G$  is a bijection as  $G^{-1}(y) \neq y$  for  $y > \mu_2$ . Thus either  $H(y) = \mu_2$  or  $H(y) = \mu_1$ . In the same way, using the strict monotonicity of  $G^{-1}$ , we may show that  $H(y) = \mu_1$  is not possible. So  $H(y) = \mu_2$  and  $F(y) = y - \mu_2$ , yielding  $f(x) = \frac{y}{\lambda_2}$ .

$\delta$ ) In a similar way, if  $\mu_1 > -\infty$ , we prove  $F(y) = y - \mu_1$  for  $-\infty < y < \mu_1$ . This ends the proof of Theorem 6.1.

## 6.2 A functional equation on an abelian group: linear iteration of order two

The functional equation (1), on the multiplicative semi-group  $N$ , is the typical case of a class of functional equations where the unknown function  $f$  appears in a superposition of itself. It is also a functional equation in one variable and this makes its solutions more difficult to obtain. However, we shall give here some results in the general setting of an abelian group and in §5 and §6 shall deal with cases involving two variables. The generalized equation (1) appears as follows

$$f: G \rightarrow G \quad (G, +) \text{ abelian group}$$

$$(7) \quad f(x+f(x)) = \gamma f(x)$$

where  $\gamma$  is a given integer, possibly a rational number if  $G$  is a divisible group or even a real number if  $G$  is a real linear space. Heuristically speaking, the general solution for (7) should depend upon two parameters, but as (7) remains stable under a translation, things look easier.

If  $\gamma = 1$ , Equation (7) is sometimes called Euler's functional equation, which arose from a geometrical problem due to Gergonne (cf. bibliographical notes). A simple transformation links Equation (7) with another interesting functional equation. If we define

$$g(x) = x + f(x)$$

Then  $f$  satisfies Equation (7) if and only if  $g$  satisfies Equation (8).

$$(8) \quad g(g(x)) = (\gamma+1)g(x) - \gamma x$$

If  $\gamma = 0$ , Equation (8) is the functional equation of idempotence.



If  $\gamma = -1$ , Equation (8) is the functional equation of involution. In general, Equation (8) is called the equation of linear iteration of order two as it links  $g(g(x))$  linearly with  $g(x)$  and  $x$ . We introduce a useful tool in:

Definition 6.1 Let  $G$  be a divisible abelian group. An iterative  $\gamma$ -decomposition of  $G$  consists of a non empty subset  $I$  of  $G$  and a set mapping  $x \rightarrow S_x$  from  $I$  into the family of all non empty subsets of  $G$  such that for some  $\gamma, \gamma \neq 0, \gamma \neq 1$  ( $\gamma$  rational in general, but possibly real in case  $G$  is a real linear space)

- (i)  $S_x \cap I = [x]$
- (ii)  $S_x \cap S_z = \emptyset$  for  $x \neq z$
- (iii) For  $y \in S_x, \gamma y + (1-\gamma)x \in S_x$
- (iv)  $\bigcup_{x \in I} S_x = G$

Examples Let for example  $J$  be a  $Q$ -convex subset of a divisible abelian group  $G$ ,  $Q$ -radial at the origin. Define the Minkowski gauge of  $J$  as a numerical function on  $G$

$$p(x) = \text{Inf}[\lambda | \lambda \in Q, \lambda > 0, \frac{x}{\lambda} \in J].$$

As  $J$  is  $Q$ -radial at the origin,  $p(x)$  is a well-defined real number for every element  $x$  in  $G$ . We easily get

$$p(\mu x) = \mu p(x) \quad \text{for all } x \text{ in } G, \mu \geq 0 \text{ in } Q$$

and

$$p(x+y) \leq p(x) + p(y) \quad \text{for all } x, y \text{ in } G$$

(because if  $\frac{x}{\lambda} \in J$ , then due to the convexity of  $J$ , we compute that

$$\frac{x+y}{\lambda+\lambda'} = \frac{\lambda}{\lambda+\lambda'} \left(\frac{x}{\lambda}\right) + \frac{\lambda'}{\lambda+\lambda'} \left(\frac{y}{\lambda'}\right) \in J. \quad \text{We also get}$$

$$I' = [x | x \in G; p(x) < 1] \subset J \subset [x | x \in G; p(x) \leq 1] = I$$

If we use  $I$  and  $S_x = [x]$  if  $x \in I'$ ,  $S_x = [y | y = \lambda x, \lambda \in Q, \lambda \geq 1]$  for  $x$  in  $I$  but not in  $I'$ , we easily deduce properties (i), (ii) and (iii). But (iv) fails to be true in general as can be seen with  $G = \mathbb{R}$  and  $J = [-1, +1]$ . However, if  $J$  is a closed and convex neighbourhood of the origin in a real and linear Hausdorff topological space  $G$ , we notice that  $J = [x | x \in G; p(x) \leq 1]$ . Therefore if  $S_x = [x]$  for  $p(x) < 1$  and  $S_x = [y | y = \lambda x, \lambda \in \mathbb{R}, \lambda \geq 1]$  for  $p(x) = 1$ , we get an iterative  $\gamma$ -decomposition of  $G$  (for all  $0 < \gamma < 1$ ). This last example does not exhaust iterative  $\gamma$ -decompositions of a real and linear Hausdorff topological space. Let  $G = \mathbb{R}^2$  and let  $I$  be a convex polygon. For  $x$  inside the polygon, we use  $S_x = [x]$ . For  $x$  on the boundary of the polygon, we use as  $S_x$  the half line starting from  $x$ , lying outside the polygon and being orthogonal to the side to which  $x$  belongs if  $x$  is not a vertex. Finally, we use as  $S_x$  the wedge determined by two perpendiculars to the adjacent sides if  $x$  is a vertex. We thus define an iterative  $\gamma$ -decomposition of  $\mathbb{R}^2$  (for all  $0 < \gamma < 1$ ).

Some topology may help us to solve Equation (8), by adding to it a continuity assumption. We shall restrict ourselves to topological linear spaces over the real numbers, even though we could generalize to topological linear spaces over the rational field.



Definition 6.2 Let  $G$  be a real Hausdorff topological linear space. A regular iterative  $\gamma$ -decomposition of  $G$  is an iterative  $\gamma$ -decomposition of  $G$ ,  $[S_x]_{x \in I}$ , for some real  $\gamma$ ,  $\gamma \neq 0$ ,  $\gamma \neq 1$ , such that  $I$  is a closed subset of  $G$  as well as  $S_x$  for all  $x$  in  $I$  and such that the mapping  $h: G \rightarrow G$ , defined by  $h(y) = x$  if  $y \in S_x$  is continuous. If  $0 < \gamma < 1$ , we use the expression convex decomposition instead of  $\gamma$ -decomposition.

Theorem 6.2 Let  $0 < \gamma < 1$ ,  $\gamma \in \mathbb{R}$ . Let  $G$  be a real Hausdorff topological linear space. A continuous function  $g: G \rightarrow G$  satisfies the functional equation

$$(8) \quad g(g(x)) = (\gamma+1)g(x) - \gamma x \quad \text{for all } x \text{ in } G$$

if and only if there exists a regular iterative  $\gamma$ -decomposition of  $G$  such that  $h(x) = \frac{g(x) - \gamma x}{1 - \gamma}$ .

We first prove a corollary of Theorem 6.2 and then shall proceed to the proof of this Theorem 6.2.

Corollary 6.1 Let  $0 < \gamma < 1$ ,  $\gamma \in \mathbb{R}$ . A continuous  $g: \mathbb{R} \rightarrow \mathbb{R}$  satisfies

$$g(g(x)) = (\gamma+1)g(x) - \gamma(x) \quad \text{for all } x \in \mathbb{R}$$

if and only if either there exist  $a, b$ ,  $-\infty \leq a < b \leq +\infty$  such that

$$g(x) = \begin{cases} \gamma x + (1-\gamma)a & \text{if } x < a \\ x & \text{if } a \leq x \leq b \\ \gamma x + (1-\gamma)b & \text{if } x > b \end{cases}$$

or  $g(x) = \gamma x + \delta$  for all  $x$  in  $\mathbb{R}$  where  $\delta$  is an arbitrary real number.

Proof Let  $[S_x]_{x \in I}$  be a regular iterative  $\gamma$ -decomposition of  $\mathbb{R}$ .

The continuous mapping  $h: \mathbb{R} \rightarrow \mathbb{R}$  is a topological retract as  $h(x) \in I$

for all  $x \in \mathbb{R}$  and  $h(x) = x$  for  $x$  in  $I$ . We deduce that  $I$  is a closed and connected subspace of  $\mathbb{R}$ . Some five cases have to be distinguished and altogether they give us Corollary 6.1.

$I = \mathbb{R}$  Then  $g(x) = h(x) = x$  (Corollary 6.1 with  $a = -\infty$ ,  $b = +\infty$ )

$I = \{a\}$  Then  $h(x) = a$  and  $g(x) = \lambda x + \delta$  with  $\delta = (1-\gamma)a$

$I = [a, b]$  with  $-\infty < a < b < +\infty$ . Then  $g(x) = h(x) = x$  on  $[a, b]$ .

If  $x \in S_b$ , then  $y = \gamma x + (1-\gamma)b \in S_b$ . But  $y - b = \gamma(x-b)$

which by iteration yields  $x > b$ . We easily deduce that

$S_b = [b, \infty$  [and  $S_a = ]-\infty, a]$ . Then for

$x \geq b$ ,  $h(x) = b$  and so  $g(x) = \gamma x + (1-\gamma)b$ , and for

$x \leq a$ ,  $h(x) = a$  and so  $g(x) = \gamma x + (1-\gamma)a$

$I = ]-\infty, b]$  with  $b < +\infty$ . Thus we easily get  $g(x) = x$  for

$x \leq b$  and  $g(x) = \gamma x + (1-\gamma)b$  for  $x \geq b$

$I = [a, +\infty[$  with  $a > -\infty$ . Then we easily get  $g(x) = x$  for

$x \geq a$  and  $g(x) = \gamma x + (1-\gamma)a$  for  $x \leq a$ .

This ends the proof of Corollary 6.1, once Theorem 6.2 is proved. The technique which shall be used for the proof of Theorem 6.2 makes a fundamental use of the continuity of the function  $g$ . It remains an open problem to find the general solution of Eq (8), even on  $\mathbb{R}$ .

We shall now proceed to the proof of Theorem 6.2.

Proof of Theorem 6.2 Suppose  $(S_x)_{x \in I}$  is a regular iterative  $\gamma$ -decomposition of  $G$  and  $g(x) = (1-\gamma)h(x) + \gamma x$  for all  $x$  in  $G$ . Then

$$\begin{aligned} g(g(x)) &= (1-\gamma)h[(1-\gamma)h(x) + \gamma x] + \gamma g(x) \\ &= (1-\gamma)h(x) + \gamma g(x) && \text{due to (iii)} \\ &= g(x) - \gamma x + \gamma g(x) = (\gamma+1)g(x) - \gamma x \end{aligned}$$

which is Equation (8). As  $h$  is continuous, so is  $g$ .

Conversely, let  $g: G \rightarrow G$  be a continuous solution of the iteration Equation (8). We define  $h: G \rightarrow G$  according to

$$(9) \quad \frac{g(x) - \gamma x}{1-\gamma}$$

Equation(8) yields

$$(10) \quad h(g(x)) = h(x)$$

Let us compute the iterates of  $g$ . We write (9) in a different way

$$g(x) = x + (\gamma-1)(x-h(x))$$

Therefore, using (10)

$$\begin{aligned} g^2(x) &= g(g(x)) = g(x) + (\gamma-1)(g(x) - h(x)) \\ &= x + (\gamma-1)[x - h(x) + x + (\gamma-1)(x - h(x)) - h(x)] \\ &= x + (\gamma^2-1)(x-h(x)) \end{aligned}$$

We use induction. Let us suppose for  $n \geq 0$  (with  $g^0(x) = x$ ) that

$$(11) \quad g^n(x) = g(g^{n-1}(x)) = x + (\gamma^n-1)(x-h(x))$$

Then

$$g^{n+1}(x) = x + (\gamma-1)(x-h(x)) + (\gamma^n-1)[x + (\gamma-1)(x-h(x)) - h(x)]$$

$$g^{n+1}(x) = x + (\gamma^{n+1}-1)(x - h(x))$$

and the validity of Equation (11) is proved. Moreover,  $g$  is one-to-one because from  $g(x_1) = g(x_2)$ , we deduce (Equation (10)) that  $h(x_1) = h(x_2)$ , which implies  $x_1 = x_2$  as

$$g(x_1) - \gamma x_1 = g(x_2) - \gamma x_2 = g(x_1) - \gamma x_2$$

From Equation (11), we deduce letting  $n$  grow

$$\lim_{n \rightarrow \infty} g^n(x) = h(x)$$

Using now the continuity of  $h$ , as deduced from the continuity of  $g$  and Equation (10), we get for all  $x$  in  $G$

$$(12) \quad h^2(x) = h(x)$$

Let  $I = [x | x \in G, h(x) = x]$ . The subset  $I$  is not empty (Equation (12)) and is a closed subset of  $G$ . Moreover, on  $I$ ,  $g(x) = x$ . Therefore, let  $S_x = [y | y \in G, h(y) = x]$  for every  $x$  in  $I$ . Every  $S_x$  is a non empty closed subset of  $G$  and we easily noticed that

$$(i) \quad S_x \cap I = [x]$$

as well as

$$(ii) \quad S_x \cap S_{x'} = \emptyset \text{ if } x \neq x'$$

If  $y \in S_x$ ,  $h(\gamma y + (1-\gamma)x) = h(\gamma y + (1-\gamma)h(y))$

$$= h(g(y))$$

$$= h(y) \quad \text{due to Equation (10)}$$

Therefore we get

$$(iii) \quad \gamma y + (1-\gamma)x \in S_x \text{ for all } y \in S_x.$$

(iv)  $G = \bigcup_{x \in I} S_x$  is obvious from the definition of  $I$ . We have thus proved

that  $[S_x]_{x \in I}$  is a regular iterative  $\gamma$ -decomposition of  $G$  and this ends the proof of Theorem 6.2. The problem of solving Equation (8) with  $0 < \gamma < 1$  is now reduced to the finding of all regular iterative  $\gamma$ -decompositions of  $G$ . Two problems can be posed and both are still open in general.

**Problem 1** Let  $G$  be a real Hausdorff topological linear space and  $[S_x]_{x \in I}$  a regular iterative convex decomposition of  $G$ . Is  $S_x$  necessarily either point  $[x]$  or a cone with  $x$  as its vertex? In other words, is  $\gamma$ ,  $0 < \gamma < 1$ , irrelevant in the definition of a regular iterative convex decomposition? (See Corollary 6.1).

**Problem 2** Let  $G$  be a real Hausdorff topological linear space and  $I$  be a topological retract of  $G$ . Does there exist for  $G$  an iterative convex decomposition  $[S_x]_{x \in I}$ ?

We shall now investigate Equation (8) for other values of  $\gamma$ .

**Theorem 6.3** Let  $\gamma > 1$  and let  $G$  be a real Hausdorff topological linear space. A surjective and continuous  $g: G \rightarrow G$  satisfies the equation (8)

$$(8) \quad g(g(x)) = (\gamma+1)g(x) - \gamma x \quad \text{for all } x \text{ in } G$$

if and only if there exists for  $G$  a regular  $\gamma$ -decomposition  $[S_x]_{x \in I}$  which is too a  $\gamma^{-1}$ -decomposition such that  $h(x) = \frac{g(x) - \gamma x}{1 - \gamma}$ .

The sufficiency is proved in the same way as in Theorem 6.2. For the necessity we may obtain as well Equation (10) and Equation (11). For a positive integer  $n$ , let us define  $g_n: G \rightarrow G$  by

$$g_n(x) = x + (\gamma^{-n} - 1)(x - h(x))$$

We compute

$$\begin{aligned} g_n(g^n(x)) &= g^n(x) + (\gamma^{-n} - 1)(g^n(x) - h(x)) \quad \text{due to Equation (10)} \\ &= \gamma^{-n}(g^n(x) + (\gamma^n - 1)h(x)) \\ &= \gamma^{-n}(x + (\gamma^n - 1)x) \\ &= x \end{aligned}$$

This is a new way of proving that  $g$  is one-to-one. But by our hypothesis,  $g$  is surjective, and so we deduce that  $g^{-1}(x) = g_{-1}(x)$  and more generally  $g^{-n}(x) = g_{-n}(x)$  for all positive integers  $n$ . Equation (11) is now true for all integers  $n$ . As  $\gamma > 1$ ,

$$\lim_{n \rightarrow -\infty} g_n(x) = h(x)$$

and so we also get Equation (12).

$$h^2(x) = h(x).$$

We end the proof as in the case of Theorem 6.2. However we have something more than (iii). In fact  $h(g^{-1}(x)) = h(x)$ , that is  $h(x + (\gamma^{-1} - 1)(x - h(x))) = h(x)$ . Therefore, if  $y \in S_x$ ,  $h(\gamma^{-1}y + (1 - \gamma^{-1})x) = x$ . In other words  $[S_x]_{x \in I}$  is both a  $\gamma$ -decomposition and a  $\gamma^{-1}$ -decomposition.

**Corollary 6.2** Let  $\gamma > 1$ . A continuous  $g: \mathbb{R} \rightarrow \mathbb{R}$  satisfies

$$(8) \quad g(g(x)) = (\gamma+1)g(x) - \gamma x \quad \text{for all } x \text{ in } \mathbb{R}$$

if and only if  $g$  has one of the forms given in Corollary 6.1.

Applying Theorem 6.3 to  $\mathbb{R}$ , it only remains to prove that  $g$  is always surjective. We have already noticed that  $g$  was one to one. As  $g$  is

continuous,  $g$  is strictly monotone. Let  $\alpha = \lim_{x \rightarrow +\infty} g(x)$  and  $\beta = \lim_{x \rightarrow -\infty} g(x)$ .

Equation (8) yields that  $\lim_{x \rightarrow \infty} \gamma x = (\gamma+1)\alpha - g(\alpha)$  and  $\lim_{x \rightarrow -\infty} \gamma x = (\gamma+1)\beta - g(\beta)$ . Therefore  $\alpha$  and  $\beta$  cannot be finite and the range of  $g$  is  $\mathbb{R}$ .

As an example, for Theorem 6.3, let  $G$  be a divisible abelian topological group.

Let  $H$  be a closed subgroup and suppose there exists a continuous lifting

$\xi: G/H \rightarrow G$  where  $G/H$  has the quotient topology (Chapter III §2). Let us

consider  $g: G \rightarrow G$

$$(13) \quad g(x) = 2x - \xi(\pi_H(x))$$

where  $\pi_H$  is the quotient mapping. Then  $g: G \rightarrow G$  satisfies Equation (8)

with  $\gamma = 2$  and so  $f(x) = g(x) - x$  satisfies Equation (7) with  $\gamma = 2$ .

Here  $I = \xi(G/H)$  and  $S_x = x + H$  for all  $x$  in  $I$ . In fact we get more for  $f$ , in the sense that the following functional equation is satisfied.

$$(14) \quad f(x+f(y)) = f(x) + f(y) \quad \text{for all } x, y \text{ in } G$$

We shall see (§5) that all continuous solutions of Equation (14) have

the form  $x - \xi(\pi_H(x))$ . A function defined according to (13) is

surjective if and only if for every  $y$  in  $G$ , there exists  $x$  and

$2x = y$  (for example if  $G$  is divisible). Proofs of Theorems 6.2 and

6.3 can easily be adapted to the case  $-1 < \gamma < 0$  and  $\gamma < 1$  as well.

As special cases of interest, there remains  $\gamma = 1$  (linked to Euler's

equation),  $\gamma = 0$  (idempotence) and  $\gamma = -1$  (involution). We summarize

all results on  $\mathbb{R}$  in one theorem. We say that  $g: \mathbb{R} \rightarrow \mathbb{R}$  is of type

$(\gamma, a, b)$ , for  $-\infty \leq a < b \leq +\infty$  if

$$g(x) = \begin{cases} \gamma x + (1-\gamma)a & \text{for } x < a \\ x & \text{for } a \leq x \leq b \\ \gamma x + (1-\gamma)b & \text{for } x > b \end{cases}$$

and of type  $(\gamma, \delta)$ ; for  $\delta \in \mathbb{R}$ , if

$$g(x) = \gamma x + \delta$$

Theorem 6.4 The complete set of continuous solutions  $g: \mathbb{R} \rightarrow \mathbb{R}$  of the functional equation

$$(8) \quad g(g(x)) = (\gamma+1)g(x) - \gamma x \quad \text{for all } x \text{ in } \mathbb{R}$$

is given by

a) If  $\gamma > 0, \gamma \neq 1$  type  $(\gamma, a, b)$  and type  $(\gamma, \delta)$

b) If  $\gamma < 0, \gamma \neq -1$  type  $(\gamma, \delta)$  and  $g(x) \equiv x$  (type  $(\gamma, -\infty, +\infty)$ )

c) If  $\gamma = 1$  type  $(1, \delta)$

d) If  $\gamma = 0$  type  $(0, \delta)$  and for  $-\infty \leq a < b \leq +\infty$

$g(x) = x$  for  $x \in [a, b]$ ,  $g(x) \in [a, b]$  for  $x \notin [a, b]$

e) If  $\gamma = -1$   $g(x) \equiv x$  and for any  $c \in \mathbb{R}$ ; any strictly

decreasing and continuous  $\phi = ]-\infty, c] \rightarrow \mathbb{R}$ , such that  $\lim_{x \rightarrow -\infty} \phi(x) = +\infty$ ,

$\phi(c) = c$ , we get  $g(x) = \phi(x)$  for  $x \in ]-\infty, c]$ ,  $g(x) = \phi^{-1}(x)$  for  $x \in ]c, +\infty[$ .

Proof

a) Corollary 6.1 and Corollary 6.2

b) We prove as in Corollary 6.2, that  $g$  is a bijection from  $\mathbb{R}$  onto  $\mathbb{R}$ . We now follow the proof of Corollary 6.1. To prove b) we have to show

that either  $I = \mathbb{R}$  or  $I$  is reduced to one point. Suppose for example

that  $b < \infty$  and  $a < b$ . Let  $y \in S_b$ . Then  $y_1 = \gamma y + (1-\gamma)b \in S_b$  and

$y_2 = \gamma^{-1}y + (1-\gamma^{-1})b \in S_b$ . But  $y_1 - b = \gamma(y-b)$  and  $(y_2 - b) = \gamma^{-1}(y-b)$ .

Depending on the choice of  $y_1, y_2$  and whether  $\gamma < -1$  or  $-1 < \gamma < 0$ ,

we are approaching  $b$ . But  $]a, b[ \cap S_b = \emptyset$ . This is a contradiction and case b) is proved.

c) With  $f(x) = g(x) - x$ , we get for  $f$  the Euler equation (7) with  $\gamma = 1$ . As in Corollary 6.2, we prove that  $g$  is one-to-one and surjective.

It is therefore a strictly monotone function. Moreover, by induction, we

see that  $g^n(x) = x + n f(x)$  for any positive integer  $n$ . With

$g_{-n}(x) = x - n f(x)$ , we deduce that  $g_{-n}(g^n(x)) = x$ . Therefore, for

all integers  $n$ ,  $g^n(x) = x + n f(x)$ . Two cases are to be studied.

Either  $f(x) \equiv 0$  and so  $g(x) \equiv x$  which is type  $(1,0)$ , or there exists

an  $x_0$  in  $\mathbb{R}$  and  $f(x_0) \neq 0$ . Any point  $x$  in  $\mathbb{R}$  belongs to an

interval with endpoints  $x_0 + h f(x_0) = g^h(x_0)$  and  $x_0 + h' f(x_0) = g^{h'}(x_0)$

for some integers  $h, h'$ . Using the monotony of  $g^n$ , we deduce that for

all  $n$ ,  $\frac{1}{n} g^n(x)$  belongs to an interval with extremities  $\frac{x_0}{n} + \frac{(h+n)}{n} f(x_0)$ ,  $\frac{x_0}{n} + \frac{(h'+n)}{n} f(x_0)$ . Letting  $n$  go to infinity, we deduce immediately that

$\lim_{n \rightarrow \infty} \frac{1}{n} g^n(x) = f(x) = f(x_0)$ . Therefore,  $f$  is a constant function and  $g$

is of type  $(1, \delta)$  for some  $\delta$  in  $\mathbb{R}$ .

d) Let  $I = \{x \mid g(x) = x\}$ . It is a non-empty closed subset of  $\mathbb{R}$ . As  $g^2 = g$ ,  $I$  is the image of  $g$  and so  $I$  is connected. If  $I = [\delta]$ , then  $g(x) \equiv \delta$  which is of type  $(0, \delta)$ . If  $I = [a, b]$  with  $a < b$ , we easily get the form as stated in the Theorem. (Replace for example "[a" by "]- $\infty$ ", if  $a = -\infty$ ).

e) This is the involution case and in contrast with all the previous cases, the general solution depends upon an arbitrary strictly decreasing and continuous function.

First, it is clear that a continuous solution of  $g(g(x)) = x$  is a bijection, therefore continuous and either strictly increasing or strictly decreasing.

Suppose  $g$  is strictly increasing and let  $x \in \mathbb{R}$  such that  $g(x) \neq x$ . Two

cases occur. If  $g(x) < x$ , then a fortiori  $g(g(x)) < g(x) < x$  which is impossible and if  $g(x) > x$ , then a fortiori  $g(g(x)) > g(x) > x$  which is

impossible as well. Therefore, for all  $x$  in  $\mathbb{R}$ ,  $g(x) = x$ . Suppose now

$g$  is strictly decreasing. We must have  $\lim_{x \rightarrow -\infty} g(x) = +\infty$  as  $g$  is a

bijection. Let  $c$  be the unique real number such that  $g(c) = c$ .

Define  $\phi(x) = g(x)$  for  $x \in ]-\infty, c]$ . Let  $x > c$ . Then there exists

$y \in ]-\infty, c[$  and  $g(y) = x$  due to the properties of  $g$ . Therefore

$g(g(y)) = g(x) = y$ . In other words,  $g(x) = \phi^{-1}(x)$ , where the notation

$\phi^{-1}: [c, +\infty[ \rightarrow ]-\infty, c[$  denotes the continuous inverse function of

$\phi: ]-\infty, c] \rightarrow [c, +\infty[$ .

Conversely, it is easy to show that functions  $g(x) = x$  and  $g$  deduced from  $\phi$  in the stated manner, are solutions of  $g(g(x)) = x$ . This ends the proof of Theorem 6.4.

## 6.3 Application: Another Characterization of Inner Product Spaces

Theorem 6.5 Let  $E$  be a real or complex normed space. Suppose that for all  $x, y$  in  $E$  such that  $\|x\| = \|y\|$ , the following equation holds for all real  $\lambda, \mu$

$$(1) \quad \|\lambda x + \mu y\| = \|\mu x + \lambda y\|.$$

Then the norm of  $E$  arises from an inner product.

Recall that an inner product on a linear space  $E$  is a mapping from  $E \times E$  into  $\mathbb{R}$  or  $\mathbb{C}$ , according to whether  $E$  is a real or a complex linear space, denoted by  $\langle x, y \rangle$  and such that

$$\left\{ \begin{array}{l} \langle x, y \rangle = \langle y, x \rangle \text{ in the real case; } \langle x, y \rangle = \overline{\langle y, x \rangle} \text{ in the complex case} \\ \langle x, x \rangle \geq 0 \text{ and } \langle x, x \rangle = 0 \text{ if and only if } x = 0 \\ \langle x_1 + x_2, y \rangle = \langle x_1, y \rangle + \langle x_2, y \rangle \text{ for all } x_1, x_2 \text{ and } y \text{ in } E \\ \langle \lambda x, y \rangle = \lambda \langle x, y \rangle \text{ for all } \lambda \text{ in } \mathbb{R} \text{ (or in } \mathbb{C} \text{ in the complex case),} \\ \text{and all } x, y \text{ in } E \end{array} \right.$$

"The norm of  $E$  arises from an inner product" means that there exists an inner product  $\langle, \rangle$  such that for all  $x$  in  $E$

$$\|x\| = \sqrt{\langle x, x \rangle}$$

a) If the norm of  $E$  comes from an inner product space  $E$ , then

$$\begin{aligned} \|\lambda x + \mu y\|^2 &= \lambda^2 \langle x, x \rangle + 2\lambda\mu \operatorname{Re} \langle x, y \rangle + \mu^2 \langle y, y \rangle \\ &= (\lambda^2 + \mu^2) \frac{\|x\|^2 + \|y\|^2}{2} + 2\lambda\mu \operatorname{Re} \langle x, y \rangle \\ &= \|\mu x + \lambda y\|^2 \end{aligned}$$

Therefore we get Eq (1).

b) Conversely, let us define a function  $g: E \rightarrow \mathbb{R}$  according to

$$(2) \quad g(x) = \|x\|^2$$

If Eq (1) is satisfied, we compute for  $x, y$  in  $E$

$$g(g(x)y + g(y)x) = \left\| \|x\|^2 y + \|y\|^2 x \right\|^2$$

which we write, if  $x \neq 0$  and  $y \neq 0$ , as

$$g(g(x)y + g(y)x) = \|x\|^2 \|y\|^2 \left\| \|x\| \frac{y}{\|y\|} + \|y\| \frac{x}{\|x\|} \right\|^2$$

With the help of Eq (1), it becomes

$$g(g(x)y + g(y)x) = \|x\|^2 \|y\|^2 \|y+x\|^2 = g(x)g(y)g(x+y)$$

The last equation is also valid for  $x = 0$  as for  $y = 0$ . We thus get a functional equation

$$(3) \quad g(g(x)y + g(y)x) = g(x)g(y)g(x+y)$$

We now proceed to solve Eq (3), using from the definition of  $g$  the only supplementary remarks

$$g(0) = 0 \quad \text{and} \quad g(x) > 0 \quad \text{for all } x \neq 0 \text{ in } E$$

We first notice that Eq (3) involves only two dimensional real subspaces of  $E$ . Therefore, it is wise to first solve (3) for  $g: \mathbb{R}^2 \rightarrow \mathbb{R}$ . In such a case, a new functional equation arises as

Lemma 6.1 Let  $g: \mathbb{R}^2 \rightarrow \mathbb{R}$  be such that  $g(0) = 0$ ,  $g(z) > 0$  for all non zero  $z$  in  $\mathbb{R}^2$  and  $\lim_{z \rightarrow \infty} g(z) = +\infty$ . Suppose  $g$  to be a continuous solution of (3) for all  $x, y$  in  $\mathbb{R}^2$ . Then  $g$  also satisfies for all  $x, y$  in  $\mathbb{R}^2$ .



$$(4) \quad g(x+y) + g(x-y) = 2(g(x)+g(y))$$

Once Lemma 6.1 is proved, we can deduce that  $g: E \rightarrow \mathbb{R}$  satisfies (4) for all  $x, y$  in  $E$ . But Eq (4) can be solved in such a structure with a regularity assumption on  $g$  which is weaker than continuity.

Lemma 6.2 Let  $E$  be a real linear space. Let  $g: E \rightarrow \mathbb{R}$  such that  $g(0) = 0$ ;  $g(x) > 0$  for all  $x \neq 0$  in  $E$ . Suppose that for all  $x \neq 0$  in  $E$ , there exists a subset  $I_x$  of  $\mathbb{R}$ , of positive Lebesgue measure and a constant  $M_x$  such that  $g(\lambda x) \leq M_x$  for all  $\lambda$  in  $I_x$ . If  $g$  is a solution of (4), for all  $x, y$  in  $E$ , there exists an inner product  $\langle, \rangle$  and for all  $x$  in  $E$

$$g(x) = \langle x, x \rangle$$

Proof of Lemma 6.2 Let  $g: E \rightarrow \mathbb{R}$  satisfy the functional equation (4) where  $E$  is a real linear space. We then define  $f: E \times E \rightarrow \mathbb{R}$  according to

$$(5) \quad f(x, y) = \frac{1}{4}[g(x+y) - g(x-y)]$$

Let us compute  $4(f(x_1+x_2, y) + f(x_1-x_2, y))$  by conveniently grouping terms and using Eq (4)

$$\begin{aligned} 4(f(x_1+x_2, y) + f(x_1-x_2, y)) &= g(x_1+x_2+y) + g(x_1-x_2+y) - g(x_1+x_2-y) - g(x_1-x_2-y) \\ &= 2(g(x_1+y) + g(x_2) - g(x_1-y) - g(x_2)) \\ &= 2(g(x_1+y) - g(x_1-y)) \\ &= 8f(x_1, y) \end{aligned}$$

With  $X = x_1 + x_2$  and  $Y = x_1 - x_2$ , we deduce that

$$(6) \quad f(X, y) + f(Y, y) = 2f\left(\frac{X+Y}{2}, y\right)$$

With  $x = x_1 = x_2$ , we deduce that

$$(7) \quad f(2x, y) + f(0, y) = 2f(x, y)$$

From (4), we deduce that  $g(x-y) = g(y-x)$  and that  $f$  is symmetric in  $x$  and  $y$ . By the definition of  $f$ ,  $f(x, 0) = 0$  and by symmetry  $f(0, x) = 0$ . Accordingly, (7) yields  $f(2x, y) = 2f(x, y)$ , which with (6) gives us:

$$f(X, y) + f(Y, y) = f(X+Y, y)$$

Now define, for every pair  $x, y$  of elements in  $E$ , a function  $h: \mathbb{R} \rightarrow \mathbb{R}$

$$h(\lambda) = f(\lambda x, y)$$

Clearly  $h$  is an additive function. For  $\lambda$  belonging to the subset  $I_x$ , as provided by our hypothesis, we compute, with the help of Eq (4) and the sign of  $g$ :

$$4h(\lambda) = 2(g(\lambda x+y) - g(\lambda x) - g(y)) \geq -2g(\lambda x) - 2g(y) \geq -2M_x - 2g(y)$$

Theorem 1.2 yields the continuity of  $h$  and so  $f(\lambda x, y) = \lambda f(x, y)$  for all  $\lambda$  in  $\mathbb{R}$ . To summarize, we have proved that  $f(x, y)$  defines an inner product in the (real) linear space  $E$ .

To conclude with the proof of Lemma 6.2, it is enough to notice from Eq (4) that  $g(0) = 0$  and  $g(2x) = 4g(x)$ . Therefore  $f(x, x) = \frac{1}{4}g(2x) = g(x)$ .

Proof of Theorem 6.5 When  $E$  is a real normed space, Lemma 6.2 ends the proof (modulo that, which shall come soon, of Lemma 6.1).

When  $E$  is a complex normed space, we first consider it as a real linear space. Therefore, we still have  $f(x, y)$  as a real inner product on  $E$  considered as a real linear space. But the function  $g$ , defined by Eq (2), satisfies  $g(\lambda x) = |\lambda|^2 g(x)$  for all  $\lambda$  in  $\mathbb{C}$ ; so we define for  $x, y$  in  $E$



$$F(x,y) = f(x,y) - if(ix,y)$$

For each pair  $(x,y)$ ,  $F(x,y)$  is a complex number. It satisfies the axioms of a complex inner product

$$F(x_1+x_2,y) = F(x_1,y) + F(x_2,y) \quad \text{for all } x_1, x_2 \text{ and } y \text{ in } E$$

$$F(\lambda x,y) = \lambda F(x,y) \quad \text{for all } \lambda \text{ in } \mathbb{C}, \text{ and } x, y \text{ in } E$$

(as can be verified by a simple computation)

$F(x,x) \geq 0$  and is zero only if  $x = 0$  (From  $g(\lambda x) = |\lambda|^2 g(x)$ , we compute that  $f(ix,x) = 0$  using Eq (4) and so  $F(x,x) = f(x,x)$ ).

$$F(x,y) = \overline{F(y,x)} \quad (\text{From } f(ix,y) = -f(x,iy))$$

which can be deduced from Eq (4), using  $g(ix) = g(x)$ ,  $g(-x) = g(x)$ .

Moreover  $F(x,x) = f(x,x) = g(x)$ .

With lemma 6.2 and what we just proved above, we deduce that the norm of a real or complex linear normed space arises from an inner product space if every two dimensional real subspace is Euclidean. This is the classical result due to P. Jordan and J. von Neumann.

For the proof of Lemma 6.1, we need another lemma, giving the solutions of Eq (3) in  $\mathbb{R}$ .

Lemma 6.3 Let  $g: \mathbb{R} \rightarrow \mathbb{R}$  be a continuous function such that  $g(0) = 0$ ,  $g(x) > 0$  for all  $x \neq 0$  and  $\lim_{x \rightarrow \infty} g(x) = +\infty$ . Suppose  $g$  is a solution of the functional equation (3)

$$(3) \quad g(g(x)y + g(y)x) = g(x)g(y)g(x+y) \quad \text{for all } x, y \text{ in } \mathbb{R}.$$

There exists a positive constant  $a$ ,  $a > 0$ , such that  $g(x) = ax^2$  for all  $x$  in  $\mathbb{R}$ .

Proof With  $y = -x$  in Eq (3), we deduce that  $g(-xg(x) + g(-x)x) = 0$ , and as  $g(x) \neq 0$  for  $x \neq 0$ , we get that  $g$  is an even function.

$$\text{With } F(x) = xg\left(\frac{x}{2}\right) \text{ and } h(x) = \frac{g(x)}{x^2} \text{ for } x \neq 0, \text{ Eq (3)}$$

yields

$$(8) \quad h(F(x)) = h(x) \quad \text{for } x \neq 0.$$

Once more, we meet a functional equation of the form (8). (See Eq (6) in §1 and Eq (10) in §2). This time, the solution will depend heavily upon the fact that the variable lies in  $\mathbb{R}$ .

As  $g(0) = 0$  and  $\lim_{x \rightarrow \infty} g(x) = +\infty$ , we deduce that there exists a largest

$X_0 \geq 0$  such that  $F(X_0) = X_0$ . Moreover  $F(x) > x$  for all  $x > X_0$ .

Take an arbitrary  $x_0 \geq X_0$ . As  $F(X_0) = X_0$  and  $\lim_{x \rightarrow \infty} F(x) = +\infty$ , we may

find at least one  $x_1, x_1 \geq X_0$  such that  $F(x_1) = x_0$ . Clearly  $x_1 \leq x_0$ .

Repeating the process, we get a sequence  $[x_n]_{n \geq 1}$ , with  $X_0 \leq x_{n+1} \leq x_n$

and  $F(x_{n+1}) = x_n$ . Therefore  $\lim_{n \rightarrow \infty} x_n = x_\infty$  exists. But the continuity of

$F$  yields  $F(x_\infty) = x_\infty$  and so by definition of  $X_0$ ,  $x_\infty = X_0$ .

Repeated application of Equation (8) now yields  $h(x_0) = h(F(x_1)) = h(x_1) = h(F(x_2))$

$= h(x_2) = \dots = h(x_n)$ . By the continuity of  $h$ ,  $h(x_0) = h(X_0)$ . But  $x_0$

was arbitrarily chosen, larger than or equal to  $X_0$ . Therefore  $h$  is

constant on  $[X_0, \infty[$ . It means  $g(x) = h(X_0)x^2$  for all  $x \geq X_0$ . We

may apply Eq (3) with  $x \geq X_0$  and an arbitrary  $y \geq 0$ . As we have

$\lim_{x \rightarrow \infty} (g(x)y + g(y)x) = +\infty$ , we may find an  $x_0$  large enough so that

$g(x_0)y + g(y)x_0 \geq X_0$  for all  $y \geq 0$  and  $g(x_0) = h(X_0)x_0^2$ . Therefore

$$h(X_0)[h(X_0)x_0^2y + g(y)x_0]^2 = h(X_0)x_0^2g(y)h(X_0)(x_0+y)^2$$

Developing this expression we get

$$(g(y))^2 - x_0 h(x_0)(x_0^2 + y)g(y) + (h(x_0))^2 x_0^2 y^2 = 0$$

The discriminant being  $x_0^2(h(x_0))^2(x_0^2 - y)^2$ , and  $y$  being arbitrary, we easily deduce that  $g(y) = h(x_0)y^2$  for all  $y \geq 0$ . Due to the evenness of  $g$ , this ends the proof of Lemma 6.3.

Proof of Lemma 6.1 Eq (3) looks harder to solve in  $\mathbb{R}^2$  than in  $\mathbb{R}$ , as it does not seem possible to deduce from it, in this case, a functional equation of the type (8). However, with the help of Lemma 6.3, we already get  $g(\lambda z) = \lambda^2 g(z)$  for any  $z$  in  $\mathbb{R}^2$  and  $\lambda$  in  $\mathbb{R}$ . Using  $z, t$  in  $\mathbb{R}^2$  (complex numbers), we write Eq (4) as

$$(9) \quad g(z+t) = g(z)g(t)g\left(\frac{z}{g(z)} + \frac{t}{g(t)}\right)$$

Now, the idea is to get a similar functional equation for the periodic (period  $\pi$ )  $h: \mathbb{R} \rightarrow ]0, \infty[$

$$g(z) = |z|^2 h(\text{Arg } z)$$

A somewhat long computation (see bibliography for details), based on the equation for  $h$  deduced from (9), leads to

$$g(z) = g(x+iy) = g_1(x) + g_2(y) \quad x, y \in \mathbb{R}$$

where both  $g_1$  and  $g_2$  are defined over  $\mathbb{R}$ , strictly positive except at 0, continuous, such that  $\lim_{x \rightarrow \infty} g_1(x) = \lim_{y \rightarrow \infty} g_2(y) = +\infty$  and

both satisfying Eq (3).

Lemma 6.3 then yields

$$\begin{aligned} g(z+z') + g(z-z') &= g_1(x+x') + g_1(x-x') + g_2(y+y') + g_2(y-y') \\ &= 2(g_1(x) + g_1(x')) + 2(g_2(y) + g_2(y')) \\ &= 2(g_1(x) + g_2(y)) + 2(g_1(x') + g_2(y')) \\ &= 2(g(z) + g(z')) \end{aligned}$$

which ends the proof of lemma 6.1.

From Theorem 6.5, we may deduce an interesting geometrical characterization.

Theorem 6.6 Let  $E$  be a real or complex normed space such that the lengths of the side of any triangle in  $E$  determine the lengths of the medians.

Then the norm of  $E$  arises from an inner product.

Proof The geometric property that the lengths of the side of any triangle in  $E$  determine the lengths of the medians can be analytically interpreted as saying there exists some function  $L: (\mathbb{R}^+, \mathbb{R}^+, \mathbb{R}^+) \rightarrow \mathbb{R}^+$  such that

$$||x+y|| = L(||x||, ||y||, ||x-y||) \quad \text{for all } x, y \text{ in } E$$

The function  $L$  satisfies enough combinatorial functional equations to yield the theorem. For example, let  $x, y \in E$  with  $||x|| = ||y||$ .

$$\begin{aligned} ||2x+y|| &= ||(x+y)+x|| = L(||x+y||, ||x||, ||y||) \\ &= L(||x+y||, ||y||, ||x||) \\ &= ||x+2y|| \end{aligned}$$

We prove by induction that  $||hx+y|| = ||x+hy||$  whenever  $||x|| = ||y||$  for all positive integers  $h$ .

$$\begin{aligned} ||hx+y|| &= ||(h-1)x+y+x|| = L(||(h-1)x+y||, ||x||, ||(h-2)x+y||) \\ &= L(||x+(h-1)y||, ||y||, ||x+(h-2)y||) \\ &= ||x+(h-1)y+y|| \\ &= ||x+hy||. \end{aligned}$$

Define  $\Gamma = [\gamma | \gamma \in \mathbb{R}: ||x+\gamma y|| = ||\gamma x+y|| \text{ for all } x, y \text{ in } E \text{ such that } ||x|| = ||y||]$ .

Clearly  $0 \in \Gamma$ ,  $\gamma^{-1} \in \Gamma$  if  $0 \neq \gamma \in \Gamma$  and  $-\gamma \in \Gamma$  if  $\gamma \in \Gamma$ . Let  $\gamma_1, \gamma_2$  in  $\Gamma$  satisfy  $\gamma_1 \gamma_2 \neq -1$ . Then  $\frac{\gamma_1 + \gamma_2}{1 + \gamma_1 \gamma_2} \in \Gamma$ . To see this we

compute as follows ( $||\gamma_1 x + y|| = ||x + \gamma_1 y||$  for  $||x|| = ||y||$ ).

$$||(\gamma_1 x + y) + \gamma_2(\gamma_1 x + y)|| = ||\gamma_2(\gamma_1 x + y) + (\gamma_1 x + y)||$$

Therefore

$$||(\gamma_1 + \gamma_2)x + (\gamma_1 + \gamma_2)y|| = ||(\gamma_1 + \gamma_2)x + (1 + \gamma_1 \gamma_2)y||$$

Let  $\gamma_1, \gamma_2$  in  $] -1, +1[$  and set  $x_1 = \text{Arctanh } \gamma_1$ ,  $x_2 = \text{Arctanh } \gamma_2$ .

We get

$$\frac{\gamma_1 + \gamma_2}{1 + \gamma_1 \gamma_2} = \tanh(x_1 + x_2)$$

Therefore with  $\Gamma' = [\gamma' | \gamma' = \text{Arctanh } \gamma; \gamma \in ] -1, +1[, \gamma \in \Gamma]$  we deduce that  $\Gamma'$  is a subgroup of  $\mathbb{R}$ . It is a closed subgroup of  $\mathbb{R}$  as  $\Gamma$  is a closed subset of  $\mathbb{R}$ . Therefore either  $\Gamma' = \mathbb{R}$  or there exists  $\gamma_0' \in \mathbb{R}$  and  $\Gamma' = \gamma_0' \mathbb{Z}$ . To prove that the second case is impossible it is enough to notice that  $\frac{1}{h} \in \Gamma$  and so  $\text{Arctanh } \frac{1}{h} \in \Gamma'$  whenever  $h$  is a non zero integer. We then deduce that  $\Gamma = \mathbb{R}$  and so Theorem 6.5 yields Theorem 6.6.

#### 6.4 A Functional Equation in the Theory of Geometrical Objects

It is always an important problem to determine all subgroups of a given continuous group of transformations. The classical method of S. Lie presupposes strong regularity. The straightforward method of functional equations can bring some insight, involving less regularity assumptions. As a very simple example, let  $g$  be the group of affine transformations of the real line

$$T \in g \text{ if } T(x) = \alpha x + \beta \quad (\alpha \neq 0) \quad \alpha, \beta \in \mathbb{R}$$

We look for one parameter subsemigroups  $G$  of  $g$ :

$$T_u \in G \quad T_u(x) = \alpha(u)x + \beta(u) \quad u \in \mathbb{R}, \text{ i.e. such that}$$

for  $u, v$  in  $\mathbb{R}$ , there must exist  $w$  in  $\mathbb{R}$  and

$$(1) \quad T_w = T_u \circ T_v$$

Then

$$(2) \quad \alpha(w) = \alpha(u)\alpha(v)$$

and

$$(3) \quad \beta(w) = \alpha(u)\beta(v) + \beta(u)$$

Suppose that  $\beta: \mathbb{R} \rightarrow \mathbb{R}$  is one-to-one. We define  $x = \beta(u)$  and  $f(x) = \alpha(\beta^{-1}(x))$ . Eq (2) and (3) yield, for  $x, y$  in the range of  $\beta$ , a functional equation of a new type

$$(4) \quad f(x + yf(x)) = f(x)f(y)$$

A function like  $x \rightarrow 1 + ax$ ,  $a \in \mathbb{R}$ , is a continuous solution of Eq (4).

The Dirichlet function, equal to 0 for irrational  $x$  and 1 for rational  $x$

is a (non-continuous) solution of Eq (4). Let now  $g: \mathbb{R} \rightarrow \mathbb{R}$  be a discontinuous additive function (hence non Lebesgue measurable: cf Chapter IV) and define  $f(x) = 1 + g(x)$ . The function  $f$  satisfies Eq (4) if and only if  $g(yg(x)) = g(x)g(y)$  for all  $x, y$  in  $\mathbb{R}$ . By Theorem 4.6, we may find a discontinuous additive  $g$  defined on  $\mathbb{R}$  and taking its values in  $\mathbb{Q}$ . In such a case,  $g(yg(x)) = g(x)g(y)$  is satisfied. Therefore (4) holds for very irregular solutions. Eq (4) also appears when looking, in the same way, for the three parameter subgroups of the centro-affine group of the plane, or in the theory of geometrical objects (cf bibliography).

Eq (4) is a functional equation of two variables with superposition of the unknown function. Its general solution on a linear space over a commutative field  $F$  is known, but in a rather unpractical way.

Theorem 6.7 Let  $E$  be a linear space over a commutative field  $K$ . Let  $f: E \rightarrow K$  and suppose  $f$  is not identically zero. This function satisfies the equation

$$(4) \quad f(x+yf(x)) = f(x)f(y) \quad \text{for all } x, y \text{ in } E$$

if and only if there exists an additive subgroup  $F$  of  $E$ , a multiplicative subgroup  $\Lambda$  of  $K \setminus \{0\}$  and a function  $\zeta: \Lambda \rightarrow E$  such that

- a)  $\lambda x \in F$  for all  $\lambda \in \Lambda, x \in F$ . Conversely if  $y \in F, \lambda \in \Lambda$ , there exists  $x \in F$  such that  $\lambda x = y$ .
- b)  $\zeta(\lambda) \in F$  if and only if  $\lambda = 1$
- c)  $\zeta(\lambda_1 \lambda_2) = \zeta(\lambda_1) + \lambda_1 \zeta(\lambda_2) \in F$  for all  $\lambda_1, \lambda_2 \in \Lambda$

$$\begin{aligned} d) \quad f(x) &= \lambda \quad \text{if } x \in \zeta(\lambda) + F \\ f(x) &= 0 \quad \text{if } x \notin \bigcup_{\lambda \in \Lambda} (\zeta(\lambda) + F) \end{aligned}$$

Proof Suppose  $f$  is a solution of Eq (4),  $f: E \rightarrow K$ , and suppose  $f$  is not identically zero. Let  $G$  be the set of all  $x$  in  $E$ , such that  $f(x) \neq 0$ , and let  $F$  be the set of all  $x$  in  $E$ , such that  $f(x) = 1$ . First step  $(G, \circ)$  is a group, where  $\circ$  is the binary operation:

$$x \circ y = x + yf(x)$$

As  $f(x \circ y) = f(x)f(y) \neq 0$ ,  $x \circ y$  is a binary operation within  $G$ . From (4), we deduce that  $f(0) = 1$  as  $f$  is not identically zero. Therefore  $0 \circ y = y$  and  $y \circ 0 = y$ , so that  $0$  is a neutral element of  $(G, \circ)$ . If  $x, y$  and  $z$  are in  $G$ ,  $(x \circ y) \circ z = (x + yf(x)) + zf(x + yf(x)) = x + yf(x) + zf(x)f(y) = x + f(x)[y + zf(y)] = x \circ (y \circ z)$  and so  $\circ$  is associative.

If  $x$  is in  $G$ , let  $x' = -\frac{x}{f(x)}$ . We compute  $x \circ x' = x - \frac{x}{f(x)} f(x) = 0$ . Therefore  $1 = f(0) = f(x \circ x') = f(x)f(x')$  and so  $f(x') = \frac{1}{f(x)}$ . We now compute  $x' \circ x = -\frac{x}{f(x)} + xf(x') = -\frac{x}{f(x)} + \frac{x}{f(x)} = 0$ .

Second step  $(F, +)$  is an additive subgroup of  $E$

If  $x, y$  are in  $F$ , as  $f(x) = f(y) = 1$ , then we compute  $f(x-y) = f(x-yf(x)) = f(x)f(-y)$ . But with  $x = y$ , we deduce that  $f(-y) = 1$ . Therefore  $x - y \in F$ .

Third step  $F$  is a normal subgroup of  $(G, \circ)$

Let  $x, y$  in  $F$  and put  $y' = -\frac{y}{f(y)} = -y$ . We already noticed that

$$f(xoy') = 1$$

Therefore  $F$  is a subgroup of  $(G, o)$ .

Let  $z$  in  $G$  and  $x$  in  $F$ . We compute, with  $z' = \frac{z}{f(z)}$ , that  $f(zoxoz') = f(z)f(x)f(z') = f(x) = 1$ . Therefore  $zoxoz' \in F$  for all  $z$  in  $G$  and  $x$  in  $F$ .

Let  $\Lambda = f(G)$ . It is a subset of  $K$ .

Fourth step  $\Lambda$  is a multiplicative subgroup of  $K \setminus \{0\}$ .

As  $f$  is an homomorphism from  $(G, o)$  into  $K \setminus \{0\}$ ,  $\Lambda$  is a multiplicative subgroup of  $K \setminus \{0\}$ . The kernel of this homomorphism is the normal subgroup  $(F, o)$  of  $(G, o)$ .

Fifth step Let  $y \in F$  and  $\lambda \in \Lambda$ , there exists  $x \in F$  and  $\lambda x = y$  and for all  $x$  in  $F$ ,  $\lambda x \in F$ .

As  $(F, o)$  is a normal subgroup of  $(G, o)$ , we deduce that

$$\begin{aligned} Fox &= F + xf(F) = F + x & \text{for } x \in G \\ &= xoF = x + Ff(x) \end{aligned}$$

In other words  $f(x)F = F$  for all  $x$  in  $G$ . This proves the fifth step, which is a).

The subgroup  $\Lambda$  is homomorphic (via  $f$ ) to the quotient group  $G/F$  (for the  $o$  operation). Let  $\zeta' = G/F \rightarrow G$  be a lifting relative to  $F$  (cf Chapter III, §2). It induces a lifting  $\zeta: \Lambda \rightarrow G$  relative to  $f$ , in the sense that

$$f(\zeta(\lambda)) = \lambda \quad \text{for all } \lambda \text{ in } \Lambda$$

As seen in the fifth step, each coset  $h(\lambda)oF$  is equal to  $h(\lambda) + F$  and clearly  $f(\zeta(\lambda)+F) = f(\zeta(\lambda)) = \lambda$  as well as  $f(x) = 0$  if  $x \notin G$

where  $G = \bigcup_{\lambda \in \Lambda} (h(\lambda)+F)$ , which proves d).

Therefore  $\zeta(1) \in F$ . Conversely, if  $\zeta(\lambda) \in F$ , then  $f(\zeta(\lambda)) = 1$  and so  $\lambda = 1$ , which proves b).

As  $f$  is a homomorphism from  $(G, o)$  onto  $\Lambda$ , for  $\lambda_1, \lambda_2$  in  $\Lambda$ ,  $\zeta(\lambda_1\lambda_2)$  belongs to  $(\zeta(\lambda_1)o\zeta(\lambda_2)) + F$ . In other words  $\zeta(\lambda_1\lambda_2) - [\zeta(\lambda_1)+\zeta(\lambda_2)f(\zeta(\lambda_1))] = \zeta(\lambda_1\lambda_2) - \zeta(\lambda_1) - \lambda_1\zeta(\lambda_2) \in F$  which proves c).

For the sufficiency of the Theorem 6.7, let a), b), c) and d) be satisfied and let us compute  $f(x+yf(x))$  for  $x, y$  in  $E$ .

If  $x \in \bigcup_{\lambda \in \Lambda} (\zeta(\lambda)+F)$ , then  $f(x) = 0$  and so  $f(x+yf(x)) = 0 = f(x)f(y)$ .

If  $x = \zeta(\lambda_1) + F$ , we must consider two cases. Either  $y = \zeta(\lambda_1) + F$  or  $f(y) = 0$ .

$$\begin{aligned} \text{In the first case, } x + yf(x) &= \zeta(\lambda_1) + \lambda_1\zeta(\lambda_2) + F + \lambda_1F \\ &= \zeta(\lambda_1\lambda_2) + F \end{aligned}$$

Therefore  $f(x+yf(x)) = f(\zeta(\lambda_1\lambda_2)) = \lambda_1\lambda_2 = f(x)f(y)$ .

If  $f(y) = 0$ , let us suppose that  $f(x+yf(x)) \neq 0$ , which implies the existence of a  $\lambda \in \Lambda$  such that  $x + yf(x) \in \zeta(\lambda) + F$ . Let  $\lambda_2 = \lambda/\lambda_1$ . We derive that  $yf(x) \in \zeta(\lambda) - \zeta(\lambda_1) + F$  or

$$yf(x) \in \zeta(\lambda_1) + \lambda_1\zeta(\lambda_2) - \zeta(\lambda_1) + F = \lambda_1\zeta(\lambda_2) + F$$

which yields  $\lambda_1y \in \lambda_1\zeta(\lambda_2) + F$ . But  $F = \lambda_1F$  by a), and so  $y \in \zeta(\lambda_2) + F$  which is a contradiction. Therefore  $f(x+yf(x)) = 0$  which precisely is  $f(x)f(y)$ . This ends the proof of Theorem 6.7.

We could use Theorem 6.7, plus a little bit of analysis, in order to find out all continuous solutions of the functional equation (4) when  $E$  is a topological vector space on the field  $\mathbb{R}$  or  $\mathbb{C}$ . We

could also study the Lebesgue measurable solutions of Eq (4) where  $E$  is some  $\mathbb{R}^n$  ( $n \geq 1$ ).

We shall only mention a result in the case of the real axis (see bibliography for more).

Corollary 6.3 A continuous function  $f: \mathbb{R} \rightarrow \mathbb{R}$  is for all  $x, y$  in  $\mathbb{R}$  a solution of the equation

$$(4) \quad f(x+yf(x)) = f(x)f(y)$$

if and only if  $f$  has one of the following forms

$$\begin{cases} f(x) = ax + 1 & a \in \mathbb{R} \\ f(x) = 0 & \\ f(x) = \text{Sup}(1 - \frac{x}{a}, 0) & a \in \mathbb{R} \setminus [0] \end{cases}$$

### 6.5 The functional equation of multiplicative symmetry on an abelian group

In §2, we have investigated functional equations in a single variable with superposition of the unknown function. Related to these are the functional equations in two variables of a similar form which should normally be easier to study, and which are particular cases of the functional equation dealt with in Chapter VI, §2. Such are, for example, functional equations of the following kind

$$f(f(x)+y) + f(x+f(y)) = f(x) + f(y)$$

or

$$f(f(x)+y) + f(x+f(y)) = 2(f(x)+f(y)).$$

this last equation, with  $y = x$ , reduces to  $f(f(x)+x) = 2f(x)$ , which is Equation (7) of Chapter VI, §2. However, functional equations of this kind are considerably simplified if an assumption of symmetry is made, namely that  $f(f(x)+y) = f(x+f(y))$ . This provides us with a new, and rather typical functional equation on an algebraic structure  $(G, *)$ .

$$(1) \quad f(f(x)*y) = f(x*f(y))$$

The general solution of Equation (1) is known on an abelian group. The purpose of this section is to provide the reader with the proof and to obtain related results for functional equations of a similar form which appear in the next section and provide some applications to algebra.

Theorem 6.8 Let  $G$  be an abelian group.  $f: G \rightarrow G$  is a solution of the function equation

$$(1) \quad f(f(x)+y) = f(x+f(y)) \quad \text{for all } x, y \text{ in } G.$$



if and only if there exist two subgroups H and I of G, H included in I and two lifting h and i

$$h: G/I \rightarrow G/H \quad \text{and} \quad i: I/H \rightarrow I$$

such that

$$(2) \quad f(x) = i[\pi_H(x) - h(\pi_I(x))]$$

Proof  $\pi_I$  (respectively  $\pi_H$ ) is the canonical epimorphism from G onto G/I (or onto G/H). We have identified G/H/I/H with G/I as usual in group theory and  $\pi_H$  is then the canonical epimorphism from G/H onto G/I. We have by definition  $\pi_H \circ h \circ \pi_I = \pi_I$  and  $\pi_H \circ i \circ \pi_I(x) = \pi_H(x)$  for all x in I.

Let  $f: G \rightarrow G$  satisfy (2). We notice that

$$\pi_I(f(x)+y) = \pi_I(y) \quad \text{and} \quad \pi_I(x+f(y)) = \pi_I(x)$$

Therefore

$$\begin{aligned} f(x+f(y)) &= i[\pi_H(x+f(y)) - h(\pi_I(x))] \\ &= i[\pi_H(x) - h(\pi_I(x)) + \pi_H(y) - h(\pi_I(y))] \\ &= i[\pi_H(y+f(x)) - h(\pi_I(y))] \\ &= f(y+f(x)) \end{aligned}$$

Conversely, let  $f: G \rightarrow G$  be a solution of (1). Let us compute, for all x, y and z in G:

$$\begin{aligned} f(x+f(y+f(z))) &= f(x+f(f(y)+z)) \\ &= f(f(x)+f(y)+z) \\ &= f(y+f(f(x)+z)) \\ &= f(y+f(x+f(z))) \end{aligned}$$

Thus

$$(3) \quad f(x+f(y+f(z))) = f(x+f(y)+f(z))$$

Let H be the subgroup of G generated by all the elements of the form  $f(y+f(z)) - f(y) - f(z)$  where y, z are any elements in G. We define with the help of (3) a mapping of  $g: G/H \rightarrow G/H$  according to

$$g(\pi_H(x)) = \pi_H(f(x))$$

We can compute easily a functional equation for g:

$$g[\pi_H(x)+g(\pi_H(y))] = \pi_H[f(x+f(y))] = \pi_H(f(x)+f(y)) = g(\pi_H(x)) + g(\pi_H(y))$$

In other words, for all x, y in G/H.

$$(4) \quad g(x+g(y)) = g(x) + g(y)$$

The general solution of Equation (4) on an abelian group is not difficult to find. We leave this to the reader as we will later find the general solution of (4) on a quasi-group (cf proof of Theorem 6.10). There exists a subgroup H' of G/H such that

$$g(x) = x - h'(\pi_H(x)) \quad \text{for } x \text{ in } G/H$$

where  $\pi_{H'}$  is the canonical epimorphism from G/H onto G/H/H' and  $h': G/H/H' \rightarrow G/H$  a lifting relative to H'. There exists a subgroup I of G, I containing H, such that H' can be identified with I/H and we identify G/H/I/H with G/I. We denote by h the lifting  $h: G/I \rightarrow G/H$  relative to I/H. We have obtained

$$\pi_H(f(x)) = \pi_H(x) - h(\pi_I(x))$$



Finally, as  $\pi_H(x) - h(\pi_I(x)) \in I/H$ , with a lifting  $i: I/H \rightarrow I$  relative to  $H$

$$f(x) = i[\pi_H(x) - h(\pi_I(x))]$$

This ends the proof of Theorem 6.8. On a non abelian group, Theorem 6.8 has been generalized but with additional assumptions concerning  $f$ . It remains an open problem to find the general solution there as well as in the case of an abelian quasi-group (See bibliography). There is another way of stating Theorem 6.8.

Theorem 6.9 Let  $f: G \rightarrow G$  be a function on an abelian group  $G$ . This function satisfies

$$(1) \quad f(x+f(y)) = f(y+f(x)) \quad \text{for all } x, y \text{ in } G$$

if and only if  $f = f_2 \circ f_1$  where  $f_1$  and  $f_2$  are two functions such that

$$(5) \quad f_1: G \rightarrow G \text{ and } f_1(x+f_1(y)) = f_1(x) + f_1(y) \quad \text{for all } x, y \text{ in } G$$

and

$$(6) \quad f_2: I \rightarrow I \text{ and } f_2(x+f_2(y)) = f_2(x+y) \quad \text{for all } x, y \text{ in } I$$

where  $I$  is a subsemi-group of  $G$  and is the range of  $f_1$ .

Suppose  $f = f_2 \circ f_1$ , with the properties as stated in Theorem 6.9 for  $f_1$  and  $f_2$ . We get with  $z \in G$  such that  $f_1(z) = f_2 \circ f_1(y)$

$$\begin{aligned} f(x+f(y)) &= f_2 \circ f_1[x+f_1(z)] \\ &= f_2(f_1(x) + f_1(z)) = f_2(f_1(x) + f_2 \circ f_1(y)) \\ &= f_2(f_1(x) + f_1(y)) \end{aligned}$$

By symmetry

$$f(x+f(y)) = f(y+f(x))$$

Now let  $f$  satisfy (1) and define, using the notations of Theorem 6.8

$$f_1(x) = x - \tilde{h}(h(\pi_I(x))) \quad f_1: G \rightarrow G$$

where  $\tilde{h}: G/H \rightarrow G$  is any lifting relative to  $H$ . A simple computation shows that  $f_1$  satisfies Equation (5). Moreover  $f_1(x) \in I$  for all  $x$  in  $G$  and  $I$  is in fact the range of  $f_1$  (Take  $x \in I$ ; for example,  $f_1(x) = x - \tilde{h}(h(0))$ ). Define  $f_2: I \rightarrow I$ , using the lifting  $i$  introduced in Theorem 6.8, by

$$f_2(x) = i(\pi_H(x))$$

The function  $f_2$  satisfies Equation (6) as can be easily verified. Then we can compute  $f_2 \circ f_1(x)$ :

$$f_2 \circ f_1(x) = i[\pi_H(x) - \pi_H(\tilde{h}(h(\pi_I(x))))] = i[\pi_H - h(\pi_I(x))] = f(x)$$

Equation (5) and Equation (6) are particular cases of Equation (1) and it is now easy to find their solution on an abelian group. We postpone the results to the next section where results are given more generally on a quasi-group.

Corollary 6.4 Let  $f: \mathbb{R} \rightarrow \mathbb{R}$  be a non constant continuous function satisfying

$$(1) \quad f(x+f(y)) = f(f(x)+y) \quad \text{for all } x, y \text{ in } \mathbb{R}$$

There exists a real constant  $a$  and  $f(x) = x + a$  for all  $x$  in  $\mathbb{R}$

It has just to be noticed that the subgroup of periods of  $f$  is closed and contains  $H$  as defined in theorem 6.8. The following corollary can be proved with the same kind of computation.

Corollary 6.5 Let  $f: \mathbb{R} \rightarrow \mathbb{R}$  be a non constant continuous function. Then  $f$  satisfies the functional equation

$$(7) \quad f(xf(y)) = f(yf(x)) \quad \text{for all } x, y \text{ in } \mathbb{R}$$

if and only if  $f$  is of one of the following forms:

- (i)  $f(x) = ax$  for some  $a$  in  $\mathbb{R}$ ,  $a \neq 0$
- (ii)  $f(x) = \text{Sup}(bx, cx)$  for  $c \in \mathbb{R}$  with  $c \geq 0$ ,  $c > b$ ,  $b \leq 0$
- (iii)  $f(x) = \text{Inf}(dx, -dx)$  for  $d > 0$

Recall that we have already solved  $f(xf(x)) = (f(x))^2$  for a continuous  $f: [0, \infty[ \rightarrow [0, \infty[$  (Theorem 6.1).

In  $\mathbb{R}$ , an equation, apparently similar to (1), can be solved under a continuity assumption

$$(8) \quad f(x+f(y)) + f(x) = f(y+f(x)) + f(y)$$

We get solutions  $f(x) \equiv 0$ ;  $f(x) = 2(x-a)$  where  $a \in \mathbb{R}$  or

$f(x) = -\frac{1}{A} \text{Log}(1+e^{A(x-a)})$ ;  $A \neq a$ ,  $a \in \mathbb{R}$ ;  $A \in \mathbb{R} \setminus \{0\}$ , and the limits obtained from the last solution letting  $A$  tend to  $+\infty$  or to  $-\infty$ .

In  $\mathbb{R}^+$ ,  $f(xf(y))f(x) = f(yf(x))f(y)$  can be solved as well. But those equations have not been studied on more general algebraic structures.

## 6.6 Applications to algebra: associative and commutative mappings

$G$  being a set equipped with an associative binary operation  $*$ , we shall try to construct all other binary operations related to the first operation  $*$  in some specific way. Two explicit cases shall be investigated leading to similar computations.

Case 1 Find all associative binary operations  $\Delta$  on  $(G, *)$  such that for all  $x, y, z$  in  $G$  we have the following relation

$$(1) \quad (x * y) \Delta z = x * (y \Delta z)$$

Case 2 Let  $f: G \rightarrow G$  be a mapping and define a binary operation  $\perp$  over  $G$ , called the image of  $*$  through  $f$ , according to

$$(2) \quad x \perp y = f(x * y)$$

Find all mappings  $f: G \rightarrow G$  for which the image  $\perp$  is associative? We shall completely solve case 1 for an abelian quasi-group and case 2 for a monoid. Some definitions and notations may be useful here. A monoid  $(G, *)$  is a set  $G$  with an associative binary operation  $*$  on  $G$  which possesses a bilateral neutral element  $e$ . Such a monoid is called right regular if from the relation

$$x * z = y * z$$

we in fact may deduce  $x = y$ . A quasi group is a monoid which is right and left regular. An equivalence relation  $P$  on a monoid  $(G, *)$  is called compatible (with  $*$ ) if  $x_1 P y_1$  and  $x_2 P y_2$  imply that  $(x_1 * x_2) P (y_1 * y_2)$ . When such a compatible equivalence relation is given on a monoid  $(G, *)$ , we can consider the set  $G/P$  of all equivalence classes. This is a monoid too, when equipped with its canonical binary operation.

We still use  $*$  for this canonical operation. The canonical epimorphism from  $G$  onto  $G/P$  shall be denoted by  $\pi$ . A lifting for  $P$  is a mapping  $p: G/P \rightarrow G$  for which  $\pi \circ p \circ \pi = \pi$ . On a group  $(G, *)$ , a compatible equivalence relation  $P$  coincides with a normal subgroup  $H$  of  $G$  if we use  $x P y$  to say that  $x * y^{-1} \in H$  where  $H = \{x | x \in G \text{ and } x P e\}$ . This  $G/P$  is isomorphic to the quotient group  $G/H$  and  $\pi$  is the usual quotient mapping.

With any abelian quasi-group  $(G, *)$ , we associate a group  $(G^*, *)$  in the following classical way:

On the product  $G \times G$ , equipped with the product law, we define an equivalence relation  $R$  according to  $(x_1, y_1) R (x_2, y_2)$  if  $x_1 * y_2 = y_1 * x_2$ . Clearly  $R$  is compatible on  $G \times G$  and we define  $G^*$  to be  $(G \times G)/R$ . There exists a natural, homomorphic embedding of  $G$  into  $G^*$ , namely  $x \rightarrow \rho[(x, e)]$  where  $\rho$  denotes the canonical epimorphism from  $G \times G$  onto  $G/R$ . To make things simpler, we often shall write  $x$  instead of  $\rho[(x, e)]$ .

Case 1 This case is completely solved, for an abelian quasi-group  $(G, *)$ , with the following theorem.

Theorem 6.10 Let  $(G, *)$  be an abelian quasi-group. Let  $\Delta$  be a binary operation on  $G$  such that for all  $x, y$  and  $z$  in  $G$  we have  $(x * y) \Delta z = x * (y \Delta z)$ . Then  $\Delta$  is associative if and only if there exists a subgroup  $H$  of  $(G^*, *)$ , a lifting  $h$  for  $H$  such that for all  $x$  in  $G$  we have  $\{h[\pi(x)]\}^{-1} * x \in G$ , in such a way that for every  $x, y$  in  $G$

$$(3) \quad x \Delta y = x * \{h[\pi(y)]\}^{-1} * y$$

As a consequence, we shall prove:

Corollary 6.6 An associative operation  $\Delta$  satisfying (1) on an abelian quasi-group  $(G, *)$  may be extended to an associative operation  $\Delta^*$  satisfying the same equation (1) on the group  $(G^*, *)$ .

We divide the proof of Theorem 6.10 into several steps.

Lemma 6.4 Let  $(G, *)$  be a monoid and  $\Delta$  be a binary operation on  $G$ .  $\Delta$  satisfies Equation (1) if and only if there exists a mapping  $f: G \rightarrow G$  such that

$$(4) \quad x \Delta y = x * f(y)$$

Just use  $f(x) = e \Delta x$  with some easy computation. The second lemma is also easy to prove

Lemma 6.5 Let  $(G, *)$  be a monoid and  $f: G \rightarrow G$ . The binary operation  $\Delta$  defined by Equation (4) in Lemma 1 is associative if and only if  $f$  satisfies for all  $x, y$  in  $G$  the following functional equation

$$(5) \quad f(x * f(y)) = f(x) * f(y)$$

Our task then is to solve Equation (5) and for this we shall require  $*$  to be commutative from now on. Thus let  $(G, *)$  be an abelian quasi-group and let  $f: G \rightarrow G$  be a mapping satisfying Equation (3). We define a relation  $P$  on  $G$  according to  $t P t'$  when  $t' * f(x * t) = t * f(x * t')$  for all  $x$  in  $G$ .

Lemma 6.6  $P$  is a compatible, regular equivalence relation on  $(G, *)$

$P$  is obviously a reflexive, symmetric relation. For the

transitivity, we multiply the relation  $tPt''$  by  $t$  to get

$$\begin{aligned} t * t' * f(x * t'') &= t * t'' * f(x * t') = t'' * t * f(x * t') \\ &= t'' * t' * f(x * t) \end{aligned}$$

Since  $tP:t'$ .

Thus  $t' * t * f(x * t'') = t' * t'' * f(x * t)$  and with the help of the regularity of  $(G,*)$  we get  $tPt''$ .

Let us first show that  $tPt'$  if and only if  $t' * f(t) = t * f(t')$ .

With  $x = e$ , necessity is obvious. For the sufficiency, we use

$$f(x * t' * f(t)) = f(x * t') * f(t)$$

But

$$f(x * t' * f(t)) = f(x * t * f(t')) = f(x * t) * f(t')$$

Multiplying by  $t'$  and using the commutativity of  $*$

$$t' * f(x * t' * f(t)) = f(x * t') * t' * f(t) = f(x * t') * t * f(t')$$

and

$$t' * f(x * t' * f(t)) = t' * f(x * t * f(t')) = f(x * t) * t' * f(t')$$

By regularity, we deduce  $tPt'$ .

$P$  is a compatible relation on  $(G,*)$  as  $t_1Pt'_1$  and  $t_2Pt'_2$  imply that

$$(t_1 * t_2) * f(t'_1 * t'_2) = t'_1 * t_2 * f(t_1 * t_2) = (t'_1 * t'_2) * f(t_1 * t_2)$$

Moreover  $P$  is regular, which means that  $tPt'$  is equivalent to  $(t * y) P (t' * y)$ . One way is obvious as  $P$  is compatible. Suppose now that  $(t * y) P (t' * y)$ . Then

$$t' * y * f(x * t * y) = t * y * f(x * t' * y)$$

and so with  $z = x * y$

$$t' * f(z * t) = t * f(z * t')$$

Now, for any  $X$  in  $G$ , due to Equation (5)

$$\begin{aligned} t' * f(X * t' * f(z * t)) &= t' * f(X * t') * f(z * t) \\ &= t * f(X * t') * f(z * t') \end{aligned}$$

But

$$\begin{aligned} t' * f(X * t' * f(z * t)) &= t' * f(X * t * f(z * t')) \\ &= t' * f(X * t) * f(z * t') \end{aligned}$$

By cancellation of  $f(z * t')$ , we get back  $tPt'$ , which ends the proof of lemma 6.6.

Our next step is to extend  $P$  to the group  $(G^*,*)$ . First, let us define  $\tilde{P}$  on  $G \times G$  according to  $(x,y) \tilde{P} (x',y')$  if  $(x * y') P (y * x)$ . If we consider  $G$  as embedded into  $G \times G$  via  $x \rightarrow (x,e)$ , then  $\tilde{P}$  extends  $P$ . By computation it is shown that  $\tilde{P}$  is an equivalence relation on  $G \times G$ . Let us denote by  $R$  the equivalence relation for which  $G^* = (G \times G)/R$ . We undertake to show that if  $(x_1,y_1) \tilde{P} (x'_1,y'_1)$ ,  $(x'_1,y'_1) R (x'_2,y'_2)$  and  $(x_1,y_1) R (x_2,y_2)$  then  $(x_2,y_2) \tilde{P} (x'_2,y'_2)$ . Starting from  $(x_1 * y'_1) P (y_1 * x'_1)$ , we multiply by  $y_2$  and cancel  $y_1$  by the regularity of  $P$ . Thus  $(x_2 * y'_1) P (x'_1 * y_2)$ . By multiplication by  $x'_2$  and cancellation of  $x'_1$ , we get the required equivalence.

Thus  $\tilde{P}$  canonically defines an equivalence relation  $P^*$  on  $G^*$ . A routine computation shows the compatibility of  $P^*$  on  $(G^*,*)$ , which proves that  $P^*$  can be associated with a subgroup  $H$  of  $(G^*,*)$ .

Let  $t, t'$  be in  $G$  such that  $tPt'$ . We may write

$(t, f(t)) R (t', f(t'))$ . Thus  $\rho(t, f(t))$  is an element of  $G^*$  which depends only upon  $\pi(t)$ . We write  $\rho(t, f(t)) = h^*(\pi(t))$  where  $h^*: G/P \rightarrow G^*$ . But Equation (5) can be used in the following way

$$f(x * f(y)) * x = f(x) * x * f(y)$$

which proves  $(x * f(y)) P x$  for all  $x, y$  in  $G$ . As a consequence  $(f(y)) P e$  for every  $y$  in  $G$ .

Finally, let us write

$$f(x) = \rho(f(x), e) = \rho(f(x), x) * \rho(x, e)$$

and as  $\rho(f(x), x) = [\rho(x, f(x))]^{-1}$ , we get

$$f(x) = [h^*(\pi(x))]^{-1} * x.$$

This last expression must belong to  $G$  for all  $x$  in  $G$ . Moreover as  $\rho(f(x), e) P^* \rho(e, e)$ , we get

$$\begin{aligned} \pi(x) &= \pi^*(\rho(x, e)) = \pi^*(h(\pi(x))) * \pi^*(f(x)) \\ &= \pi^*(h^*(\pi(x))) \end{aligned}$$

which leads to  $\pi = \pi^* * h^* * \pi$ . Therefore, we may arbitrarily extend  $h^*$  to a lifting  $h$  for  $H$ ; i.e.  $G^*/H \rightarrow G^*$  and obtain for every  $x$  in  $G$

$$(6) \quad f(x) = [h(\pi(x))]^{-1} * x$$

Returning to the binary operation  $\Delta$ , we conclude

$$x \Delta y = x * [h(\pi(y))]^{-1} * y$$

Conversely, an  $f$  defined according to Equation (6), with the stated properties for  $\pi$  and  $h$ , satisfies Equation (5) as can be shown

by direct computation.

It should be noticed that the intersection  $I$  of  $G$  with the image of  $G^*/H$  through the lifting  $h$  coincides with the kernel of  $f$ . This kernel itself coincides with the set of all idempotents for  $(G, \Delta)$ . When  $G$  is a group, even a non-abelian one, a solution for Equation (5) can be based on this set  $I$ . However this set  $I$  can be empty in the case of a general quasi-group.

Example Let  $G$  be the abelian quasi-group of all positive integers with the additive operation. We get  $Z = G^*$  and with  $H = 3Z$ , a particular solution for  $f(n + f(m)) = f(n) + f(m)$  is

$$f(n) = n - ((n : 3)) + 3$$

where  $((n : 3))$  denotes the remainder of the division of  $n$  by 3.

Corollary 6.7 Let  $(G, *)$  be a simple abelian group. The only associative binary operations  $\Delta$  on  $G$  such that  $(x * y) \Delta z = x * (y \Delta z)$  are  $x \Delta y = x * y * a$  for some  $a$  in  $G$  or  $x \Delta y = x$ .

The proof of Corollary 6.6 is now easy. This corollary could also be stated in the following way.

For an abelian quasi-group  $G$  and an  $f: G \rightarrow G$  satisfying Equation (5), there exists an  $f^*: G^* \rightarrow G^*$  extending  $f$  and still satisfying Equation (5). Such an extension is not unique in general.

In the general case of a non-abelian group  $G$ , theorem 6.10 has to be slightly modified as  $H$  need not be normal but  $G^* = G$  and so  $G^*/H$  denotes the set of all left cosets.

In the case of an abelian group, it is however possible to

generalize Theorem 6.10.

Theorem 6.11 Let  $(G,+)$  be an abelian group and  $\Delta$  a binary operation in  $G$  such that  $e \Delta e = e$ . Suppose that  $[(x+y) \Delta z] - [y \Delta z]$  only depends on  $x$ . Then the operation  $\Delta$  is associative if and only if there exists a subgroup  $I$  of  $G$ , which is a factor of  $G$  such that  $G = G/I \oplus I$ , a subgroup  $H$  of  $I$ , a lifting  $h: I/H \rightarrow I$  with  $h(e) = e$  and a mapping  $i: G \rightarrow G/I$  for which  $i(e) = e$  and  $i(y+z) = z$  whenever  $y \in I$  and  $z$  belongs to the image of  $I$ , in such a way that

$$x \Delta y = \pi_I(x+y) - h(\pi_H(y)) + i(y)$$

Here  $\pi_H$  (respectively  $\pi_I$ ) denotes the quotient mapping onto  $G/H$  (respectively onto  $G/I$ ). A direct computation leads to the sufficiency of Theorem 6.10. For its necessity, let us write (cf. Lemma 6.4).

$$x \Delta y = g(x) + f(y)$$

where  $g: G \rightarrow G$  is some a priori unknown function. But  $g$  is necessarily an homomorphism. Indeed as  $\Delta$  is associative, we get

$$(7) \quad g(g(x) + f(y)) + f(z) = g(x) + f(g(y) + f(z))$$

From  $g(e) = e$  and  $e \Delta e = e$ , we deduce  $f(e) = e$ . With  $y = z = e$  in (7), we first get  $g(g(x)) = g(x)$ . Thus the image of  $g$  is a subgroup  $I$  and  $G/I$  is isomorphic to the kernel of  $g$ . We get  $G = I \oplus G/I$  via  $x = g(x) + (x - g(x))$ . Let us write  $\pi_I(x) = g(x)$  and  $\pi_{G/I}(x) = x - g(x)$ . With  $z = x = e$  in (7), we get

$$(8) \quad g(f(y)) = f(g(y))$$

Finally, with  $x = e$  in (7)

$$(9) \quad g(f(y)) + f(z) = f(g(y) + f(z))$$

Taking (8) into account, we deduce

$$f(g(y)) + f(z) = f(g(y) + f(z))$$

We clearly get  $f(I) \subset I$  and  $f(G/I) \subset G/I$ . Moreover with  $f' = g \circ f \circ g$

$$f'(y + f'(z)) = f'(y) + f'(z)$$

Theorem 6.10 provides the general solution of this equation. But  $f' = f \circ \pi_I$ . If we define  $i: G \rightarrow G/I$  according to

$$i(x) = \pi_{G/I} \circ f(x)$$

then since Equation (9) leads to

$$f(\pi_I(y) + \pi_I(f(z)) + \pi_{G/I}(f(z))) = f(\pi_I(y + f(z))) + f(\pi_{G/I}(f(z))),$$

we have that

$$i(\pi_I(y) + \pi_I(f(z)) + i(z)) = i(z)$$

This relation leads, for every  $y$  in  $I$  and every  $z$  in the range of  $i$ , to the relation

$$i(y + z) = z$$

Theorem 6.11 summarizes all these results.



Corollary 6.8 Let  $\Delta$  be an associative binary operation on the real axis. Suppose  $[(x + y) \Delta z] - (y \Delta z)$  only depend on  $x$ . Suppose too that  $x \Delta y$  is separately continuous in  $x$  and in  $y$ . Suppose that there exist  $x_0, y_0$  such that  $x \rightarrow x_0 \Delta x$  and  $x \rightarrow x \Delta y_0$  are not constant functions. Then there exists a constant  $a$  such that  $x \Delta y = x + y + a$ .

Continuity leads to  $g(x) = bx$  and idempotence to either  $b = 0$  which is impossible or to  $b = 1$ . As  $H$  must be closed we get either  $H = \mathbb{R}$  and so  $x \wedge y = x + y + a$  or  $H$  is discrete. However  $H = \{0\}$  is impossible and  $H = kz$  for some  $k > 0$  is impossible by continuity.

In the same vein, it is easy to deduce from Theorem 6.10 the following Corollary:

Corollary 6.9 Let  $(G, *)$  be an abelian topological group and  $f: G \rightarrow G$  be a continuous function. Then  $f$  satisfies Equation (5) if and only if  $f$  can be written as  $f(x) = (h(\pi(x)))^{-1} * x$  where  $\pi$  is the canonical epimorphism from  $G$  onto  $G/H$  for some closed subgroup  $H$  and  $h: G/H \rightarrow G$  is a continuous lifting.

Case 2 In order to introduce Case 2, we first consider an equation looking like Equation (1) but where we reverse the order of the two binary operations in the second member. Namely, let  $(G, *)$  be a monoid. Parallel to Lemma 6.1 is the following:

A binary operation  $\perp$  on  $G$  satisfies for all  $x, y, z$  in  $G$

$$(10) \quad (x * y) \perp z = x \perp (y * z)$$

if and only if  $\perp$  is the image of  $*$  under some  $f: G \rightarrow G$ . As in Theorem 6.10, we are looking for all such binary operations  $\perp$  which are associative.

Theorem 6.12 Let  $(G, *)$  be a monoid and  $\perp$  be a binary operation on  $G$  satisfying  $(x * y) \perp z = x \perp (y * z)$  and such that  $e \perp e = e$ . Then  $\perp$  is associative if and only if there exists a compatible equivalence relation  $P$  on  $(G, *)$ , and a lifting  $h$  for  $P$  with  $h(e) = e$ , in such a way that for all  $x$  in  $G$

$$x \perp y = h(\pi(x * y))$$

Corollary 6.10 Let  $(G, *)$  be a monoid and  $f: G \rightarrow G$  a non-periodic function fixing  $e$ . The image of  $*$  under  $f$  is associative if and only if  $f$  is the identity.

Sufficiency in the proof of Theorem 6.12 comes from the following computation

$$\begin{aligned} (x \perp y) \perp z &= h(\pi((x \perp y) * z)) = h(\pi(x \perp y) * \pi(z)) \\ &= h(\pi(x) * \pi(y) * \pi(z)) \\ &= h(\pi(x * y * z)) \\ &= h(\pi(x) * \pi(y \perp z)) \\ &= h(\pi(x * (y \perp z))) \\ &= x \perp (y \perp z) \end{aligned}$$

Necessity can be proved as follows. First we notice that  $x \perp y = f(x * y)$  for some  $f: G \rightarrow G$ . Therefore associativity for  $\perp$  implies

$$(11) \quad f(f(x * y) * z) = f(x * f(y * z))$$

with  $y = e$  in (11), we get

$$(12) \quad f(f(x) * z) = f(x * f(z))$$

with  $z = e$  in (11), we get



$$f(f(x * y)) = f(x * f(y))$$

But  $z = e$  in (12) leads to  $f(f(x)) = f(x * f(e))$  so that

$$f(x * y * f(e)) = f(x * f(y)) = f(f(x) * y)$$

In theorem 6.12, we supposed  $e \perp e = e$  so that  $f(e) = e$ .

(However, we could avoid such a hypothesis, replacing it with  $e \perp e = \lambda$  where  $\lambda$  is an invertible element in the center of  $(G, *)$ . In such a situation, the theorem will remain valid but with  $P$  non compatible in general). Here we get

$$(13) \quad f(x * y) = f(x * f(y)) = f(f(x) * y)$$

We may define a relation  $P$  over  $G$  according to  $tPt'$  if  $f(x * t * y) = f(x * t' * y)$  for every  $x, y$  in  $G$ . Obviously  $P$  is an equivalence relation. In fact  $tPt'$  if and only if  $f(t) = f(t')$ . With  $x = y = e$ , one way is obvious. The converse comes from a combinatorial identity deduced from Equation (13):

$$f(x * y * t) = f(f(x * y) * t) = f(f(x * f(y)) * t) = f(x * f(y) * t)$$

or

$$(14) \quad f(x * y * t) = f(x * f(y) * t) \quad \text{for all } x, y, t \in G.$$

Therefore if  $f(t) = f(t')$  we compute  $tPt'$  as

$$f(x * t * y) = f(x * f(t) * y) = f(x * f(t') * y) = f(x * t' * y).$$

Let now  $t_1Pt'_1$  and  $t_2Pt'_2$  and use Equation (13) many times.

$$\begin{aligned} f(t_1 * t_2) &= f(t_1 * f(t_2)) = f(f(t_1) * f(t_2)) = f(f(t'_1) * f(t'_2)) \\ &= f(t'_1 * f(t'_2)) = f(t'_1 * t'_2) \\ &= f(t'_1 * t'_2) \end{aligned}$$

which gives  $(t_1 * t_2) P (t'_1 * t'_2)$  and so ends the proof that  $P$  is a compatible relation.

We have seen that  $f(t)$  only depends on the equivalence class of  $t$ , which implies the existence of an  $h: G/P \rightarrow G$  such that

$$f(t) = h(\pi(t))$$

However Equation (14) states that  $tP(f(t))$  for all  $t \in G$ . Thus  $\pi \circ f(t) = \pi(t)$  or  $\pi \circ h \circ \pi = \pi$  and so  $h$  is a lifting for  $P$ . Such a lifting satisfies  $h(e) = e$  as  $f(e) = e$ , which completes the proof of Theorem 6.12.

An analog to Corollary 6.6 with Equation (10) is not possible. In fact, we shall give an example of an associative binary operation  $\perp$  satisfying Equation (10) on an abelian quasi-group  $(G, *)$  but which cannot be extended to an associative operation  $\perp^*$  on  $(G^*, *)$  still satisfying Equation (10). The reason is that the relation  $P$  is not regular in general.

Example Let  $(N, +)$  be the set of all natural numbers  $n \geq 0$  equipped with the additive operation. The binary operations  $\perp$  on  $(N, +)$  satisfying

$$(x + y) \perp z = x \perp (y + z)$$

are precisely the following.

- (a)  $x \perp y = x + n_0$  for some  $n_0 \in \mathbb{N}$   
 (b)  $x \perp y = x + y$  for  $0 \leq x + y < n_1$   
        $= g(x + y)$  for  $n_1 \leq x + y$

where  $n_1$  is a fixed strictly positive integer and  $g: [n_1, \infty[ \cap \mathbb{N} \rightarrow \mathbb{N}$  a periodic function of period  $n_2$  (where  $n_2$  is a fixed strictly positive integer) such that

$$g(t) = t + k(t)n_2$$

for  $t \in \{n_1, n_1+1, \dots, n_1+n_2-1\}$  where  $k(t) \in \mathbb{N}$

(c)  $x \perp y = g(x + y) - n_0$  where  $g: \mathbb{N} \rightarrow \mathbb{N}$  is a periodic function of period  $n_2$ , a strictly positive integer, such that  $n_0 \in n_2\mathbb{N}$  and

$$g(t) = t + k(t)n_2$$

for  $t \in \{0, 1, \dots, n-1\}$  with  $k(t) \in \mathbb{N}$ , along with the restriction that  $k(0) = 2n_0$  and  $g(t) \geq n_0$ .

This result comes from Theorem 6.12 (plus a certain computation as we do not impose  $0 \perp 0 = 0$ ) and from the determination of all compatible equivalence relations on  $(\mathbb{N}, +)$ . We omit the proof. Case (b) is a convenient example of an operation  $\perp$ , not extendable to the set  $\mathbb{Z}$  of all integers.

With the help of Theorem 6.8, a last case is not difficult to obtain.

Corollary 6.11 Let  $G$  be an abelian group and  $f: G \rightarrow G$  such that  $f(e) = e$ . We set  $x \square y = f(x + f(y))$ . The binary operation  $\square$  is associative if and only if  $\square$  is commutative, i.e. there exists two subgroups  $H$  and  $I$  of  $G$ ,  $H \subset I$ , two liftings  $h: G/I \rightarrow G/I$  and

$i: I/H \rightarrow I$  such that  $h(e) = e$ ,  $i(e) = e$  and

$$x \square y = i[\pi_H(x+y) - h(\pi_I(x)) - h\pi_I(y)]$$

The fact that  $\square$  is associative if and only if  $\square$  is commutative can be proved more generally for an abelian monoid  $(G, +)$ . However the functional equation of commutativity has not as yet been solved on a quasi-group. The difficulty seems to come from the fact that the equivalence relation introduced for Case 2 is not regular in general.

## CHAPTER 7

## Operator theory and functional equations

*Programme* We intend to provide examples of the use of functional equations in operator theory. We shall begin by studying Reynolds operators, a rather large class of linear operators, which plays some part in turbulence theory in hydrodynamics and in probability theory. They are defined by a functional equation. Then we shall proceed to  $D(\alpha)$ -operators and to linear derivation. Afterwards we shall study the so-called multiplicatively symmetric operators. We shall conclude with a functional equation which occurred in the study of extreme operators.

Functional equations appear quite often in operator theory. After all, a linear operator  $P$ , from a vector space  $E$  into a vector space  $F$  over some scalar field, satisfies the two functional equations:

$$\begin{cases} P(f+g) = P(f) + P(g) & \text{for all } f, g \text{ in } E \\ P(\lambda f) = \lambda P(f) & \text{for all } f \text{ in } E \text{ and } \lambda \text{ in the} \end{cases}$$

scalar field of both  $E$  and  $F$ .

Another striking example is the study of semi-groups of operators

$$P_{t+u} = P_t \circ P_u$$

A derivation operator, i.e. a linear operator satisfying the functional equation:

$$P(fg) = Pf \cdot g + f \cdot Pg,$$

plays an important part in the analysis of Banach algebras. In order to keep these notes introductory, we shall content ourselves with few examples of an elementary level.

### 7.1 Reynolds operators

In order to give a theoretical definition for a turbulent fluid motion, it is generally said that the velocity of a particle or the pressure at a given point in such a fluid presents "irregular" fluctuations around an average value, both for the time variable and for the space variable. It appears that averages, and averages which are not constant functions, are here essential. Obviously, random functions are well suited to the search for such averages and a great number of investigations concerning turbulent fluid motions use probability theory, and therefore mathematical expectations as averaging operators. This means that averages are computed via many different experiments done at random. Another point of view, historically the first, was to study averages along a time variable by using an expression such as  $\frac{1}{2T} \int_{-T}^{+T} f(t) dt$  (and its limit when  $T$  increases) or to study averages along a space variable by using similar integrals. Naturally, the link between these two investigations is to be found in ergodic theorems. However, following this latter averaging approach, we may look for the axiomatic rules to be satisfied by what shall be considered as an average for a function. Because much freedom remains, we may require the linearity of the correspondence between  $f$  and its average  $Pf$ . We also may ask for

some assumption of continuity on the linear operator  $P$  (or more restrictively a positivity assumption). There is a need for a supplementary property since linearity and continuity are far too general to provide a means of obtaining useful averaging methods. An idea, originated by O. Reynolds, is to look for an operator  $P$  "commuting" with the differential operator governing fluid motion, namely the Navier-Stokes equation. Recall that the vectorial Navier-Stokes equation, valid for a newtonian fluid, can be written as

$$(1) \quad \rho \frac{\partial \vec{V}}{\partial t} = \rho \vec{f} - \text{grad } p + \nu \rho \Delta(\vec{V}) - \rho \text{div}(\vec{V} \otimes \vec{V})$$

where  $\vec{V}(t, M)$  is the velocity at a point  $M$  and at time  $t$ , the components of which are  $V_1, V_2$  and  $V_3$ . In Eq (1),  $\Delta \vec{V}(t, M)$  is a vector whose components are  $\Delta V_1, \Delta V_2$  and  $\Delta V_3$ ,  $p$  is the pressure,  $\vec{f}$  an external force and  $\text{div}(\vec{V} \otimes \vec{V})$  is a non linear term, which denotes a vector whose components are equal to  $\sum_{j=1}^3 \frac{\partial}{\partial x_j} (V_i V_j)$  for  $i = 1, 2$  and  $3$ .

Eventually, for incompressible fluids, we must add

$$(2) \quad \text{div } \vec{V} = 0$$

O. Reynolds looked for an operator  $P$  acting on  $\vec{V}$  and  $p$  in such a way that  $P(\vec{V})$  satisfies a Navier-Stokes equation with a supplementary term, the turbulent one, considered as added to the external force

$$(3) \quad \rho \frac{\partial P(\vec{V})}{\partial t} = P[\vec{f} - \text{div}((\vec{V} - P(\vec{V})) \otimes (\vec{V} - P(\vec{V})))] + \nu \rho \Delta P(\vec{V}) - \rho \text{div}(P(\vec{V}) \otimes P(\vec{V})) - \text{grad}(P(p))$$

It has been proved that if  $P$  acts on the variable  $t$  only, then (3) is

a consequence of (1) if we add to some continuity and stationary assumptions on  $P$  (which means commutation with translations) the equation:

$$P(f^2) = (Pf)^2 + P(f-Pf)^2$$

This leads to the functional equation characterizing Reynolds operators which is

$$(4) \quad P(fPg + Pf) = PfPg + P(PfPg)$$

Reynolds operators have been studied by many authors (see bibliographical references).

#### 7.1.1 Reynolds Operators Over Periodic Functions

Let  $k$  be any positive integer. We denote by  $C(T_k)$  the algebra of all continuous  $2\pi/k$ -periodic functions defined over  $\mathbb{R}$  and taking on complex values. For  $k = 0$ ,  $C(T_0)$  is simply the set of all constant functions. We endow  $C(T_k)$  with the uniform norm. For every real number  $h$ , the operator  $T_h$  represents the translation operator:

$$T_h f: x \rightarrow f(x+h)$$

A linear operator  $P: C(T_k) \rightarrow C(T_k)$  is stationary when, for every real number  $h$ , we have the commutative property

$$(5) \quad P(T_h(f)) = T_h(P(f))$$

To get acquainted with Reynolds operators, our first task shall be to describe all continuous and stationary Reynolds operators over  $C(T_1)$ .

Let us begin with some definitions.

Let  $k$  be any positive integer

$$(a) \quad \text{For } k = 0, \text{ we define } P_0 f = \frac{1}{2\pi} \int_{-\pi}^{+\pi} f(t) dt$$

$$(b) \quad \text{For } k \neq 0, \text{ we define } P_k f(x) = \frac{f(x) + f(x+\frac{2\pi}{k}) + \dots + f(x+\frac{k-1}{k}2\pi)}{k}$$

The operator  $P_k$  is defined over  $C(T_1)$  and takes its values in  $C(T_k)$ .

Now let  $s$  be any complex number (finite or not) such that  $s$  is different from a multiple of  $k$ . We define the operator  $R_s$ , from  $C(T_k)$  into  $C(T_1)$ , by the following equation:

$$(c) \quad R_s f(x) = \frac{s}{2\sin\frac{\pi s}{k}} \int_{-\frac{\pi}{k}}^{+\frac{\pi}{k}} e^{-its} f(x-t\frac{\pi}{k}) dt$$

and for the case where  $s$  is equal to  $\infty$ :

$$(d) \quad R_\infty f(x) = f(x) \quad R_\infty \text{ is the identity operator.}$$

Theorem 7.1 A non-zero, stationary and continuous linear operator over  $C(T_1)$  is a Reynolds operator if and only if there exist an integer  $k$  and a complex number  $s$ , different from a multiple of  $k$ , such that

$$P = R_s \circ P_k$$

Proof. Consider the functions  $e_n$  defined by  $e_n: x \rightarrow e^{inx}$  where  $n$  is any relative integer. These functions are the only eigen-functions for all operators  $T_h$  and, due to the commutation property (5) for  $P$  and  $T_h$ , are also eigen-functions of  $P$ , which gives:

$$(6) \quad P(e_n) = a(n)e_n,$$

where  $a_n \in \mathbb{C}$ .

Computing Reynolds relation with  $f = e_n$  and  $g = e_m$

$$(7) \quad P(e_n P(e_m)) + P(e_m P(e_n)) = P(e_n)P(e_m) + P(P(e_n)P(e_m))$$

which implies a relation for the function  $n \rightarrow a(n)$  defined over  $\mathbb{Z}$ :

$$(8) \quad a(n+m)(a(n)+a(m)) = a(n)a(m)+a(n)a(m)a(n+m)$$

Now define a subset  $\Lambda$  of  $\mathbb{Z}$  by  $\Lambda = \{n \mid n \in \mathbb{Z} : a(n) \neq 0\}$ .

0 belongs to  $\Lambda$ , because  $2a^2(0) = a^2(0) + a^3(0)$  yields  $a(0) = 0$  or  $a(0) = 1$ . But  $a(0) = 0$  implies  $a(n) = 0$  for all  $n$  and so  $P \equiv 0$  which is excluded. Therefore  $a(0) = 1$ .

Suppose  $n$  is in  $\Lambda$ , then  $a(n) + a(-n) = 2a(n)a(-n)$  which proves that  $a(-n)$  is different from 0 and so  $-n$  is too in  $\Lambda$ .

Finally, we have proved that  $\Lambda$  is a subgroup of  $\mathbb{Z}$ . Therefore, there exists an integer  $k$  such that  $\Lambda = k\mathbb{Z}$ .

Relation (8), for  $n$  and  $m$  restricted to  $\Lambda$ , provides

$$\frac{1}{a(n)} + \frac{1}{a(m)} = \frac{1}{a(n+m)} + 1$$

Defining  $b(n) = \frac{1}{a(n)} - 1$ , which is possible for  $n$  in  $\Lambda$ , we get the familiar functional equation of Cauchy:  $b: \mathbb{Z} \rightarrow \mathbb{C}$ .

$$(9) \quad b(n+m) = b(n) + b(m)$$

As  $n$  and  $m$  are multiples of  $k$ , we then get

$$b(n) = \frac{n}{k} b(k)$$

where  $b(k)$  is a complex number such that  $b(n) + 1$  is different from zero. This implies  $b(k) \neq -\frac{k}{n}$  for all  $n$  which are non-zero multiples of  $k$ .

(a) The case  $b(k) = 0$  implies  $a(n) \equiv 1$  for  $n$  in  $\Lambda$ .

According to the continuity of the operator  $P$ , and a theorem like Fejér's theorem, if  $f$  is expanded into its Fourier series along

$$f \sim \sum_n c_n e^{inx} \quad \text{where} \quad c_n(f) = \frac{1}{2\pi} \int_{-\pi}^{+\pi} f(t) e^{-int} dt$$

then  $Pf$ , in turn, possesses the following Fourier expansion

$$Pf \sim \sum_n c_{nk} e^{inkx}$$

If  $k = 0$ , we get directly  $Pf = c_0(f)$ , that is  $Pf = P_0 f = \frac{1}{2\pi} \int_{-\pi}^{+\pi} f(t) dt$ .

according to the notation defined just before theorem 7.1.

If  $k$  is different from 0, we see after some easy computation, using the unicity of the Fourier expansion of functions in  $c(T_1)$  that  $P = P_k$  where

$$(10) \quad P_k(f)(x) = \frac{f(x+\frac{2\pi}{k}) + \dots + f(x+\frac{k-1}{k} 2\pi)}{k}$$

We note that  $P_1(f) = f$ , that is  $P_1$  is the identity operator.

(b) The second case is for  $b(k) \neq 0$  and we suppose first that  $k = 1$ . We can then define  $b(1) = \frac{1}{s}$  where  $s$  is a complex number but not an integer. Then the Fourier expansion of  $Pf$  is given by

$$(11) \quad Pf \sim \sum_n c_n \frac{1}{n(n \cdot \frac{1}{s} + 1)} e^{inx}$$

because  $a(n) = (n \cdot \frac{1}{s} + 1)^{-1}$  for  $n$  in  $\Lambda = \mathbb{Z}$  due to equation (9).



Then, taking derivatives in the sense of distribution\*, we get the following differential equation concerning  $Pf$ :

$$(12) \quad \frac{1}{is} \frac{d(Pf)}{dx}(x) + Pf(x) = f(x)$$

Using the fact that  $Pf$  must belong to the algebra  $C(T_1)$  we find, after some computation, a solution for (12):

$$Pf(x) = R_s f(x) = \frac{is}{1-e^{-2\pi s}} \int_0^{2\pi} e^{-ist} f(x-t) dt = \frac{s}{2s \sin \pi s} \int_{-\pi}^{+\pi} e^{-its} f(x-t-\pi) dt$$

(c) When  $k \neq 1$ , then we first use  $P_k$  from  $C(T_1)$  into  $C(T_k)$  and then compose it with  $R_s$  from  $C(T_k)$  into  $C(T_k) \subset C(T_1)$  in order to obtain the operator  $P$ , the image of which is included in  $C(T_k)$

$$P = R_s \circ P_k$$

This comes from the fact that we have obtained the following Fourier series for  $Pf$ :

$$(13) \quad Pf \sim \sum_n c_n \frac{1}{nk} \frac{1}{s} e^{inkx}$$

because we have taken  $b(k) = \frac{k}{s}$  and so  $s$  must not be a multiple of  $k$ .

\* In the sense of distribution, which theory we do not intend to cover here, the "derivative" of  $f \in C(T_1)$ , where  $f(x) \sim \sum_n c_n e^{inx}$  is  $\frac{df}{dx}(x) \sim \sum_n inc_n e^{inx}$ . Then for a differentiable  $f$ , the derivative of  $f$  in the distribution sense coincides with its usual derivative. This explains why we solve the differential equation (12) in the ordinary way.

Conversely, it is possible to verify that any operator like  $P_k = R_\infty \circ P_k$  or  $R_s \circ P_k$  is a continuous Reynolds operator which commutes with translation operators on the algebra  $C(T_1)$ .

Corollary 7.1. *An idempotent, non-zero, stationary and continuous Reynolds operator on  $C(T_1)$  is of the form  $P_k$  as given by theorem 7.1.*

Operators like  $P_k$  appear as typical averaging operators. It is possible to prove directly that  $P_k$  satisfies the following equation

$$(14) \quad P_k(fP_k(g)) = P_k(f)P_k(g)$$

which is the functional equation characterizing *semi-multiplicative symmetric operators* sometimes called averaging operators. Equation (14) tells us that  $P_k(g)$  behaves as a constant for the operator.

Conversely, all non-zero stationary and continuous operators on  $C(T_1)$  satisfying equation (14) are of the form  $P_k$ . More generally, following the same lines, we can prove

Proposition 7.1. A bounded linear operator  $P$  on  $C(T_1)$  such that  $P(1) = 1$  and which is multiplicatively symmetric, that is which satisfies  $P(fPg) = P(gPf)$  for all  $f$  and  $g$  in  $C(T_1)$ , is stationary if and only if it is of the form  $P_k$  of theorem 7.1.

Obviously, with averaging properties,  $P_k$  also manifests smoothing properties. For example, if  $f$  is of bounded variation, then  $V(P_k f) \leq V(f)$ , where  $V$  denotes the total variation of  $f$ .

In the same way,  $R_s$  also has a smoothing property in the sense that  $R_s f$  is more regular than  $f$  because its  $n$ -th Fourier coefficient is more quickly converging towards zero when  $n$  tends to infinity. For example,  $R_s(f)$ , for  $f$  in  $C(T_1)$ , always possesses an absolutely convergent Fourier series as can be seen by the following inequality

$$(15) \quad \sum \left| \frac{c_n(f)}{s^{n+1}} \right| \leq \left( \sum_n |c_n(f)| \right)^{1/2} \left( \sum_n \frac{1}{|s^{n+1}|^2} \right)^{1/2}$$

We have seen that operators  $P_k$  possess both averaging and smoothness properties. However,  $R_s$  has only a smoothing property, according to the following easy corollary:

Corollary 7.2 A continuous and stationary Reynolds operator  $P$  over  $C(T_1)$  is one-to-one if and only if  $P$  is an operator of type  $R_s$ .

Let us now give a quantitative measurement of the smoothness of  $R_s$  as an operator from  $C(T_1)$  into  $C(T_1)$ .

If  $f$  has Fourier coefficients such that  $\sum_n |c_n(f)|$  is a convergent series, then we have

$$V(R_s f) \leq \frac{2\pi}{\varepsilon} \sum_n |c_n(f)|$$

where  $V(R_s f)$  denotes the total variation of  $R_s f$  and  $\varepsilon$  is defined by

$$\inf_{n \in \mathbb{Z}} \left| \frac{1}{n+s} \right| = \frac{1}{\varepsilon}.$$

If  $f$  itself is of bounded variation, then

$$V(R_s f) \leq A(s)V(f)$$

and  $A(s)$  is a constant depending only upon  $s$ . Obviously  $A(s) = \|R_s\|$  which is the norm of the bounded operator  $R_s$  for the uniform norm (Note, by contrast that  $\|P_k\| = 1$ ).

The operator  $R_s$  transforms real functions into real functions if and only if  $s$  is a purely imaginary number, let us say  $s = is'$ . In

this last case  $\|R_s\| = 1$  and moreover  $R_s$  is a positive operator. As a side result, we note that if  $P$  is a linear Reynolds operator satisfying the hypothesis of theorem 7.1, and transforms real functions into real functions, then  $P$  is a positive operator because both  $R_s$  and  $P_k$  are positive operators under these conditions.

Writing  $s = s_1 + is_2$ , we find from a simple computation

$$(16) \quad \text{when } s_2 \neq 0, \text{ then } \|R_s\| = \left\{ \frac{\left(\frac{s_1}{s_2}\right)^2 + 1}{\frac{\sin^2 \pi s_1}{\text{sh}^2 \pi s_2} + 1} \right\}^{1/2} \geq 1$$

and so we can find an operator  $R_s$ , the norm of which is as near to 1 as we wish,

$$(17) \quad \text{when } s_2 = 0, \text{ then } \|R_s\| = \left| \frac{\pi s_1}{\sin \pi s_1} \right| > 1 \text{ for } s_1 \neq 0.$$

Naturally, if  $P$  and  $P'$  are operators satisfying the hypothesis of theorem 7.1, then  $P \circ P' = P' \circ P$ . However the commutative product  $R_s \circ R_t = R_t \circ R_s$  is not a Reynolds operator in opposition with  $P_k \circ P_l = P_m$ , where  $m$  is the least common multiple of  $k$  and  $l$ .

Obviously, theorem 7.1 remains true if we replace the continuity of the operator  $P$  for the uniform norm by the continuity of  $P$  for an LP-norm, with  $p \geq 1$ , or any functional norm for which  $f \rightarrow c_n(f)$  are continuous linear forms.

### 7.1.2 Reynolds Operators over $C_R(X)$

A Reynolds operator  $P: A \rightarrow A$  on an algebra  $A$ , is a linear operator such that

$$(4) \quad P(fPg + gPf) = Pf \cdot Pg + P(Pf \cdot Pg) \text{ for all } f, g \text{ in } A.$$

It is then clear that  $P(A)$ , the image of the algebra  $A$  under  $P$ , is also a subalgebra.

An averaging operator  $P: A \rightarrow A$ , on algebra  $A$ , is a linear operator such that for all  $f, g$  in  $A$ :

$$(18) \quad P(f \cdot Pg) = Pf \cdot Pg$$

There are close relations between Reynolds operators and averaging operators. A quite general result is the following.

Theorem 7.2 Let  $P$  be a continuous Reynolds operator over  $C_R(X)$ , the Banach algebra of all real valued continuous functions on a compact space  $X$ . Suppose  $X$  is a totally disconnected compact Hausdorff space. Then  $P$  is an idempotent averaging operator.

Lemma 7.1 Let  $P$  be a Reynolds operator over an algebra  $A$ . For all  $n \geq 1$ , the following formula holds

$$nP(f(Pf)^{n-1}) = (Pf)^n + (n-1)P(Pf)^n.$$

For  $n = 1$ , this equality is trivial. For  $n = 2$ , it follows from the definition of a Reynolds operator. We now proceed by induction. We suppose the formula true for  $n$ . Then,

$$P(f(Pf)^n) = nP(f \cdot P(f(Pf)^{n-1})) - (n-1)P(f \cdot P(Pf)^n)$$

Using the Reynolds identity twice in the second member, we get

$$(n+1)P(f(Pf)^n) = n[Pf \cdot P(f(Pf)^{n-1}) + P(Pf \cdot P(f(Pf)^{n-1}))] - (n-1)[Pf \cdot P(Pf)^n + P(Pf \cdot P(Pf)^n) - P(Pf)^{n-1}]$$

Replacing twice  $nP(f(Pf)^{n-1})$  by the value given in the induction formula, we get

$$(n+1)P(f(Pf)^n) = [(Pf)^{n+1} + (n-1)P(Pf)^n \cdot Pf + P(Pf)^{n+1} + (n-1)P(Pf)^n \cdot Pf] - (n-1)P(Pf)^n \cdot Pf + (n-1)P(Pf)^{n+1} - (n-1)P((Pf)^n \cdot Pf)$$

and so

$$(n+1)P(f(Pf)^n) = (Pf)^{n+1} + nP(Pf)^{n+1}$$

which ends the proof.

Lemma 7.2 Let  $X$  be a compact Hausdorff space. The space  $C_R(X)$  is the closed linear hull of its idempotents if and only if  $X$  is totally disconnected.

An element of  $C_R(X)$  is an idempotent if and only if it is the characteristic function of a clopen set (both open and closed) and so always belongs to the unit ball of  $C_R(X)$ . Let us first recall what a totally disconnected space is.

A topological space  $X$  is totally disconnected if the largest connected subset containing a point  $x$  of  $X$  is reduced to  $\{x\}$ .

For compact spaces, a classical result asserts that the largest connected subset containing a point  $x$ , call it  $C(x)$ , is the intersection of all clopen sets of  $X$  containing  $x$ . Suppose that  $C(x)$  is the closed linear hull of its idempotents and suppose  $C(x)$  contains a point  $y \neq x$ . There exists an  $f \in C_R(X)$  with  $f(x) \neq f(y)$ . But for any  $\varepsilon > 0$ , there exists  $f_\varepsilon$  in the linear hull of the idempotents of  $C_R(X)$  such that

$$\|f - f_\epsilon\| \leq \epsilon$$

However  $f_\epsilon(x) = \sum_{i=1}^m a_i \chi_i(x) = \sum_{i=1}^m a_i \chi_i(y) = f_\epsilon(y)$  as  $\chi_i$  is the

characteristic function of a clopen subset of  $X$  and so equal to zero or one simultaneously for  $x$  and  $y$ . Then  $|f(x) - f(y)| \leq 2\epsilon$  which is contradictory and proves that  $X$  is totally disconnected. Conversely, suppose that  $X$  is totally disconnected. It is easy to see that the linear hull  $H$  of the idempotents of  $C_R(X)$  is a subalgebra of  $C_R(X)$ , containing constant functions. Moreover  $H$  separates  $X$  when  $X$  is totally disconnected. The Stone-Weierstrass theorem says precisely that  $H$  is dense in  $C_R(X)$ .

Theorem 7.2 is now easy. Let  $Pf$  be an idempotent in the image  $P(C_R(X))$ .

We get using lemma 7.1

$$P(f \cdot Pf) = \frac{1}{n} Pf + (1 - \frac{1}{n})P(Pf)$$

Letting  $n$  grow to infinity,

$$P(Pf) = P(f \cdot Pf) \text{ and so } P(Pf) = Pf$$

We therefore get  $P$  as the identity operator over the idempotents in the image of  $C_R(X)$  under  $P$ . But the closure of this image can be proved to be isomorphic to some  $C_R(Y)$  for a totally disconnected and compact  $Y$ , due to the same Stone-Weierstrass theorem.

In fact, let  $B$  be the closure of  $P(C_R(X))$ . Due to the Reynolds property,  $B$  is a closed subalgebra of  $C_R(X)$ . Let us introduce an equivalence relation  $P$  on  $X$

$xPy$  if and only if  $Pf(x) = Pf(y)$  for all  $f$

The topological quotient space  $X/P$  is a compact Hausdorff space. The Stone-Weierstrass theorem then asserts that  $B$  is isomorphic to  $C_R(X/P)$ . But  $X/P$  is totally disconnected too. Using what we proved for idempotents in the image of  $P$ , and the fact that  $P^2 = P$ , we deduce that  $P$  is the identity operator on its image, i.e.  $P(Pf) = Pf$ . Turning back to Reynolds identity, we get replacing  $f$  by  $Pf$ :

$$P(Pf \cdot Pg) + P(g \cdot Pf) = Pf \cdot Pg + P(Pf \cdot Pg)$$

and so the characteristic equation of an averaging operator:

$$P(f \cdot Pg) = P(g \cdot Pf) = Pf \cdot Pg$$

Corollary 7.3 A Reynolds operator on  $C_R(X)$ , where  $X$  is a finite subset, is an idempotent averaging operator.

Theorem 7.2 remains true, with a similar proof, if  $P$  is acting on a real Banach algebra  $A$  such that the range of  $P$  is isomorphic to some  $C_R(X)$ , where  $X$  is a totally disconnected and compact space. Such a generalization can be applied to the case where  $A$  is the Lebesgue space  $L^\infty(\Omega, F, \mu)$  of all essentially bounded real valued functions on a measure space  $(\Omega, F, \mu)$ . This may lead to a generalization to the Lebesgue spaces  $L^p(\Omega, F, \mu)$ , for  $1 < p < \infty$  and up to  $p = 1$ . (The required property there is for the range of  $P$  to be closed). We shall proceed in 7.3 to study averaging operators on algebras such as  $C(X)$ . We shall even study more general linear operators, the so-called multiplicatively symmetric operators. However, before doing so, we shall link Reynolds operators with the so-called  $D(\alpha)$ -operators and with derivation operators.

7.2  $D(\alpha)$ -operators

For both algebraical and combinatorial reasons, it is interesting to introduce operators satisfying functional equations similar to that of the Reynolds operators.

A subclass of such operators is that of the so-called  $D(\alpha)$ -operators.

Definition 7.1 A linear  $D(\alpha)$ -operator  $P: A \rightarrow A$  on an algebra  $A$  is such that for all  $f, g$  in  $A$

$$(1) \quad P(f \cdot Pg + gPf) = \alpha P(fg) + (1-\alpha)Pf \cdot Pg + P(Pf \cdot Pg)$$

where  $\alpha$  is a scalar.

A multiplication by  $\alpha^{-1}$  exchanges a linear  $D(\alpha)$ -operator into a  $D'(\alpha)$ -operator, characterized by the functional equation

$$(2) \quad P(fPg + gPf) = P(fg) + (1-\alpha)Pf \cdot Pg + \alpha P(PfPg)$$

A  $D(0)$ -operator is a Reynolds operator and a  $D'(0)$ -operator is called a Baxter operator. To get an insight into such operators, we begin, as in the Reynolds case, by investigating stationary  $D(\alpha)$ -operators over  $C(T_1)$ . We keep the notations used in 7.1.

Theorem 7.3 Let  $\alpha$  be a real number different from 1 and such that  $0 < \alpha < 2$ . Let  $P$  be a stationary bounded linear operator  $P: C(T_1) \rightarrow C(T_1)$  of type  $D(\alpha)$ . Moreover suppose  $P(1) = 1$  and  $P$  transforms real valued functions into real valued functions. Then there exists a real  $\beta$  such that

$$(3) \quad Pf(x) = \alpha \sum_{h=0}^{\infty} (1-\alpha)^h f(x+h\beta)$$

Conversely, Eq (3) furnishes a linear operator of type  $D(\alpha)$ .

Proof As in 7.1,  $P(e_n) = a(n)e_n$  where  $e_n(x) = \exp(inx)$ , for every integer  $n$ . Therefore, due to (1),  $n \rightarrow a(n)$  satisfies the functional equation

$$(4) \quad (a(n) + a(m))a(n+m) = \alpha a(n+m) + (1-\alpha)a(n)a(m) + a(n+m)a(n)a(m).$$

Let us now define three disjoint subsets of  $\mathbb{Z}$ , the set of all integers

$$\Lambda = \{n \in \mathbb{Z}; a(n) \neq 0 \text{ and } a(n) \neq \alpha\}.$$

$$\Lambda_0 = \{n \in \mathbb{Z}; a(n) = 0\}$$

$$\Lambda_\alpha = \{n \in \mathbb{Z}; a(n) = \alpha\}$$

$0 \in \Lambda$  due to our hypothesis  $P(1) = 1$ . If  $a(n+m) = 0$ , then  $a(n)a(m) = 0$  and if  $a(n+m) = \alpha$ , then  $(\alpha - a(n))(\alpha - a(m)) = 0$ . These two properties imply that if  $n$  and  $m$  are in  $\Lambda$ ,  $(n+m)$  is also in  $\Lambda$ . In addition, we get  $a(-n) = \frac{\alpha - a(n)}{1 - (2-\alpha)a(n)}$ , so that  $-n \in \Lambda$  as soon as  $n \in \Lambda$ .

Finally,  $\Lambda$  is a subgroup of  $\mathbb{Z}$  and so  $\Lambda = k\mathbb{Z}$  for some integer  $k$ . We also notice that  $\Lambda_\alpha = -\Lambda_0$ . Moreover, if  $n$  and  $m$  belong to  $\Lambda_0$ , then  $\alpha a(n+m) = 0$  and so  $\Lambda_0$  is a semi-group in  $\mathbb{Z}$ . But if we suppose that 1 does not belong to  $\Lambda$ , then it belongs to either  $\Lambda_0$  or  $\Lambda_\alpha$  and as  $k$  belongs to  $\Lambda$ , we must have  $k = 0$ . There are two cases:

$k = 0$ .  $\Lambda_0 = \mathbb{Z} \setminus [0]$  and  $\Lambda_\alpha = \mathbb{Z}^+ \setminus [0]$  if we suppose, for example, that 1 belongs to  $\Lambda_\alpha$ . With a function  $f$  in  $C(T_1)$ , we associate its

Fourier expansion



$$f \sim \sum_n c_n e^{inx}$$

Due to the assumed continuity of  $P$ , we get the following Fourier expansion for  $Pf$ :

$$Pf \sim c_0 + a \sum_{n>0} c_n e^{inx}$$

But an operator  $R$  defined by  $f \rightarrow Rf \sim \sum_{n \geq 0} c_n e^{inx}$ , is not bounded for the uniform norm according to a theorem due to M. Riesz. This theorem tells us that case  $k = 0$  cannot happen.

$k \neq 0$ . Then  $k = 1$  and  $\Lambda = \mathbb{Z}$ . We rewrite equation (4) and after having defined  $b(n) = \frac{a}{a-1} \left( \frac{1}{a(n)} - \frac{1}{a} \right)$ , we find a simpler equation

$$(5) \quad b(n+m) = b(n)b(m)$$

But to equation (5), we must add  $b(n) \neq 0$  and  $b(n) \neq (1-\alpha)^{-1}$  for all  $n$ . We get, solving (5),  $b(n) = a^n$  where  $a = b(1)$ , and so

$$a(n) = \left( \left(1 - \frac{1}{\alpha}\right) a^n + \frac{1}{\alpha} \right)^{-1}$$

Due to the continuity of the operator  $P$ , we get for the Fourier expansion of  $Pf$

$$Pf \sim \sum_n \left( \left(1 - \frac{1}{\alpha}\right) a^n + \frac{1}{\alpha} \right)^{-1} c_n e^{inx}$$

As stated in the hypothesis of theorem 7.3, we assume that  $P$  conserves real functions, so that, for all  $n$

$$\overline{a(n)} = a(-n) \quad \text{and so} \quad |a| = 1$$

We then define  $a = e^{i\beta}$  where  $\beta$  is a real number and from (5) derive easily a difference equation concerning  $Pf$  which we now denote by

$$Q_{\beta, \alpha} f$$

$$(7) \quad \left(1 - \frac{1}{\alpha}\right) Q_{\beta, \alpha} f(x+\beta) + \frac{1}{\alpha} Q_{\beta, \alpha} f(x) = f(x)$$

This difference equation has at most one solution in  $C(T_1)$ , except when for an integer  $n$ ,  $(1 - \frac{1}{\alpha})e^{in\beta} + \frac{1}{\alpha} = 0$ . But as  $\alpha$  is real, and different from zero, the exceptional cases are  $\alpha = 2$  with  $\beta = \frac{\pi}{n} \pmod{2\pi/n}$ . If then  $0 < \alpha < 2$  and  $\alpha \neq 1$ , equation (7) has a solution given by the following absolutely convergent series

$$Q_{\beta, \alpha} f(x) = \alpha \sum_{k=0}^{\infty} (1-\alpha)^k f(x+k\beta)$$

which we obtained after having taken the inverse of  $\frac{1}{\alpha}(\delta_0 - (1-\alpha)\delta_\beta)$  in the convolution algebra of bounded Radon measures on  $T_1$ . This ends the proof of theorem 7.3.

Note 1. Suppose  $\beta = \alpha\eta$ , then equation (7) can also be written as

$$\frac{Q_{\beta, \alpha} f(x) - Q_{\beta, \alpha} f(x+\alpha\eta)}{\alpha} + Q_{\beta, \alpha} f(x+\alpha\eta) = f(x)$$

When  $\alpha$  tends to zero, we formally get a differential equation for

$$Pf = \lim_{\alpha \rightarrow 0} Q_{\beta, \alpha} f$$

$$(8) \quad -\eta \frac{d(Pf)}{dx}(x) + Pf(x) = f(x)$$

and so  $P$  appears as Reynolds operator  $P_{i\eta}$  according to notation of 37.1. This result might have been foreseen because a  $D(\theta)$ -operator is a Reynolds operator.



**Note 2.** If  $\beta$  is not an ergodic element of  $R \pmod{2\pi}$ , for example  $\beta = \frac{2\pi}{n}$ , then we find that  $Q_{\beta}$   $f$  is a relatively common weighted mean

$$Q_{\beta, \alpha} f(x) = \frac{\alpha}{1 - (1-\alpha)^n} [f(x) + (1-\alpha)f(x - \frac{2\pi}{n}) + \dots + (1-\alpha)^{n-1} f(x - \frac{(n-1)2\pi}{n})]$$

(When  $\alpha$  tends to zero,  $Q_{\beta, \alpha} f(x)$  formally tends towards  $P_n f(x)$  where  $P_n$  is the averaging operator occurring in theorem 7.1).

If  $\beta$  is an ergodic element  $\pmod{2\pi}$ , that is if  $[e^{ik\beta}]_{k \in \mathbb{Z}}$  is dense in the unit circle, then  $Q_{\beta, \alpha} f(x)$  appears to be the Abel summation process of the divergent series  $\sum_{k=0}^{\infty} f(x+k\beta)$ . For a given  $\beta$ ,  $\alpha \rightarrow Q_{\beta, \alpha} f$  is an analytic function of  $\alpha$ .

**Corollary 7.4** Suppose the operator  $Q$  satisfies the hypothesis of theorem 7.3 with  $0 < a < 1$ . Then,  $Q$  is of type  $Q_{\alpha, \beta}$  for an ergodic  $\beta$  if and only if  $Qf(0) = 0$  implies  $f \equiv 0$  for a positive function  $f$ .

If  $\beta$  is ergodic, and  $0 < a < 1$ ,  $Qf(0) = 0$  implies  $f(k\beta) = 0$  for all integers  $k$ , so that  $f \equiv 0$ . The converse is easily derived.

We get  $\|Q_{\alpha, \beta}\| = 1$  for all  $\beta$  and if  $f$  is of bounded variation, we get the following smoothing property

$$V(Q_{\alpha, \beta} f) \leq V(f)$$

However,  $Q_{\alpha, \beta}$  cannot be used as an averaging operator because of the following result:

**Corollary 7.5** An operator satisfying the hypothesis of theorem 7.3 is a bijective operator.

Equation (7) also yields for the uniform norm

$$\|Q_{\beta, \alpha} f\| = \|f\| \text{ for } 1 < \alpha < 2$$

and

$$(\frac{2}{\alpha} - 1)^{-1} \|f\| \leq \|Q_{\beta, \alpha} f\| \leq \|f\| \text{ for } 0 < \alpha < 1$$

Due to (7), the operator  $Q_{\beta, \alpha}$  appears as a multiple of the resolvent of a convolution operator. This operator being the convolution by a Dirac measure  $\delta_{\beta}$

$$Q_{\beta, \alpha} = a(\delta_0 + (\alpha-1)\delta_{\beta})^{-1}$$

Such a Dirac measure  $\delta_{\beta}$  induces a convolution operator  $M$  according to  $Mf = \delta_{\beta} * f$ , and  $M$  is a multiplicative operator:

$$(9) \quad M(fg) = (Mf)(Mg)$$

This last result immediately leads to the following generalization. Let  $M$  be a bounded linear operator on  $C(T_1)$ , satisfying (9). We

suppose that  $(a-1)$  does not belong to the spectrum of  $M$ . Consider (11) an operator  $Q_a$  defined by  $Q_a = a(1+(a-1)M)^{-1}$  which gives:

$$(10) \quad M = \frac{1-aQ_a^{-1}}{1-a}$$

Starting from  $M(Q_a f \cdot Q_a g) = M(Q_a f)M(Q_a g)$ , we get

$$Q_a f Q_a g - a(f Q_a g + g Q_a f) + a^2 fg = (1-a)(Q_a f Q_a g - a Q_a^{-1}(Q_a f Q_a g)) \quad (11)$$

and finally  $Q_a$  appears as an operator of type  $D(a)$ , when we exclude  $a = 0$  and  $a = 1$ . The converse statement is also true, namely if  $Q_a(M)$  is an operator of type  $D(\alpha)$ , for which 1 does not belong to the spectrum,

then (10) furnishes a bounded and multiplicative linear operator.

Theorem 7.4 Let  $Q$  be a bounded linear operator on  $C(T_1)$ . Suppose  $Q(1) = 1$  and suppose that  $Q$  possesses a bounded inverse.  $Q$  is of type  $D(a)$  for  $0 < a < 2$  and  $a \neq 1$  if and only if there exists a continuous  $2\pi$ -periodic function  $\phi: \mathbb{R} \rightarrow \mathbb{R}$  such that

$$Qf = a \sum_{k=0}^{\infty} (1-a)^k f \circ \phi^{(k)}$$

where  $\phi^{(k)}$  denotes the composition of  $k$ -times  $\phi$  by itself.

First, suppose that  $Q$  is  $D(a)$ . Then  $M = \frac{I-aQ}{1-a}$  is a bounded multiplicative operator on  $C(T_1)$  such that  $M(1) = 1$ . Then, for every  $x_0$  in  $T_1$ ,  $f \rightarrow Mf(x_0)$  is a continuous and multiplicative form on  $C(T_1)$  and so  $Mf(x_0) = f(y_0)$  according to a well-known result. (cf bibliography) We write  $y_0 = \phi(x_0)$  and using the continuity of operator  $Q_a$ , we deduce the continuity of  $\phi$ . Then  $Mf = f \circ \phi$ . But we also have

$$(11) \quad (1-a)M = I - aQ^{-1}$$

which yields  $MQ = QM$ , that is

$$(12) \quad Q(f \circ \phi) = Qf \circ \phi$$

Finally we get the following functional equation, by using (11) and (12)

$$(13) \quad (1 - \frac{1}{a})Qf \circ \phi + \frac{1}{a}Qf = f$$

The unique solution in  $C(T_1)$ , within  $0 < a < 2$ , is

$$(14) \quad Qf = a \sum_{k=0}^{\infty} (1-a)^k f \circ \phi^{(k)}$$

Conversely (14) defines an operator  $D(a)$  satisfying the hypothesis of theorem 7.3. We notice that  $Q$  is an isometry for  $1 < a < 2$  and a positive operator for  $0 < a < 1$ .

The generalization of Theorem 7.4 to the case of  $C(X)$ , where  $X$  is a compact Hausdorff topological space is not difficult. It remains to solve the case when  $Q$  is not supposed a priori to possess a bounded inverse.

7.3 Derivation operators

Reynolds operators are closely related to derivation operators. Formally, suppose  $P$  is invertible and is a Reynolds operator. We define the linear operator  $D$  by

$$Df = P^{-1}(f) - f$$

where  $P^{-1}$  is the inverse of operator  $P$ . Then we compute that  $D$  satisfies

$$(1) \quad D(f \cdot g) = Df \cdot g + f \cdot Dg$$

This functional equation (1) is the defining equation of a derivation operator.

It is easy to prove that the only continuous linear and stationary derivation operator  $D: C(T_1) \rightarrow C(T_1)$  is the zero operator.

We start from  $D(e_n) = a_n e_n$ , as previously, due to the property of stationarity. Then Eq (1) yields

$$a_{n+m} = a_n + a_m$$

Therefore, for some  $\lambda$  in  $\mathbb{C}$ ,  $a_n = \lambda n$ . But  $D$  is continuous for the uniform norm, which implies

$$\|D(e_n)\| = |\lambda| |n| \leq \|D\|$$

The only possibility is  $\lambda = 0$  and thus  $D \equiv 0$ .

A classical theorem in analysis states that the property of stationarity plays no part for the result to hold. Namely:

Theorem 7.5 Let  $X$  be a compact Hausdorff space and let  $C(X)$  be the Banach algebra of all complex valued continuous functions over  $X$ . The only linear operator  $D: C(X) \rightarrow C(X)$  which is a derivation is the zero

operator.

By linearity, it is enough to prove that  $D(f) = 0$  for any real-valued  $f$  in  $C(X)$ . Suppose first  $f$  has a square root which is an element of  $C(X)$ , i.e.  $f = g^2$ . Eq (1) yields  $Df = 2gD(g)$ . Therefore, if  $g^2$  is zero at some point  $x_0$  in  $X$ , then so is  $D(g^2)$  at point  $x_0$ . Clearly, any real valued  $f$  in  $C(X)$ , zero at  $x_0$ , can be written as a difference  $g^2 - h^2$  with  $0 = g(x_0) = h(x_0)$ . As a result, for any real valued  $f$  in  $C(X)$ , zero at  $x_0$ ,  $D(f)(x_0) = 0$ . If we let  $1$  be the function everywhere equal to 1 and  $x_0$  be an arbitrary element of  $X$ , we deduce that  $D(f - f(x_0)1)(x_0) = 0$ . But Eq (1) yields  $D(1) \equiv 0$ . Therefore we obtain for any  $x_0$  in  $X$

$$Df(x_0) = 0$$

yielding  $D \equiv 0$ , due to our arbitrary choice of  $x_0$ . Theorem 7.5 can be generalized to any commutative complex Banach algebra, i.e. to an algebra  $A$  which is a complete normed space satisfying the inequality  $\|fg\| \leq \|f\| \|g\|$  for all  $f, g$  in  $A$ . The idea of the generalization works as follows. Let  $\lambda$  be any complex number and suppose first that  $D: A \rightarrow A$  is a linear and bounded derivation operator. We define  $e^{\lambda D}$  as a linear bounded operator:

$$e^{\lambda D} = \sum_{n=0}^{\infty} \frac{\lambda^n D^n}{n!}$$

Let  $\chi: A \rightarrow \mathbb{C}$  be a linear and multiplicative form on  $A$  (cf 2.3). Let us consider

$$Q(\lambda, f) = \chi(e^{\lambda D}(f))$$

We estimate  $Q(\lambda, fg)$

$$\begin{aligned} Q(\lambda, fg) &= \sum_{n=0}^{\infty} \frac{\lambda^n}{n!} \chi(D^n(fg)) \\ &= \sum_{n=0}^{\infty} \lambda^n \sum_{i+j=n} \frac{\chi(D^i(f))}{i!} \frac{\chi(D^j(g))}{j!} \end{aligned}$$

where  $i$ , and  $j$ , are positive integers. Using the absolute convergence of the series (Cauchy's product), we get:

$$= \left( \sum_{n=0}^{\infty} \frac{\lambda^n}{n!} \chi(D^n(f)) \right) \left( \sum_{n=0}^{\infty} \frac{\lambda^n}{n!} \chi(D^n(g)) \right)$$

Therefore, for all  $f, g$  in  $A$

$$(2) \quad Q(\lambda, fg) = Q(\lambda, f)Q(\lambda, g)$$

As in 2.3, it turns out that a non zero linear multiplicative functional in  $A$  is bounded and even of norm 1 (see bibliography).

$$(3) \quad |Q(\lambda, f)| \leq \|f\|$$

But the application,  $\lambda \rightarrow Q(\lambda, f)$ , for any given  $f$  in  $A$ , is an entire function. The majoration (3), combined with Liouville's theorem, implies that  $Q(\lambda, f) = Q(0, f) = 1$ . As a consequence  $\chi(D^n(f)) = 0$  for  $n \geq 1$ . Finally,  $\chi(D(f)) = 0$ , for any linear and multiplicative form on  $A$  and for any  $f$  in  $A$ . In a complex and commutative Banach algebra, the set of all  $f$  in  $A$  such that  $\chi(f) = 0$  for all linear and multiplicative form  $\chi$  on  $A$  is the radical of  $A$ . A semi-simple algebra is an algebra with a radical reduced to the zero element. It is an easy exercise to show that the Banach algebra  $C(X)$  is semi-simple. We thus have proved

Theorem 7.6 The only linear and bounded derivation on a semi-simple complex Banach algebra is the zero operator.

It must be noticed that in Theorem 7.5, no continuity was assumed for  $D$  in contrast with Theorem 7.6. Therefore Th. 7.6 does not contain 7.5 as a particular case. However, it can be proved that Theorem 7.6 remains true without the continuity assumption for the operator of derivation  $D$ . (cf bibliography for such a result and for generalization to the non-commutative case).

7.4 Multiplicatively symmetric operators

In the sequel,  $X$  will be a compact Hausdorff space and  $C(X)$  will be the Banach algebra of all complex valued functions over  $X$ , equipped with the uniform norm. The following result holds (cf bibliography for a proof).

Theorem 7.7 Let  $P: C(X) \rightarrow C(X)$  be a linear, bounded and idempotent operator of norm 1. Suppose that the range of  $P$  contains a strictly positive function. Then for all  $f, g$  in  $C(X)$  the operator  $P$  satisfies:

$$(1) \quad P(f \cdot Pg) = P(Pf \cdot g)$$

Note The condition on the range of  $P$  can be replaced by the following less restrictive one.

If  $e^{i\alpha} Pf(x) = e^{i\alpha'} Pf(x')$  for all  $f$  in  $C(X)$ , then  $x$  (and  $x'$ ) do not belong to the Choquet boundary of the range of  $P$ .

The functional equation (1) is the defining equation of a multiplicatively symmetric operator (which itself is a particular case of multiplicatively related operators).

In the case where  $\|P\| = P(1) = 1$ , and for  $P: C(X) \rightarrow C(X)$ , a multiplicatively symmetric operator coincides with the so-called exaves. We first need a notation to define an exave.

Let  $A, B$  be compact spaces and  $\pi: A \rightarrow B$  be a continuous function. Let  $[\pi]$  denote the linear operator of composition:

$$[\pi]: C(B) \rightarrow C(A)$$

where

$$[\pi](f) = f \circ \pi.$$

A linear exave  $P$  for  $\pi: A \rightarrow B$  is a linear operator  $P: C(A) \rightarrow C(B)$  such that  $[\pi] = [\pi] \circ P \circ [\pi]$ . We shall not prove here the equivalence of linear exaves with multiplicatively symmetric operators (see bibliography) but just sketch some results.

Let  $P$  be a bounded multiplicatively symmetric operator on  $C(X)$ . We define  $A$  to be the set of all  $x$  in  $X$  such that for all  $f, g$  in the algebra  $C(X)$ , we get

$$(2) \quad P(f \cdot Pg)(x) = Pf(x)Pg(x)$$

Such a set  $A$  is called the averaging set of operator  $P$ . When  $P$  is markovian (i.e.  $\|P\| = P(1) = 1$ ), then it can be proved that  $A$  is not empty. We define  $B$  to be a topological quotient space of  $X$ . Namely, an equivalence relation  $P$  on  $X$  is defined according to

$$xPy \text{ if } Pf(x) = Pf(y) \text{ for all } f \text{ in } C(X).$$

Then  $B = X/P$  and  $\pi$  will denote the canonical quotient mapping  $X \rightarrow X/P$ . By  $\tilde{\pi}$  we denote its restriction to  $A$ . We finally define  $\tilde{P}: C(A) \rightarrow C(B)$  according to

$$\tilde{P}g(\pi(x)) = P(\tilde{g}(x))$$

where  $\tilde{g}$  is a given extension of  $g$  into an element of the algebra  $C(X)$ . It happens that  $\tilde{P}$  does not depend upon the choice of the extension for  $g$ . Moreover, it can be proved that  $\tilde{P}$  is a markovian linear exave for  $\tilde{\pi}$ .

Conversely, we associate a multiplicatively symmetric operator with a markovian exave. Let  $A, B$  be two compact Hausdorff topological



spaces and  $\tilde{\pi}: A \rightarrow B$  be a continuous mapping. Denote by  $\tilde{\pi}(A)$  the image of  $A$  through  $\tilde{\pi}$ . Let  $\pi: X \rightarrow B$  be any compact fibre bundle over  $B$ , extending the given fibre bundle  $\tilde{\pi}: A \rightarrow \pi(A)$ . By  $R$ , we shall denote the restriction operator on  $C(X)$ , associated with  $A$

$$R: C(X) \rightarrow C(A) \quad Rf(a) = f(a) \text{ for all } f \text{ in } C(X), a \text{ in } A$$

If we define  $P: C(X) \rightarrow C(X)$  by

$$Pf(x) = \tilde{P}(Rf)(\pi(x))$$

we may prove that  $P$  is a markovian multiplicatively symmetric operator. As in 6.5, we may try to reduce Eq (1) to the superposition of two simpler functional equations. Namely

$$(3) \quad P(f \cdot Pg) = Pf \cdot Pg$$

and

$$(4) \quad P(f \cdot Pg) = P(fg).$$

We keep the notation already introduced.

Proposition 7.2 Let  $P: C(X) \rightarrow C(X)$  be a linear and bounded operator.

Then  $P$  satisfies Eq (3) for all  $f, g$  in  $C(X)$  if and only if for any  $f$  in  $C(X)$  the value of  $Pf$  at any point  $x$  only depends upon the values of  $f$  on the equivalence class  $P(x)$  of  $x$ .

Proof If  $Pf(x)$  only depends upon the values of  $f$  on the equivalence class  $P(x)$  of  $x$ , then as  $Pg$  is constant on  $P(x)$ , we deduce that  $P(f \cdot Pg)(x) = Pf(x)Pg(x)$ , i.e. Eq (3).

Conversely, suppose (3) is satisfied for each  $x$  in  $X$ .

There exists a Radon measure  $\mu_x$  in  $X$  and

$$Pf(x) = \int_X f(y) d\mu_x(y)$$

Eq (3) can therefore be written as

$$0 = \int_X f(y)[Pg(y) - Pg(x)] d\mu_x(y)$$

As  $f$  is arbitrary in  $C(X)$ , we deduce that  $Pg(y) = Pg(x)$  on the support of  $\mu_x$ . In other words,  $Pf(x)$  only depends upon the values of  $f$  on the equivalence class  $P(x)$  of  $x$ . Due to Proposition 7.2, a linear operator satisfying Eq (3) is called an averaging operator.

Let us turn now to Eq (4). By definition, a linear operator satisfying Eq (4) is called an interpolating operator. With any linear operator  $P: C(X) \rightarrow C(X)$  we define its interpolator ( $\text{Int } P$ ) as the subset of all  $x$  in  $X$  such that  $Pf(x) = f(x)$  for all  $f$  in  $C(X)$ . It is generally empty, but never in the case of an interpolating operator.

Proposition 7.3 Let  $P: C(X) \rightarrow C(X)$  be a linear and bounded operator. Then  $P$  is an interpolating operator if and only if for any  $f$  in  $C(X)$  the value of  $Pf$  at any point  $x$  only depends upon the values of  $f$  on the interpolator of  $P$ .

If  $P$  is an interpolating operator, let  $y$  be its interpolator. For each  $x$  in  $X$ , there exists a Radon measure  $\mu_x$  on  $X$  and  $Pf(x) = \int_X f(y) d\mu_x(y)$ . Then Eq (4) yields

$$\int_X f(y)(g(y) - Pg(y)) d\mu_x(y) = 0$$

Therefore  $g(y) = Pg(y)$  for every  $y$  belonging to the support of  $\mu_x$ . In other words, the interpolator of  $P$  is not empty and the values of  $Pf$  at point  $x$  only depend upon the values of  $f$  on the interpolator of  $P$ .



Conversely, let  $P$  an operator with this last property, which implies that  $\text{Int } P$  is not empty. We notice, as  $\text{Int } P$  is a closed subset of  $X$ , that

$$\begin{aligned} P(fPg)(x) &= \int_X f(y)Pg(y)d\mu_X(y) = \int_{\text{Int } P} f(y)Pg(y)d\mu_X(y) = \int_{\text{Int } P} f(y)g(y)d\mu_X(y) \\ &= \int_X f(y)g(y)d\mu_X(y) = P(fg)(x) \end{aligned}$$

An interpolating operator is directly connected with a linear extension operator.

Let  $Y$  be a closed subset of  $X$ . A linear and bounded operator

$E: C(Y) \rightarrow C(X)$  is a linear extension operator relative to  $Y$  if  $Ef(y) = f(y)$  for all  $y$  in  $Y$  and all  $f$  in  $C(Y)$ .

Proposition 7.4 Let  $Y$  be a closed subspace of a compact Hausdorff  $X$ . There exists a linear extension operator relative to  $Y$  if and only if there exists a linear and interpolating operator  $P: C(X) \rightarrow C(X)$  having  $Y$  as its interpolator.

Suppose  $E$  is a linear extension operator relative to  $Y$ . Then for any  $X$  in  $X$ , we get a Radon measure  $\mu_X$  supported by  $Y$  and

$$Ef(x) = \int_Y f(t)d\mu_X(t)$$

Define  $P: C(X) \rightarrow C(X)$  according to

$$Pf(x) = \int_X f(t)d\mu_X(t)$$

The interpolator of  $P$  is easily shown to coincide with  $Y$ . Moreover, by Proposition 7.3,  $P$  is an interpolating operator.

Conversely, let  $P$  be an interpolating operator, with  $Y = \text{Int } P$ .

Then, for any  $f$  in  $C(Y)$ , we define  $Ef = P(\tilde{f})$  where  $\tilde{f}$  is any continuous extension of  $f$  to all of  $X$  (Tietze's extension theorem).

By Proposition 7.3, we notice that  $E$  is a linear and bounded operator and does not depend upon the chosen extension for  $f$ . Moreover  $E$  is a linear extension operator.

An interesting, and still unresolved problem in the general case, is to characterize those compact spaces for which every closed subspace of  $X$  is an interpolator for some interpolating operator on  $C(X)$ . (See bibliography).

Let  $Y$  be a closed subspace of  $X$  and let  $\sim$  be a closed equivalence relation on  $X$ . We denote by  $\tilde{C}(X)$ , identified with  $C(X/\sim)$ , the subalgebra of  $C(X)$  containing all functions which are constant on each class of equivalence. (Same thing with  $\tilde{C}(Y)$ , by restricting  $\sim$  to  $Y$ ). A linear  $q$ -extension operator for  $Y$  and  $\sim$ , is a linear and bounded operator  $Q: \tilde{C}(Y) \rightarrow C(X)$  such that  $Qf(y) = f(y)$  for all  $f$  in  $\tilde{C}(Y)$  and  $y$  in  $Y$ .

With those definitions, multiplicatively symmetric operators can be analyzed (see bibliography).

Theorem 7.8 Let  $P: C(X) \rightarrow C(X)$  be a markovian operator. Then  $P$  is multiplicatively symmetric if and only if

$$P = QoSR$$

where  $R$  is the restriction operator associated with some closed subset  $Y$  of  $X$ .

$S$  is an averaging markovian operator on  $C(Y)$  for which  $S(C(Y)) = R(P(C(X)))$ .

$Q$  is a markovian linear  $q$ -extension operator for  $Y$  and for the equivalence relation  $P$ .

It remains to study multiplicatively symmetric operators in other Banach algebras..

## 7.5 Extreme operators in $L^1$

### 7.5.1 A sketch of the functional analysis background

Roughly speaking, when  $A$  and  $B$  are Banach algebras, the extreme operators, if they exist, of the convex subset of all linear operators  $P: A \rightarrow B$  of norm less than or equal to one, satisfy some functional equation involving the multiplication as defined on  $A$  or  $B$ . For example, it can be proved if  $A$  (respectively  $B$ ) is the Banach algebra of all real-valued continuous functions over a metrizable compact space  $X$  (respectively  $Y$ ), that the set of extreme operators coincide with the set of all operators  $P: C(X) \rightarrow C(Y)$  such that

$$(1) \quad P(1)P(fg) = P(f)P(g) \quad \text{for all } f, g \text{ in } C(X)$$

The functional equation is not, in the general setting, as simple as (1) and sometimes the functional equation only characterizes a subset of all extreme operators. It depends upon topological properties of both  $X$  and  $Y$ . (See bibliography). Quite naturally other spaces  $A$  and  $B$  have been studied and in particular Lebesgue spaces of the  $L^1$ -kind. A generalization of (1) is possible and describes the situation. If we replace the study of extreme points of norm one operators by the study of extreme points of the so-called doubly stochastic operators within the  $L^1$  case, some still unresolved question occur. In order to propose a counter example to some natural conjecture in this setting, J.V. Ryff introduced a functional equation (2), which we shall try to solve here. (We refer the reader to the bibliography for all the background from

functional analysis and for the construction of the functional equation)

$$(2) \quad af(ax) + bf(bx+a) = bf(bx) + af(ax+b)$$

where  $0 \leq x \leq 1$ ,  $a + b = 1$ ,  $0 < a < 1$  and  $a \neq \frac{1}{2}$ . It can be proved that every solution  $f: [0,1] \rightarrow \mathbb{R}$  can be extended to a solution on  $\mathbb{R}$  (i.e. satisfying (2) for all  $x$  in  $\mathbb{R}$ ). In general, these extended solutions are not bounded, although accurate growth estimates are difficult to obtain in general. We shall here study bounded solutions of Eq (2) where  $x$  runs through all of  $\mathbb{R}$ .

#### 7.5.2 Bounded measurable solutions of the functional equation

Theorem 7.9 Let  $0 < a < 1$  and  $a/1-a$  be an irrational number. A bounded Lebesgue measurable  $f: \mathbb{R} \rightarrow \mathbb{C}$  satisfies for all  $x$  in  $\mathbb{R}$  with  $a + b = 1$

$$(2) \quad af(ax) + bf(bx+a) = bf(bx) + af(ax+b)$$

if and only if  $f$  is an almost periodic Bohr function.

Recall that almost periodic Bohr functions were studied in III §5. Notice the weak smoothness assumption made regarding  $f$ . Yet the conclusion stipulates that  $f$  is indeed uniformly continuous. The proof of the theorem will be given, following the establishment of some preliminary results in the theory of tempered distributions.

If  $f$  is defined on  $\mathbb{R}$ , we say that  $f$  has polynomial growth if there exist positive constants  $A$  and  $B$  and a nonnegative integer  $k$  such that

$$|f(x)| \leq A|x|^k + b \quad x \in \mathbb{R}.$$

In particular a bounded function is of polynomial growth. Each such function associates in a canonical way with a tempered distribution  $T_f$  acting on the Schwartz space  $S'$  according to the pairing  $\langle \phi, T_f \rangle = \int_{\mathbb{R}} f(x)\phi(x)dx$ .

Assume that  $f: \mathbb{R} \rightarrow \mathbb{C}$  is a solution to the functional equation (2) for all  $x \in \mathbb{R}$  and that  $f$  is locally Lebesgue integral. We define

$$F(x) = \int_0^x (f(t) - \frac{1}{b-a} \int_a^b f(s)ds) dt \quad \text{and convert (2) into (3)}$$

$$(3) \quad F(ax) + F(bx+a) = F(bx) + F(ax+b)$$

With  $G(x) = F(ax)$  and  $r = b/a$ , we get

$$(4) \quad G(rx+1) - G(rx) = G(x+r) - G(x)$$

Note that  $F$ , hence  $G$ , has polynomial growth whenever  $f$  has this property. Define  $\hat{G}$  to be the Fourier transform of the tempered distribution  $T_G$  associated with  $G$ . The reader will recall that the Fourier transform of a tempered distribution  $u$  in the Schwartz space  $S'$  is defined by  $\hat{u}(\phi) = u(\hat{\phi})$  where  $\phi$  is any element of the space  $S$  of rapidly decreasing functions. The Fourier transform  $\hat{\phi}$  is the canonical one. In addition to this, let  $T_r$  represent the operation of translation by  $r$ :  $(T_r\phi)(x) = \phi(x+r)$ , and denote by  $D_r$  the dilatation operator  $(D_r\phi)(x) = \phi(rx)$ . Equation (4) becomes

$$D_r T_r(T_G) - D_r(T_G) = T_r(T_G) - T_G.$$

Taking the Fourier transform of both sides we obtain

$$(5) \quad \frac{1}{r} D_{\frac{1}{r}}[(e^{iy}-1)\hat{G}] = (e^{iyr}-1)\hat{G}$$

with the understanding that dilatations commute distributions:  $D_\alpha(\hat{G})(\phi) = G(D_\alpha\phi)$ . The same understanding applies to translations. However, if  $h$  is a function of polynomial growth, then define

$$D_\alpha(h\hat{G})(\phi) = (D_\alpha h)(D_\alpha\hat{G})(\phi) = D_\alpha\hat{G}(D_\alpha h\phi) = G(D_\alpha(\widehat{D_\alpha h\phi})) .$$

Apply  $D_r$  to both sides of (5) and use the relation  $D_r D_{\frac{1}{r}} = I$  to obtain

$$(6) \quad \frac{1}{r} (e^{iy-1})\hat{G} = (e^{iyr-1})D_r(\hat{G}) .$$

Then multiply by  $e^{iyr-1}$  and obtain

$$D_r[(e^{iy-1})(e^{iyr-1})\hat{G}] = \frac{1}{r} (e^{iy-1})(e^{iyr-1})\hat{G} .$$

**Proposition 7.5** Any tempered distribution  $T$  with the property that

$D_r T = \frac{1}{r} T$  is a multiple of the Dirac measure at the origin.

Proof. Since  $\langle \phi, D_r T \rangle = \frac{1}{r} \langle D_{\frac{1}{r}} \phi, T \rangle$  for all  $\phi \in S$  and  $D_r T = \frac{1}{r} T$ , we have  $\langle D_{\frac{1}{r}} \phi, T \rangle = \langle \phi, T \rangle$ . If  $\phi \in S$  has compact support and satisfies  $\phi(0) = 0$  then the sequence  $\{D_{(\frac{1}{r})^n} \phi\}_{n=1}^\infty$  converges to 0 uniformly on compact subsets of  $\mathbb{R}$ . Since  $\phi$  has compact support this is the same as convergence to 0 in  $S$ . Therefore  $\lim_{n \rightarrow \infty} \langle D_{(\frac{1}{r})^n} \phi, T \rangle = 0 = \langle \phi, T \rangle$ . The compactly supported functions in  $S$  which vanish at the origin are dense in  $S_0 = \{\phi \in S: \phi(0) = 0\}$ , hence  $\langle \phi, T \rangle = 0$  for all  $\phi \in S_0$ . If  $\phi \in S$  is arbitrary, and  $\psi \in S$  satisfies  $\psi(0) = 1$ , then  $\langle \phi - \phi(0)\psi, T \rangle = 0$ , or

$$\langle \phi, T \rangle = \phi(0) \langle \psi, T \rangle, \text{ i.e. } T = \langle \psi, T \rangle \delta_0 .$$

We conclude that

$$(e^{iy-1})(e^{iyr-1})\hat{G} = \lambda \delta_0$$

for some  $\lambda \in \mathbb{C}$ .

The roots of  $(e^{iy-1})(e^{iyr-1}) = 0$  constitute the set  $2\pi\mathbb{Z} \cup \frac{2\pi}{r}\mathbb{Z} = E$ .

Assume that  $r$  is irrational so that these roots are all simple. If  $y_0$  does not belong to  $E$  choose  $\phi \in S$  whose support is compact, does not intersect  $E$  and  $\phi(y_0) \neq 0$ . Then  $\psi(y) = \phi(y)[(e^{iy-1})(e^{iyr-1})]^{-1}$  lies in  $S$  and

$$\langle \phi, \hat{G} \rangle = \langle \psi, (e^{iy-1})(e^{iyr-1})\hat{G} \rangle = \lambda \psi(0) = 0 .$$

Therefore, the support of  $\hat{G}$  lies in  $E$ . Assume now that  $y \in E$ ,  $y \neq 0$ , and that  $\phi \in S$  again has compact support in a neighborhood of  $y_0$  intersecting no other point of  $E$ . Let  $\psi$  be any other function in  $S$  with the same properties as  $\phi$  with the additional property that  $\psi(y_0) = 1$ . Then  $\theta = [\phi - \phi(y_0)\psi] \cdot [(e^{iy-1})(e^{iyr-1})]^{-1} \in S$  and still lies in  $S$  because of the simple zeros in the denominator. Hence,

$$\begin{aligned} \langle \phi, \hat{G} \rangle &= \phi(y_0) \langle \psi, \hat{G} \rangle + \langle (e^{iy-1})(e^{iyr-1})\theta, \hat{G} \rangle \\ &= \langle \psi, \hat{G} \rangle \langle \phi, \delta_{y_0} \rangle + \lambda \theta(0) = \langle \psi, \hat{G} \rangle \langle \phi, \delta_{y_0} \rangle . \end{aligned}$$

Thus  $\hat{G}$  is locally a multiple of the Dirac measure  $\delta_{y_0}$ .

Any distribution with support  $\{0\}$  must be a combination of the Dirac distribution and its derivatives at the origin. Thus, for appropriate complex constants  $\{a_k\}_{k=1}^n$ ,  $\{\lambda_k\}_{k \in \mathbb{Z}}$ ,  $\{\lambda'_k\}_{k \in \mathbb{Z}}$  we have

$$\hat{G} \sim \sum_{k=0}^n a_k \delta_0^{(k)} + \sum_{k \neq 0} \lambda_k \delta_{2\pi k} + \sum_{k \neq 0} \lambda'_k \delta_{\frac{2\pi k}{r}}$$

The sign  $\sim$  means that equality holds locally or, equivalently, if  $\phi \in \mathcal{S}$  has compact support then  $\langle \phi, \hat{G} \rangle$  is computed by applying the right-hand side of the relation to  $\hat{\phi}$ .

If  $\phi \in \mathcal{S}$ , we have from (6) by suitable change of variable

$$\langle (e^{iy}-1)\phi, \hat{G} \rangle = \langle (e^{yr}-1)D_{\frac{1}{r}}\phi, \hat{G} \rangle.$$

Suppose that  $\phi$  is compactly supported and that its support intersects  $E$  at zero only. Then  $\hat{G} \sim \sum_{k=0}^n a_k \delta_0^{(k)}$  and

$$(7) \quad \sum_{k=0}^n a_k [(e^{iy}-1)\phi]_{y=0}^{(k)} = \sum_{k=0}^n a_k [(e^{iyr}-1)D_{\frac{1}{r}}\phi]_{y=0}^{(k)}.$$

Comparing the coefficients of  $\phi^{(n-1)}(0)$  we find that

$$na_n = na_n r^{2-n}$$

since  $\phi$ , and the first  $n$  derivatives of  $\phi$ , are at our disposal. It follows that  $a_n = 0$  when  $n > 2$ . Considering the case  $n = 2$ , we obtain from (7)

$$(1-r)\phi(0)[ia_1 - (r+1)a_2] = 0$$

so that  $(1+r)a_2 = ia_1$ , with the constant  $a_0$  arbitrary. By definition we have  $\langle \hat{G}, \phi \rangle = \langle G, \hat{\phi} \rangle$ , hence if  $\phi$  has support intersecting  $E$  at zero only

$$\langle G, \hat{\phi} \rangle = \frac{1}{\sqrt{2\pi}} \int_{-\infty}^{\infty} [a_0 + a_1 iy - \frac{a_1 i}{1+r} y^2] \phi(y) dy$$

or,

$$G \sim \beta + \gamma(x-x^2)$$

(since  $a+b=1$ ) where  $\gamma$  and  $\beta$  are arbitrary scalars.

Only the polynomial growth of  $f$  has been used up to this point. If, in addition,  $f$  is bounded, then the arbitrary constants  $a_0$  and  $a_1$  are clearly equal to zero. Define  $\hat{H}$  to be the tempered distribution which represents  $\hat{G}$  away from the origin:

$$\hat{H} \sim \sum_{k \neq 0} \lambda_k \delta_{2\pi k} + \sum_{k \neq 0} \lambda'_k \delta_{\frac{2\pi k}{r}}$$

For any  $\phi \in \mathcal{S}$  with compact support

$$\langle \phi, \hat{H} \rangle = \langle \hat{\phi}, H \rangle = \sum_{k \neq 0} [\lambda_k \hat{\phi}(2\pi k) + \lambda'_k \hat{\phi}(\frac{2\pi k}{r})].$$

It follows by uniqueness of the Fourier transform on  $\mathcal{S}'$  that  $H$  is given by a function (also called  $H$ ) defined (locally) by

$$H(x) = \sum_{k \neq 0} [\lambda_k e^{-2\pi i k x} + \lambda'_k e^{\frac{-2\pi i k}{r} x}].$$

Since  $H$  has polynomial growth, the convolution of  $H$  with any  $\phi \in \mathcal{S}$  exists



and we have formally:

$$(8) \quad \psi(x) = \int_{\mathbb{R}} H(x-t)\phi(t)dt = \sum_{k \neq 0} [\lambda_k \hat{\phi}(2\pi k)e^{ikx} + \lambda'_k \hat{\phi}(\frac{2\pi k}{r})e^{irkx}] .$$

In order to obtain equality for all  $\phi \in S$  we need some estimates regarding the  $\lambda_k$  and the  $\lambda'_k$ . For example, consider  $\hat{\phi}_n \in S$  with  $\hat{\phi}_n(2\pi n) = 1$ ,  $0 \leq \hat{\phi}_n \leq 1$ , and the support of  $\hat{\phi}_n$  equal to some interval around  $2\pi n$  intersecting no other points of  $E$ . We may use

$$\hat{\phi}_n(x) = \exp\left[1 - \frac{1}{1 - \frac{(x-2\pi n)^2}{\epsilon_n^2}}\right]$$

for  $|x - 2\pi n| < \epsilon_n$ , and  $\hat{\phi}_n(x) = 0$  where  $\epsilon_n$  is chosen sufficiently small.

Then

$$\langle \hat{\phi}_n, \hat{H} \rangle = \lambda_n \hat{\phi}_n(2\pi n) = \int_{\mathbb{R}} \hat{\phi}_n(x)H(x)dx$$

so that

$$|\lambda_n| \leq A \int_{\mathbb{R}} |\hat{\phi}_n(x)| \cdot |x|^k dx + B \int_{\mathbb{R}} |\hat{\phi}_n(x)| dx .$$

In order to estimate these integrals, we need to restrict  $\epsilon_n$ . By virtue of the nonintersection requirement and the irrationality of  $r$ ,  $\epsilon_n$  can be chosen so that

$$\left| \frac{n}{q} - r \right| \geq \frac{1}{2\pi} \frac{\epsilon_n}{q}$$

for all nonzero integers  $q$ .

By writing  $\int_{\mathbb{R}} |\hat{\phi}_n(x)| dx$  as  $\epsilon_n \int_{-1}^1 \exp(1 - \frac{1}{1-t^2}) dt$  and  $\int_{\mathbb{R}} |\hat{\phi}_n(x)| \cdot |x|^k dx$

as  $\epsilon_n \int_{-1}^1 \exp(1 - \frac{1}{1-t^2}) |\epsilon_n t - 2\pi n|^k dt$  we get a majoration of  $|\lambda_n|$  by a polynomial in  $n$  and  $\epsilon_n$ . It follows that  $|\lambda_n|$  is majorized by a certain power of  $n$ . This proves that (8) is valid for all  $\phi \in S$  since  $|\hat{\phi}(2\pi k)|$  and  $|\hat{\phi}(\frac{2\pi k}{r})|$  tend to zero faster than any negative power of  $k$ . The series in (8) is uniformly convergent and proves that  $\psi$  is almost periodic. By approximating the Dirac measure appropriately at the origin with functions  $\phi_k \in S$  we obtain a sequence of almost periodic functions  $\{H * \phi_k\}_{k=1}^{\infty}$  converging on  $\mathbb{R}$  to  $H$ . Since  $H$  is uniformly continuous, the convergence will be uniform so that  $H$  is also an almost periodic Bohr function.

Remark. Theorem 7.9 is certainly true if we only assume that  $f$  has polynomial growth in place of boundedness. The difficulty lies in showing that  $H$  is uniformly continuous or that we may subtract a polynomial from  $G$  in such a way that the remainder is bounded.

Now we proceed to study almost periodic solutions of (2). In order to simplify the statement of the next theorem, we introduce this definition.

Definition 7.2 Let  $r$  be a nonzero real number. Let  $H: \mathbb{R} \rightarrow \mathbb{R}$  and  $G: \mathbb{R} \rightarrow \mathbb{R}$  be continuous periodic functions of period one such that the Fourier coefficient of order 0 is 0 ( $c_0(G) = c_0(H) = 0$ ). The pair  $(H, G)$  is a pair of  $r$ -associated functions if for all  $x$  in  $\mathbb{R}$  we get

$$(9) \quad H(x+r) - H(x) = G(x + \frac{1}{r}) - G(x) .$$

It is not difficult to exhibit  $r$ -associated pairs. We may construct a family



of  $r$ -associated pairs depending upon an arbitrary function of period 1.

Let  $t: \mathbb{R} \rightarrow \mathbb{R}$  be of period 1 and let

$$H(x) = t\left(x + \frac{1}{r}\right) - t(x)$$

and

$$G(x) = t(x+r) - t(x).$$

Clearly, the pair  $(H, G)$  is an  $r$ -associated pair. However, it is worth noticing that all  $r$ -associated pairs do not arise in such a single way as shall be proved later.

Theorem 7.10 Let  $f: \mathbb{R} \rightarrow \mathbb{R}$  be an almost periodic Bohr function. A function  $f$  satisfies Eq. (2) for all  $x \in \mathbb{R}$ , with  $b \neq 0$  and  $\frac{a}{b}$  irrational, if and only if there exists an  $\frac{a}{b}$  associated pair of functions  $(h, g)$ , and a constant  $f_0$  such that for all  $x$  in  $\mathbb{R}$

$$f(x) = f_0 + \frac{1}{b} h\left(\frac{x}{b}\right) + \frac{1}{a} g\left(\frac{x}{a}\right).$$

Proof of the sufficiency.\*

$$\begin{aligned} af(ax) + bf(bx+a) &= (a+b)f_0 + \frac{a}{b} h\left(\frac{a}{b}x\right) + g(x) + h\left(\frac{bx+a}{b}\right) + \frac{b}{a} g\left(\frac{bx+a}{a}\right) \\ &= (a+b)f_0 + \frac{a}{b} h\left(\frac{ax+b}{b}\right) + h(x) + g\left(\frac{ax+b}{a}\right) + \frac{b}{a} g\left(\frac{b}{a}x\right) \end{aligned}$$

by using  $h(x+1) = h(x)$  and  $h\left(\frac{bx+a}{b}\right) - h(x) = g\left(\frac{ax+b}{a}\right) - g(x)$  which is Eq. (9)

with  $r = \frac{a}{b}$

$$= bf(bx) + af(ax+b).$$

\* With the hypothesis made in Theorem 7.10, the writing of  $f(x) = f_0 + \frac{1}{b} h\left(\frac{x}{b}\right) + \frac{1}{a} g\left(\frac{x}{a}\right)$  is unique.

Moreover,  $f$  being a linear combination of continuous periodic functions is an almost periodic Bohr function. This proof does not require  $\frac{a}{b}$  to be irrational.

Proof of the necessity. Let us suppose that  $f$  is an almost periodic Bohr solution of Eq. (2). As any constant function is a solution of Eq. (2), we consider the primitive

$$F(x) = \int_0^x (f(t) - c_0(f)) dt$$

where  $c_0(f)$  is the Fourier coefficient of order 0 of  $f$ .

By integrating Eq. (2), we get a new functional equation

$$F(ax) + F(bx+a) - F(a) = F(bx) + F(ax+b) - F(b).$$

Due to a classical result, as we subtracted from  $f$  its zero Fourier coefficient, the function  $F$  is also an almost periodic Bohr function.

Now take  $r = \frac{a}{b}$  and define  $G(x) = F(bx)$ . The function  $G: \mathbb{R} \rightarrow \mathbb{R}$  is also an almost periodic Bohr function, and satisfies the following functional equation.

$$(10) \quad G(rx+1) - G(rx) + G(r) = G(x+r) - G(x) + G(1).$$

We now multiply both members of Eq. (10) by  $e^{iwx}$ , for any real nonzero  $w$ , integrate from  $-T$  to  $+T$ , divide by  $2T$  and let  $T$  tend to infinity. This yields, with  $w \neq 0$

$$(11) \quad \left(e^{i\frac{w}{r}} - 1\right) c_{wr}(G) = \left(e^{iwr} - 1\right) c_w(G).$$

Multiplying by  $wr, wr^2, \dots$ , instead of  $w$ , and simplifying we get

$$(e^{iwr^n} - 1)(e^{iwr^{n-1}} - 1) c_{wr^{n-1}}(G) = (e^{iw} - 1)(e^{iwr} - 1) c_w(G), \quad n = 0, 1, 2, \dots$$

But  $|(e^{iwr^n} - 1)(e^{iwr^{n-1}} - 1)| \leq 4$ , while  $\lim_{p \rightarrow \infty} c_{wr^{n-1}}(G) = 0$  if  $|r| > 1$

or  $\lim_{p \rightarrow \infty} c_{wr^{n-1}}(G) = 0$  if  $|r| < 1$  for all  $w \neq 0$  because  $\sum_{w \in S_p(G)} |c_w(G)|^2$

is convergent and  $|r| \neq 1, r \neq 0$ . Thus we get

$$(12) \quad (e^{iw} - 1)(e^{iwr} - 1) c_w(G) = 0.$$

From Eq. (12), we deduce that the spectrum of  $G$  is included in  $E (= 2\pi\mathbb{Z} \cup \frac{2\pi}{r}\mathbb{Z})$

If we suppose  $w = 2\pi n$ , for a given  $n$  in  $\mathbb{Z}$ , Eq. (11) gives back:

$$c_{2\pi n}(G)[e^{2i\pi nr} - 1] = c_{\frac{2\pi n}{r}}(G)[e^{2i\pi \frac{n}{r}} - 1].$$

The formal generalized Fourier series associated with  $G$  can now be written

in the following form, as  $r$  is an irrational number:

$$G(x) = c_0(G) + \sum_{n \neq 0} c_{2\pi n}(G) \left[ e^{2i\pi nx} + \frac{e^{2i\pi nr} - 1}{e^{2i\pi \frac{n}{r}} - 1} e^{2i\pi \frac{n}{r} x} \right].$$

Consider now the formal trigonometric series

$$\sum_{n \neq 0} c_{2\pi n}(G) e^{2i\pi nx}.$$

Such a formal trigonometric series is in fact the Fourier series associated

with a continuous function  $H_1$  of period one. For the proof, we have to make use of the following more general lemma (with  $\Lambda = 2\pi\mathbb{Z}$ ) concerning a special case of idempotent multipliers for Fourier series (cf bibliography).

Lemma 7.3 Let  $G: \mathbb{R} \rightarrow \mathbb{R}$  be an almost periodic Bohr function and  $\Lambda$  be a subgroup of  $(\mathbb{R}, +)$ . The formal generalized trigonometric series

$$\sum_{w \in \Lambda} c_w(f) e^{cwx}$$

is associated with an almost periodic Bohr function.

Using the Lemma with

$\Lambda = 2\pi\mathbb{Z}$ , we get that  $H_1 + c_0(G)$  is continuous, and so is  $H_1$  itself.

We in fact may obtain a little more concerning function  $H_1$ . By our construction,  $G$  possesses a continuous and almost periodic derivative. So does  $H_1$ . For the proof, it is enough to see that  $c_w(G') = iw c_w(G)$  for  $w \neq 0$  and by using the previous lemma

$$\sum_{n \neq 0} (2i\pi n) c_{2\pi n}(G) e^{2i\pi nx}$$

is the Fourier series associated with some continuous function  $H^{(1)}$ . We easily conclude that  $\frac{dH_1}{dx}(x) = H^{(1)}(x)$ , using for instance Fejer's Theorem. Thus  $H_1$  has a continuous derivative (which is an almost periodic Bohr function). In the same way, up to a change of variable ( $x$  into  $rx$ ), the formal trigonometric series

$$\sum_{n \neq 0} c_{2\pi n}(G) \frac{e^{2i\pi nr} - 1}{e^{2i\pi \frac{n}{r}} - 1} e^{2i\pi nx}$$

is associated with a continuous function  $H_2$  of period 1 and of class  $C^1$ . By the uniqueness theorem for the representation of almost periodic Bohr functions, we may now write

$$G(x) = H_1(x) + H_2\left(\frac{x}{r}\right) + c_0(G)$$

However, we compute easily that  $H_1(x+r) - H_1(x)$  and  $H_2\left(x+\frac{1}{r}\right) - H_2(x)$  have the same generalized Fourier coefficients and so are equal. We conclude that the pair  $(H_1, H_2)$  is an  $r$ -associated pair and that  $c_0(H_1) = c_0(H_2) = 0$ . Let us now go back to  $F(x)$ .

$$F(x) = H_1\left(\frac{x}{b}\right) + H_2\left(\frac{x}{a}\right) + c_0(G).$$

As  $H_1$  and  $H_2$  are functions of class  $C^1$ , we obtain

$$f(x) = f_0 + \frac{1}{b} h\left(\frac{x}{b}\right) + \frac{1}{a} g\left(\frac{x}{a}\right)$$

where  $f_0 = c_0(f)$ ;  $h(x) = H_1'(x)$  and  $g(x) = H_2'(x)$ . In the same way,  $h$  and  $g$  are continuous functions of period 1,  $c_0(h) = c_0(g) = 0$  and so  $(h, g)$  is an  $r$ -associated pair. This ends the proof of Theorem 7.10.

Corollary 7.6 Let  $a + b = 1$ ,  $a \neq b$ ;  $a \neq 0$ ;  $a \neq 1$ . There exists a family  $f^{(j), j_0}$  of almost periodic Bohr solutions of Eq. (2), depending upon an arbitrary continuous function  $j$  of period  $ab$  and an arbitrary real constant  $j_0$ .

$$f^{(j), j_0}(x) = a[j(ax+b) - j(ax)] + b[j(bx+a) - j(bx)] + j_0.$$

This corollary, via some computation, is a simple consequence of our Theorem 7.10 thanks to our way of exhibiting  $\frac{a}{b}$ -associated pairs. It should be noted that we made use of  $a+b=1$  in the Corollary just to use  $b^2 = b \pmod{ab}$ . Such an hypothesis was not required for Theorem 7.10 to be valid. It also should be noticed that  $f^{(j), j_0} = f^{(j'), j'_0}$  for continuous  $j, j'$  and constants  $j_0, j'_0$  if and only if  $j = j'$  and  $j_0 = j'_0$  as soon as  $\frac{a}{b}$  is irrational. In general, all almost periodic solutions of Eq. (2) are not of the form  $f^{(j), j_0}$  for some continuous function  $j$  of period  $ab$  and some constant  $j_0$ . We shall give a counterexample. But before that we begin with another theorem giving the general continuous solution of Eq. (2) when  $\frac{a}{b}$  (or  $\frac{b}{a}$ ) is an integer. We could use a device similar to the one used in Theorem 7.10, but prefer a direct approach which is itself interesting from a functional equation point of view.

Theorem 7.11 Let  $b = \frac{1}{n+1}$  (or  $a = \frac{1}{n+1}$ ) where  $n$  is a given integer greater than or equal to 2. Let  $f: [0, 1] \rightarrow \mathbb{R}$  be a Riemann integrable function. The function  $f$  satisfies Eq. (2) if and only if there exists a constant  $\alpha$  and a function  $k: \mathbb{R} \rightarrow \mathbb{R}$ , periodic and of period  $\frac{1}{n+1}$ , locally Riemann integrable, such that for all  $x$  in  $[0, 1]$ , we have

$$f(x) = \alpha x + k(x).$$

Proof. We take  $b = \frac{1}{n+1}$ , so that  $a = \frac{n}{n+1}$  and  $\frac{a}{b} = n$ . We define a new function  $\alpha(x) = f\left(\frac{x}{n+1}\right)$  where  $\alpha: [0, n+1] \rightarrow \mathbb{R}$  and get for all  $x \in [0, 1]$ .

$$(13) \quad \alpha(x+n) - \alpha(x) = n[\alpha(nx+1) - \alpha(nx)].$$

It is noticeable that for any real constants  $\beta$  and  $\gamma$ ,  $\beta x + \gamma$  is a solution of Eq. (2). Thus we can always assume, without loss of generality, that function  $\alpha$  has been chosen in such a way that  $\alpha(0) = \alpha(n+1) = 0$ . It is easy to see that this implies  $\alpha(1) = \alpha(n) = 0$ . We now make a new change of function by introducing

$$F(x) = \alpha(x+n) - \alpha(x)$$

where  $F: [0,1] \rightarrow \mathbb{R}$ . We then get with Eq. (13) and for all  $x \in [0,n]$

$$\frac{1}{n} F\left(\frac{x}{n}\right) = \alpha(x+1) - \alpha(x).$$

By induction, we obtain

$$(14) \quad \frac{1}{n} \left[ F\left(\frac{x}{n}\right) + F\left(\frac{x+1}{n}\right) + \dots + F\left(\frac{x+n-1}{n}\right) \right] = F(x).$$

Now, by iteration, we decompose each term of the left member of Eq. (14)

$$\begin{aligned} F\left(\frac{x}{n}\right) &= \frac{1}{n} \left[ F\left(\frac{x}{n^2}\right) + F\left(\frac{x+n}{n^2}\right) + \dots + F\left(\frac{x+n^2-n}{n^2}\right) \right] \\ &\vdots \\ F\left(\frac{x+n-1}{n}\right) &= \frac{1}{n} \left[ F\left(\frac{x+n-1}{n^2}\right) + F\left(\frac{x+n-1+n}{n^2}\right) + \dots + F\left(\frac{x+n-1+n^2-n}{n^2}\right) \right]. \end{aligned}$$

By summing up vertically all such equations, we get

$$F(x) = \frac{1}{n^2} \left[ F\left(\frac{x}{n^2}\right) + F\left(\frac{x+1}{n^2}\right) + \dots + F\left(\frac{x+n^2-1}{n^2}\right) \right].$$

More generally, we deduce by induction that for all integers  $k$

$$F(x) = \frac{1}{n^k} \sum_{i=0}^{i=n^k-1} F\left(\frac{x+i}{n^k}\right).$$

However the function  $F$ , as well as  $f$ , is Riemann-integrable on  $[0,1]$  so that we obtain the following relation

$$F(x) = \int_0^1 F(t) dt.$$

Thus  $F$  is a constant function, which is the zero function due to the assumed boundary conditions. Coming back to  $\alpha$ , we see that

$$\alpha(x+n) - \alpha(x) = 0 \quad \text{for all } x \text{ in } [0,1]$$

and

$$\alpha(x+1) - \alpha(x) = 0 \quad \text{for all } x \text{ in } [0,n].$$

This leads to

$$f\left(x + \frac{1}{n+1}\right) = f(x) \quad \text{for all } x \text{ in } \left[0, \frac{n}{n+1}\right].$$

We may then extend  $f$  into a periodic function  $k$ , of period  $\frac{1}{n+1}$  over  $\mathbb{R}$ , which ends the proof of Theorem 7.11.

With  $b = \frac{1}{n+1}$ , we deduce that the general almost periodic Bohr solution of Eq. (2) is a continuous function of period  $\frac{1}{n+1}$  because almost periodic functions are bounded functions and so the  $\alpha$  appearing in Theorem 7.11 must be

equal to zero. Now, if there were to be a  $j$  such that  $f(x) = f^{(j), j_0}(x)$  with  $j$  of period  $\frac{n}{(n+1)^2}$  and a constant  $j_0$ , this would mean

$$f(x) = j_0 + (1 - \frac{1}{n+1}) [j((1 - \frac{1}{n+1})x + \frac{1}{n+1}) - j((1 - \frac{1}{n+1})x)] + \frac{1}{n+1} [j(\frac{x}{n+1} + 1 - \frac{1}{n+1}) - j(\frac{x}{n+1})].$$

But as  $j$  is of period  $\frac{n}{(n+1)^2}$ , it is also of period  $\frac{n}{n+1} = 1 - \frac{1}{n+1}$  so that

$$f(x) = j_0 + (1 - \frac{1}{n+1}) [j((1 - \frac{1}{n+1})x + \frac{1}{n+1}) - j((1 - \frac{1}{n+1})x)].$$

But then we may compute an average according to

$$f(x) + f(x + \frac{1}{n}) + \dots + f(x + \frac{n-1}{n}) = nj_0 + (1 - \frac{1}{n+1}) [j((1 - \frac{1}{n+1})x + \frac{n}{n+1}) - j(1 - \frac{1}{n+1})x]$$

$j$  having  $\frac{n}{n+1}$  as a period, and we obtain the following

$$\frac{f(x) + \dots + f(x + \frac{n-1}{n})}{n} = j_0.$$

Although the function  $f$  is a continuous function of period  $\frac{1}{n+1}$ , it is not true in general that  $\frac{f(x) + \dots + f(x + \frac{n-1}{n})}{n}$  should be a constant. Such an

average is constant if and only if the spectrum of  $f$ , which is included in  $(n+1)2\pi\mathbb{Z}$ , has an intersection with  $2\pi n\mathbb{Z}$  which reduces to  $\{0\}$ . This proves that  $f$  in general cannot be of the form  $f^{(j), j_0}$ . However, there exists for any  $f$  which is  $\frac{1}{n+1}$  periodic, an  $n$ -associated pair  $(h, g)$ , and a constant  $f_0$  such that

$$f(x) = f_0 + (n+1)h((n+1)x) + \frac{n+1}{n} g(\frac{n+1}{n}x).$$

We first may take  $f_0 = c_0(f)$ ,  $h \equiv 0$  and  $g(x) = \frac{n}{n+1} (f(\frac{n}{n+1}x) - c_0(f))$ . Thus  $g$  is a continuous function of period  $\frac{1}{n}$  with  $c_0(g) = 0$  and so  $(0, g)$  is an  $n$ -associated pair. We thus have proved

Theorem 7.12 Theorem 7.10 remains true when  $\frac{a}{b}$  (or  $\frac{b}{a}$ ) is an integer greater than or equal to 2.

Note. When  $\frac{a}{b}$  is irrational, the expression of  $f(x)$  as  $f_0 + \frac{1}{b} h(\frac{x}{b}) + \frac{1}{a} g(\frac{x}{a})$  where  $(h, g)$  is an  $\frac{a}{b}$  associated pair is unique. To see this, it is enough to make use of the lemma. We could have added a uniqueness result to Theorem 7.10. However, this is no longer true for Theorem 7.12 when  $\frac{a}{b}$  is rational. Summarizing our conclusions for both the rational and irrational case we have

Theorem 7.13 Let  $a$  and  $b$  be nonzero real numbers such that  $\frac{a}{b} \neq \pm 1$ . A function  $f \in AP(\mathbb{R})$  satisfies (2) if and only if there exists  $(h, g)$ , an  $\frac{a}{b}$ -associated pair and a constant  $f_0$  such that

$$f(x) = \frac{1}{b} h(\frac{x}{b}) + \frac{1}{a} g(\frac{x}{a}) + f_0.$$

It only remains to prove the general rational case and the necessity of the given formula (even though it may not be unique). From (12) it still follows that  $SpG \subset E$  and

$$(15) \quad c_{2\pi n}(G)(e^{2i\pi nr} - 1) = c_{\frac{2\pi n}{r}}(G)(e^{\frac{2i\pi n}{r}} - 1).$$

Suppose  $r = \frac{p}{q}$  where  $p$  and  $q$  are relatively prime. Equation (15) gives us some nullity results. If  $n$  is a multiple of  $q$  without being a multiple of  $r$ , then  $c_{\frac{2\pi n}{r}}(G) = 0$ . Analogously, if  $n$  is a multiple of  $p$  without being a multiple of  $q$ , then  $c_{2\pi n}(G) = 0$ . Thus we may write the Fourier series associated with  $G$  in the following form:

$$\begin{aligned} G \sim & \sum_{\substack{n \in p\mathbb{Z} \cup q\mathbb{Z} \\ n \in \mathbb{Z}}} c_{2\pi n}(G) \left[ \frac{e^{2i\pi nx} - e^{\frac{2i\pi n}{q}x} - 1}{e^{2i\pi n \frac{q}{p}x} - 1} e^{2i\pi n \frac{q}{p}x} \right] \\ & + \sum_{n \in pq\mathbb{Z}} [c_{2\pi n}(G)e^{2i\pi nx} + c_{2\pi n \frac{q}{p}}(G)e^{2i\pi n \frac{q}{p}x}] \\ & + \sum_{n \in p\mathbb{Z} \setminus q\mathbb{Z}} c_{2\pi n \frac{q}{p}}(G)e^{2i\pi n \frac{q}{p}x} + \sum_{n \in q\mathbb{Z} \setminus p\mathbb{Z}} c_{2\pi n}(G)e^{2i\pi nx}. \end{aligned}$$

In the last three sums, all terms have their spectrum in  $q\mathbb{Z}$ . Using the lemma, we see that they represent an almost periodic Bohr function. The same is true of the first sum. Reapplying the lemma, with  $\Lambda = \mathbb{Z}$ , to the first term, we find that the following function  $F$  is continuous of period 1:

$$F(x) \sim \sum_{\substack{n \in p\mathbb{Z} \cup q\mathbb{Z} \\ n \in \mathbb{Z}}} c_{2\pi n}(G)e^{2i\pi nx}.$$

In the same way, so is

$$J(x) \sim \sum_{\substack{n \in p\mathbb{Z} \cup q\mathbb{Z} \\ n \in \mathbb{Z}}} c_{2\pi n}(G) \frac{e^{\frac{2i\pi n}{q}x} - 1}{e^{2i\pi n \frac{q}{p}x} - 1} e^{2i\pi nx}.$$

Moreover,

$$F(x + \frac{p}{q}) - F(x) = J(x + \frac{q}{p}) - J(x)$$

so that  $(F, J)$  are  $\frac{p}{q}$ -related. The three other terms can be grouped as a single function  $H$  in  $AP(\mathbb{R})$ :

$$H(x) \sim \sum_{k \in \mathbb{Z}} c_{2\pi kq}(G)e^{2i\pi kqx}$$

which is, in fact, a  $\frac{1}{q}$ -periodic continuous function. Consequently,

$$G(x) = F(x) + J(\frac{q}{p}x) + H(x).$$

Differentiating this expression we obtain

$$G'(x) = \frac{1}{a} g(\frac{x}{a}) + \frac{1}{b} f(\frac{x}{b}) + h(x)$$

where  $h(x) = \frac{1}{b} H'(\frac{x}{b})$  has period  $\frac{b}{q} = \frac{a}{p}$  and completes the proof, since we can easily replace  $h(x)$  by  $\frac{1}{a} g_1(\frac{x}{a}) + \frac{1}{b} f_1(\frac{x}{b}) + f_0$ .

Finally, we state without proof

**Theorem 7.14** Let  $f \in AP(\mathbb{R})$ . Then  $f$  satisfies (2) with  $a \neq -b$ ,  $a \neq 0$  if and only if  $f$  is the sum of a continuous  $a$ -periodic function and an odd almost periodic function.

**Note.** Even in the case  $a = -b$ , Theorem 7.13 remains valid provided we drop the requirement that the functions be of period one in the definition of  $r$ -associated pairs.



7.5.3 Some open problems. The following problem naturally arises.

Problem 1. Is it possible that for some values of  $\frac{a}{b} = r$ , all solutions of Eq. (2) could be written as  $f^{(j)}, j_0$ ? We have seen that this cannot be the case for  $r = \frac{1}{n}$  or  $r = n$  ( $n \geq 2$ ). We may guess that this cannot be the case for a rational  $r$ . However, if  $r$  is irrational, we should have

$$\begin{aligned} f^{(j)}, j_0 &= j_0 + \frac{1}{b}(j(ax+b) - j(ax)) + \frac{1}{a}(j(bx+a) - j(bx)) \\ &= f_0 + \frac{1}{b}h\left(\frac{x}{b}\right) + \frac{1}{a}g\left(\frac{x}{a}\right). \end{aligned}$$

As  $r$  is irrational and as  $j(ax+b) - j(ax)$  has period  $b$ , we may once more use our lemma to deduce that

$$j_0 + \frac{1}{b}(j(ax+b) - j(ax)) = f_0 + \frac{1}{b}h\left(\frac{x}{b}\right),$$

and in the same way

$$j_0 + \frac{1}{a}(j(bx+a) - j(bx)) = f_0 + \frac{1}{a}g\left(\frac{x}{a}\right).$$

But  $c_0(h) = c_0(g) = 0$ , as  $(h, g)$  is an  $r$ -associated pair. Thus

$$f_0 = j_0$$

$$h\left(\frac{x}{b}\right) = j(ax+b) - j(ax)$$

and

$$g\left(\frac{x}{a}\right) = j(bx+a) - j(bx).$$

We define  $J(x) = j(ax)$  and so  $J$  has 1 as a period. Then

$$h(x) = J\left(x + \frac{1}{a}\right) - J(x)$$

and

$$g(x) = J\left(x + \frac{1}{b}\right) - J(x).$$

But  $a+b = 1$  so that  $r+1 = \frac{1}{b}$  and  $1 + \frac{1}{r} = \frac{1}{a}$ .  $J$  being of period 1, we may also write

$$(16) \quad \begin{cases} h(x) = J\left(x + \frac{1}{r}\right) - J(x) \\ g(x) = J(x+r) - J(x). \end{cases}$$

Equation (16) easily implies that  $(h, g)$  is an  $r$ -associated pair. Problem 1 is now equivalent to the following.

Problem 2. For which irrational  $r$ 's is it true that all  $r$ -associated pairs  $(h, g)$  can be written in the form of Eq. (16) for some  $J: \mathbb{R} \rightarrow \mathbb{R}$  of period 1?

(Let us recall that  $h$  and  $g$  are supposed to be continuous by definition of an  $r$ -associated pair.)

Let  $r$  be an irrational number. If  $f$  and  $g$  are trigonometric polynomials of period one and of degree less than or equal to  $N$ , it is not difficult to see that  $(h, g)$  is an  $r$ -associated pair if and only if there exists some trigonometric polynomial  $J_N$ , of period one and of degree less than or equal to  $N$ , such that (16) holds. Now, Fejér's theorem amounts to saying that for any continuous function  $h$  of period 1, the expression

$$h_N(x) = h * F_N(x) = \sum_{n=-N}^{n=+N} c_n(h) \left(1 - \frac{|n|}{N}\right) e^{2i\pi nx}$$

uniformly converges towards  $h$ , where  $F_N$  is the Fejér kernel.

If then  $(h, g)$  is an  $r$ -associated pair, so is  $(h * F_N, g * F_N)$ . As  $h * F_N$  and  $g * F_N$  are trigonometric polynomials of period one and of degree less than or equal to  $N$ , there exists a  $J_N$  such that

$$h * F_N = J_N(x + \frac{1}{r}) - J_N(x)$$

$$g * F_N = J_N(x + r) - J_N(x)$$

where  $J_N$  is a trigonometric polynomial of period one and of degree less than or equal to  $N$ . Moreover, as  $r$  is irrational, an immediate application of Theorem 7.9 shows that  $J_N$  is unique. Our Problem 2 (or 1) is solved if the following one is solved:

Problem 3. For which irrational numbers  $r$ , if any, is it true that the uniform convergence of  $J_N(x + \frac{1}{r}) - J_N(x)$  and of  $J_N(x + r) - J_N(x)$  implies the uniform convergence of  $J_N$ ?

In fact, if  $J_N$  uniformly converges towards some  $J$ , necessarily a continuous and periodic function of period 1, we immediately get Eq. (10).

We shall just add one comment here to give some insight concerning Problem 3. Let us denote by  $\tilde{C}[0,1]$  the Banach space of all complex valued and continuous functions  $f$ , of period one and such that  $c_0(f) = 0$ , equipped with the uniform norm. For any nonzero real  $r$  we define a difference operator  $D_r$

$$D_r f(x) = f(x+r) - f(x).$$

$D_r$  is a linear and bounded operator from  $\tilde{C}[0,1]$  into  $\tilde{C}[0,1]$ . It is a

one-to-one operator if and only if  $r$  is irrational as can easily be seen. The image of  $\tilde{C}[0,1]$  under  $D_r$ , for an irrational  $r$  is a proper subspace of  $\tilde{C}[0,1]$ . To prove this, by contradiction, suppose  $D_r(\tilde{C}[0,1]) = \tilde{C}[0,1]$ . Then using the open mapping theorem, there should exist an  $\alpha > 0$  and

$$\alpha \|f\|_\infty \leq \|D_r f\|_\infty.$$

With  $f(x) = \exp(2i\pi nx)$ , this leads for all  $n \in \mathbb{Z}$ ,  $n \neq 0$ , to

$$|e^{2i\pi \frac{n}{r}} - 1| \geq \alpha.$$

But this contradicts the density of the sequence  $\{e^{2i\pi \frac{n}{r}}\}_{n \in \mathbb{Z} \setminus \{0\}}$  on the unit circle. One can easily verify that  $D_r(\tilde{C}[0,1])$  is a proper dense subspace of  $\tilde{C}[0,1]$ .

If Problem 3 has a positive solution for some  $r$ , it seems reasonable to guess that  $r$  and  $\frac{1}{r}$  are not algebraically related, like transcendental numbers for example.

INDEX OF NOTATIONS AND SYMBOLS

$a, b; \alpha, \beta$	generally constants
$A$	constant
$A$	class of functions 3.5; an algebra 7.1
$\alpha_H$	4.4
$\aleph_0, \aleph_1$	cardinal numbers 4.3
$B$	class of functions 2.5
	or normed space 4.4
$B$	set of characters 3.5
$B, *$	Bohr group of $\mathbb{R}$ 3.5
$C$	class of functions 4.1
$\complement E$	The complement of a subset $E$ 1.2
$C_1$	a cone in the plane $\mathbb{R}^2$ 3.6
$C_{g,h}$	3.6
$C(T_k)$	algebra of continuous $2\pi/k$ periodic functions 7.11
$C_0(\mathbb{R})$	1.2
$C(x_0, y_0, r)$	a disc 4.2
$C_R(X)$	7.12
$C_b(\mathbb{R})$	3.5
$C(x)$	7.2
$C(E)$	a class of functions 4.1, 4.9
$\Delta$	a subgroup 4.7
$\Delta, \Delta^*$	binary laws 6.6
$\Delta(\vec{V})$	7.1
$\delta$	a rational number 3.7
$\text{div}(\vec{V} \otimes \vec{V})$	7.1
$D_r(T)$	7.5
$E$	a Lebesgue measurable subset of $\mathbb{R}$ 1.2
$E$	a class of functions 3.1
$E$	a normed space 4.9
$e_0, e_1, e_2, e_3$	5.1 Example 2
$e_\lambda$	$e_\lambda(x) = \exp(i\lambda x)$ 3.5, 7.1
$E_n$	4.3
$\epsilon, \epsilon', \epsilon''$	5.2
$\epsilon(x_1, x_2)$	$Q$ -linear span of $x_1, x_2$ 4.4
$\epsilon(E)$	$Q$ -linear span of $E$ (Property 4) 4.3

$\phi$	function 4.7
$f$	function 7.2
$\phi(h)$	$h$ -th iterate of $\phi$ 7.2
$\bar{f}$	4.3
$f^\wedge$	Fourier transform of $f$ 2.3; 3.5
$F(E)$	4.3 Property 1
$\tilde{f}$	4.2
$F$	in general a group, or a function. Except in Chapter 4, where it denotes a subset.
$F; F'$	families 4.1; 4.3
$G, *$	a group
$G$	a group or a function like in 6.1; 6.2; 2.2; 2.4; 3.6; 3.7).
$G^\wedge$	dual group of $G$ 3.5
$G_Z$	some subgroup of $G$ 3.1
$g^n$	$g^n(x) = g(g^{n-1}(x))$
$\tilde{g}$	4.1
$\Gamma$	a subsemi group of $\mathbb{R}$ 4.7
$\Upsilon$	constant
$(\Upsilon, a, b); (\Upsilon, S)$	special types 6.2
$H$	subgroup of $G$ (except 2.2; 3.6; 6.1; 6.2 where it denotes a function and 4.3 where it denotes a Hamel basis).
$H_E$	4.3
$\tilde{h}$	3.1; 6.5
$I$	6.6 interval of $\mathbb{R}$
$I_{\text{Loc}}$	5.5
$I$	6.2
$J$	6.2
$K$	a function in 2.1
$\kappa$	a function in 4.5; a subset in 4.6 and also a field
$\chi_E$	a subset
$X$	characteristic function of $E$ 1.2
$X$	3.5; 7.3
$\text{Ker } f$	kernel of $f$ 3.3
$L^1(\mathbb{R})$	Lebesgue space 1.2; 1.6
$L^1(\Omega, F, \mu)$	measure space 2.6; 7.5
$\wedge$	a divisible subgroup of $\mathbb{R}$ 4.7

$\wedge, \wedge_0, \wedge_\phi$	subsets of $\mathbb{Z}$ 7.2
$m, n$	integers
$m(E)$	Lebesgue measure of $E$ 1.2
$M(E)$	4.3 property 7
$M(f)$	mean of $f$ 3.5
$\mu_x$	Radon measure 7.4
$N$	The set of natural integers (1,2,3,...)
$N_0$	$N \cup \{0\}$
$nX$	6.2
$nE$	4.3
$0$	neutral element of an (additive) group
$P_h$	7.11
$P$	3.5.1
$P(A)$	probability of an event $A$ 2.6
$P; \tilde{P}, P^*$	equivalence relations 6.6
$\pi_I, \pi_H, \pi', \pi$	epimorphisms 3.2; 6.5
$P_1, P_2$	4.2
$Q$	The set of rational numbers
$Q_+^*$	$Q \cap ]0, \infty[$
$Q^+$	$Q \cap [0, \infty[$
$Q(E)$	$Q$ -convex hull of $E$ (Def. 4.6)
$Q_{\beta, \alpha}$	an operator 7.2
$\mathbb{R}_+^*$	The usual topological set of all real numbers ( $\mathbb{R}$ )
$\mathbb{R}_+^*$	$]0, \infty[$
$\mathbb{R}^+$	$[0, \infty[$
$R_E$	4.3; Property 2.
$R$	equivalence relation 6.6
$R_\infty, R_S$	7.1.1
$S_x$	6.2
$S$	semigroup 2.5
$s(g(x))$	2.5
$\emptyset$	non empty open subset 1.1
$\bar{T}$	$\mathbb{R}/2\pi\mathbb{Z}$ 2.1
$\bar{T}_h$	$\mathbb{R}/2\pi h\mathbb{Z}$ 7.1

$T(X)$	a triangle 4.2
$t(Z)$	a subset of $G$ 4.1; 4.2
$\tau, \tau\tau, \tau'$	proper linearly invariant ideals 5.6
$V$	some neighbourhood
$x, y$	elements of $F$ or $G$
$x^\wedge$	character 3.5
$(X, g)$	4.1
$X$	subsemi-group of $G$ 4.1 full subset of $G$ 4.2 normed space 4.5
$X'$	5.3; 5.6
$(Y, g)$	4.1
$Y_0$	4.1
$Y$	subsemi-group of $G$ 4.1; 4.2
$Y_x$	5.6
$Z$	subset of $G \times G$ 3.1
$Z^*$	lemma 3.1
$Z_x; Z'_x$	5.6
$Z'$	complement of $Z$ in $G$ (Chapter 6)
$Z'$	translate of $Z$ 4.2
$\mathbb{Z}$	set of all integers
$(Z, G, F)$	condition 3.1
$1$	neutral element in a group
$  $	6.1
$\xi, \zeta$	liftings 6.2; 3.2; 3.3
$*, \underline{1}$	binary laws 6.6
$\perp$	orthogonal relation on a normed space 4.9
$\langle, \rangle$	scalar product 4.5; 4.9
$*$	binary law 6.5; 6.6
$\square$	binary law 6.6
$f * g$	convolution 1.2
$\langle \phi, T \rangle$	7.5

## SUBJECT INDEX

additive function 1.5
additive function in number theory 4.7
alternative equation 5.2
almost redundant condition 5.6
Apollonius identity 2.5
associative law 2.1
automorphism 1.3
averaging operator Corollary 7.1 ; 7.3
averages 7.1
averaging set 7.4
almost periodic Bohr function 3.5 ; 7.5
Baire category 3.2
Baire property 3.2
Baire's theorem (Theorem 3.3) 3.2
Banach algebra 2.3
Baxter operator 7.3
Bohr almost periodic function 3.5
Bohr compactification 3.5
Bohr group 3.5
Cantor ternary set 3.2 ; 4.3
Cauchy functional equation 1.1 ; 1.5 for the definition
Cauchy inequality 1.6
Cauchy's nucleus 3.4
Cauchy solution 1.5
character 3.5
compatible equivalence relation 6.6
conditional Cauchy equation relative to $Z$ 3.1
conjugate ideals 5.6
convex decomposition 6.2
$C$ - quasi redundant 4.1
$C$ - quasi redundancy 4.8
convolution operator 7.2
derivation 1.4
derivation operator 7.3
Dirac measure 7.5
distribution theory 7.1
division model 6.1
dyadic numbers 4.4
$D(\mathfrak{d})$ - operator 7.2
$D'(\mathfrak{d})$ - operator 7.3
doubly stochastic operator 7.5
$E$ -redundant 3.1
Erdős theorem Theorem 3.12
Euler equation 6.2
Euler function 3.7
exave 7.4
extension of homomorphisms
extreme operators 7.5
Fejér's theorem 7.1
Full subset of a divisible group 4.2

Gauss' functional equation 2.1  
 general solution of the Cauchy equation Theorem 4.6  
 geometrical objects 6.2  
 Gergonne's problem 6.2

Haar measure 3.2 ; 3.5  
 Hamel bases definition 4.5  
 Hausdorff's maximality theorem 4.1 ; 4.3  
 homomorphism 1.5 ; 3.4

idempotent operator 7.1 ; 7.4  
 idempotence equation 6.2  
 information function 2.6  
 inner product 4.9  
 interpolating operator 7.3  
 interpolator 7.3  
 invariant ideal 5.6  
 involution equation 6.2  
 iterative  $\mathcal{I}$ -decomposition 6.2  
 iterative convex decomposition 6.2

Jensen convex function 2.4 ; 4.6  
 Jensen functional equation 2.4

Lifting 6.5 ; 6.6  
 linear extension operator 7.3  
 linear  $q$ -extension operator 7.3  
 linear iteration of order two 6.2

Markovian operator 7.4  
 mean 3.5  
 Mikusinski functional equation 2.2 ; 5.1  
 Minkowski gauge 6.2  
 monoid 6.6  
 $M$ -quasi redundancy 4.7  
 multiplicative function 1.5  
 multiplicative operator 7.2  
 multiplicative symmetry 6.5  
 multiplicatively symmetric operator Prop. 7.1 ; 7.2

Navier-Stokes equation 7.1

polynomial growth 7.5  
 positive Lebesgue measure 1.2  
 projections 4.2  
 proper linearly invariant set ideal 3.1  
 Pythagora's theorem 4.9

quasi-extension 4.2  
 quasi-group 6.6  
 quasi-redundancy 4.1  
 $Q$ -convex 4.1 (definition 4.1) ; 4.3  
 $Q$ -convex hull definition 4.6  
 $Q$ -radial 4.1 (definition 4.2) ; 4.3

radical of an algebra 7.3  
 $r$ -associated functions 7.5  
 rectangle 3.1  
 redundant conditions 3.1  
 regular iterative  $\mathcal{I}$ -decomposition 6.2  
 retract 6.2  
 right cylinder 3.1  
 right regular monoid 6.6  
 Reynolds operator 7.1

semi-group 4.1 a set and an associative binary law  
 semi-simple algebra 7.3  
 Shannon entropy 2.6  
 square 3.1  
 spectrum of an algebra 2.3  
 stationary operator 7.1  
 Stone-Weierstrass theorem 2.3, 7.1  
 Strictly convex normed space 2.5  
 subadditive functions 1.6  
 subgroup of index 2 5.1  
 suradditive functions 1.6

tempered distribution 7.5  
 totally disconnected spaces Th. 7.2, lemma 7.2  
 triangle 3.1, 4.2  
 tubular condition 3.1, 5.5  
 turbulence theory 7.1  
 types of Cauchy conditional equations 3.1

uniform norm 3.5

$Z$ -additive function 3.1  
 $Z$ -multiplicative function 3.1



BIBLIOGRAPHICAL INDICATIONS

There are two basic references for functional equations. Both references contain an almost exhaustive bibliography up to their date of publication. Both books are easily accessible and make no use of sophisticated results. The first one is :

J. ACZÉL - Lectures in functional equations and their applications  
Mathematics in Science and Engineering  
Academic Press New York 1966

The second one is more specialized :

M. KUCZMA - Functional equations in a single variable  
Monografie Matematyczne Warszawa 1968

Another general book on functional equation is available in romanian :

M. GHERMĂNESCU - Ecuatii functionale Bucarest 1960

For systematic current references concerning functional equations, it is best to consult the periodical "Aequationes Mathematicae", published since 1968 (by University of Waterloo, Ontario, Canada, edited by Birkhäuser Verlag, Basel, Switzerland).

An introduction to functional equations can be read in :

E. HILLE - Topics in classical analysis  
Lectures in Modern Mathematics, Vol III  
Wiley and Sons New York 1965

or in a chapter of the handbook of mathematical psychology :

R. BELLMAN - Functional equations  
Handbook of Mathematical Psychology, Vol III  
Wiley and Sons New York 1965

Another presentation uses functional equations for some basic mathematics :

J. TODD, O. TAUSSKY - Functional equations  
Mimeographed notes of the Department of Mathematics  
California Institute of Technology, 1974/75  
revised in 1978.

Outside the previous references, we shall provide the reader with some bibliographical information chapter by chapter.

Chapter I

Theorem 1.2. and Lemma 1.1. appeared frequently in various publications as soon as the Lebesgue theory was spread. Note the role played by the Polish school. A non exhaustive list of papers, in their order of appearance, is the following :

Seemingly, the first paper to prove that a Lebesgue measurable and additive  $f: \mathbb{R} \rightarrow \mathbb{R}$ , is continuous, is the following :

M. FRECHET - L'enseignement mathématique (1923), XV, p. 390-393

Later, came the proof that if E is of positive Lebesgue measure in  $\mathbb{R}$ , the set of all x-y where x, y are in E, contains a segment [0, a] for some  $a > 0$  :

H. STEINHAUS - Sur les distances de points dans les ensembles de mesure positive Fund. Math 1 (1920) p. 93-104

Frechet's result was proved without Hausdorff's maximality theorem and adapted also to the case  $\mathbb{R}^2$  (it can be deduced from Th 4.9)

W. SIERPINSKI - Sur l'équation fonctionnelle  $f(x+y) = f(x) + f(y)$  Fund. Math 1 (1920) p. 116-121

(The proof in  $\mathbb{R}^2$  can even be generalized so that, to suppose only  $f(x, y_0)$  and  $f(x_0, y)$  to be Lebesgue measurable for some  $(x_0, y_0) \in \mathbb{R}^2$ , still yield the continuity).

Another short proof, based on Lusin's theorem (for all  $\delta > 0$ , any Lebesgue measurable  $f: [a, b] \rightarrow \mathbb{R}$  is continuous except perhaps on a set of Lebesgue measure less than  $\delta$ ; it uses Hausdorff's maximality theorem), appeared simultaneously in :

S. BANACH - Sur l'équation fonctionnelle  $f(x+y) = f(x) + f(y)$  Fund. Math 1 (1920) p. 123-124

Then comes Lemma 1.1 proved on  $\mathbb{R}^n$  and applied to various cases.

A. OSTROWKI - Über die Funktionalgleichung der Exponentialfunktion und verwandte Funktionalgleichungen Jahresbericht Deutsch. Math. Verein 38 (1929) p.54-62

Later, two other proofs of the continuity of a Lebesgue measurable additive function  $f: \mathbb{R} \rightarrow \mathbb{R}$  appeared in :

M. KAC - Une remarque sur les équations fonctionnelles Comm. Math. Helv. 9 (1936/37) p. 170-171

Various circumstances under which Lemma 1.1. and analogous Lemmata hold were thoroughly studied in :

S. PICCARD - Sur les ensembles de distances des ensembles de points d'un espace euclidien Gauthier-Villars 1939

and, S. PICCARD - Sur des ensembles parfaits, Université de Neuchâtel 1942 (194 p.)

.../

Another proof then appeared, of the continuity of a measurable additive function  $f: \mathbb{R} \rightarrow \mathbb{R}$  :

A. ALEXIEWICZ - On a functional equation of Cauchy W. ORLICZ - Fund. Math. 33 (1945) p. 314-315

and later, a second proof, the one we chose for lemma 1.1.

H. KESTELMAN - On the functional equation  $f(x+y) = f(x) + f(y)$  Fund. Math. 1947 p. 144-147

Another generalization, with measurable stochastic processes appeared in :

B. NAGY - On a generalization of the Cauchy equation Aeq Math (1974) 10 p.165-170

Various generalizations of Theorem 1.2 (convex situations) are studied in Chapter IV, § 4,5 and 6. Further references will be found in the bibliography for Chapter IV. Another extension is given in :

V. DROBOT - Generalized Cauchy equations in groups Aeq Math 5 (1970) p. 120-122

Corollary 1.4 is common folklore.

Corollary 1.5 is a generalization of results which appeared in :

S. KOTZ - On the solutions of some isomoment functional equations Amer. Math. Monthly 72 (1965) p. 1072-1075

J. ACZÉL - General solutions of "isomoment" functional equations Amer. Math. Monthly 74 (1967) p. 1068-1071

and,

J. ACZÉL and P. FISCHER - Some generalized "isomoment" equations and their general equations Amer. Math. Monthly 75 (1968) p. 952-957

Proposition 1.1 and generalizations can be found in :

W.B. JURKAT - On Cauchy's functional equations Proc. Amer. Math. Soc. (1965) 16 p. 683-686

S. KUREPA - Remarks on the Cauchy Functional equation Publ. Inst. Math. Beograd 5(19), 85-88 (1965)

A. NISHIYAMA and S. HORINOUCI - On a system of functional equation Aeq. Math. vol. 1 no. 1 p. 1-5 (1968)

Pl. KANNAPPAN and S. KUREPA - Some relations between additive functions I. Aeq. Math. 4 (1970) p. 163-175 II. Aeq. Math. 6 (1971) p. 46-58

J. VAN DER MARK - On the functional equation of Cauchy Aeq. Math. 10 (1974) p. 57-77

Derivations have been studied in so many instances, both in algebra and in functional analysis, and still constitute an important subject of research. At the level of this exposition, a simple construction of non trivial derivations is to be found in :

S.L. SEGAL - Aeq. Math. vol. 2 (1969) P28R1 p.111-112

A basic reference is :

.../

P. SAMUEL - Commutative algebra I, II Van Nostrand 1958  
O. ZARISKI

More is known nowadays, and some references will be given in chapter VII for linear derivation operators.

Some functional equations were proved to be equivalent to Cauchy equation. For example, if a field  $K$  has at least five elements, a function  $f: K \rightarrow \Gamma$  where  $\Gamma$  is a group, which satisfies the Hosszu functional equation :

$$f(x+y-xy) = f(x) + f(y) - f(xy) \quad x, y \in K$$

satisfies, in fact, Cauchy's equation up to a constant (is affine)

$$f(x+y) + f(0) = f(x) + f(y) \quad x, y \in K$$

See,  
T.M.K. DAVISON - The complete solution of Hosszu's functional equation over a field  
Aeq. Math. (1974) 11 p. 273-276

and the references quoted in this paper.

Cauchy's inequality, or suradditive functions (or its opposite, sub-additive function, i.e.  $f(x+y) \leq f(x) + f(y)$ ) have been intensively studied for the needs of functional analysis. The best, and encyclopedic, reference when  $f: \mathbb{R} \rightarrow E$  for a normed space  $E$ , is the following book :

E. HILLE - Functional analysis and semigroups  
R.S. PHILLIPS - American Math. Soc; Coll. publ. no.31 1957 808 pages

See also the following short papers

S. MARCUS - Un critère de finitude pour les fonctions sous-additives  
Comptes Rendus Acad. Sc. Paris 244 (1957) p.2221-2222

S. MARCUS - Critères de majoration pour les fonctions sous-additives, convexes ou internes  
Comptes Rendus Acad. Sc. Paris 244 (1957) p. 2270-2272

.../

Chapter II

Gauss'functional equation was treated by :

P. LEVY - Théorie de l'addition des variables aléatoires, Paris 1937

We chose this example mainly as an introduction to conditional Cauchy equations.

Mikusinski's introduction of his functional equation appeared in Polish papers, but there are a number of papers on this functional equation published in English. We refer, for this and for all references in conditional Cauchy equations, to the exhaustive bibliography of the following survey paper :

Marek KUCZMA - Functional equations on restricted domains  
Aeq. Math. (1978) 18 p. 1-34

Functional equations on restricted domains is another, if longer name, for conditional functional equations.

For the "almost everywhere" Cauchy equation, more will be said in Chapter V §6. For the spectrum of  $L^1(\mathbb{R})$ , see :

L.H. LOOMIS - Introduction to abstract harmonic analysis  
Van Nostrand, 1953

Jensen's functional equation is common folklore, it has a geometrical significance in preserving midpoints. See the bibliography in Aczél's monography. As it is related to Jensen convex functions, see chapter IV §6 and the bibliographical references quoted there. Naturally, the classical and wonderful book :

G.H. HARDY - Inequalities  
G. PÓLYA - Cambridge Univ. Press  
J.E. LITTLEWOOD 1934 (and 1952 for the second edition)

always provides useful information.

The generalized Cauchy equations dealt with in 2.5 was treated by many authors. Let us mention some references. See the already mentioned survey paper of M. KUCZMA or the next reference for more bibliographical details.

P. FISCHER, G. MUSZÉLY On some new generalizations of the functional equation of Cauchy  
Canadian Math. Bull. 10 (1967), 197-205

In this paper, Theorem 2.8, Th. 2.9 and Th. 2.10 were proved. Amongst the earlier papers are :

E. VINCZE - Über eine Verallgemeinerung der Cauchyschen Funktionalgleichung, Funkcialaj Ekvacioj 6 (1964) p.55-62

E. VINCZE - Beitrag zur Theorie der Cauchyschen Funktionalgleichungen  
Archiv der Math. 15 (1964)p.132-135

Corollary 2.1 was also obtained in a simpler way for a group  $G$  in :

H. SWIATAK - On the functional equation  $(f(x+y))^2 = (f(x)+f(y))^2$   
Publ. Techn. Univ. Miskole 30 (1970) 303-309

.../

It must be mentioned that the first proof for continuous functions  $f: \mathbb{R} \rightarrow \mathbb{R}$  if due to M. HOSSZÚ in 1963 and was published in hungarian :

M. HOSSZÚ - Egy alternativ függvényegyenletről  
Mat Lapok 14 (1963) 98-102

Some generalizations of Corollary 2.1, the proofs of which are postponed to Chapter V, first appeared in :

P. FISCHER - Sur l'équivalence des équations fonctionnelles  
 $f(x+y)=f(x)+f(y)$  et  $(f(x+y))^2 = (f(x)+f(y))^2$   
Ann. Fac. Sc. Toulouse 1968 p.71-73

and were improved by :

M. KUCZMA - On some alternative functional equations  
Aeq. Math 17 (1978) p. 182-198

More references for generalizations shall be provided with the bibliography given for Chapter V.

For information theory and functional equations, the best reference is :

J. ACZÉL - On measures of information and their characterizations  
Z. DARÓCZY Academic Press, 1975

Chapter III

A classification of Conditional Cauchy equations appeared for the first time in :

J. DHOMBRES, R. GER - Equations de Cauchy conditionnelles  
Comptes Rendus Acad. Sc. Paris 280, 1975, p. 513-515

and proofs were given in the following paper by the same authors :

J. DHOMBRES, R. GER - Conditional Cauchy Equations - Glasnik Math.(1978)  
Vol 13 (33) p.39-62

A general survey for conditional equations recently appeared in :

M. KUÇZMA - Functional equations on restricted domains  
Aeq. Math. (1978) 18 p.1-34

See also for some proofs :

G. MÉHAT - Equations de Cauchy conditionnelles  
DEA de mathématiques, Université de Nantes 1976

Corollary 3.1 uses Lemma 1.1 for which we have already given a long bibliography. Another reference is useful :

J.H.B. KEMPERMAN - A general functional equation  
Trans. Amer. Math. Soc. 86 (1957) p. 28-56

Corollary 3.2, based on the result on  $\mathbb{R}$ , concerning the interior of  $E + E$  when only topological conditions of the Baire category type are given, appeared in the already quoted paper by S. PICCARD. Generalizations to topological linear spaces are numerous. See amongst others :

Z. KOMINEK - On the sum and the difference of two sets in topological spaces  
Fund. Math. 71 (1971) p. 165-169

Z. CIESIELSKI - Some remarks on the convergence of functionals on bases  
W. ORLICZ Studia Math. 16 (1958) p. 335-352

L. DUBIKAJTIS, C.FERENS, R. GER, M. KUCZMA - On Mikusinski's functional equation  
Annales Polonici Math. 28 (1973) p. 39-47

R. GER - On an alternative functional equation  
Aeq. Math. 15 (1977) p. 145-162

A. BECK - The interior points of the product of two subsets of a locally compact group  
Proc.Am. Math. Soc. 9 (1958) p. 648-652

M. KUCZMA - On a theorem of R. GER  
Prace Matematyczne VI (1975) p. 73-75

W. SAUNDERS - Verallgemeinerungen eines Satzes von S. PICCARD  
Manuscripta Math. 16 (1975) p. 11-25

W. SAUNDERS - Verallgemeinerungen eines Satzes von H. STEINHAUS  
Manuscripta Math. 18 (1976) p. 101-103

A.S. BESICOVITCH - On the set of distances between points of a general metric space  
S.J. TAYLOR Proc. Cambridge Phil. Soc. 1952 (48) Part. 2 p.209-214

Lemma 1.1 was nicely generalized to some Radon measures on  $\mathbb{R}$ , instead of the Lebesgue measure :

M. KUCZMA, J. SMÍTAL - On measures connected with the Cauchy equation  
Aeq. Math. 14 (1976) p. 421-428

See also for regularity results for conditional Cauchy equations of type I :

J. TABOR - Solutions of Cauchy's functional equation on a restricted domain  
Coll. Math. 23 (1975) p. 203-208

J. TABOR - Continuous solutions of Cauchy's functional equation on a restricted domain  
To appear in Aeq. Math.

A. GRZĄSLEWICZ - On extensions of homomorphisms  
Aeq. Math. (to appear)

and for some other applications :

K. LAJKÓ - Applications of extensions of additive functions  
Aeq. Math (1974) 11 p.68-76

A sort of converse theorem to Th. 3.4 appeared in :

A. GRZĄSLEWICZ - On Cauchy's nucleus  
Z. POWAZKA, J. TABOR Publ. Math. Debrecen Tome 25 Fasc. 1-2 (1978) p. 47-51

Corollary 3.5 is a generalization of a result of :

A.R. SCHWEIZER - A bifurcative generalization of a functional equation due to Cauchy  
Bull. Amer. Math. Soc. 22 (1915) p. 294

The application to extension of homomorphisms appeared in :

J. DHOMBRES - On some extension of homomorphisms  
Nanta Math. vol. X no. 2 p. 135-141 1977

Bohr groups appear as a particular case of duality in topological groups which is at the very heart of harmonic analysis. The encyclopedia in the domain is :

E. HEWITT, K.A. ROSS - Abstract Harmonic Analysis - Vol 1,2  
Springer Verlag 1963, 1969

Shorter but deep introductions are :

A. WEIL - L'intégration dans les groupes topologiques  
Hermann 1940

W. RUDIN - Fourier analysis on Groups  
Interscience Publishers 1962

L.H. LOOMIS - An introduction to abstract harmonic analysis  
Van Nostrand 1953

A reference for the Diophantine result used in the construction of the Bohr group of  $\mathbb{R}$  is :

G.H. HARDY, E.M. WRIGHT - An introduction to the theory of numbers (4th ed)  
Clarendon Press 1964

The first author to have investigated Cauchy conditional equations along curves seems to have been :

M. ZDUN - On the uniqueness of solution of the functional equation  
 $\varphi(x+f(x)) = \varphi(x) + \varphi(f(x))$   
Aeq. Math. 8 (1972) p. 229-232

Lemma 3.2 and Corollary 3.6 are due to Zdun - Theorem 3.10 is an improvement of a result of :

M. KUCZMA - A characterization of the exponential and logarithmic functions by functional equations  
Fund. Math. 52 (1963) p. 283-288

Theorem 3.11 was first proved for some use in the theory of information in :

J. ACZÉL, Z. DARÓCZY - Charakterisierung der Entropien positiver Ordnung und der Shannonschen Entropie  
Acta Math. Acad. Sc. Hung. 14 (1963) p. 95-121

See also a proof as a consequence of Theorem 3.12 :

J. ACZÉL, Z. DARÓCZY - On measures of information and their characterizations  
Academic Press 1975

Th. 3.11 is proved here in a different way as a consequence of Th. 3.2. It would be interesting to deduce Theorem 3.12 from Theorem 3.11. .../

Theorem 3.12 was first proved by P. ERDŐS :

P. ERDŐS - On the distribution function of additive functions  
Ann. of Math. 47 (1946) p. 1-20

then generalized in :

P. ERDŐS - On the distribution of additive arithmetical functions and on some related problems  
Rend. Sem. Mat. Fis. Milano 27 (1957) p.45-49

Other proofs appeared in the literature. Amongst those, we mention :

A. MATÉ - A new proof of a theorem of P. ERDŐS  
Proc. Amer. Math. Soc. 18 (1967) p. 159-162

I. KÁTAI - A remark on additive arithmetical functions  
Amer. Univ. Sc. Budapest  
Eötvös Sect. Math. 10 (1967) p. 81-83

and the one we followed after J. ACZÉL and Z. DARÓCZY (see the book already quoted)

Additive functions in number theory have originated a large number of papers. For an account of what is known, we refer to various papers of H. DELANGE in the "séminaire de mathématiques de la Faculté d'Orsay" (France) in number theory.

Another proof of Erdős's result will be given in Chapter IV § 7.

Chapter IV

Theorems 4.1 and 4.2 are generalizations in various ways of the now classical Hahn-Banach theorem, which is central in functional analysis. We refer for a proof of the usual Hahn-Banach theorem itself to :

W. RUDIN - Real and complex analysis  
McGraw Hill 1966, 2nd ed. 1972 (French translation, Masson 1975).

or to :

G. CHOQUET - Lectures in Analysis, Vol I, II and III - Marsden Ed.  
Benjamin 1967

Theorems 4.1 and 4.2, or similar theorems, certainly appeared many times, notably in papers dealing with non-archimedean analysis. The idea of a use of such theorems for proving converse theorems in Cauchy equations goes back to a nice paper of :

Marcin E. KUCZMA - On discontinuous additive functions  
Fund. Math. 66 (1970) p. 383-392

Theorems 4.3. and 4.4 appeared in :

J. DHOMBRES, R. GER - Conditional Cauchy Equations  
Glasnik Mat. (1978) Vol 13 (33) p. 39-62

.../

and Theorem 4.5 appeared in :

J. DHOMBRES - Sur quelques extensions d'homomorphismes  
Comptes Rendus Acad.Sc. 281 (1975) p. 503-506

Such theorems generalize a certain number of results scattered in the literature. We quote some papers and refer to the bibliography of :

M. KUCZMA - Functional equations on restricted domains  
Aeq. Math (1978) 18 p. 1-34

for a more complete list of papers. Theorem 4.1 is classical in group theory.

Corollary 4.4. was first proved in :

Z. DARÓCZY - Über die Erweiterung der auf einer Punktmenge  
additiven Funktionen  
L. LOSONCZI  
Publ. Math. Debrecen 14 (1967) p. 239-245

The case of a non-connected open subset of  $\mathbb{R}^2$  has been treated in hungarian by Székelyhidi (cf. bibliography of M. KUCZMA).

A very special case of Theorem 4.5 (on  $\mathbb{R}$ , with  $X = [a, b]$  and  $f$  continuous) appeared in :

S. GOŁĄB, L. LOSONCZI - Über die Funktionalgleichung der Funktion  
Arccosinus I Die Lokalen Lösungen  
Publ. Math. Debrecen 12 (1965) p. 159-174

A special case of Theorem 4.3 with  $G = F = \mathbb{R}$  and  $X = [0, \infty[$  appeared in :

J. ACZÉL, P. ERDŐS - The non existence of a Hamel basis and the general solution  
of Cauchy's functional equation for non negative numbers  
Publ. Math. Debrecen 12 (1965) p. 259-265

In the setting of vector spaces over a commutative field, and for positively homogeneous function, Theorem 4.3 was investigated in :

M. KUCZMA - Some remarks about additive functions on cones  
Aeq. Math. 4 (1970) p. 303-306

Theorem 4.3 with  $X$  generating  $G$ , but also in some very special cases of non abelian groups appeared in :

J. ACZÉL, J.A. BAKER - Extensions of certain homomorphisms of semi-groups to  
D.Ž. ĐJOKOVIĆ, homomorphisms of groups  
PL. KANNAPAN, F.RADÓ Aeq. Math. 6 (1971) p. 263-271

Hamel bases were invented long ago :

G. HAMEL - Eine Basis aller Zahlen und die unstetigen Lösungen der  
Funktionalgleichung  $f(x+y)=f(x)+f(y)$   
Math. Ann. 60 (1905) p. 459-462.

Such bases often provide nice counterexamples in functional equations. For more about Lebesgue measures and Hamel bases, see :

P. ERDŐS - On some properties of Hamel bases  
Fund.Math. Vol X Fasc. 2 (1963)

.../

We have tried to exhibit strange behaviours of such bases. Another reference is :

J. ACZÉL, P. ERDŐS - The non existence of a Hamel basis and the general solution  
of Cauchy's functional equation for non negative numbers  
Publ. Math. Debrecen 12 (1965) p.259-265

Converse theorems for Cauchy solutions bounded somewhere both in  $\mathbb{R}$  or  $\mathbb{R}^n$  and some of the counterexamples are due to J. SMÍTAL in two papers:

J. SMÍTAL - On boundedness and discontinuity of additive functions  
Fund. Math. 76 (1972) p. 245-253

and,

J. SMÍTAL - A necessary and sufficient condition for continuity of  
additive functions  
Czeck Math. J. (1976) Vol 26 p. 171-173

The theorems given here are slightly modified versions.

Propositions 4.4 and 4.5 are in the already quoted paper of Marcin E. KUCZMA.

Other relevant references (mainly counterexamples) are to be found in two papers :

R. GER, M. KUCZMA - On the boundedness and continuity of convex functions and  
additive functions  
Aeq. Math. (1970) Vol 4 p. 157-162

R. GER - Some remarks on convex functions  
Fund. Math (1970) Vol 66 p. 255-262

Jensen convex functions have a long history. First their introduction in :

J.L.W.V. JENSEN - Sur les fonctions convexes et les inégalités entre les  
valeurs moyennes  
Acta Math. 30 (1906) p. 175-193

Then Proposition 4.7 with an open subset of  $\mathbb{R}$  :

F. BERNSTEIN - Zur Theorie der konvexen Funktionen  
G. DOETSCH Math. Annalen 76 (1915) p. 514-526

Then proposition 4.7 in  $\mathbb{R}$  :

A. OSTROWSKI - Zur Theorie der konvexen Funktionen  
Comm. Math. Helv. 1 (1929) p. 157-159

That continuity of Jensen functions comes from measurability was proved independently by :

H. BLUMBERG - On convex functions  
Trans. Amer. Math. Soc. 20 (1919) p. 40-44

W. SIERPINSKI - Sur les fonctions convexes mesurables  
Fund. Math. 1 (1920) p. 125-129

Proposition 4.7 in  $\mathbb{R}^n$  came with :

E. MOHR - Beitrag zur Theorie der konvexen Funktionen  
Math. Nach. 8 (1952) p. 133-148

.../



Theorem 4.13 (i) in  $\mathbb{R}$ , but with 2E appeared in :

S. KUREPA - Convex functions  
Glasnik Mat. 11 (1956) p. 89-93

Theorem 4.13 (i) in  $\mathbb{R}$  appeared in :

S. MARCUS - Critère de majoration pour les fonctions sous additives  
convexes ou internes  
Comptes Rendus Acad. Sc. Paris (1957) p. 244, p. 2270-2272

Theorem 4.13 (i) in  $\mathbb{R}^m$ , and Theorem 4.12 (iii) appeared independently in :

S. MARCUS - Généralisation aux fonctions de plusieurs variables, des  
théorèmes de A. Ostrowski et de M. Hukuhara concernant les  
fonctions convexes (J).  
Journal Math. Soc. Jap. Vol 11 No. 3 (1959) p.171-173

and in :

A. CSASZAR - On convex sets and functions  
Mat. Lapok 9 (1958) p. 273-282

Theorem 4.13 (iii) appeared in the already quoted paper of S. Marcus and in :

M. KUCZMA - Note on convex functions  
Ann. Univ. Sc. Budapest 2 (1959) p. 25-26

Theorem 4.13 (ii) appeared in :

M.R. MEHDI - Some remarks on convex functions  
J. London Math. Soc. 39 (1964) p. 321-326

A Jensen convex function, defined on an open and bounded subset  $\mathcal{O}$  of  $\mathbb{R}^m$  and bounded below on a subset of positive Lebesgue measure, is bounded below on  $\mathcal{O}$  but not necessarily continuous. See for  $n = 1$  :

M. HUKUHARA - Sur la fonction convexe  
Proc. Jap. Acad. (1954) 30 p. 683-685

and for any  $n$  the already quoted paper from S. Marcus.

See also,

J. SMITAL - On convex functions bounded below  
Aeq. Math. 14 (1976) p. 345-350

Generalizations of Jensen convex functions appeared in :

E. DEAK - Über konvexe und interne Funktionen, sowie eine gemein.  
same Verallgemeinerung von beiden  
Ann. Univ. Sc. Budapest 5 (1962) p.109-154

and in :

V. KLEE - Solutions of a problem of E.M. WRIGHT on convex function  
Amer. Math. Monthly 63 (1956) p.106-107

See also for Th. 4.13 (ii) :

M. KUCZMA - Convex functions  
in Functional equations and inequalities  
Ed. Cremonese Roma 1971 p. 195-213

.../

The study of conditional Cauchy equations linked with additive functions in number theory was done by :

C. PISOT, J. SCHOENBERG Arithmetic problems concerning Cauchy's functional eq.  
111. J. Math. 8 (1964) p. 40-56

See also :

Z. DARÓCZY, K. GYÖRY - Die Cauchysche Funktionalgleichung über diskrete Mengen  
Publ. Math. Debrecen 13 (1966) p. 249-255

The material for Theorem 4.17 comes from :

K. SUNDARESAN - Orthogonality and non linear functionals on Banach spaces  
Proc. Amer. Math. Soc. Vol 34 no. 1 (1972) p. 187-190

See also for special Banach spaces :

L. DREWNOWSKI - On orthogonally additive functionals  
W. ORLICZ - Bull. Amer. Math Soc 16 (1968) p. 883-888

and,

K. SUNDARESAN - Additive functionals on Orlicz spaces  
Studia Math 32 (1969) p. 269-276

A related result is stated without proof in :

F. VAJZOVIC - Über ein Funktional H mit der Eigenschaft  
 $(x, y) = 0 \Rightarrow H(x+y) + H(x-y) = 2(H(x) + H(y))$   
Aeq. Math 1 (1968) p. 141

See also for less regularity assumptions :

S. GUDDER - A converse to Pythagora's theorem  
D. STRAWTHER - Amer. Math. Monthly 1977, p. 551-553

Chapter V

The first treatment of Mikusinski's equation (Th 5.1, 5.2 and 5.3) appeared in :

L. DUBIKAJTIS, C. FERENS On Mikusinski's functional equation  
R. GER, M. KUCZMA - Ann. Polon. Math. 28 (1973) p. 39-47

Soon thereafter, quite a number of papers dealt with various improvements. We mention the paper wherein Theorem 5.5. was proved :

K. BARON, R. GER - On Mikusinski-Pexider functional equation  
Coll. Math 28 (1973) p. 307-312

See also :

R. GER - On some functional equations with a restricted domain  
I Fund. Math. 89 (1975) p. 131-149  
II Fund. Math. to appear

The method used in those two papers is discussed in § 6 and see the bibliography for the end of the chapter.

For other generalizations of Mikusinski's equation, we have to quote :

P. KANNAPPAN - On a functional equation related to the Cauchy equation  
M. KUCZMA - Ann. Polon. Math. 30 (1974) p. 49-55

.../

where Theorem 5.5 and 5.8 were proved and :

R. GER - On an alternative functional equation  
Aeq. Math 15 (1977) p. 145-162

where Theorem 5.9 is proved and general solutions provided for the functional equation dealt with in Theorem 5.9 (G, abelian group; F, integral domain of characteristic zero).

Propositions 5.3 and 5.4 are proved in the already quoted paper of R. GER.

A generalization (Proposition 5.5) was given in :

Marek KUCZMA - On a theorem of Roman GER  
Prace Matematyczne VI (1975) p. 73-76 N. 87

Theorem 5.6 was announced :

P. FISCHER - Sur l'équivalence des équations fonctionnelles  
 $f(x+y)=f(x)+f(y)$  et  $(f(x+y))^2 = (f(x)+f(y))^2$   
Annales de la Fac.Sc. Toulouse (1968) p.71-73

but a corrected proof appeared in :

M. KUCZMA - On some alternative functional equations  
Aeq. Math 17 (1978) p. 182-198

For a generalization of Theorem 5.6 to other kinds of functional equations, outside the previous paper, see the following paper and its bibliography:

H. SWIATAK - On alternative functional equations  
Aeq. Math 15 (1977) p. 35-47

The dual equation of Mikusinski's was first considered in the already quoted paper :

J. DHOMBRES, R. GER - Conditional Cauchy Equations  
Glasnik Mat. Vol 13 (33) 1978 p. 39-62

Subsequent generalizations or related results appeared in :

R. GER - On a method of solving of conditional Cauchy equations  
Univ. Beograd Publ. Elektro. Fak. Ser. Mat. Fiz.  
No. 544-576 (1976) p. 159-165

In this paper, R. GER exhibits a nice method which may eventually lead to the general solution of type IV.2.

R. GER - On some functional equations with a restricted domain  
Bull. Acad. Polon. Sci. Sér. Sc. Math. Astro. Phys. 24  
(1976) 429-432

E. VINCZE - Übereine Klasse der alternativen Funktionalgleichungen  
Aeq. Math. 2 (1969) p. 364-365

R. GER, M. KUCZMA - On inverse additive functions  
Bull. Un. Mat. Ital. (4) 11 (1975) p. 490-495

Conditional Cauchy equations of type V were first asked as an open question by P. ERDÖS (p. 310 Coll. Math. 7 (1960) p. 311) with  $\mathcal{C}$  being the family of subsets of  $\mathbb{R}$  of Lebesgue measure zero.

.../

A partial solution was found by :

S. HARTMAN - A remark about Cauchy's equation  
Colloquium Math. 8 (1961) p. 77-79

Then the problem was solved independently by :

W.B. JURKAT - On Cauchy's functional equations  
Proc. Amer. Math. Soc. 16 (1965) p. 683-686

N.G. de BRUIJN - On almost additive functions  
Colloquium Math. 15 (1966) p. 59-63

and,

J.L. DENNY - Sufficient conditions for a family of probabilities to be exponential  
Proc. Nat. Acad. Sc. USA 57 (1967) p.1184-1187

De BRUIJN noticed that his proof can be generalized to the setting of proper linearly invariant ideals in abelian groups. This was generalized to arbitrary groups in:

R. GER - Note on almost additive functions.  
Aeq. Math.

Generalizations were provided in various papers due to R. GER and already quoted. See also:

J. TABOR - Solution of Cauchy's functional equation on a restricted domain  
Colloquium Math. (to appear)

Nice generalizations are also proved in:

St. PAGANONI-MARZEGALLI - Cauchy's equation on a restricted domain  
Bull. Uni. Mat. Ital. A(5) 14 (1977) no. 2 p. 398-408

Chapter VI

Theorem 6.1 appeared without proof in :

J. DHOMBRES - Applications associatives ou commutatives  
Comptes rendus Acad. Sc. Paris t.281 (1975) p.809-812

Linear iteration of order two was discussed in groups in :

J. DHOMBRES - Itération linéaire d'ordre deux  
Comptes rendus Acad. Sc. Paris t. 280 (1975)

and in :

J. DHOMBRES - Itération linéaire d'ordre deux  
Publ. Math. Debrecen 24 (1977) p. 277-287

(a special bibliography is given there for Euler's functional equation)

On  $\mathbb{R}$ , the general continuous solution of  $g(g(x)) = \alpha g(x) + \beta x + \gamma$  is given in :

S. NABEYA - On the functional equation  $f(p+qx+rf(x)) = a+bx+cf(x)$   
Aeq. Math. 11 (1974) p. 199-211

The functional equation of linear iteration of order two is a special case of functional equations, on  $\mathbb{R}$ , treated by :

D. BRYDAK - Sur une équation fonctionnelle  
I Ann. Pol. Math. 15 (1964) p. 237-251  
II Ann. Pol. Math. 21 (1968) p. 1-13

Theorem 6.5 is proved in :

P. VOLKMANN - Eine Charakterisierung der positiv definiten quadratischen Formen  
Aeq. Math. Vol 11, 1974, p. 174-181

In this paper lemmata 6.3 and 6.1 are proved without the assumption  $\lim_{x \rightarrow \infty} g(x) = +\infty$

Theorem 6.5 was first proved by :

A.F. FICKEN - Notes on the existence of scalar products in normed linear spaces  
Annals of Math II Ser 45 (1944) p. 362-366

Theorem 6.6 was first proved amongst many other results in :

E.R. LORCH - On some implications which characterize Hilbert space  
Ann. of Math. 49 (1948) p. 523-532

See also :

N. ARONSZAJN - Caractérisation métrique de l'espace de Hilbert  
Comptes Rendus Acad. Sc. Paris 201 (1935)  
I p.811-813  
II p.873-875

In fact, Theorem 6.5 can be generalized with the same conclusion to the following situation :

For each  $x, y$  in  $E$  such that  $\|x\| = \|y\|$ , there exists a  $\delta, 0 < \delta < 1$ , and  $\|x+y\| = \|x+y\|$

.../

A proof using some sophisticated results about the geometry of convex subsets of  $\mathbb{R}^2$  can be found, with many other results in :

M.M. DAY - Normed spaces  
Springer Verlag 3rd ed. 1973

For § 4, the general solution of the functional equation dealt with in Th. 6.7, is to be found in two forms. The one given here appeared in :

P. JAVOR - On the general solution of the functional equations  
 $f(x+y)f(x) = f(x).f(y)$   
Aeq. Math. 1 (1968) p. 235-238

and another equivalent form appeared in :

S. WOŁODŹKO - Solution générale de l'équation fonctionnelle  
 $f(x+y)f(x) = f(x).f(y)$   
Aeq. Math. 2 (1968/69) p. 12-29

For regularity assumptions, see also :

P. JAVOR - Continuous solutions of the functional equation  
 $f(x+y)f(x) = f(x).f(y)$   
Proc. Int. Symp. on Topology and its applications Herceg-Novi 1968

For the occurrence of the functional equation in Theorem 6.7 for the research of subgroups of a centro-affine group, see :

S. GOŁĄB, A.SCHINZEL - Sur l'équation fonctionnelle  $f(x+y)f(x) = f(x).f(y)$   
Publ. Math. Debrecen 6, 113-125, (1959)

and,

J. ACZEL, S.GOŁĄB - Remarks on one parameter subsemigroups of the affine group and their homo and isomorphisms  
Aeq. Math. Vol 4 (1970) p.1-10

For its application to the theory of geometric objects, see :

J. ACZÉL - Beiträge zur Theorie der geometrische Objekte III, IV  
Acta Math. Acad. Sc. Hung 8 19-52 (1957)

For § 5, references up to 1976 are to be found, with the proofs of Theorems 6.8, 6.9 and of some related results for other functional equations, in :

J. DHOMBRES - Solution générale sur un groupe abélien de l'équation fonctionnelle  $f(x+f(y)) = f(x)*f(y)$ .  
Aeq. Math. 15 no. 2/3 (1977) p. 173-193

For a first treatment :

J. DHOMBRES - Functional equations on semi-groups arising from the theory of means  
Nanta Math. 5 (3) 1972 p. 48-66

For an introduction of the functional equations of § 5, from an harmonic analysis point of view, see :

J. DHOMBRES - Interpolation linéaire et équations fonctionnelles  
Ann. Polon. Math. 32 (3) 1975 p. 287-302

.../

and from an algebra point of view, see :

Y. MATRAS - Sur l'équation fonctionnelle  $f(x \cdot f(y)) = f(x) \cdot f(y)$   
Acad. Roy. Belg; Bull. Cl. Sc. 55(5) 1969 p. 731-751

More references for the multiplicative symmetry shall be given in Chapter VII.

The related equation :  $f(x+f(y)) = f(x)f(y)$  is the subject of :

C.F.K. JUNG - On the functional equation  $f(x+f(y)) = f(x)f(y)$   
Aeq. Math. 14 (1976) p. 41-48

V. BOONYASOMBAT  
G. BARBANÇON  
F.R. JUNG

For Eq(5) on  $\mathbb{R}$  with a continuity assumption, see :

Z. DARÓCZY - Über die Funktionalgleichung  $\Phi(\Phi(x)y) = \Phi(x)\Phi(y)$   
Acta Univ. Debrecen Ser. Fiz. Chem 8 (1962) p. 125-132

See also, for some generalizations,

F.R. JUNG, C.F.K. JUNG - Functional equations of Cauchy-Pexider-Jensen Type  
G. BARBANÇON Nanta Math. Vol 8 no. 1 p. 92-98

V. BOONYASOMBAT  
Related functional equations of the form  $f(x+f(y)) + f(y+f(x)) = \alpha(f(x)+f(y))$   
are treated in :

J. DHOMBRES - Itération linéaire d'ordre deux  
Publ. Math. Debrecen 24 (1977) p. 277-287

For the functional equation  $f(x * y) = f(f(x) * f(y))$  on semi-groups, see :

W. SCHWARZ, J. SPILKER - Über zahlentheoretische Funktionen, die  
 $f(x+y) = f(f(x)+f(y))$  erfüllen  
Mitt. Math. Sem. Giessen 111 (1974) p. 80-86

J.N. SIMONE - On number theoretic functions which satisfy  
 $f(x+y) = f(f(x)+f(y))$   
Math. Mag. 46 (1973) p. 213-215

J. DHOMBRES, J. SPILKER - Über die Funktionalgleichung  
 $f(f(x * f(y))) = f(x * f(y))$   
Manuscripta Math (1976) 18 p. 371-390

For corollary 6.7, see :

J. DHOMBRES - Associativity on the real axis  
Glasnik Mat. 11 (31) (1976) p. 37-40

Chapter VII

Reynolds operators have a long history. The first introduction was by:

O. REYNOLDS - On the dynamical theory of incompressible viscous fluids  
and the determination of the criterion  
Phil. Trans. of the Royal Soc. of London 186  
(1895) p. 123-164

An almost exhaustive list of references, before 1964, is to be found in a paper by:

G.C. ROTA - Reynolds operators  
Proc. Symp. Appl. Math. 16 (1964) p.70-83

For Reynolds operators over periodic functions and generalizations to almost periodic functions, see:

J.G. DHOMBRES - Some averaging process  
Kyungpook Math. J. 12, no. 2, (1972) p. 229-243

For both Reynolds,  $D(\alpha)$ , averaging operators and for multiplicatively symmetric operators in general, see:

J.G. DHOMBRES - Sur les opérateurs multiplicativement liés  
Mémoire de la Soc. Math. de France  
no. 27 (1971) 156 pages

For averaging operators on almost periodic functions, see:

J.G. DHOMBRES - Sur une classe de moyennes  
Annales de l'Institut Fourier 17 (1967) p. 135-156

For multiplicatively symmetric operators in the finite dimensional case, see:

J.G. DHOMBRES - Sur les opérateurs multiplicativement liés dans les algèbres  
de dimension finie  
Ann. Institut H. Poincaré Vol. 8, no. 4, 1972, p.333-363

Theorem 7.6 on derivation operator, appeared for the first time in:

I.M. SINGER, J.WERMER - Derivations on commutative normed algebras  
Math. Annalen 129 (1955) p. 260-264

The continuity assumption on the derivation operator was removed in:

B.E. JOHNSON - Continuity of derivations on commutative algebras  
Amer. J. Math. 91 (1969) p. 1-10

Theorem 7.6 was considerably generalized to some non abelian Banach algebras and it was proved that any derivation in a  $W^*$  algebra is inner. See a survey done in a chapter of:

S. SAKAI -  $C^*$  algebras and  $W^*$  algebras  
Springer Verlag 1971

We just mention that the techniques evolved into a cohomology theory for operator algebra. See:

B.E. JOHNSON - Cohomology in Banach algebras  
Memoirs of the Amer. Math. Soc. no. 127 (1972)

Outside the references already quoted for multiplicatively symmetric operators, we may mention links with interesting problems in functional analysis as explained in:

A. PEŁCZYŃSKI - Linear extensions, linear averaging, and their applications to linear topological classification of spaces of continuous functions  
Diss. Math. 58 (1968) 92 pp.

and,

J.G. DHOMBRES - Linear interpolation and linear extension of functions  
Proc. Int. Conf. in Functional Analysis  
Lecture Notes in Math. no. 399 Springer Verlag 1974

or,

J.G. DHOMBRES - Interpolation linéaire et équations fonctionnelles  
Ann. Polon. Math. 32 (3) 1975 p. 287-302

The equivalence between linear exaves according to A. Pełczyński and the multiplicatively symmetric operators was first proved in:

J.G. DHOMBRES - A functional characterization of markovian linear exaves  
Bull. Amer. Math. Soc. 81 no. 4 (1975) p. 703-706

Details appeared in:

J.G. DHOMBRES - 函数方程式, 平均算子, 插值算子和线性延拓算子。  
Nanta Math. vol IX no. 2, p. 109-116 (1976)

We already gave a reference for the functional equation of multiplicative symmetry in general (cf. reference for chapter VI, 5).

For the functional equations arising in the study of extreme points of subsets of operators, see references in the survey work of:

N. BRILLOUËT - Opérateurs extrémaux et sympathiques  
thèse de 3ème cycle  
Université de Nantes. France 1979

A first approach was done in:

R.M. BLUMENTHAL, - Extreme operators in  $C(K)$   
J. LINDENSTRAUSS, Pacif. J. Math. 15 (1966) 747-756  
R.R. PHELPS

The study was mainly developed by:

M. SHARIR - Extremal structures in operator spaces  
Trans. Amer. Math. Soc. 186 (1973) p. 91-111

and interesting counter-examples appeared in:

.../

M. SHARIR - A counter example in extreme operators  
Israel J. Math. 24 (1976) p.320-327

M. SHARIR - A non nice extreme operator  
Israel J. Math. 26 (1977) p.306-312

The study of extreme operators among doubly stochastic operators on a Lebesgue space is to be found in:

J.V. RYFF - Extreme points of some convex subsets of  $L^1 [0,1]$   
Proc. Amer. Math. Soc. 18 (1967) p. 1026-1034

and,

R.C. SHIFLETT - Extreme Markov operators and the orbits of Ryff  
Pacific J. Math. 40 (1972) p. 201-206

In the introduction of the special functional equation, see:

J.V. RYFF - The functional equation  $a f(ax) + b f(bx+a) = b f(bx) + a f(ax+b)$  extensions and almost periodic solutions  
Bull. Amer. Math. Soc. 82 (1976) p. 325-327

and an expanded version with proofs and consequences.

J.V. RYFF - The functional equation  $F(ax) + F(bx+a) = F(bx) + F(ax+b)$  Entire and almost periodic solutions.  
Publ. Dept. of Math. University of Connecticut  
Storrs (1977) 36 p.

Theorem 7.9 was proved in:

J.G. DHOMBRES - Some aspects of functional equations  
Lee Kong Chian Institute of Math.  
Nan Yang University  
Research Report no. 26 (1976) 28 p.