



HAL
open science

Model predictive control for discrete event systems with partial synchronization

Xavier David-Henriet, Laurent Hardouin, Jörg Raisch, Bertrand Cottenceau

► **To cite this version:**

Xavier David-Henriet, Laurent Hardouin, Jörg Raisch, Bertrand Cottenceau. Model predictive control for discrete event systems with partial synchronization. *Automatica*, 2016, 70, pp.9-13. 10.1016/j.automatica.2015.12.006 . hal-01307478

HAL Id: hal-01307478

<https://hal.science/hal-01307478>

Submitted on 26 Apr 2016

HAL is a multi-disciplinary open access archive for the deposit and dissemination of scientific research documents, whether they are published or not. The documents may come from teaching and research institutions in France or abroad, or from public or private research centers.

L'archive ouverte pluridisciplinaire **HAL**, est destinée au dépôt et à la diffusion de documents scientifiques de niveau recherche, publiés ou non, émanant des établissements d'enseignement et de recherche français ou étrangers, des laboratoires publics ou privés.

Model Predictive Control for Discrete Event Systems with Partial Synchronization

Xavier David-Henriet ^{a,b,c}, Laurent Hardouin ^b, Jörg Raisch ^{a,c},
Bertrand Cottenceau ^b

^a *Technische Universität Berlin, Fachgebiet Regelungssysteme, 10587 Berlin, Germany*

^b *Laboratoire Angevin de Recherche en Ingénierie des Systèmes, LARIS, ISTIA,
Université d'Angers, Angers 49000, France*

^c *Max-Planck-Institut für Dynamik komplexer technischer Systeme,
Fachgruppe System- und Regelungstheorie, 39106 Magdeburg, Germany*

Abstract

In this paper, we consider discrete event systems divided in a main system and a secondary system such that the inner dynamics of each system is ruled by standard synchronizations and the interactions between both systems are expressed by partial synchronizations (*i.e.*, event e_2 can only occur *when*, not after, event e_1 occurs) of events in the secondary system by events in the main system. The main contribution consists in adapting model predictive control, developed in the literature for $(\max, +)$ -linear systems, to the considered class of systems. This problem is solved under the condition that the performance of the main system is never degraded to improve the performance of the secondary system. Then, the optimal input is selected to respect the output reference and the remaining degrees of freedom are used to ensure just-in-time behavior. The unconstrained problem is solved in linear time with respect to the length of the prediction horizon.

Key words: Discrete event systems, synchronization, model-based control, predictive control, transportation control, timed Petri nets

1 Introduction

A discrete event system is a dynamical system driven by the instantaneous occurrence of events. In the following, we focus on a particular class of time-driven (*i.e.*, the occurrence of events is only possible at clock ticks) discrete event systems, the dynamics of which is defined by synchronization rules. The standard synchronization corresponds to the following condition: occurrence k of event e_1 is *at least* τ units of time after occurrence $k-l$ of event e_2 . Discrete event systems ruled only by standard synchronizations, called $(\max, +)$ -linear systems, have been widely studied and admit linear state-space representations in suitable algebraic structures such as the $(\max, +)$ -algebra and the $(\min, +)$ -algebra [8]. During

the last two decades, a rich control theory has been developed for this class of systems (*e.g.*, optimal feedforward control [2], model predictive control (MPC) [6,9], and model reference control [3]). Other synchronization rules have recently been investigated such as soft synchronization [7] and partial synchronization [4] (*i.e.*, event e_2 can only occur *when* event e_1 occurs). Partial synchronization is useful when a system A is offering a service for a time window to another system B . For example, in a public transportation network, a passenger can access a train only *when* the train is at the train station or a car can cross an intersection only *when*, not after, the traffic light is green. In this paper, we assume that the inner dynamics of systems A and B are driven by standard synchronizations and that system A is not affected by system B . Then, the complete system is divided in a main system and a secondary system (with disjoint event sets) such that the interactions between both systems are expressed by partial synchronizations of events in the secondary system by events in the main system. We focus on the control of this kind of systems under the assumption that the performance of the main

Email addresses:

xavier.david-henriet@control.tu-berlin.de (Xavier David-Henriet), laurent.hardouin@univ-angers.fr (Laurent Hardouin), raisch@control.tu-berlin.de (Jörg Raisch), bertrand.cottenceau@univ-angers.fr (Bertrand Cottenceau).

system is never degraded to improve the performance of the secondary system. This makes sense in many applications, where the main system is not only used by the secondary system, but shared by many users. For example, a train (main system) does not wait for delayed passengers (secondary system). We consider MPC, initially introduced for $(\max, +)$ -linear systems in [6]. The unconstrained case is investigated in $(\min, +)$ -algebra, which is more suitable to deal with partial synchronizations than $(\max, +)$ -algebra [5]. We prove that the unconstrained MPC optimization problem is solved at each step with a complexity linear with the length of the prediction horizon.

Necessary mathematical tools are recalled in § 2. In § 3, the modeling is addressed and the behavior under the earliest functioning rule is investigated. In § 4, the main contribution of this paper, namely MPC, is introduced. Finally, the proposed control approach is applied to a supply chain in § 5.

2 Mathematical Preliminaries

The $(\min, +)$ -algebra, denoted $\overline{\mathbb{N}}_{min}$, is defined as the set $\mathbb{N}_0 \cup \{+\infty\}$ endowed with \min , denoted \oplus , and $+$, denoted \otimes . Formally, $\overline{\mathbb{N}}_{min}$ is a dioid [1]. As in standard algebra, the product \otimes is often denoted by juxtaposition (*i.e.*, ab corresponds to $a \otimes b$). The operation \oplus induces an order relation \preceq on $\overline{\mathbb{N}}_{min}$ defined as

$$\forall a, b \in \overline{\mathbb{N}}_{min}, \quad a \oplus b = b \Leftrightarrow a \preceq b$$

Obviously, \preceq corresponds to the dual of the standard order \leq in \mathbb{N}_0 (*i.e.*, $a \succeq b \Leftrightarrow a \leq b$). In the following, only the order relation \preceq is used for expressions related to $\overline{\mathbb{N}}_{min}$. Two particular elements in $\overline{\mathbb{N}}_{min}$ are the zero element (*i.e.*, the neutral element of \oplus), equal to $+\infty$ and denoted ε , and the unit element (*i.e.*, the neutral element of \otimes), equal to 0 and denoted e . By analogy with standard linear algebra, \oplus and \otimes are defined for matrices with entries in $\overline{\mathbb{N}}_{min}$. For $A, B \in \overline{\mathbb{N}}_{min}^{n \times m}$ and $C \in \overline{\mathbb{N}}_{min}^{m \times p}$,

$$(A \oplus B)_{ij} = A_{ij} \oplus B_{ij} \text{ and } (A \otimes C)_{ij} = \bigoplus_{k=1}^m A_{ik} C_{kj}$$

The sum \oplus and the product \otimes are order-preserving. Two additional operations on $\overline{\mathbb{N}}_{min}$ are \wedge , corresponding to the \max in standard algebra, and \backslash , where $a \backslash b$ denotes the greatest solution of $a \otimes x \preceq b$. An extension of these operations to the matrix case is straightforward.

3 Input-Output Behavior

To capture the behavior of discrete event systems, a counter f is associated with the eponymous event f to

count its occurrences. Formally, the counter f is a mapping from \mathbb{Z} to $\overline{\mathbb{N}}_{min}$, where $f(t)$ is defined as the number of occurrences of event f before or at time t . Interesting properties of counter f are

$$f(t) = e \text{ for } t < 0 \text{ and } t_1 \leq t_2 \Rightarrow f(t_1) \succeq f(t_2)$$

An advantage of the counter representation is its ability to easily express standard synchronizations in $\overline{\mathbb{N}}_{min}$. For example, the standard synchronizations “occurrence k of event e_2 is *at least* τ_1 units of time after occurrence $k - l_1$ of event $e_{1,1}$ and *at least* τ_2 units of time after occurrence $k - l_2$ of event $e_{1,2}$ ” correspond to the following inequality in $\overline{\mathbb{N}}_{min}$:

$$\forall t \in \mathbb{Z}, \quad e_2(t) \succeq l_1 e_{1,1}(t - \tau_1) \oplus l_2 e_{1,2}(t - \tau_2)$$

Partial synchronization can also be expressed by a condition on counters. For example, “event e_2 can only occur *when*, not *after*, event e_1 occurs” is equivalent to “if event e_1 does not occur at time t , then event e_2 does not occur at time t ”. This corresponds to

$$\forall t \in \mathbb{Z}, \quad e_1(t) = e_1(t - 1) \Rightarrow e_2(t) = e_2(t - 1)$$

Next, the conditions induced by synchronizations on the dynamics of the main system and of the secondary system are formally described. For each system, the event set is partitioned into state, input, and output events as it is done for $(\max, +)$ -linear systems. The behavior of the main system must be a solution of

$$\begin{cases} x_1(t) \succeq A_{10}x_1(t) \oplus A_{11}x_1(t - 1) \oplus B_1u_1(t) \\ y_1(t) \succeq C_1x_1(t) \end{cases}$$

where x_1 , u_1 , and y_1 respectively denote the vectors of counters associated with state, input, and output events in the main system. The entries of matrices A_{10} , A_{11} , B_1 , and C_1 are given by the standard synchronizations in the main system. Due to partial synchronizations, the dynamics of the secondary system is slightly more complicated. The behavior of the secondary system must be a solution of

$$\begin{cases} x_2(t) \succeq A_{20}x_2(t) \oplus A_{21}x_2(t - 1) \oplus B_2u_2(t) \\ y_2(t) \succeq C_2x_2(t) \\ \forall i, (\exists x_{1,j} \in \mathcal{S}_i | x_{1,j}(t) = x_{1,j}(t - 1)) \\ \Rightarrow x_{2,i}(t) = x_{2,i}(t - 1) \end{cases}$$

where x_2 , u_2 , and y_2 respectively denote the vectors of counters associated with state, input, and output events in the secondary system. The entries of matrices A_{20} , A_{21} , B_2 , and C_2 are given by the standard synchronizations in the secondary system. The third condition expresses partial synchronizations: \mathcal{S}_i denotes the set

of state events in the main system synchronizing state event $x_{2,i}$ in the secondary system.

Remark 1 *By analogy with (max, +)-linear systems, we assume that matrices A_{10} and A_{20} are strictly lower triangular [1].*

Apart from the partial synchronization condition, the main and the secondary system are described by the same model structure. This allows us to treat both systems in a unified way as follows.

$$\begin{cases} x(t) \succeq A_0 x(t) \oplus A_1 x(t-1) \oplus Bu(t) \\ y(t) \succeq Cx(t) \\ \forall i, \quad \alpha_i(t) = 0 \Rightarrow x_i(t) = x_i(t-1) \end{cases} \quad (1)$$

where x , u , and y are vectors (with dimension n , p , and q) of counters associated with state, input, and output events. Mapping α_i is defined from \mathbb{Z} to $\{0, 1\}$ such that $\alpha_i(t) = 1$ if, and only if, partial synchronizations allow event x_i to occur at time t . For an event x_i of the main system, $\alpha_i(t) = 1$. For an event x_i of the secondary system,

$$\alpha_i(t) = \begin{cases} 0 & \text{if } \exists x_{1,j} \in \mathcal{S}_i | x_{1,j}(t) = x_{1,j}(t-1) \\ 1 & \text{otherwise} \end{cases} \quad (2)$$

Problem (1) only describes admissible behaviors. In the following, a standard behavior is introduced, namely the behavior under the earliest functioning rule (*i.e.*, each state or output event occurs as soon as possible). Hence, assuming that the behavior is known for times $\tau < t$, the behavior at time t is given by the least solution $(y(t), x(t))$ of (1) with the additional causality conditions $y(t) \preceq y(t-1)$ and $x(t) \preceq x(t-1)$. Checking existence and uniqueness of the behavior under the earliest functioning rule is not difficult and leads to the following input-output behavior:

$$\begin{cases} x(t) = H(x(t-1), u(t), t) \\ y(t) = Cx(t) \end{cases} \quad (3)$$

where

$$H(x(t-1), u(t), t)_i = \begin{cases} x_i(t-1) & \text{if } \alpha_i(t) = 0 \\ \bigoplus_{j=1}^{i-1} A_{0,ij} H(x(t-1), u(t), t)_j \\ \oplus (A_1 x(t-1) \oplus Bu(t))_i & \text{if } \alpha_i(t) = 1 \end{cases} \quad (4)$$

The previous discussion ensures the existence and uniqueness of the behavior under the earliest functioning rule for the considered systems and leads to an

algorithm to compute it. First, the behavior of the main system is obtained with $\alpha_i(t) = 1$. Then, the mappings α associated with the secondary system are given by (2). Finally, the behavior of the secondary system is computed.

4 Model Predictive Control

Model predictive control (MPC) for (max, +)-linear systems has been investigated in [6,9]. In the following, this approach is adapted to the considered class of systems. Let us briefly recall the principle of MPC. From time t to $t+1$, an optimal input is computed over a prediction horizon by minimizing a cost function using a prediction of the future behavior based on the model. At time $t+1$, this optimal input is applied to the system, the prediction horizon is shifted by one time step, and the computation is repeated using event occurrences at time $t+1$. The considered control approach gives priority to the main system over the secondary system: the performance of the main system is never degraded to improve the performance of the secondary system. This allows us to first compute optimal inputs for the main system. If a single optimal input for the main system exists, it remains to calculate the optimal input for the secondary system under a predefined behavior of the main system. The cost criterion used in the following leads to a single optimal input, which allows us to separate the complete problem in two subproblems.

In the following, a method to obtain the optimal input for a system described by (3) is presented. The optimal input is selected to minimize the expected delay with respect to an output reference. The remaining degrees of freedom in the choice of the optimal input are used to ensure the just-in-time behavior (*i.e.*, input events occur as late as possible). Notice that this approach suits transportation problems, as minimizing the expected delay corresponds to respecting the schedule as closely as possible and just-in-time behavior reduces the travel time. The cost function used to minimize the expected delay at time $t+1$ is

$$J_1(\tilde{y}) = \sum_{\tau=t+1}^{t+T} \sum_{j=1}^q \max(r_j(\tau) - \tilde{y}_j(\tau), 0)$$

where \tilde{y} is the predicted output, r is the output reference, and T is the length of the prediction horizon. This cost function is the equivalent for counters of the tardiness criterion introduced in [6] for daters. If $J_1(\tilde{y}) = 0$, the predicted output respects the output reference (*i.e.*, $\tilde{y}(\tau) \preceq r(\tau)$). The cost function used to ensure the just-in-time behavior at time $t+1$ is

$$J_2(\tilde{u}) = \sum_{\tau=t+1}^{t+T} \sum_{j=1}^p (\tilde{u}_j(\tau) - u_j(t))$$

If $J_2(\tilde{u}) = 0$, no input events occur over the prediction horizon. The optimization problem to solve between time t and time $t + 1$ is

$$\begin{aligned} & \underset{\tilde{u}(t+1), \dots, \tilde{u}(t+T)}{\text{minimize}}_{\mathcal{L}} (J_1(\tilde{y}), J_2(\tilde{u})) \\ & \text{subject to} \\ & \begin{cases} \tilde{x}(\tau) = H(\tilde{x}(\tau-1), \tilde{u}(\tau), \tau) \\ \tilde{y}(\tau) = C\tilde{x}(\tau) \\ \tilde{u}(\tau) \preceq \tilde{u}(\tau-1) \end{cases} \quad (5) \\ & \text{for } t+1 \leq \tau \leq t+T \\ & \tilde{u}(t) = u(t) \text{ and } \tilde{x}(t) = x(t) \end{aligned}$$

The subscript \mathcal{L} means that the considered order relation for the cost function with values in \mathbb{R}^2 is the lexicographic order relation. Before solving (5), an intermediate lemma is introduced.

Lemma 2 *The inequality $x(t) = H(x(t-1), u(t), t) \preceq z(t)$ admits a greatest solution $(x(t-1), u(t))$, denoted $(F(z(t), t), G(z(t), t))$.*

PROOF. Let us denote $\mathcal{K} = \{j | \alpha_j(t) = 1\}$ and $\mathcal{K}_i = \{j | j > i \text{ and } \alpha_j(t) = 1\}$. Then, according to (4), the least upper bound $\zeta(t)$ of $x(t)$ is given by

$$\zeta_i(t) = z_i(t) \wedge \bigwedge_{j \in \mathcal{K}_i} A_{0,ji} \zeta_j(t)$$

Based on $\zeta(t)$, the greatest solution $(F(z(t), t), G(z(t), t))$ is computed using (4). This leads to

$$\begin{aligned} F(z(t), t)_i &= \begin{cases} \zeta_i(t) \wedge \bigwedge_{j \in \mathcal{K}} A_{1,ji} \zeta_j(t) & \text{if } \alpha_i(t) = 0 \\ \bigwedge_{j \in \mathcal{K}} A_{1,ji} \zeta_j(t) & \text{if } \alpha_i(t) = 1 \end{cases} \\ G(z(t), t)_i &= \bigwedge_{j \in \mathcal{K}} B_{ji} \zeta_j(t) \quad \square \end{aligned}$$

Based on Lem. 2, a solution of (5) is obtained in the following theorem when the output reference r takes values in \mathbb{N}_0 over the prediction horizon (i.e., $r_j(\tau) \neq \varepsilon$ for $t+1 \leq \tau \leq t+T$). In practice, this is not restrictive, as the number of event occurrences remains bounded.

Theorem 3 *Denote \tilde{y}_ε the output induced by the input \tilde{u}_ε , defined by $\tilde{u}_\varepsilon(\tau) = \varepsilon$ for $t+1 \leq \tau \leq t+T$ and assume that $r_j(\tau) \in \mathbb{N}_0$ for $t+1 \leq \tau \leq t+T$. Then, the unique solution of (5), denoted \tilde{u}_{opt} , is given by*

$$\tilde{u}_{opt}(\tau) = \bigwedge_{\tau \geq j \geq t} \tilde{v}(j) \text{ for } t+1 \leq \tau \leq t+T$$

where $\tilde{v}(t) = u(t)$ and the sequence $(\tilde{v}(\tau))_{t+1 \leq \tau \leq t+T}$ is defined by

$$\begin{aligned} & \zeta(t+T) = \tilde{z}(t+T) \\ & \begin{cases} \tilde{v}(\tau) = G(\zeta(\tau), \tau) \\ \zeta(\tau-1) = F(\zeta(\tau), \tau) \wedge \tilde{z}(\tau-1) \end{cases} \quad (6) \end{aligned}$$

where $\tilde{z}(\tau) = C \zeta(\tau) \oplus \tilde{y}_\varepsilon(\tau)$ for $t+1 \leq \tau \leq t+T$.

PROOF. The following optimization problem is first considered.

$$\begin{aligned} & \underset{\tilde{u}(t+1), \dots, \tilde{u}(t+T)}{\text{minimize}} J_1(\tilde{y}) \\ & \text{subject to} \\ & \begin{cases} \tilde{x}(\tau) = H(\tilde{x}(\tau-1), \tilde{u}(\tau), \tau) \\ \tilde{y}(\tau) = C\tilde{x}(\tau) \\ \tilde{u}(\tau) \preceq \tilde{u}(\tau-1) \end{cases} \quad (7) \\ & \text{for } t+1 \leq \tau \leq t+T \\ & \tilde{u}(t) = u(t) \text{ and } \tilde{x}(t) = x(t) \end{aligned}$$

The cost function J_1 is order-preserving: $\tilde{y}_1 \succeq \tilde{y}_2$ implies $J_1(\tilde{y}_1) \geq J_1(\tilde{y}_2)$. Therefore, to solve (7), it is sufficient to find the least predicted output \tilde{y} , if it exists. As the product \otimes is order-preserving, it is sufficient to obtain the least predicted state \tilde{x} , if it exists. As the mapping H is order-preserving with respect to the first two arguments, it is sufficient to find the least future input \tilde{u} , which exists and is equal to \tilde{u}_ε . Hence, the optimal cost for (7) is $J_1(\tilde{y}_\varepsilon)$, where \tilde{y}_ε is the output induced by \tilde{u}_ε . As a lexicographic order relation is considered in (5), solving (5) is equivalent to solving the following optimization problem.

$$\begin{aligned} & \underset{\tilde{u}(t+1), \dots, \tilde{u}(t+T)}{\text{minimize}} J_2(\tilde{u}) \\ & \text{subject to} \\ & \begin{cases} \tilde{x}(\tau) = H(\tilde{x}(\tau-1), \tilde{u}(\tau), \tau) \\ \tilde{y}(\tau) = C\tilde{x}(\tau) \\ \tilde{u}(\tau) \preceq \tilde{u}(\tau-1) \end{cases} \quad (8) \\ & \text{for } t+1 \leq \tau \leq t+T \\ & J_1(\tilde{y}) = J_1(\tilde{y}_\varepsilon) \\ & \tilde{u}(t) = u(t) \text{ and } \tilde{x}(t) = x(t) \end{aligned}$$

Next, we show that $J_1(\tilde{y}) = J_1(\tilde{y}_\varepsilon)$ is equivalent to $\tilde{y}(\tau) \preceq r(\tau) \oplus \tilde{y}_\varepsilon(\tau)$ for $t+1 \leq \tau \leq t+T$. As $J_1(\tilde{y}) \geq J_1(\tilde{y}_\varepsilon)$ and $J_1(\tilde{y}_\varepsilon)$ is finite, $J_1(\tilde{y}) = J_1(\tilde{y}_\varepsilon)$ is equivalent to

$$\max(r_j(\tau) - \tilde{y}_j(\tau), 0) = \max(r_j(\tau) - \tilde{y}_{\varepsilon,j}(\tau), 0)$$

for all $1 \leq j \leq q$ and $t+1 \leq \tau \leq t+T$. If $\tilde{y}_{\varepsilon,j}(\tau) \geq r_j(\tau)$, $\max(r_j(\tau) - \tilde{y}_j(\tau), 0) = 0$. This leads to

$$\tilde{y}_j(\tau) \geq r_j(\tau) = \min(r_j(\tau), \tilde{y}_{\varepsilon,j}(\tau))$$

Otherwise, if $r_j(\tau) > \tilde{y}_{\varepsilon,j}(\tau)$, $\max(r_j(\tau) - \tilde{y}_j(\tau), 0) = r_j(\tau) - \tilde{y}_{\varepsilon,j}(\tau)$. This leads to $\tilde{y}_j(\tau) = \tilde{y}_{\varepsilon,j}(\tau)$ or, as $\tilde{y} \leq \tilde{y}_{\varepsilon}$, to

$$\tilde{y}_j(\tau) \geq \tilde{y}_{\varepsilon,j}(\tau) = \min(r_j(\tau), \tilde{y}_{\varepsilon,j}(\tau))$$

Replacing the constraint $J_1(\tilde{y}) = J_1(\tilde{y}_{\varepsilon})$ by an equivalent inequality over \tilde{x} allows us to transform (8) in

$$\begin{aligned} & \underset{\tilde{u}(t+1), \dots, \tilde{u}(t+T)}{\text{minimize}} && J_2(\tilde{u}) \\ & \text{subject to} && \\ & \begin{cases} \tilde{x}(\tau) = H(\tilde{x}(\tau-1), \tilde{u}(\tau), \tau) \\ \tilde{x}(\tau) \leq \tilde{z}(\tau) \\ \tilde{u}(\tau) \leq \tilde{u}(\tau-1) \end{cases} && (9) \\ & \text{for } t+1 \leq \tau \leq t+T \\ & \tilde{u}(t) = u(t) \text{ and } \tilde{x}(t) = x(t) \end{aligned}$$

where $\tilde{z}(\tau) = C \setminus (r(\tau) \oplus \tilde{y}_{\varepsilon}(\tau))$. As $\tilde{u}_1 \leq \tilde{u}_2$ implies $J_2(\tilde{u}_1) \geq J_2(\tilde{u}_2)$, solving (9) is equivalent to find the greatest (if it exists) input \tilde{u} satisfying the conditions in (9). For $t+1 \leq \tau \leq t+T$, $\tilde{u}(\tau) \leq \tilde{v}(\tau)$ where $(\tilde{v}(\tau))_{t+1 \leq \tau \leq t+T}$ is the greatest solution of

$$\begin{cases} \tilde{x}(\tau) = H(\tilde{x}(\tau-1), \tilde{v}(\tau), \tau) \\ \tilde{x}(\tau) \leq \tilde{z}(\tau) \end{cases} \text{ for } t+1 \leq \tau \leq t+T \text{ and } \tilde{x}(t) = x(t)$$

By analogy with optimal feedforward control for $(\max, +)$ -linear systems [2], $(\tilde{v}(\tau))_{t+1 \leq \tau \leq t+T}$ is given by (6). Therefore, the optimal input $(\tilde{u}_{opt}(\tau))_{t+1 \leq \tau \leq t+T}$ is the greatest decreasing sequence less than or equal to $(\tilde{v}(\tau))_{t+1 \leq \tau \leq t+T}$. Hence,

$$\tilde{u}_{opt}(\tau) = \bigwedge_{\tau \geq j \geq t} \tilde{v}(j) \text{ with } \tilde{v}(t) = u(t)$$

Further, as r takes value in \mathbb{N}_0 , $r(t+T)$ is finite. Hence, due to event-causality associated with standard synchronization, $\tilde{u}_{opt}(t+T)$ is finite. Then, \tilde{u}_{opt} is the unique optimal input, as, for finite inputs, $\tilde{u}_1 < \tilde{u}_2$ implies $J_2(\tilde{u}_2) < J_2(\tilde{u}_1)$. \square

Th. 3 provides an algorithm to implement MPC for a dynamic system described by (3). Further, the complexity of optimal input calculation at a given time t is linear with the length of the prediction horizon T , as the

calculations of \tilde{y}_{ε} , \tilde{v} , and \tilde{u}_{opt} come down to applying a forward or backward recursive relations over the prediction horizon. Finding the optimal input for the complete system (*i.e.*, main and secondary system) boils down to, first, compute the optimal input for the main system, second, predict the mappings α associated with the secondary system, and, finally, compute the optimal input for the secondary system. Therefore, the complexity of optimal input calculation at a given time t for the complete system remains linear with the length of the prediction horizon.

5 Example

The problem considered in this example focuses on a supply chain where intermodal containers shuttle back and forth between warehouses A_1 and B_1 . The supply chain is divided in three sections: a road transport section between warehouse A_1 and train station A , a rail transport section between train stations A and B , and a road transport section between train station B and warehouse B_1 . The supply chain is drawn in Fig. 1 (where the solid loop represents the train line, the dashed loops represent the road transport, and the dotted loop represents the supply chain). In road transport, the truck/container inter-

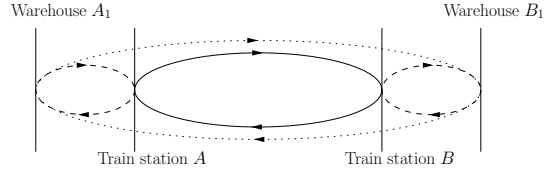

Fig. 1. The supply chain

action is neglected: sufficiently many trucks are available to deliver containers. The train/container interaction is expressed by partial synchronizations: a container leaves (resp. arrives at) a train station by train only *when* a train leaves (resp. arrives at) this train station. In this example, the main system corresponds to the train line and the secondary system models the transportation of the container. In Fig. 2, the overall system is represented by a timed Petri net where the dashed arrows correspond to the partial synchronizations. The proposed MPC con-

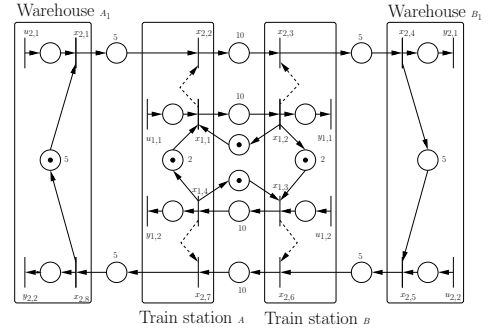

Fig. 2. Petri net representation

control approach is applied. As trains are shared by many users (including, but not limited to, the supply chain between warehouses A_1 and B_1), it makes sense to never degrade the performance of the train line to improve the performance of the supply chain between warehouses A_1 and B_1 . In this example, the considered cost functions (*i.e.*, tardiness and just-in-time criterion) are suitable to enforce delivery dates and minimize travel times. Furthermore, due to output reference update and optimal input recalculation at each time step, changes in the schedule and perturbations are taken into account.

In the following, MPC is applied to this system with a prediction horizon of length $T = 100$ and the following schedules:

- a train arrives in train stations A and B every 15 units of time with a first arrival at $t = 15$
- a container arrives in warehouse B_1 (resp. A_1) every 80 units of time with a first arrival at $t = 40$ (resp. $t = 80$)

This corresponds to the following output references:

$$r_{1,1}(t) = r_{1,2}(t) = \left\lfloor \frac{t}{15} \right\rfloor$$

$$r_{2,1}(t) = \left\lfloor \frac{t+40}{80} \right\rfloor \text{ and } r_{2,2}(t) = \left\lfloor \frac{t}{80} \right\rfloor$$

For the train line, the optimal input obtained with MPC is a departure from train stations A and B every 15 units of time with a first departure at $t = 5$. Formally,

$$u_{1,1}(t) = u_{1,2}(t) = \left\lfloor \frac{t+10}{15} \right\rfloor$$

For the supply chain, the optimal input obtained with MPC has a more complex pattern due to interactions with the train line:

$$u_{2,1}(t) = \left\lfloor \frac{t+225}{240} \right\rfloor + \left\lfloor \frac{t+150}{240} \right\rfloor + \left\lfloor \frac{t+60}{240} \right\rfloor$$

$$u_{2,2}(t) = \left\lfloor \frac{t+180}{240} \right\rfloor + \left\lfloor \frac{t+105}{240} \right\rfloor + \left\lfloor \frac{t+30}{240} \right\rfloor$$

Further, if a perturbation prevents the departure of train from train station A for $50 \leq t \leq 60$, the optimal input is modified as follows:

- the train line functions at a maximal throughput (*i.e.*, one train every 12 units of time) for $70 \leq t \leq 100$ to catch up the delay induced by the perturbation
- the first (resp. second) departure of the container from warehouse B_1 (resp. A_1) is delayed of 13 (resp. 15) units of time to adjust to changes in the behavior of the train line

As expected, the computation time of the optimal input at each step, experimentally observed with a Scilab implementation, is linear with the length of the prediction horizon, denoted T .

T	128	256	512
Computation time (in s)	0.36	0.72	1.42

6 Conclusion

In this paper, we consider a particular class of discrete event systems ruled by standard and partial synchronizations. Based on a $(\min, +)$ -model, MPC is adapted to this class of systems by giving priority to the performance of the main system. In each system, the optimality criterion focuses on minimizing the expected delay, but the remaining degrees of freedom are used to ensure just-in-time behavior. At each step, the computation of the optimal input is linear with the length of the prediction horizon. As future work, we want to include a standard update for the reference output at each step to take into account additional constraints on the behavior of the system.

References

- [1] F. Baccelli, G. Cohen, G. J. Olsder, and J.-P. Quadrat. *Synchronization and Linearity, An Algebra for Discrete Event Systems*. John Wiley and Sons, New York, USA, 1992.
- [2] G. Cohen, S. Gaubert, and J. P. Quadrat. From First to Second-Order Theory of Linear Discrete Event Systems. In *12th IFAC World Congress*, volume 1, pages 679–682, Sydney, Jul. 1993.
- [3] B. Cottenceau, L. Hardouin, J.-L. Boimond, and J.-L. Ferrier. Model Reference Control for Timed Event Graphs in Dioids. *Automatica*, 37(9):1451–1458, September 2001.
- [4] X. David-Henriet, L. Hardouin, J. Raisch, and B. Cottenceau. Optimal Control for Timed Event Graphs under Partial Synchronization. In *52nd IEEE Conference on Decision and Control, CDC'13*, pages 7609–7614, Firenze, Italy, December 2013.
- [5] X. David-Henriet, L. Hardouin, J. Raisch, and B. Cottenceau. Modeling and Control for Max-Plus Systems with Partial Synchronization. In *International Workshop on Discrete Event Systems, WODES'14*, Paris, France, May 2014.
- [6] B. De Schutter and T. J. J. van den Boom. Model Predictive Control for Max-Plus-Linear Discrete Event Systems. *Automatica*, 37(7):1049–1056, July 2001.
- [7] B. De Schutter and T. J. J. van den Boom. MPC for Discrete-Event Systems with Soft and Hard Synchronisation Constraints. *International Journal of Control*, 76(1):82–94, January 2003.
- [8] B. Heidergott, G. J. Olsder, and J. W. van der Woude. *Max Plus at work : modeling and analysis of synchronized systems : a course on Max-Plus algebra and its applications*. Princeton series in applied mathematics. Princeton University Press, Princeton (N.J.), 2006.
- [9] I. Necoara. *Model Predictive Control for Max-Plus-Linear and Piecewise Affine Systems*. PhD thesis, Delft University of Technology, 2006.