



**HAL**  
open science

# Rolling Contact Fatigue Life Evaluation Using Weibull Distribution

K. Semrád, J. Čerňan, K. Draganová

► **To cite this version:**

K. Semrád, J. Čerňan, K. Draganová. Rolling Contact Fatigue Life Evaluation Using Weibull Distribution. *Mechanics, Materials Science & Engineering Journal*, 2016, 10.13140/RG.2.1.3338.9849 . hal-01301823

**HAL Id: hal-01301823**

**<https://hal.science/hal-01301823v1>**

Submitted on 13 Apr 2016

**HAL** is a multi-disciplinary open access archive for the deposit and dissemination of scientific research documents, whether they are published or not. The documents may come from teaching and research institutions in France or abroad, or from public or private research centers.

L'archive ouverte pluridisciplinaire **HAL**, est destinée au dépôt et à la diffusion de documents scientifiques de niveau recherche, publiés ou non, émanant des établissements d'enseignement et de recherche français ou étrangers, des laboratoires publics ou privés.

## Rolling Contact Fatigue Life Evaluation Using Weibull Distribution

Semrád K.<sup>1, a</sup>, Čerňan J.<sup>1, b</sup>, Draganová K.<sup>1, c</sup>

1 – Department of Aviation Technical Studies, Technical University of Kosice, Faculty of Aeronautics, Slovakia

a – [karol.semrad@tuke.sk](mailto:karol.semrad@tuke.sk)

b – [jozef.cernan@tuke.sk](mailto:jozef.cernan@tuke.sk)

c – [katarina.draganova@tuke.sk](mailto:katarina.draganova@tuke.sk)



DOI 10.13140/RG.2.1.3338.9849

**Keywords:** MS Excel, Weibull Distribution, Contact Fatigue Damage, Rolling Contact Fatigue, AXMAT, RMAT, Survival Probability, Sintered Materials, Hertzian Contact Stresses, Finite Element Method – FEM.

**ABSTRACT.** Surfaces subjected to rolling and sliding contacts may suffer from contact fatigue. This text deals with solid mechanic aspects of contact fatigue including the description of experimental study on contact fatigue. This document describes the methodology used in MS Excel for evaluation of component survival probability by Weibull distribution in application for evaluation of contact fatigue survival probability.

**Introduction.** Contact stresses and deformations are those that have their origin in the mutual contact of objects, realized by tiny contact areas. Principles of the contact mechanics can be applied for example for calculation of contact stresses between teeth of gear sets, within roller bearings, between the wheel and a rail of rail vehicles, etc. When two solid bodies are brought into a contact, the deformation occurs at or very close to the areas of the true contact, so we have to consider that the stress is three-dimensional. The Hertzian contact stresses (pressures) have a local character and that is the reason why their values, together with the distance from the contact area, decrease rapidly. Stresses that occur, when solving contact tasks, cannot be considered as the linear function of loads, because with the change of the load power, dimensions of the contact area are also different [1].

In the reliability engineering, failure analysis and survival analysis many statistical methodologies are used. In the article measured data were analysed using the Weibull distribution that is a continuous probability distribution, the gradients of which directly inform us about the shape and scale parameters corresponding to the characteristic life and failure rate of the specimen. Methodology for the Weibull distribution calculation in the commonly used MS Excel environment is also described.

**Rolling Contact Fatigue.** Considering one surface moving over the other in a rolling motion, the rolling element produces subsurface stresses. The effect of cyclically repeated contact stresses on the surface layer of solid parts are becoming visible, after certain time of running, when local subsurface cracks propagates and defects, commonly called pits, are formed. The process of pitting effect creation is the function of contact stresses, mechanical properties of material, surface roughness, internal stress distribution in layers close to the surface, condition of material microstructure – homogeneity and level of pollution, fibres orientation and sliding direction, attributes of used grease, direction and size of rolling. The inevitable condition and the main cause of pitting creation is the cyclical change of contact stress and is based on the fact that there is a relationship (similar to Wöhler curve diagram shown in Fig. 1) between the contact stress change amplitude and the number of cycles until the damage [1].

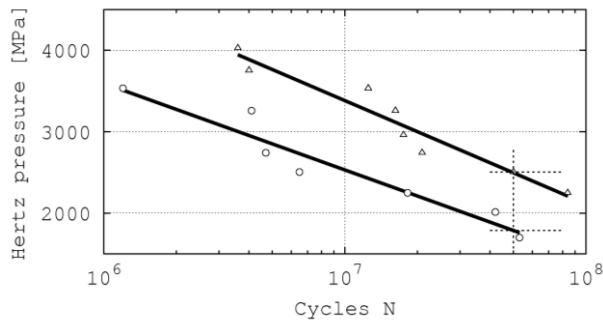

Fig. 1 Wöhler Curve Diagram

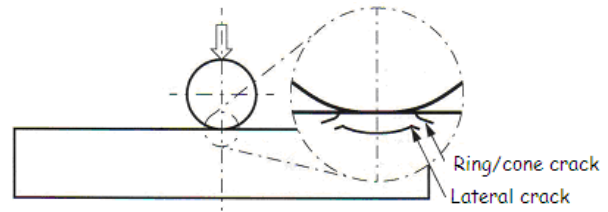

Fig. 2 Mechanism of Rolling Contact Fatigue

The whole process of the contact fatigue is the result of simultaneous effect of the rolling contact and material status. Considering enlarging and spreading of contact cracks, cracks have to form or already exist in the material structure (Fig. 2). In the first case, formation of micro-cracks mostly on two phases of boundary areas with considerable specific differences and acting like stress concentrators when loaded can be expected. Besides this, the high cyclic contact fatigue can evocate all by itself (in extreme testing conditions) phase transformations and so places with different structure and properties when compared to the main structure. In the second case, we are talking about a priori cracks, integrals or pores of a specific shape, which are able to grow immediately after loading (in certain conditions). Creation of the contact fatigue phenomenon does not occur in the whole specimen, only in the areas under the surface, where maximal shear stress is applied. However, the surface is sensitive, too, for example according to the strain energy hypothesis, the level of stress has the same value only if the friction factor reaches  $f=0,1$ . Of course, destruction can happen also by spreading of the fatigue cracks from the surface with existing defects, such as damaged surface, corrosion, low hardness or thick carbides [1].

**Experimental Equipments.** Equipment called AXMAT (Fig. 3 and 4) is designed for testing of flat circular specimen when verifying material resistance against the contact fatigue, to clarify the problem of rolling contact itself from material, tribological and lubrication point of view, between rolling parts. Maximal contact stress according to the point contact of the two - spheres theory, one with  $R_2=\infty$ , another  $R_1=R$ : contact of sphere and flat plane, is equals to:

$$\sigma_{\max} = 0,388,3 \sqrt[3]{4 F \frac{E_1^2 \cdot E_2^2}{(E_1 + E_2)^2} \cdot \frac{1}{R^2}} \quad (1)$$

where  $E_1, E_2$  are the Young's modules of contact parts materials and  $F$  is the loading power.

The dangerous place, from the strain point of view, is the point which lies on the connection of the spheres' centres and its distance from the contact plane is equal to the half of the contact area radius. Maximal shear stress equals to:

$$\tau_{\max} \cong 0,31 \cdot \sigma_{\max} \quad (2)$$

Flat, circular, ring-like shaped specimen with given dimensions is pressed by the rotating axial bearing ring, using standardized bearing balls which are situated between the specimen and the bearing [2].

The next testing equipment type RMAT gives us ability to try fatigue strength of materials under contact stress when rolling. Specimen of cylindrical shape with given dimensions is rolled by two rotating discs, also with given shapes, while one of discs also presses the specimen [2].

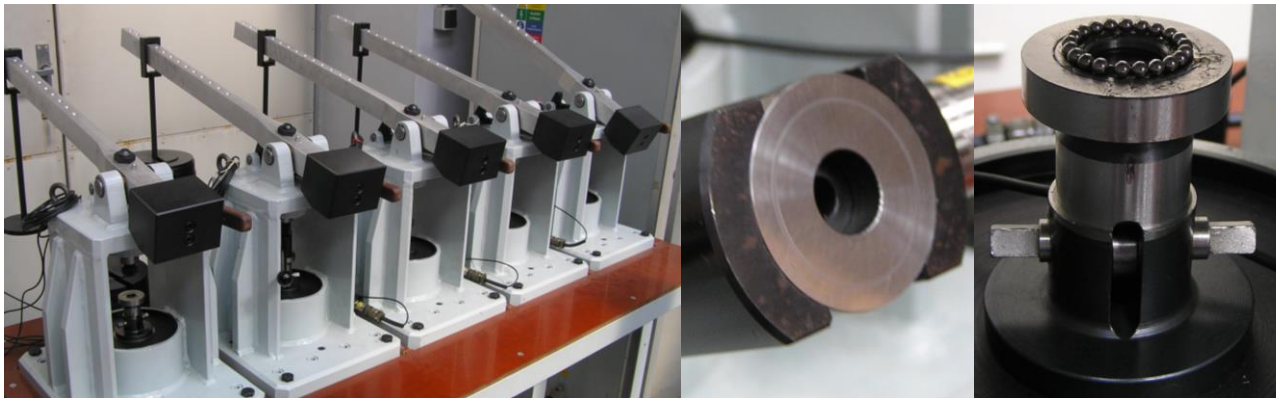

Fig. 3 AXMAT Experimental Equipment

**Data Evaluation.** In conditions of our department, AXMAT testing device was used to analyse formation of pitting damage at specimens made from sintered powders with adequate surface treatment, as part of the VEGA project No. 1/0464/08 - Tribological aspects of sintered materials damage with the emphasis on contact fatigue and wear out. Specimen provings run on using the testing device with chosen load level and are finished by pitting or by achieving 500 hours run out without break. Using this result, it is possible to create a relation between contact stresses and the number of cycles until pitting occurs (Fig. 1). In the specific case, the specimen was manufactured from sintered powder, alloyed 1,5Cr and 0,5Mo with the addition of 0,3C, die-pressed using 600 MPa pressure and temperature of 1120°C for the period of ½ hrs. The surface of the specimen was subsequently subjected to abrasion and plasma nitriding at the temperature of 520°C for the period of 7 hrs. For plotting the survival probability a set of 10 same material specimens are used. Time or the number of cycles until pitting damages appear under identical load conditions is recorded. In this case, the contact pressure is 1500 MPa. The results are evaluated by the Weibull distribution that shows the relation between the percentual survival probability and the number of cycles (Fig. 8). Using processed diagrams we are able to define L<sub>10</sub>, L<sub>50</sub>, L<sub>90</sub> levels for 10, 50 and 90 % survival probability value, respectively [2].

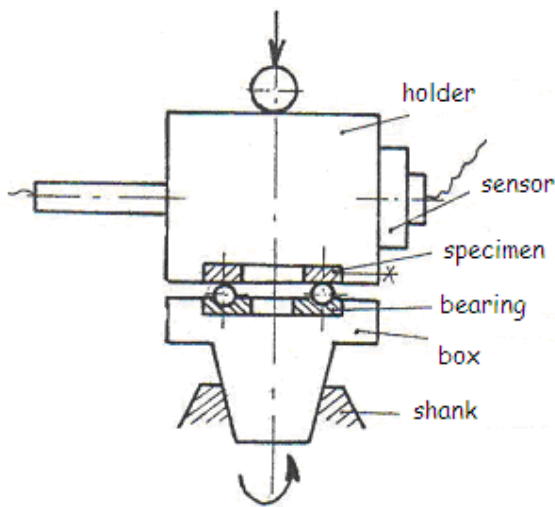

Fig. 4 AXMAT Design

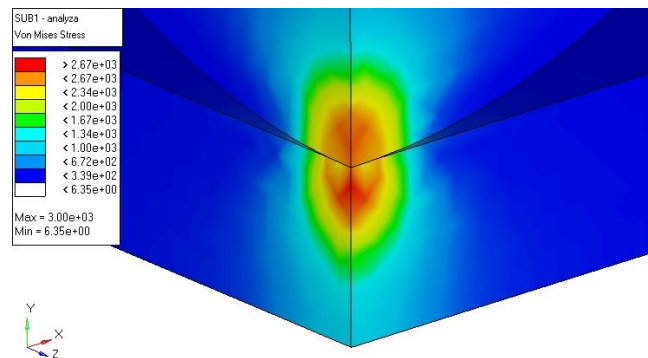

Fig. 5 FEM Analysis

As a control for calculate the maximum stresses by (1) and (2) we used the stress calculation using the finite element method (FEM). It gives a graphic picture of the stress distribution in the interesting area (Fig. 5).

	A	B	C	D	E	F
1	<b>Design Cycles</b>	<b>Rank</b>	<b>Median Ranks</b>	<b>1/(1-Median Rank)</b>	<b>ln(ln(1/(1-Median Rank)))</b>	<b>ln(Design Cycles)</b>
2	5 300 000	1	0.067307692	1.072164948	-2.663843085	15.48321738
3	5 828 000	2	0.163461538	1.195402299	-1.72326315	15.67818445
4	6 700 000	3	0.259615385	1.350649351	-1.202023115	15.71761808
5	10 000 000	4	0.355769231	1.552238806	-0.821666515	16.11809565
6	25 930 000	5	0.451923077	1.824561404	-0.508595394	17.07091116
7	38 319 000	6	0.548076923	2.212765957	-0.230365445	17.46145641
8	57 800 000	7	0.644230769	2.810810811	0.032924962	17.87249933
9	86 800 000	8	0.740384615	3.851851852	0.299032932	18.27911718
10	89 300 000	9	0.836538462	6.117647059	0.593977217	18.30751205
11	164 500 000	10	0.932692308	14.85714286	0.992688929	18.91842113
12						
13	<b>Coefficients</b>	<b>Beta/Alpha</b>				
14	0.826	0.826				
15	-14.631	49282275.97				
16						
17	<b>Cycles</b>	<b>Surv.Prob.</b>				
18	0	1.0000				
19	10 000 000	.7650				
20	20 000 000	.6220				
21	30 000 000	.5150				
22	40 000 000	.4310				
23	50 000 000	.3635				

Fig. 6 Preparing Data for Weibull Analysis in the MS Excel

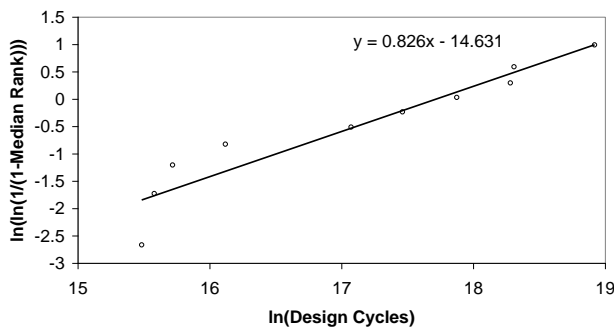

Fig. 7 Linear Fit Plot

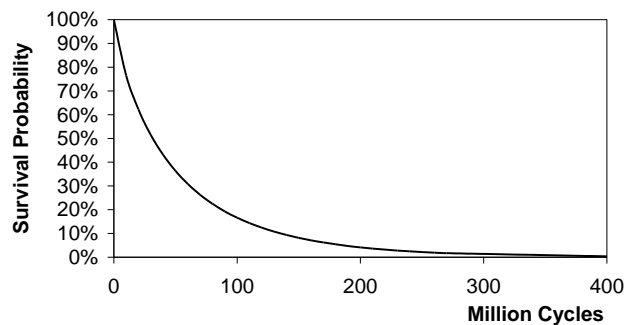

Fig. 8 Survival Graph

**Weibull analysis in MS Excel.** Modelling the data using Weibull analysis by MS Excel requires some preparation [3]. Open MS Excel and fill the cells (Fig. 6):

1. In cell A1 type the label Design Cycles. Enter the failure cycles data into cells A2:A11 from lowest to highest.
2. In cell B1 type the label Rank. In cells B2:B11 type the integers 1 – 10.
3. In cell C1 type the label Median Ranks. In cell C2 enter the formula:  $=((B2-0.3)/(10+0.4))$ . Next copy cell C2 down through cell C11. Note that in the formula for median ranks the 10 is the total number of design units tested.
4. In cell D1 type the label 1/(1-Median Rank). Then in D2 enter the formula:  $=1/(1-C2)$ . Copy cell D2 down through cell D11.
5. In cell E1 type the label ln(ln(1/(1-Median Rank))). In cell E2 type the formula:  $=LN(LN(D2))$ . Copy cell E2 down through cell E11.

6. In cell F1 type the label ln(Design Cycles). In cell F2 type the formula: =LN(A2). Copy cell F2 down through cell F11.

After the processed data visualisation (column E vs. column F) we can expect a straight line (Fig. 7). By performing a simple linear regression we can obtain parameters:  $\alpha$  - Characteristic Life, which is a measure of the scale, or spread, in the distribution of data and  $\beta$  - Shape Parameter, which indicates whether the failure rate is increasing. When the linear regression is performed, the estimate for the Weibull  $\beta$  parameter comes directly from the slope of the line. The estimate for the  $\alpha$  parameter has to be calculated as:

$$\alpha = e^{-\left(\frac{b}{\beta}\right)} \quad (3)$$

7. In cell A13 type the label Coefficients. Enter the coefficients from the linear regression formula:  $y=0,826x-14,631$  into cells A14, A15; where A15 is the  $b$  coefficient in formula (3). In this case  $b = -14,631$ .

8. In cell B13 type the label Beta/Alpha. In cell B14 enter the formula: =A14 and In cell B15 enter the formula: =EXP(-A15/A14).

The formula for reliability assuming a Weibull distribution is:

$$R(t) = e^{-\left(\frac{x}{\alpha}\right)^\beta} \quad (4)$$

where  $x$  is the time (or number of cycles) until failure.

9. In cell A17 type the label Cycles and In cells A18:A46 type the values 0 – 400 million in increments of 10 000 000.

10. In cell B17 type the label Survival Probability. In cell B18 type the formula: =1-WEIBULL(A18;B\$14;B\$15;TRUE). Copy cell B18 down through cell B46.

The result is the Survival Graph (Fig. 8). The data in column A(Cycles) vs. column B(Survival Probability) can be plotted in percentages [4].

**Summary.** The results of  $L_{10}$ ,  $L_{50}$ ,  $L_{90}$  levels for 10, 50 and 90 % survival probability value for our specimens made from sintered powders are:

$$L_{10} = 130\,000\,000 \text{ cycles}, L_{50} = 31\,000\,000 \text{ cycles}, L_{90} = 3\,000\,000 \text{ cycles}$$

Sintered materials with their specific structure (presence of pores) have different reaction on behaving in such conditions as presented. With respect to this fact and to reality of large boom in the sintered part production and their application in the automobile industry, there is an objective need for basic research and systematic monitoring of the attributes that do influence durability and life-time of such strained materials. The Weibull distribution's strength is in its versatility. Depending on the parameter's values, the Weibull distribution can approximate an exponential, normal or skewed distribution. The Weibull distribution's virtually limitless versatility is matched by Excel's countless capabilities.

## **References**

- [1] K. Semrad, V. Zahradnıček, Experimental Study on Contact Fatigue. In: Acta Avionica, vol. XI, no. 18, p. 97-100. Faculty of Aeronautics, Technical University of Kosice, 2009. ISSN 1335-9479.
- [2] K. Semrad, R. Zahradnıček, Using MS Excel for Evaluation of Component Survival Probability. In: ICMT'11: International Conference on Military Technologies 2011, Brno, Czech Republic, 10 to 11 May, 2011, p. 551-556. Faculty of Military Technology, University of Defence in Brno, 2011. ISBN 978-80-7231-788-2.
- [3] E. Ostertagova, Probability and Mathematical Statistics with examples (in Slovak). Elfa Košice, 2005, p. 123. ISBN 80-8086-005-X.
- [4] William W. Dorner, Using Microsoft Excel for Weibull Analysis. In: Quality Digest Magazine, January 1999, Best Access Systems, Indianapolis, USA, URL: [http://www.qualitydigest.com/jan99/html/body\\_weibull.html](http://www.qualitydigest.com/jan99/html/body_weibull.html)