



HAL
open science

2-Distance Colorings of Integer Distance Graphs

Brahim Benmedjdoub, Eric Sopena, Isma Bouchemakh

► **To cite this version:**

Brahim Benmedjdoub, Eric Sopena, Isma Bouchemakh. 2-Distance Colorings of Integer Distance Graphs. *Discussiones Mathematicae Graph Theory*, 2019, 39, pp.589-603. hal-01279943

HAL Id: hal-01279943

<https://hal.science/hal-01279943>

Submitted on 28 Feb 2016

HAL is a multi-disciplinary open access archive for the deposit and dissemination of scientific research documents, whether they are published or not. The documents may come from teaching and research institutions in France or abroad, or from public or private research centers.

L'archive ouverte pluridisciplinaire **HAL**, est destinée au dépôt et à la diffusion de documents scientifiques de niveau recherche, publiés ou non, émanant des établissements d'enseignement et de recherche français ou étrangers, des laboratoires publics ou privés.

2-Distance Colorings of Integer Distance Graphs

Brahim BENMEDJDOUB¹ Éric SOPENA^{2,3,4} Isma BOUCHEMAKH¹

February 28, 2016

Abstract

A 2-distance k -coloring of a graph G is a mapping from $V(G)$ to the set of colors $\{1, \dots, k\}$ such that every two vertices at distance at most 2 receive distinct colors. The 2-distance chromatic number $\chi_2(G)$ of G is then the smallest k for which G admits a 2-distance k -coloring. For any finite set of positive integers $D = \{d_1, \dots, d_k\}$, the integer distance graph $G = G(D)$ is the infinite graph defined by $V(G) = \mathbb{Z}$ and $uv \in E(G)$ if and only if $|v - u| \in D$. We study the 2-distance chromatic number of integer distance graphs for several types of sets D . In each case, we provide exact values or upper bounds on this parameter and characterize those graphs $G(D)$ with $\chi_2(G(D)) = \Delta(G(D)) + 1$.

Keywords: 2-distance coloring; Integer distance graph.

MSC 2010: 05C15, 05C12.

1 Introduction

All the graphs we consider in this paper are simple and loopless undirected graphs. We denote by $V(G)$ and $E(G)$ the set of vertices and the set of edges of a graph G , respectively. For any two vertices u and v of G , we denote by $d_G(u, v)$ the *distance* between u and v , that is the length of a shortest path joining u and v . We denote by $\Delta(G)$ the maximum degree of G .

A (proper) k -coloring of a graph G is a mapping from $V(G)$ to the set of colors $\{1, \dots, k\}$ such that every two adjacent vertices receive distinct colors. The smallest k for which G admits a k -coloring is the *chromatic number* of G , denoted $\chi(G)$. A *2-distance k -coloring* of a graph G is a mapping from $V(G)$ to the set of colors $\{1, \dots, k\}$ such that every two vertices at distance at most 2 receive distinct colors. 2-distance colorings are sometimes called *$L(1,1)$ -labelings* (see [5] for a survey on $L(h, k)$ -labelings) or *square colorings* in the literature. The smallest k for which G admits a 2-distance k -coloring is the *2-distance chromatic number* of G , denoted $\chi_2(G)$.

The *square* G^2 of a graph G is the graph defined by $V(G^2) = V(G)$ and $uv \in E(G^2)$ if and only if $d_G(u, v) \leq 2$. Clearly, a 2-distance coloring of a graph G is nothing but a proper coloring of G^2 and, therefore, $\chi_2(G) = \chi(G^2)$ for every graph G .

The study of 2-distance colorings was initiated by Kramer and Kramer [7] (see also their survey on general distance colorings in [8]). The case of planar graphs has attracted a lot of attention in the literature (see e.g. [1, 2, 3, 4, 6, 9, 12]), due to the conjecture of Wegner that suggests an upper bound on the 2-distance chromatic number of planar graphs depending on their maximum degree (see [13] for more details).

¹Faculty of Mathematics, Laboratory L'IFORCE, University of Sciences and Technology Houari Boumediene (USTHB), B.P. 32 El-Alia, Bab-Ezzouar, 16111 Algiers, Algeria.

²Univ. Bordeaux, LaBRI, UMR5800, F-33400 Talence, France.

³CNRS, LaBRI, UMR5800, F-33400 Talence, France.

⁴Corresponding author. Eric.Sopena@labri.fr.

In this paper, we study 2-distance colorings of distance graphs. Although several coloring problems have been considered for distance graphs (see [10] for a survey), it seems that 2-distance colorings have not been considered yet. We present in Section 2 a few basic results on the chromatic number of distance graphs. We then consider specific sets D , namely $D = \{1, a\}$, $a \geq 3$ (in Section 3), $D = \{1, a, a + 1\}$, $a \geq 3$ (in Section 4), and $D = \{1, \dots, m, a\}$, $2 \leq m < a$ (in Section 5). We finally propose some open problems in Section 6.

2 Preliminaries

Let $D = \{d_1, \dots, d_k\}$ be a finite set of positive integers. The *integer distance graph* (simply called *distance graph* in the following) $G = G(D)$ is the infinite graph defined by $V(G) = \mathbb{Z}$ and $uv \in E(G)$ if and only if $|v - u| \in D$.

If $\gcd(\{d_1, \dots, d_k\}) = p > 1$, the distance graph $G(D)$ has p connected components, each of them being isomorphic to the distance graph $G(D')$ with $D' = \{d_1/p, \dots, d_k/p\}$. In that case, we thus have $\chi_2(G(D)) = \chi_2(G(D'))$ so that we can always assume $\gcd(D) = 1$.

It is easy to observe that the square of the distance graph $G(D)$ is also a distance graph, namely the distance graph $G(D^2)$ where

$$D^2 = D \cup \{d + d' \mid d, d' \in D\} \cup \{d - d' \mid d, d' \in D, d > d'\}.$$

For instance, for $D = \{1, 2, 5\}$, we get $D^2 = \{1, 2, 3, 4, 5, 6, 7, 10\}$. Note that if D has cardinality k , then D^2 has cardinality at most $k(k + 1)$.

As observed in the previous section, $\chi_2(G) = \chi(G^2)$ for every graph G . Therefore, since $(G(D))^2 = G(D^2)$, determining the 2-distance chromatic number of the distance graph $G(D)$ reduces to determining the chromatic number of the distance graph $G(D^2)$. The problem of determining the chromatic number of distance graphs has been extensively studied in the literature. When $|D| \leq 2$, this question is easily solved, thanks to the following general upper bounds:

Proposition 1 (folklore) *For every finite set of positive integers $D = \{d_1, \dots, d_k\}$ and every positive integer p such that $d_i \not\equiv 0 \pmod{p}$ for every i , $1 \leq i \leq k$, $\chi(G(D)) \leq p$.*

Proof. Let $\lambda : V(G(D)) \rightarrow \{1, \dots, p\}$ be the mapping defined by

$$\lambda(x) = 1 + (x \pmod{p}),$$

for every integer $x \in \mathbb{Z}$. Since $d_i \not\equiv 0 \pmod{p}$ for every i , $1 \leq i \leq k$, the mapping λ is clearly a proper coloring of $G(D)$. \square

Theorem 2 (Walther [11]) *For every finite set of positive integers D ,*

$$\chi(G(D)) \leq |D| + 1.$$

Proof. A $(|D|+1)$ -coloring of $G(D)$ can easily be produced using the First-Fit greedy algorithm, starting from vertex 0, from left to right and then from right to left, since every vertex has exactly $|D|$ neighbors on its left and $|D|$ neighbors on its right. \square

Therefore, when $|D| \leq 2$, $\chi(G(D)) = 2$ if $|D| = 1$ or all elements in D are odd (since $G(D)$ is then bipartite), and $\chi(G(D)) = 3$ otherwise (since $G(D)$ then contains cycles of odd length). The case $|D| = 3$ has been settled by Zhu [14]. Whenever $|D| \geq 4$, only partial results have been obtained, namely for sets D having specific properties.

A coloring λ of a distance graph $G(D)$ is *p-periodic*, for some integer $p \geq 1$, if $\lambda(x+p) = \lambda(x)$ for every $x \in \mathbb{Z}$. Walther also proved the following:

Theorem 3 (Walther [11]) *For every finite set of positive integers D , if $\chi(G(D)) \leq k$ then $G(D)$ admits a p -periodic k -coloring for some p .*

The *pattern* of such a p -periodic coloring is defined as the sequence $\lambda(x) \dots \lambda(x+p-1)$. In particular, the coloring defined in the proof of Proposition 1 was p -periodic with pattern $12 \dots p$. In the following, we will describe such patterns using standard notation of Combinatorics on words. For instance, the pattern 121212345 will be denoted $(12)^3 345$.

Finally, note that in any 2-distance coloring of a graph G , all vertices in the closed neighborhood of any vertex must be assigned distinct colors. Therefore, we have the following:

Observation 4 *For every graph G , $\chi_2(G) \geq \Delta(G) + 1$.*

In particular, this bound is attained by the distance graph $G(D)$ with $D = \{1, \dots, k\}$, $k \geq 2$:

Proposition 5 *For every $k \geq 2$, $\chi_2(G(\{1, \dots, k\})) = 2k + 1 = \Delta(G(\{1, \dots, k\})) + 1$.*

Proof. It is easy to check that the mapping λ given by

$$\lambda(x) = 1 + (x \bmod 2k + 1)$$

for every $x \in \mathbb{Z}$ is a 2-distance $(2k + 1)$ -coloring of $G(\{1, \dots, k\})$. Equality then follows from Observation 4. \square

3 The case $D = \{1, a\}$, $a \geq 3$

We study in this section the 2-distance chromatic number of distance graphs $G(D)$ with $D = \{1, a\}$, $a \geq 3$ (note that the case $a = 2$ is already solved by Proposition 5).

When $D = \{1, a\}$, $a \geq 3$, we have $\Delta(G(D)) = 4$ and

$$D^2 = \{1, 2, a - 1, a, a + 1, 2a\}.$$

The following theorem gives the 2-distance chromatic number of any such graph:

Theorem 6 *For every integer $a \geq 3$,*

$$\chi_2(G(\{1, a\})) = \begin{cases} 5 & \text{if } a \equiv 2 \pmod{5}, \text{ or } a \equiv 3 \pmod{5}, \\ 6 & \text{otherwise.} \end{cases}$$

Proof. Since $\{1, a\}^2 = \{1, 2, a - 1, a, a + 1, 2a\}$, we get $d \not\equiv 0 \pmod{5}$ for every $d \in \{1, a\}^2$ whenever $a \equiv 2 \pmod{5}$ or $a \equiv 3 \pmod{5}$ and thus, by Proposition 1 and Observation 4, $\chi_2(G(\{1, a\})) = 5$.

Note that for every $x \in \mathbb{Z}$, the set of vertices

$$C(x) = \{x - a, x - 1, x, x + 1, x + a\}$$

induces a clique in $G(\{1, a\}^2)$ (see Figure 1). We now claim that every 2-distance 5-coloring λ of $G(\{1, a\})$ is necessarily 5-periodic, that is $\lambda(x + 5) = \lambda(x)$ for every $x \in \mathbb{Z}$. To show that, it suffices to prove that any five consecutive vertices $x, \dots, x + 4$ must be assigned distinct colors. Assume to the contrary that this is not the case and, without loss of generality, let $x = 0$. Since vertices 0, 1 and 2 necessarily get distinct colors, we only have two cases to consider:

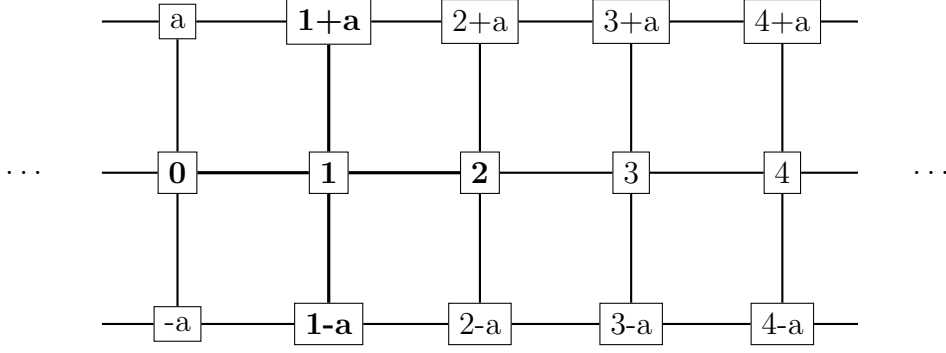

Figure 1: The distance graph $G(\{1, a\})$, $a \geq 3$

1. $\lambda(0) = \lambda(3) = 1$, $\lambda(1) = 2$, $\lambda(2) = 3$.

Since $C(1)$ induces a clique in $G(\{1, a\}^2)$ (depicted in bold in Figure 1), we have

$$\{\lambda(1-a), \lambda(1+a)\} = \{4, 5\},$$

which implies

$$\{\lambda(2-a), \lambda(2+a)\} = \{4, 5\}.$$

(More precisely, $\lambda(2-a) = 9 - \lambda(1-a)$ and $\lambda(2+a) = 9 - \lambda(1+a)$). This implies $\lambda(3-a) = \lambda(3+a) = 2$, a contradiction since $d(3-a, 3+a) = 2$.

2. $\lambda(0) = \lambda(4) = 1$, $\lambda(1) = 2$, $\lambda(2) = 3$, $\lambda(3) = 4$.

As in the previous case we have

$$\{\lambda(1-a), \lambda(1+a)\} = \{4, 5\},$$

which implies

$$\{\lambda(2-a), \lambda(2+a)\} = \{1, 5\}.$$

We then get $\lambda(3-a) = \lambda(3+a) = 2$, again a contradiction.

Therefore, $\chi_2(G(\{1, a\})) = 5$ if and only if 5 do not divide any element of $\{1, a\}^2 = \{1, 2, a-1, a, a+1, 2a\}$. This is clearly the case if and only if $a \equiv 2 \pmod{5}$ or $a \equiv 3 \pmod{5}$.

We finally prove that there exists a 2-distance 6-coloring of $G(\{1, a\})$ for any value of a . We consider three cases, according to the value of $(a \pmod{3})$:

1. $a = 3k$, $k \geq 1$.

Let λ be the $(2a-1)$ -periodic mapping defined by the pattern

$$(123)^k (456)^{k-1} 45.$$

If $\lambda(x) = \lambda(y) = c$, $1 \leq c \leq 5$, then

$$d(x, y) \in \{3q, 0 \leq q \leq k-1\} \cup \{(2a-1)p + 3q, p \geq 1, 1-k \leq q \leq k-1\}.$$

If $\lambda(x) = \lambda(y) = 6$, then

$$d(x, y) \in \{3q, 0 \leq q \leq k-2\} \cup \{(2a-1)p + 3q, p \geq 1, 2-k \leq q \leq k-2\}.$$

Therefore, in both cases, $d(x, y) \notin \{1, 2, a-1, a, a+1, 2a\}$, and thus λ is a 2-distance 6-coloring of $G(\{1, a\})$.

2. $a = 3k + 1, k \geq 1$.

Let λ be the $(2a - 2)$ -periodic mapping defined by the pattern

$$(123)^k(456)^k.$$

If $\lambda(x) = \lambda(y) = c, 1 \leq c \leq 6$, then

$$d(x, y) \in \{3q, 0 \leq q \leq k - 1\} \cup \{(2a - 2)p + 3q, p \geq 1, 1 - k \leq q \leq k - 1\}.$$

Therefore, $d(x, y) \notin \{1, 2, a - 1, a, a + 1, 2a\}$, and thus λ is a 2-distance 6-coloring of $G(\{1, a\})$.

3. $a = 3k + 2, k \geq 1$.

Let λ be the $(2a + 1)$ -periodic mapping defined by the pattern

$$(123)^{k+1}(456)^k 45.$$

If $\lambda(x) = \lambda(y) = c, 1 \leq c \leq 5$, then

$$d(x, y) \in \{3q, 0 \leq q \leq k\} \cup \{(2a + 1)p + 3q, p \geq 1, -k \leq q \leq k\}.$$

If $\lambda(x) = \lambda(y) = 6$, then

$$d(x, y) \in \{3q, 0 \leq q \leq k - 1\} \cup \{(2a + 1)p + 3q, p \geq 1, 1 - k \leq q \leq k - 1\}.$$

Therefore, in both cases, $d(x, y) \notin \{1, 2, a - 1, a, a + 1, 2a\}$, and thus λ is a 2-distance 6-coloring of $G(\{1, a\})$.

This concludes the proof. □

4 The case $D = \{1, a, a + 1\}, a \geq 3$

We study in this section the 2-distance chromatic number of distance graphs $G(D)$ with $D = \{1, a, a + 1\}, a \geq 3$ (note that the case $a = 2$ is already solved by Proposition 5).

When $D = \{1, a, a + 1\}, a \geq 3$, we have $\Delta(G(D)) = 6$ and

$$D^2 = \{1, 2, a - 1, a, a + 1, a + 2, 2a, 2a + 1, 2a + 2\}.$$

We first prove the following:

Theorem 7 *For every integer $a, a \geq 3$,*

$$\chi_2(G(\{1, a, a + 1\})) = 7 = \Delta(G(\{1, a, a + 1\})) + 1$$

if and only if $a \equiv 2 \pmod{7}$ or $a \equiv 4 \pmod{7}$.

Proof. Since $\{1, a, a + 1\}^2 = \{1, 2, a - 1, a, a + 1, a + 2, 2a, 2a + 1, 2a + 2\}$, we get $d \not\equiv 0 \pmod{7}$ for every $d \in \{1, a, a + 1\}^2$ whenever $a \equiv 2 \pmod{7}$ or $a \equiv 4 \pmod{7}$ and thus, by Proposition 1 and Observation 4, $\chi_2(G(\{1, a, a + 1\})) = 7$.

Note that for every $x \in \mathbb{Z}$, the set of vertices

$$C(x) = \{x - a - 1, x - a, x - 1, x, x + 1, x + a, x + a + 1\}$$

induces a clique in $G(\{1, a, a + 1\}^2)$. We now claim that every 2-distance 7-coloring λ of $G(\{1, a, a + 1\})$ is necessarily 7-periodic, that is $\lambda(x + 7) = \lambda(x)$ for every $x \in \mathbb{Z}$. To show that, it suffices to prove that any 7 consecutive vertices $x, \dots, x + 6$ must be assigned distinct colors. Assume to the contrary that this is not the case and, without loss of generality, let $x = 0$. Since vertices 0, 1 and 2 necessarily get distinct colors, we only have four cases to consider (see Figure 2):

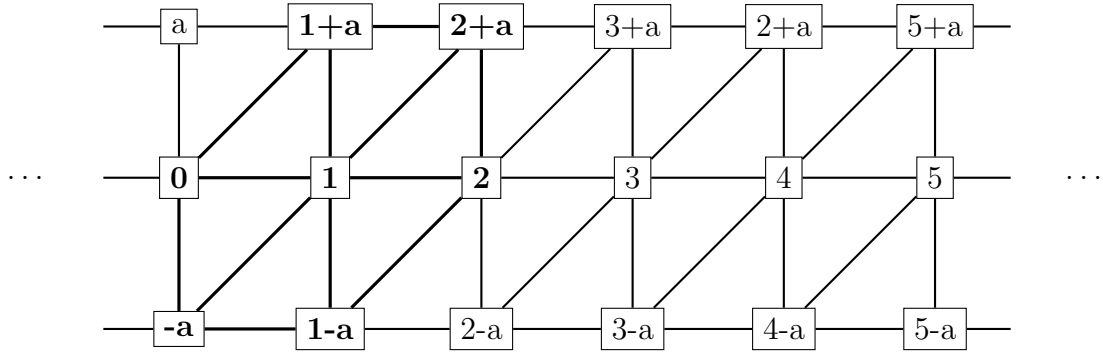

Figure 2: The distance graph $G(\{1, a, a + 1\})$, $a \geq 3$

1. Vertices 0, 1, 2, 3 are colored with the colors 1, 2, 3 and 1, respectively.

We consider two subcases:

- (a) $\lambda(4) = 2$.

Since $C(1)$ induces a clique in $G(\{1, a, a + 1\}^2)$ (depicted in bold in Figure 2), we have

$$\{\lambda(-a), \lambda(1 - a), \lambda(1 + a), \lambda(2 + a)\} = \{4, 5, 6, 7\}.$$

For similar reasons, we also have

$$\{\lambda(2 - a), \lambda(3 - a), \lambda(3 + a), \lambda(4 + a)\} = \{4, 5, 6, 7\}.$$

This implies $\lambda(-a) = \lambda(4 - a)$ or $\lambda(1 + a) = \lambda(5 + a)$. Each of these cases thus corresponds to case 2 below.

- (b) $\lambda(4) \notin \{1, 2, 3\}$.

Assume $\lambda(4) = 4$, without loss of generality. As in the previous subcase, we have

$$\{\lambda(-a), \lambda(1 - a), \lambda(1 + a), \lambda(2 + a)\} = \{4, 5, 6, 7\},$$

and, similarly,

$$\{\lambda(1 - a), \lambda(2 - a), \lambda(2 + a), \lambda(3 + a)\} = \{4, 5, 6, 7\}.$$

Moreover, since $\lambda(4) = 4$, we get

$$\{\lambda(3 + a), \lambda(2 - a)\} \subseteq \{5, 6, 7\}.$$

On the other hand, considering the clique $S(3)$ in $G(\{1, a, a + 1\}^2)$, we also get

$$\{\lambda(4 + a), \lambda(3 - a)\} \subseteq \{5, 6, 7\}.$$

We thus get a contradiction since we only have three available colors for the clique induced by the four vertices $2 - a, 3 - a, a + 3$ and $a + 4$ in $G(\{1, a, a + 1\}^2)$.

2. Vertices 0, 1, 2, 3, 4 are colored with the colors 1, 2, 3, 4 and 1, respectively.

Again considering cliques $C(2)$ and $C(3)$ in $G(\{1, a, a + 1\}^2)$, we get

$$\{\lambda(1 - a), \lambda(2 + a)\} \subseteq \{5, 6, 7\},$$

and

$$\{\lambda(2 - a), \lambda(3 + a)\} \subseteq \{5, 6, 7\},$$

a contradiction since vertices $1 - a, 2 - a, a + 2$ and $a + 3$ induce a clique in $G(\{1, a, a + 1\}^2)$.

3. Vertices $0, 1, 2, 3, 4, 5$ are colored with the colors $1, 2, 3, 4, 5$ and 1 , respectively. Considering the cliques $C(1)$, $C(2)$ and $C(3)$ in $G(\{1, a, a+1\}^2)$, we get

$$\begin{aligned}\{\lambda(-a), \lambda(1-a), \lambda(1+a), \lambda(2+a)\} &= \{4, 5, 6, 7\}, \\ \{\lambda(2-a), \lambda(3+a)\} &\subseteq \{1, \lambda(-a), \lambda(1+a)\} \setminus \{4, 5\}, \\ \{\lambda(3-a), \lambda(4+a)\} &\subseteq \{2, \lambda(1-a), \lambda(2+a)\} \setminus \{4, 5\},\end{aligned}$$

and thus

$$\{\lambda(2-a), \lambda(3+a)\} \subseteq \{1, 6, 7\} \quad \text{and} \quad \{\lambda(3-a), \lambda(4+a)\} \subseteq \{2, 6, 7\}.$$

Assuming that none of cases 1 or 2 occurs, we have two subcases to consider:

- (a) $\lambda(6) = 2$.

Considering the clique $C(4)$ in $G(\{1, a, a+1\}^2)$, we get

$$\{\lambda(4-a), \lambda(5+a)\} \subseteq \{3, \lambda(2-a), \lambda(3+a)\} \setminus \{1, 2\} = \{3, 6, 7\}.$$

If $\{\lambda(4-a), \lambda(5+a)\} = \{3, 6\}$, then

$$\{\lambda(3-a), \lambda(4+a)\} = \{2, 7\},$$

$$\{\lambda(2-a), \lambda(3+a)\} = \{1, 6\},$$

$$\{\lambda(1-a), \lambda(2+a)\} = \{5, 7\}$$

and

$$\{\lambda(-a), \lambda(1+a)\} = \{4, 6\}.$$

If $\lambda(-a) = 6$ then $\lambda(2-a) = 1$ and thus $\lambda(4-a) = \lambda(-a) = 6$ which corresponds to subcase 2. If $\lambda(1+a) = 6$ then $\lambda(3+a) = 1$ and thus $\lambda(5+a) = \lambda(1+a) = 6$ which again corresponds to subcase 2.

The case $\{\lambda(4-a), \lambda(5+a)\} = \{3, 7\}$ is similar and leads to the same conclusion.

Finally, if $\{\lambda(4-a), \lambda(5+a)\} = \{6, 7\}$ then $\lambda(3-a) = \lambda(4+a) = 1$, a contradiction since $d_{G(\{1, a, a+1\})}(4-a, 5+a) = 2$.

- (b) $\lambda(6) = 6$.

Considering the clique $C(4)$ in $G(\{1, a, a+1\}^2)$, we get

$$\{\lambda(4-a), \lambda(5+a)\} \subseteq \{3, \lambda(2-a), \lambda(3+a)\} \setminus \{1, 6\} = \{3, 7\}.$$

This implies

$$\{\lambda(3-a), \lambda(4+a)\} = \{2, 6\},$$

$$\{\lambda(2-a), \lambda(3+a)\} = \{1, 7\},$$

$$\{\lambda(1-a), \lambda(2+a)\} = \{5, 6\}$$

and

$$\{\lambda(-a), \lambda(1+a)\} = \{4, 7\}.$$

If $\lambda(-a) = 7$ then $\lambda(2-a) = 1$ and thus $\lambda(4-a) = \lambda(-a) = 7$ which corresponds to subcase 2. If $\lambda(1+a) = 7$ then $\lambda(3+a) = 1$ and thus $\lambda(5+a) = \lambda(1+a) = 7$ which again corresponds to subcase 2.

4. Vertices $0, 1, 2, 3, 4, 5, 6$ are colored with the colors $1, 2, 3, 4, 5, 6$ and 1 , respectively. Again considering the cliques $C(1)$, $C(2)$ and $C(3)$ in $G(\{1, a, a+1\}^2)$, we get

$$\begin{aligned}\{\lambda(-a), \lambda(1-a), \lambda(1+a), \lambda(2+a)\} &= \{4, 5, 6, 7\}, \\ \{\lambda(2-a), \lambda(3+a)\} &\subseteq \{1, \lambda(-a), \lambda(1+a)\} \setminus \{4, 5\},\end{aligned}$$

and thus

$$\{\lambda(3-a), \lambda(4+a)\} \subseteq \{2, \lambda(1-a), \lambda(2+a)\} \setminus \{4, 5, 6\} = \{2, 7\}.$$

This implies

$$\begin{aligned}\{\lambda(2-a), \lambda(3+a)\} &= \{1, 6\}, \\ \{\lambda(1-a), \lambda(2+a)\} &= \{5, 7\}\end{aligned}$$

and

$$\{\lambda(-a), \lambda(1+a)\} = \{4, 6\}.$$

Therefore,

$$\{\lambda(4-a), \lambda(5+a)\} \subseteq \{3, \lambda(2-a), \lambda(3+a)\} \setminus \{1, 6\} = \{3\},$$

a contradiction since $d_{G(\{1, a, a+1\})}(4-a, 5+a) = 2$.

Therefore, every 2-distance 7-coloring λ of $G(\{1, a, a+1\})$ is necessarily 7-periodic, and thus $\chi_2(G(\{1, a, a+1\})) = 7$ if and only if 7 do not divide any element of $\{1, 2, a-1, a, a+1, a+2, 2a, 2a+1, 2a+2\}$. This is clearly the case if and only if $a \equiv 2 \pmod{7}$ or $a \equiv 4 \pmod{7}$. \square

The following result provides an upper bound on $\chi_2(G(\{1, a, a+1\}))$ for any value of a .

Theorem 8 *For every integer a , $a \geq 3$, $\chi_2(G(\{1, a, a+1\})) \leq 9 = \Delta(G(\{1, a, a+1\})) + 3$.*

Proof. We consider three cases, according to the value of $(a \pmod{3})$:

1. $a = 3k$, $k \geq 1$.

Let λ be the $3a$ -periodic mapping defined by the pattern

$$(123)^k(456)^k(789)^k.$$

If $\lambda(x) = \lambda(y) = c$, $1 \leq c \leq 9$, then

$$d(x, y) \in \{3q, 0 \leq q \leq k-1\} \cup \{3ap+3q, p \geq 1, 1-k \leq q \leq k-1\}.$$

Therefore, $d(x, y) \notin \{1, 2, a-1, a, a+1, a+2, 2a, 2a+1, 2a+2\}$, and thus λ is a 2-distance 9-coloring of $G(\{1, a, a+1\})$.

2. $a = 3k+1$, $k \geq 1$.

Let λ be the $(3a+2)$ -periodic mapping defined by the pattern

$$(123)^k(456)^k7123(789)^{k-1}4568.$$

If $\lambda(x) = \lambda(y) = c$, $1 \leq c \leq 6$, then

$$\begin{aligned}d(x, y) \in & \{3q, 0 \leq q \leq k-1\} \\ & \cup \{3q+2a-1, 1-k \leq q \leq 0\} \\ & \cup \{(3a+2)p+2a-1, p > 0\} \\ & \cup \{(3a+2)p-2a+1, p > 0\} \\ & \cup \{(3a+2)p+3q, p > 0, 1-k \leq q < 0\} \\ & \cup \{(3a+2)p+3q+2a-1, p > 0, 1-k \leq q < 0\} \\ & \cup \{(3a+2)p+3q, p > 0, 0 < q \leq k-1\} \\ & \cup \{(3a+2)p+3q-2a+1, p > 0, 0 < q \leq k-1\}.\end{aligned}$$

If $\lambda(x) = \lambda(y) = 7$, then

$$\begin{aligned} d(x, y) \in & \{3q, 0 \leq q \leq k-2\} \\ & \cup \{3q+4, 0 \leq q \leq k-2\} \\ & \cup \{(3a+2)p+3q-4, p > 0, 2-k \leq q \leq 0\} \\ & \cup \{(3a+2)p+3q+4, p > 0, 0 \leq q \leq k-2\} \\ & \cup \{(3a+2)p+3q, p > 0, 2-k \leq q \leq k-2\}. \end{aligned}$$

If $\lambda(x) = \lambda(y) = 8$, then

$$\begin{aligned} d(x, y) \in & \{3q, 0 \leq q \leq k-2\} \\ & \cup \{3q+a-2, 2-k \leq q \leq 0\} \\ & \cup \{(3a+2)p+a-2, p > 0\} \\ & \cup \{(3a+2)p-a+2, p > 0\} \\ & \cup \{(3a+2)p+3q, p > 0, 2-k \leq q < 0\} \\ & \cup \{(3a+2)p+3q+a-2, p > 0, 2-k \leq q < 0\} \\ & \cup \{(3a+2)p+3q, p > 0, 0 < q \leq k-2\} \\ & \cup \{(3a+2)p+3q-a+2, p > 0, 0 < q \leq k-2\}. \end{aligned}$$

If $\lambda(x) = \lambda(y) = 9$, then

$$d(x, y) \in \{3q, 0 \leq q \leq k-2\} \cup \{(3a+2)p+3q, p \geq 1, 2-k \leq q \leq k-2\}.$$

Therefore, in all these cases, $d(x, y) \notin \{1, 2, a-1, a, a+1, a+2, 2a, 2a+1, 2a+2\}$, and thus λ is a 2-distance 9-coloring of $G(\{1, a, a+1\})$.

3. $a = 3k+2, k \geq 1$.

Let λ be the $(3a+1)$ -periodic mapping defined by the pattern

$$(123)^{k+1}(456)^{k+1}(789)^k 7.$$

If $\lambda(x) = \lambda(y) = c, 1 \leq c \leq 7$, then

$$d(x, y) \in \{3q, 0 \leq q \leq k\} \cup \{(3a+1)p+3q, p \geq 1, -k \leq q \leq k\}.$$

If $\lambda(x) = \lambda(y) = c, 8 \leq c \leq 9$, then

$$d(x, y) \in \{3q, 0 \leq q \leq k-1\} \cup \{(3a+1)p+3q, p \geq 1, 1-k \leq q \leq k-1\}.$$

Therefore, in both cases, $d(x, y) \notin \{1, 2, a-1, a, a+1, a+2, 2a, 2a+1, 2a+2\}$, and thus λ is a 2-distance 9-coloring of $G(\{1, a, a+1\})$.

This concludes the proof. □

From Theorems 7 and 8, we thus get:

Corollary 9 For every integer $a, a \geq 3, a \not\equiv 2, 4 \pmod{7}$,

$$8 \leq \chi_2(G(\{1, a, a+1\})) \leq 9.$$

5 The case $D = \{1, \dots, m, a\}, 2 \leq m < a$

We study in this section the 2-distance chromatic number of distance graphs $G(D)$ with $D = \{1, \dots, m, a\}, 2 \leq m < a$ (note that the case $a = m+1$ is already solved by Proposition 5).

When $D = \{1, \dots, m, a\}$, we have $\Delta(G(D)) = 2m+2$ and

$$D^2 = \{1, 2, \dots, 2m\} \cup \{a-m, a-m+1, \dots, a+m\} \cup \{2a\}.$$

We first prove the following:

Theorem 10 For all integers m and a , $2 \leq m < a$,

$$\chi_2(G(\{1, \dots, m, a\})) = 2m + 3 = \Delta(G(\{1, \dots, m, a\})) + 1$$

if and only if $a \equiv m + 1 \pmod{2m + 3}$ or $a \equiv m + 2 \pmod{2m + 3}$.

Proof. Since $\{1, \dots, m, a\}^2 = \{1, \dots, 2m\} \cup \{a - m, a - m + 1, \dots, a + m\} \cup \{2a\}$, $d \not\equiv 0 \pmod{2m + 3}$ for every $d \in \{1, \dots, m, a\}^2$ whenever $a \equiv m + 1 \pmod{2m + 3}$ or $a \equiv m + 2 \pmod{2m + 3}$, and thus, by Proposition 1 and Observation 4, $\chi_2(G(\{1, \dots, m, a\})) = 2m + 3$.

We now claim that every 2-distance $(2m + 3)$ -coloring λ of $G(\{1, \dots, m, a\})$ is necessarily $(2m + 3)$ -periodic, that is $\lambda(x + 2m + 3) = \lambda(x)$ for every $x \in \mathbb{Z}$. To show that, it suffices to prove that any $2m + 3$ consecutive vertices $x, \dots, x + 2m + 2$ must be assigned distinct colors. Assume to the contrary that this is not the case and, without loss of generality, let $x = 0$. Since vertices $0, 1, \dots, 2m$ necessarily get distinct colors, we only have two cases to consider:

1. Vertices $0, 1, \dots, 2m + 1$ are colored with the colors $1, 2, \dots, 2m + 1$ and 1 , respectively. Note that vertices $m - a$ and $m + a$ are both adjacent to all vertices $0, 1, \dots, 2m$. Hence,

$$\{\lambda(m - a), \lambda(m + a)\} = \{2m + 2, 2m + 3\},$$

which implies

$$\{\lambda(m + 1 - a), \lambda(m + 1 + a)\} = \{2m + 2, 2m + 3\}$$

(more precisely, $\lambda(m + 1 - a) = 4m + 5 - \lambda(m - a)$ and $\lambda(m + 1 + a) = 4m + 5 - \lambda(m + a)$). This implies $\lambda(m + 2 - a) = \lambda(m + 2 + a) = 2$, a contradiction since $d(m + 2 - a, m + 2 + a) = 2$.

2. Vertices $0, 1, \dots, 2m + 1, 2m + 2$ are colored with the colors $1, 2, \dots, 2m + 1, 2m + 2$ and 1 , respectively.

As in the previous case we have

$$\{\lambda(m - a), \lambda(m + a)\} = \{2m + 2, 2m + 3\},$$

which implies

$$\{\lambda(m + 1 - a), \lambda(m + 1 + a)\} = \{1, 2m + 3\}.$$

We thus get $\lambda(m + 2 - a) = \lambda(m + 2 + a) = 2$, again a contradiction.

Therefore, every 2-distance $(2m + 3)$ -coloring λ of $G(\{1, \dots, m, a\})$ is necessarily $(2m + 3)$ -periodic, and thus $\chi_2(G(\{1, \dots, m, a\})) = 2m + 3$ if and only if $2m + 3$ do not divide any element of $\{1, 2, \dots, 2m\} \cup \{a - m, a - m + 1, \dots, a + m\} \cup \{2a\}$. This is clearly the case if and only if $a \equiv m + 1 \pmod{2m + 3}$ or $a \equiv m + 2 \pmod{2m + 3}$. □

For other values of a , we propose the following general upper bound on

Theorem 11 For all integers m and a , $2 \leq m < a$,

$$\chi_2(G(\{1, \dots, m, a\})) \leq 4m + 2 = 2\Delta(G(\{1, \dots, m, a\})) - 2.$$

Proof. Let $a = (2m + 1)k + r$, $0 \leq r < 2m + 1$. We consider four cases, depending on the value of r . In each case, we will provide a periodic 2-distance $(4m + 2)$ -coloring of the distance graph $G(\{1, \dots, m, a\})$.

1. $r < m$.

Let λ be the $(2a - r - m)$ -periodic mapping defined by the pattern

$$[12 \dots (2m + 1)]^k [(2m + 2)(2m + 1) \dots (4m + 2)]^{k-1} (2m + 2)(2m + 3) \dots (3m + r + 2).$$

If $\lambda(x) = \lambda(y) = c$, $1 \leq c \leq 3m + r + 2$, then

$$d(x, y) \in \{q(2m + 1), 0 \leq q \leq k - 1\} \\ \cup \{p(2a - r - m) + q(2m + 1), p \geq 1, 1 - k \leq q \leq k - 1\}.$$

If $\lambda(x) = \lambda(y) = c$, $3m + r + 3 \leq c \leq 4m + 2$, then

$$d(x, y) \in \{q(2m + 1), 0 \leq q \leq k - 2\} \\ \cup \{p(2a - r - m) + q(2m + 1), p \geq 1, 2 - k \leq q \leq k - 2\}.$$

Therefore, in both cases, $d(x, y) \notin \{1, 2, \dots, 2m\} \cup \{a - m, a - m + 1, \dots, a + m\} \cup \{2a\}$, and thus λ is a 2-distance $(4m + 2)$ -coloring of $G(\{1, \dots, m, a\})$.

2. $r = m$.

Let λ be the $(2a - 2m)$ -periodic mapping defined by the pattern

$$[12 \dots (2m + 1)]^k [(2m + 2)(2m + 1) \dots (4m + 2)]^k.$$

If $\lambda(x) = \lambda(y) = c$, $1 \leq c \leq 4m + 2$, then

$$d(x, y) \in \{q(2m + 1), 0 \leq q \leq k - 1\} \\ \cup \{p(2a - 2m) + q(2m + 1), p \geq 1, 1 - k \leq q \leq k - 1\}.$$

Therefore, $d(x, y) \notin \{1, 2, \dots, 2m\} \cup \{a - m, a - m + 1, \dots, a + m\} \cup \{2a\}$, and thus λ is a 2-distance $(4m + 2)$ -coloring of $G(\{1, \dots, m, a\})$.

3. $r = m + 1$.

Let λ be the $(2a + 1)$ -periodic mapping defined by the pattern

$$[12 \dots (2m + 1)]^{k+1} [(2m + 2)(2m + 1) \dots (4m + 2)]^k (2m + 2)(2m + 3).$$

If $\lambda(x) = \lambda(y) = c$, $1 \leq c \leq 2m + 3$, then

$$d(x, y) \in \{q(2m + 1), 0 \leq q \leq k\} \\ \cup \{p(2a + 1) + q(2m + 1), p \geq 1, -k \leq q \leq k\}.$$

If $\lambda(x) = \lambda(y) = c$, $2m + 4 \leq c \leq 4m + 2$, then

$$d(x, y) \in \{q(2m + 1), 0 \leq q \leq k - 1\} \\ \cup \{p(2a + 1) + q(2m + 1), p \geq 1, 1 - k \leq q \leq k - 1\}.$$

Therefore, in both cases, $d(x, y) \notin \{1, 2, \dots, 2m\} \cup \{a - m, a - m + 1, \dots, a + m\} \cup \{2a\}$, and thus λ is a 2-distance $(4m + 2)$ -coloring of $G(\{1, \dots, m, a\})$.

4. $m + 2 \leq r < 2m + 1$.

Let λ be the $(2a - r + m + 1)$ -periodic mapping defined by the pattern

$$[12 \dots (2m + 1)]^{k+1} [(2m + 2)(2m + 1) \dots (4m + 2)]^k (2m + 2)(2m + 3) \dots (m + r + 1).$$

If $\lambda(x) = \lambda(y) = c$, $1 \leq c \leq m + r + 1$, then

$$d(x, y) \in \{q(2m + 1), 0 \leq q \leq k\} \\ \cup \{p(2a - r + m + 1) + q(2m + 1), p \geq 1, -k \leq q \leq k\}.$$

If $\lambda(x) = \lambda(y) = c$, $m + r + 2 \leq c \leq 4m + 2$, then

$$d(x, y) \in \{q(2m + 1), 0 \leq q \leq k - 1\} \\ \cup \{p(2a - r + m + 1) + q(2m + 1), p \geq 1, 1 - k \leq q \leq k - 1\}.$$

Therefore, in both cases, $d(x, y) \notin \{1, 2, \dots, 2m\} \cup \{a - m, a - m + 1, \dots, a + m\} \cup \{2a\}$, and thus λ is a 2-distance $(4m + 2)$ -coloring of $G(\{1, \dots, m, a\})$.

This concludes the proof. □

From Theorems 10 and 11, we thus get:

Corollary 12 *For all integers m and a , $2 \leq m < a$, $a \not\equiv m + 1, m + 2 \pmod{2m + 3}$,*

$$2m + 4 \leq \chi_2(G(\{1, \dots, m, a\})) \leq 4m + 2.$$

6 Discussion

In this paper, we studied 2-distance colorings of several types of distance graphs. In each case, we characterized those distance graphs that admit an optimal 2-distance coloring, that is distance graphs $G(D)$ with $\chi_2(G(D)) = \Delta(G(D)) + 1$. We also provided general upper bounds for the 2-distance chromatic number of the considered graphs.

We leave as open problems the question of completely determining the 2-distance chromatic number of distance graphs $G(D)$ when $D = \{1, a, a+1\}$, $a \geq 3$, or $D = \{1, \dots, m, a\}$, $2 \leq m < a$.

Considering other types of sets D would certainly be also an interesting direction for future research.

Acknowledgement. Most of this work has been done while the first author was visiting LaBRI, thanks to a grant from University of Sciences and Technology Houari Boumediene (USTHB). The second author was partially supported by the Cluster of excellence CPU, from the Investments for the future Programme IdEx Bordeaux (ANR-10-IDEX-03-02).

References

- [1] G. Agnarsson and M.M. Halldórsson. Coloring powers of planar graphs. *SIAM J. Discrete Math.* 16(4):651–662 (2003).
- [2] M. Bonamy, B. Lévêque and A. Pinlou. 2-distance coloring of sparse graphs. *J. Graph Theory* 77(3):190–218 (2014).
- [3] M. Bonamy, B. Lévêque and A. Pinlou. Graphs with maximum degree $\Delta \geq 17$ and maximum average degree less than 3 are list 2-distance $(\Delta + 2)$ -colorable. *Discrete Math.* 317:19–32 (2014).
- [4] O.V. Borodin and A.O. Ivanova. 2-distance $(\Delta + 2)$ -coloring of planar graphs with girth six and $\Delta \geq 18$. *Discrete Math.* 309:6496–6502 (2009).
- [5] T. Calamoneri. The $L(h, k)$ -labelling problem: An updated survey and annotated bibliography. *The Computer Journal* 54(8):1344–1371 (2011).
- [6] Z. Dvořák, D. Král, P. Nejedlý, and R. Škrekovski. Coloring squares of planar graphs with girth six. *European J. Combin.* 29(4):838–849 (2008).
- [7] F. Kramer and H. Kramer. Un problème de coloration des sommets d'un graphe. *C. R. Acad. Sci. Paris A* 268(7):46–48 (1969).
- [8] F. Kramer and H. Kramer. A survey on the distance-coloring of graphs. *Discrete Math.* 308:422–426 (2008).
- [9] K.W. Lih and W.F. Wang. Coloring the square of an outerplanar graph. *Taiwan. J. Math.* 10(4):1015–1023 (2006).
- [10] D. D.-F. Liu. From rainbow to the lovely runner: A survey on coloring parameters of distance graphs. *Taiwanese J. Math.* 12(4):851–871 (2008).

- [11] H. Walther. Über eine spezielle Klasse unendlicher Graphen. In K. Wagner and R. Bodendiek, eds, *Graphentheorie*, vol. 2, pp. 268–295 (1990), Bibl. Inst., Mannheim.
- [12] W.F. Wang and K.W. Lih. Labeling planar graphs with conditions on girth and distance two. *SIAM J. Discrete Math.* 17(2):264-275 (2003).
- [13] G. Wegner. Graphs with given diameter and a colouring problem. Technical Report, University of Dortmund (1977).
- [14] X. Zhu. Circular chromatic number of distance graphs with distance sets of cardinality three. *J. Graph Theory* 41(3):195–207 (2002).