



**HAL**  
open science

## Networks and Games for Precision Medicine

Célia Biane, Franck Delaplace, Hanna Klaudel

► **To cite this version:**

Célia Biane, Franck Delaplace, Hanna Klaudel. Networks and Games for Precision Medicine. 2016.  
hal-01276715v2

**HAL Id: hal-01276715**

**<https://hal.science/hal-01276715v2>**

Preprint submitted on 27 Feb 2016

**HAL** is a multi-disciplinary open access archive for the deposit and dissemination of scientific research documents, whether they are published or not. The documents may come from teaching and research institutions in France or abroad, or from public or private research centers.

L'archive ouverte pluridisciplinaire **HAL**, est destinée au dépôt et à la diffusion de documents scientifiques de niveau recherche, publiés ou non, émanant des établissements d'enseignement et de recherche français ou étrangers, des laboratoires publics ou privés.



Distributed under a Creative Commons Attribution - NonCommercial 4.0 International License

# Networks and Games for Precision Medicine

Célia Biane<sup>a</sup>, Franck Delaplace<sup>a,\*</sup>, Hanna Klaudel<sup>a</sup>

<sup>a</sup>*IBISC Lab, 23 boulevard de France 91037 Evry, Evry Val d'Essonne University, France*

---

## Abstract

Recent advances in omics technologies provide the leverage for the emergence of precision medicine aiming at personalizing therapy to patient. In this undertaking, computational methods play a central role for assisting physicians in their clinical decision making by combining data analysis and systems biology modelling. Complex diseases such as cancer or diabetes arise from the intricate interplay of various biological molecules. Therefore assessing drug efficiency involves studying the effects of elementary perturbations caused by diseases on relevant biological networks.

In this paper, we propose a computational framework called *network action game* applied to best drug selection problem combining game theory and discrete models of dynamics (Boolean networks). The decision-making is modeled using game theory that defines the process of drug selection among alternative possibilities, while Boolean networks are used for modeling the effects of the interplay between disease and drugs actions on the patient molecular system. The actions/strategies of disease and drugs are focused on arc alteration of the interactome. The efficiency of this framework has been evaluated for drug prediction on a model of breast cancer signaling.

*Keywords:* Precision Medicine, Network Medicine, Game theory, Boolean Network, Therapy Prediction, Systems Biology, Cancer Therapy

---

\*Corresponding author

*Email addresses:* [celia.biane@ibisc.univ-evry.fr](mailto:celia.biane@ibisc.univ-evry.fr) (Célia Biane),  
[franck.delaplace@ibisc.univ-evry.fr](mailto:franck.delaplace@ibisc.univ-evry.fr) (Franck Delaplace ),  
[hanna.klaudel@ibisc.univ-evry.fr](mailto:hanna.klaudel@ibisc.univ-evry.fr) (Hanna Klaudel)

## 1. Introduction

The analysis of the patient omics profile (genome, metabolome, proteome, etc.) would become a standard for molecular based diagnosis and treatment tailored to patient by contrast to a “one-size-fits-all” strategy based on a one-to-one correspondence between disease and drug [18, 27]. *Precision medicine* is an emerging branch of medicine based on omics analysis aiming at improving clinical decision-making by designing new tools for the customization of therapies and their risk/benefit assessment. Addressing this challenge puts the focus on the causality study of the pathogenesis at molecular level.

However, the relationship between genomic information and disease phenotype remains elusive. Indeed, a disease phenotype is rarely a consequence of an abnormality in a single gene product but involves complex interplays of various biological molecules [4]. For instance, patients with sickle cell anemia, which is caused by a unique well-defined mutation in a single gene (classic Mendelian disease) can exhibit highly variable phenotypes in the clinic [2, 36]. This variability is due to the interaction of the mutated gene with other individual-dependant genetic variants [37, 36]. Therefore, understanding the pathogenesis at molecular level requires to conceive frameworks facilitating the discovery of causes altering the molecular systems of a living organism. This challenge logically focuses on biological networks modelling the causal interplays of molecules [12].

The main approaches in this field study the location of dysfunctional molecules in networks and on the nature of network alterations leading to disease.

The works [3, 4, 19] study the formation of specific subnetworks, called module delineating the disease propagation. The hypothesis motivating the approach is that modules are considered as plausible support of integrated molecular function [26, 11]. Besides some evidences, [33] confirm the fact that proteins involved in the same disease have a high propensity to interact forming a tightly interconnected entity in the interactome. Thereby, disease should likely alter a functional module or being themselves modules supporting a dys-functionality (disease modules).

In [51], a network-perturbation approach is used to explain molecular dysfunctions underlying human disease. The mutations causing genetic defects are expressed as actions on edges and nodes of the interactome. Schematically, a mutation leading to inoperative protein is modelled by a node deletion while mutations inducing loss or gain of interaction are respectively modelled

by an edge deletion or addition (*edgetic* perturbation). They uncovered experimental and computational evidences that these network alterations occur in human Mendelian diseases.

It is worth noting that the perturbation on networks induced by diseases are formalized by elementary topological modifications: nodes or edges are added or cut. Hence the complexity of disease relies on the impact of these topological modifications on the biological processes affecting their evolution. For example, cancer cells acquire the capability to sustain proliferative signalling notably by defecting feedback loops that hamper the regulation of the cell division [20]. Therefore, a deeper understanding of disease/therapy mechanism requires to enforce the prediction capabilities on the incidence of these elementary actions in the underlying dynamics of networks.

In this paper, we combine two theoretical frameworks: *game theory* and discrete models of dynamics (*Boolean networks*) to determine the best drug to administrate to a patient. The clinical decision-making is modeled using game theory, that defines the process of selection by the *players* of an action among alternative possibilities [32, 9], while Boolean networks are used for modelling the effects of the interplay between disease and drugs on the patient molecular system. Boolean networks are used in biology to study the dynamics of molecular networks (modeled as *interaction graphs*), which represent functional interactions between molecules [43, 10, 1]. Such a dynamics evolves towards equilibria interpreted at the molecular level as the patient health condition or illness. The physician and the disease are considered as *players* of a game, each of them having *strategies* of action that correspond to a drug administration and to a genetic mutation, respectively. In a game, combinations of strategies, called *strategy profiles*, modify the patient interaction graph, therefore modifying the associated Boolean dynamics and its equilibria. From the assessment of biomarkers at these equilibria, players' preferences are determined, and then, the interpretation of the ordinal Nash equilibrium leads to the discovery of the best physician action (drug). Figure 1 recalls the main steps of the framework described above.

The paper is structured as follow: after recalling the main features of Boolean network and ordinal game, we detail the theoretical framework called *network action game* in Section 2 and show its application to drug prediction in breast cancer in Section 3.

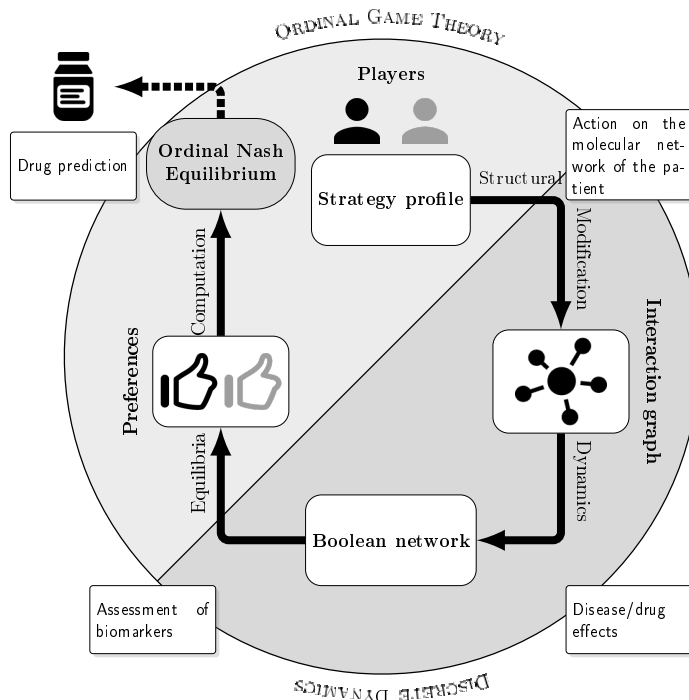

Figure 1: Overview of the *network action game* method.

## 2. *Network action game*

We first introduce the two models composing the *network action game* framework: Boolean networks and ordinal game theory then show their coupling.

### 2.1. *Boolean networks*

A *Boolean network* is a discrete dynamical system of a population of agents defined by a family of propositional formulas determining the evolution of the agents. The dynamics is defined by a transition system where Boolean vectors represent the possible states of the agents and transitions represent their evolution.

Let  $A$  be a set of agents. A (Boolean) state of  $a \in A$  is defined as a mapping  $s: A \mapsto \mathbb{B}$  associating to an agent in  $A$  a value from  $\mathbb{B}$ .

Let  $F = (f_a)_{a \in A}$  be a family of propositional formulas, each  $f_a$  defining the updated state of  $a$  depending on the states of other agents (seen as

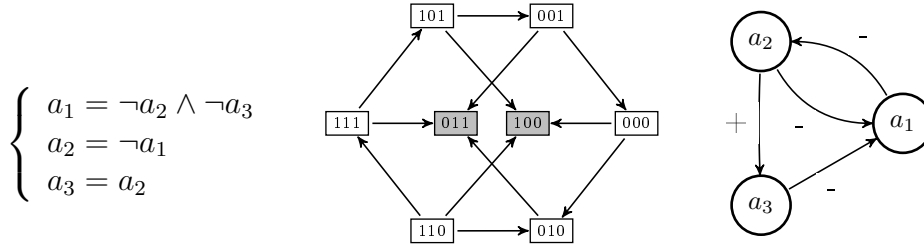

Figure 2: A Boolean network, its model of dynamics and associated interaction graph.

propositional variables), *cf.*, Figure 2. An asynchronous<sup>1</sup> *Boolean network* is defined as a pair  $\langle A, F \rangle$ . Its model of dynamics is a labelled transition system  $(S, \xrightarrow{\cdot}, A)$  where the transition relation labelled by agent  $a$ ,  $\xrightarrow{a}$ , updates the state of agent  $a$  (*i.e.*,  $s[a] = f_a(s)$ ). Hence the global dynamics is the union of the transitions labelled by agents (*i.e.*,  $\xrightarrow{\cdot} = \bigcup_{a \in A} \xrightarrow{a}$ ).

The *signed interaction graph* associated to  $F$ ,  $G_F = \langle A, \xrightarrow{\cdot}, \delta \rangle$  represents all the signed interactions between agents. The sign of the arc is given by a labelling function  $\delta$  and may be  $+$  for increasing relation,  $-$  for decreasing one and  $\pm$  otherwise. Such a graph can be inferred from the syntax of the propositional formulas<sup>2</sup>, where  $a_i \xrightarrow{-} a_j$  stands for the occurrence of the negative literal  $\neg a_i$  in  $f_{a_j}$ ,  $a_i \xrightarrow{+} a_j$  for the occurrence of the positive literal  $a_i$  in  $f_{a_j}$ , and  $a_i \xrightarrow{\pm} a_j$  for both.

A state  $s$  is an *equilibrium* for  $\xrightarrow{\cdot}$ , if it may be reached infinitely often, *i.e.*,  $\forall s' \in S : s \xrightarrow{*} s' \implies s' \xrightarrow{*} s$ , where  $\xrightarrow{*}$  denotes the reflexive and transitive closure  $\xrightarrow{\cdot}$ . We denote by  $E_{\xrightarrow{\cdot}}$  the set of all equilibria of  $\xrightarrow{\cdot}$ . An *attractor* is a set of equilibria that are mutually reachable and a *steady state* is an attractor of cardinality 1. In Figure 2, the states  $(1, 0, 0)$  and  $(0, 1, 0)$  are steady states.

## 2.2. Ordinal game

An ordinal game models strategic decision-making based on the definition of a *preference relation* amongst combination of *players' strategies*. Each *player* has a set of possible *strategies* and a *strategy profile* represents a partic-

<sup>1</sup>Asynchronous means that the state of at most one agent is updated at each transition.

<sup>2</sup>in disjunctive normal form

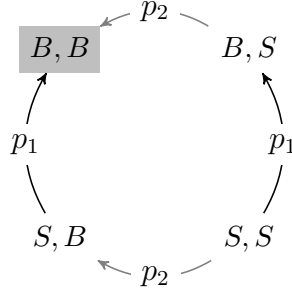

Figure 3: The statement of the prisoner's dilemma is as follows: two suspects (*i.e.*, Players  $p_1$  and  $p_2$ ) are arrested without the possibility to interact and are offered to choose between two strategies: betrayal (strategy  $B$ ) by testifying that the other committed the crime or remaining silent ( $S$ ). A prison sentence, for each player, is associated to the possible strategy profiles: if both players betray (strategy profile  $B, B$ ), they serve 2 years in prison, if they both remain silent ( $S, S$ ), they serve 1 year, if  $p_1$  betrays but  $p_2$  remains silent ( $B, S$ ),  $p_1$  is set free and  $p_2$  serve 3 years and *vice versa*. the preference is governed by the expectation of minimizing their prison sentence leading to the above preference graph where the Nash equilibrium is highlighted in grey.

ular combination of strategies. A *preference relation* defines the preference, for a player, between each pair of strategy profiles. Figure 2.2 illustrates the application of the ordinal game theory for the *prisoner's dilemma*.

Formally, an *ordinal game* is a triple  $\langle P, (C_p)_{p \in P}, (\preceq_p)_{p \in P} \rangle$  where:

- $P$  is a set of players;
- for each player  $p \in P$ ,  $C_p$  is a non-empty set of strategies  $c_p$  of player  $p$ . The set  $C_P = C_{p_1} \times \dots \times C_{p_{|P|}}$  represents the set of all *strategy profiles*;
- for each player  $p \in P$ , the relation  $\preceq_p: C_P \times C_P$  is a transitive and reflexive relation (pre-order) on strategy profiles called *preference relation* of player  $p$ .

In the sequel, we denote by  $c_{-p}$  the strategy profile  $c$  restricted to strategies of players in  $P \setminus \{p\}$ . For each player, the preference relation is restricted to strategy profiles where only his/her own strategy may differ:

$$\begin{aligned} \forall p \in P : c \preceq_p c' &\implies c_{-p} = c'_{-p} \wedge \\ c_{-p} \neq c'_{-p} &\implies (c \not\preceq_p c' \wedge c' \not\preceq_p c). \end{aligned} \quad (1)$$

The solution concept of an ordinal game is an *ordinal Nash equilibrium*, namely a strategy profile  $c^*$  such that by considering the opponents' choices, a player may only deviate into another Nash equilibrium. In the prisoner's dilemma example, such strategy profile corresponds to (B,B) where the prisoners betray each other (highlighted in grey in Figure 2.2).

The ordinal Nash equilibria may form a cluster of strategy profiles where the preference of the players changes to reach another strategy profile inside the cluster. Such situation may represent an absence of consensus (*i.e.*, a single strategy profile) amongst a subset of players choices. Hence, by considering the global preference relation ( $\preceq = \left( \bigcup_{p \in P} \preceq_p \right)^*$ ), the ordinal Nash equilibria are equivalent in the cluster. Formally, a strategy profile  $c^* \in C_P$  is an ordinal Nash equilibrium if:  $\forall c \in C_P : c \preceq c^* \iff c^* \preceq c$ . In [34], the authors propose a computational definition of the ordinal Nash equilibrium as the strategy profiles belonging to a terminal strongly connected component of a graph corresponding to the union of the preferences of players.

### 2.3. Network action game

Our framework, called *network action game*, defines an ordinal game complying to two founding principles:

First, each strategy profile  $c \in C_P$  is associated to a Boolean network  $\langle A, F^c \rangle$  giving rise to the unique dynamics  $(S, \rightarrow_c)$  and its set of equilibria  $E_{\rightarrow_c}$ . The preference relation  $\preceq_p$  between strategy profiles  $c$  and  $c'$ , for each player  $p$ , is deduced from an assessment of these equilibria. More precisely,  $\preceq_p$  is defined from a pre-order  $\sqsubseteq_p$  on sets of equilibria  $E_{\rightarrow_c}$  and  $E_{\rightarrow_{c'}}$ , as follows:

$$c \preceq_p c' \stackrel{\text{def}}{=} E_{\rightarrow_c} \sqsubseteq_p E_{\rightarrow_{c'}} \wedge c_{-p} = c'_{-p}. \quad (2)$$

The second principle is directly related to the biological network perturbation scheme mentioned in the introduction. Actually, the effect of a strategy profile  $c$  is instantiated by an interaction graph structural modification involving *arc addition* and *arc deletion* as basic actions. They are interpreted as a functional modification of the Boolean network defining  $F^c$ . More precisely, the structural modification is implemented by the sole operation of deletion applied on a *saturated Boolean network*  $F = (f_a)_{a \in A}$ . Its interaction graph  $G_F = \langle A, \rightarrow \rangle$  includes all the arcs inserted in order to instantiate structurally the strategy profiles, *i.e.*,

$$\rightarrow = \{a_i \rightarrow a_j \mid \exists c \in C_P : \Omega_c(a_i \rightarrow a_j)\}, \quad (3)$$



where  $\Omega_c(a_i \rightarrow a_j)$  is a predicate, which is true if arc  $a_i \rightarrow a_j$  is added by strategy profile  $c$ , and false if the arc is deleted. Arc addition is thus interpreted as maintaining the corresponding arc in the saturated Boolean network. Hence, each strategy profile  $c$  gives rise to a Boolean network  $F^c$  obtained from  $F$  by replacing variable  $a_i$  by 0 in  $f_{a_j}$  for each deletion of arc  $a_i \rightarrow a_j$ . In other words, an arc deletion is functionally interpreted as cancellation of the effect of source  $a_i$  on target  $a_j$ .

#### 2.4. Example

The following example illustrates a typical use of the *network action game*. Let us consider a two-players *network action game* with the saturated Boolean network defined in (Figure 2).

$$A = \langle \{a_1, a_2, a_3\}, F = (a_1 = \neg a_2 \wedge \neg a_3, a_2 = \neg a_1, a_3 = a_2) \rangle.$$

Each player has two strategies: a particular one,  $\alpha$  for  $p_1$ ,  $\beta$  for  $p_2$  and an identical one  $\epsilon$ . Each strategy  $c_p$  of player  $p$  is interpreted as a function assigning to each arc a positive or negative strength (*cf.*, Table 1). They are used to assess whether arcs are removed or maintained.

	$a_1 \rightarrow a_2$	$a_2 \rightarrow a_1$	$a_3 \rightarrow a_1$	$a_2 \rightarrow a_3$
$\epsilon$	1	-1	1	1
$\alpha$	1	2	-2	1
$\beta$	1	2	1	-2

Table 1: Strength of arcs per strategies.

Thus, predicate  $\Omega_c$  is defined using the sum of the strengths assigned by players' strategies to the arcs: a positive sum indicates an addition of the arc, while a negative or null indicates a deletion. Formally, for each arc  $a_i \rightarrow a_j$ :

$$\Omega_c(a_i \rightarrow a_j) = \sum_{p \in P} c_p(a_i \rightarrow a_j) > 0.$$

Then, for each strategy profile  $c \in \{(\epsilon, \epsilon), (\alpha, \epsilon), (\epsilon, \beta), (\alpha, \beta)\}$  we compute  $F^c$  from  $F$  using  $\Omega_c$ . The resulting  $F^c$  are shown in Figure 2.4 together with their corresponding interaction graphs and Boolean models of dynamics. The equilibria  $E_{\rightarrow_c}$  are highlighted in grey.

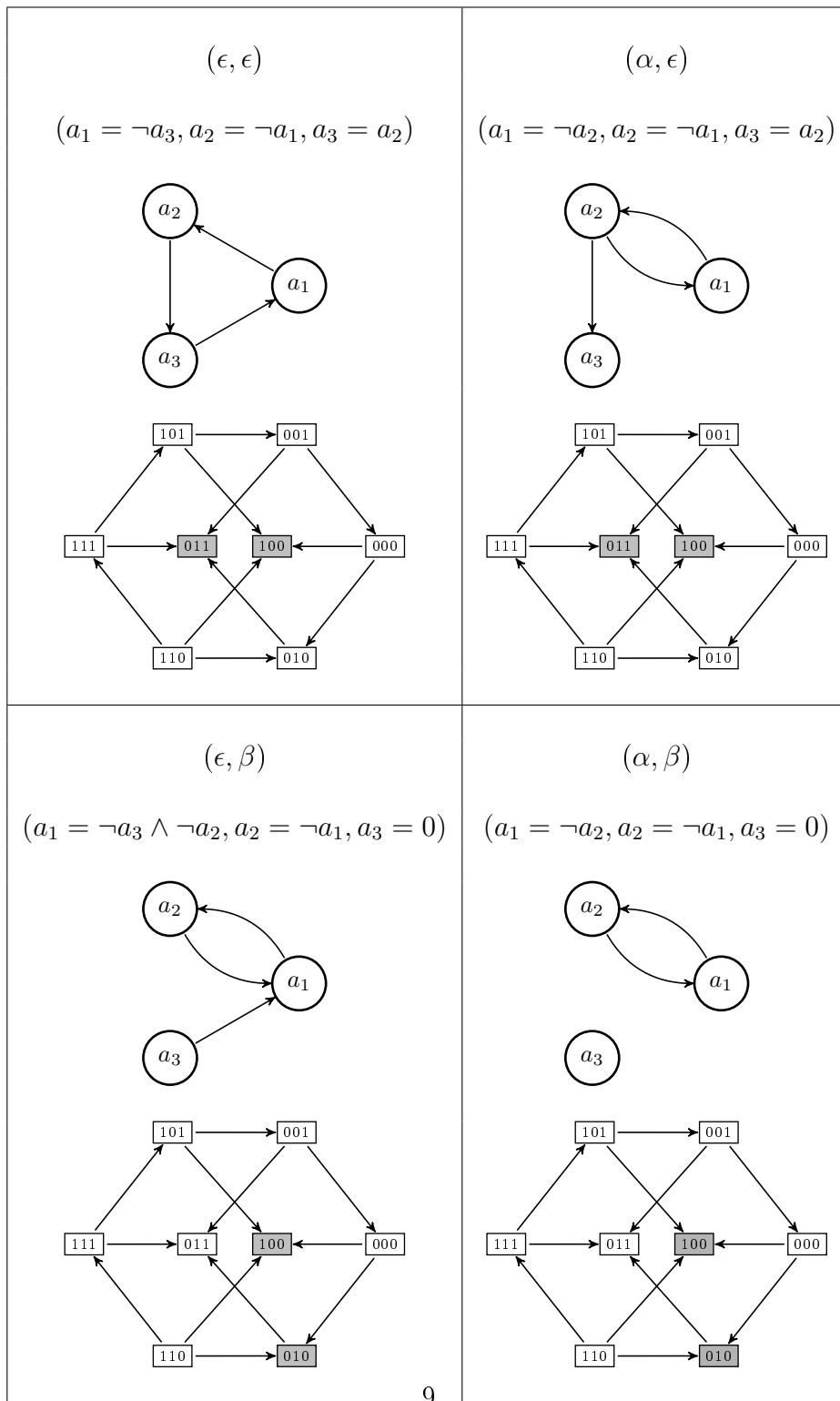

Figure 4: *Network action game* and associated boolean networks.

In order to compute the preferences  $\preceq_p$  on strategy profiles, see (2), we consider, for each player  $p \in P$ , a score function  $\sigma_p$  on states in  $S$ .  $\sigma_{p_1}$  is defined here as the number of 1s in a state expressing  $p_1$ 's preference while  $\sigma_{p_2}$  is defined as the number of 0s in a state. Hence, if the maximum score on  $E_{\rightarrow_c}$  is less or equal than the minimum score on  $E_{\rightarrow_{c'}}$ , then we have  $c \preceq_p c'$ , meaning that player  $p$  prefers  $c'$  to  $c$ . More precisely, with  $\min_{\sigma_p}$  of a set of states  $E \subseteq S$  defined as  $\min_{\sigma_p}(E) = \min(\{\sigma_p(s) | s \in E\})$ , and analogously for  $\max_{\sigma_p}$ , we have:

$$c \preceq_p c' \stackrel{\text{def}}{=} \max_{\sigma_p}(E_{\rightarrow_c}) \leq \min_{\sigma_p}(E_{\rightarrow_{c'}}) \wedge c_{-p} = c'_{-p}. \quad (4)$$

The union<sup>3</sup> of the preference relations of  $p_1$  and  $p_2$  is represented as a graph where the preferences are represented as arcs between strategy profiles and labelled by the player in Figure 5, with the ordinal Nash equilibrium (in gray).

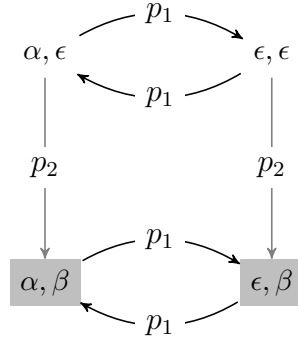

Figure 5: Preference graph. The arcs representing the preferences are labelled by the player. The nodes are strategy profiles. The Nash equilibria are in gray.

### 3. Network action game applied to best drug selection in breast cancer

In this section, after introducing the modeling principles, we describe a model of Breast Cancer (BC) and show the application of *network action game* to drug selection.

---

<sup>3</sup>which is equivalent to the transitive reduction of the global preference relation.

### 3.1. Modeling Principles

We consider a two-players network action game where the players are the Physician and the Disease whose respective strategies correspond to different subtypes of disease and drugs. Hence a strategy profile is a combination (Drug, Disease). Each of such profiles acts on the patient by disrupting his interactome network and the disruptions are formally interpreted as addition or deletion of arcs [51]. Each strategy profile is thus associated to an interactome network whose dynamics is modeled by a Boolean network, The  $(\epsilon, \epsilon)$  strategy profile leads to the healthy Boolean network and corresponds to a situation where neither the Disease nor the Physician acts.

From a systems biology perspective, the cell phenotype arises from the interactome network [46] and a main assumption in Boolean network modeling is that the equilibria of the dynamics are representative of this phenotype [44]. We therefore assess the effects of the interactome disruption on the phenotype by considering the equilibria of the Boolean networks associated to each strategy profile. To assess the result of the profile actions to predict the efficiency of a drug, a score is defined on the state of some molecules assimilated to biomarkers in Precision Medicine [27, 16]. By comparing the scores at the equilibria of the dynamics, we determine the preferences of the players on strategy profiles.

Obviously, a drug is efficient when the disease has disappeared permanently. The appropriate therapy is selected by detecting profiles, where the disease has no option but to prefer its disappearance under the action of the drug. Such profiles correspond to  $(Drug, \epsilon)$ , which are Ordinal Nash equilibria reflecting a stable condition. Hence, the best association between a drug and a disease is given by a profile  $(Drug, Disease)$ , from which Disease player prefers the Ordinal Nash equilibrium  $(Drug, \epsilon)$  and the Physician player has no incentive to modify the selected drug.

### 3.2. Description of the Breast cancer model

#### 3.2.1. Overview

BC tumors are classified in molecular subtypes associated to specific genetic events leading to the disruption of the signalling network controlling the cell proliferation phenotype [20, 6]. The targeted drugs prescribed to treat BC tumors are inhibitors of specific molecular targets that impair the proliferation of tumoral cells. We constructed a signalling network involved

in the control of breast cell proliferation and modeled the perturbations induced by the genetic events and targeted drugs as deletion or addition of arcs in this signalling network.

The deletion of a gene is modelled as the deletion of all the input or output arcs of the node corresponding to the protein encoded in this gene and the over-expression of a protein is modelled by an addition of an arc between a node the state of which is fixed to 1 to the protein encoded in the gene. As drugs are inhibitors of specific molecular targets [21, 35], their actions are modelled as the deletion of the arcs surrounding their targets in the signalling network. The joint action of disease and physician follows the same procedure as Example 2.4: each player assigns a strength on arcs and if the sum of the strengths is positive the arc is added or maintained, otherwise it is deleted. To determine the effects of a strategy profile on the cell proliferation phenotype, the model of the dynamics is defined for the *saturated Boolean network* representing the signalling network comprising all the possible interactions between proteins.

Schematically, the efficiency of an anticancer drug depends on its ability to impair the proliferation of tumoral cells [21, 35] and, from a Darwinian point-of-view, we can assume that a tumoral cell has an “incentive” in proliferating [6]. We therefore define a score function on the biomarkers of cellular proliferation to assess the benefits of drugs and breast cancer strategies for each player. These scores are opposite for both players: the worst for the disease is the best for the physician and *vice versa*.

In the following, we describe the reconstruction of the healthy signalling network, the actions of drugs and BC subtypes, the saturated Boolean network and the score functions for each player.

### 3.2.2. *Healthy signalling network*

Based on the literature and the KEGG Database [23], we reconstructed a healthy signaling network representing the control of a breast cell proliferation phenotype in response to stress. We focused on the p53 [17, 39], PI3K/Akt [14, 38] and BRCA [49, 13] signalling because they are involved in cell proliferation control and are commonly associated with cancers. In this signalling network model, the different pathways collaborate to regulate the activation of two targets: Cyclin D1 and Bax which are respectively the regulator of the G1/S transition during mitosis [30] and a pro-apoptotic factor initiating apoptosis [15]. The interaction graph representing the 11 proteins and 14 interactions of this healthy signaling network is shown on Figure 6.

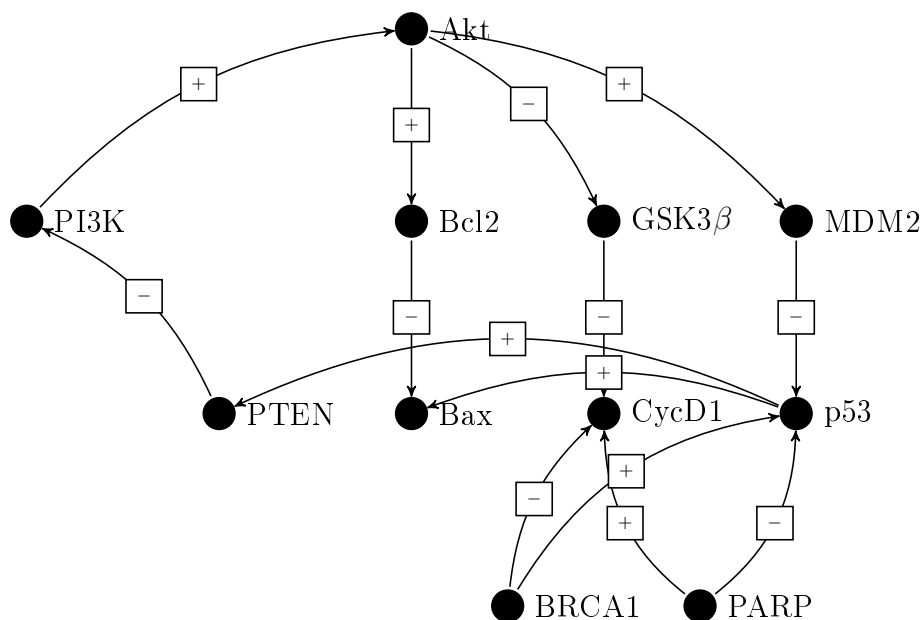

Figure 6: **Model of a breast cell healthy signalling network.** The PI3K/Akt pathway is a phosphorylation cascade that promotes cell cycle progression through the inactivation of GSK3 $\beta$  and prevents apoptosis through the activation of Bcl2, an inhibitor of Bax [8]. The PI3K/Akt pathway interacts with p53 signalling through the activation of its inhibitor Mdm2 [28]. In turn, p53 inhibits PI3K signalling through the activation of its inhibitor PTEN [41], therefore forming a loop [25, 7]. p53 is also involved in the activation of apoptosis through direct activation of Bax transcription [45, 5]. BRCA1 increases Bax activation transcription through p53 activation [49, 29]. BRCA is also involved in cell cycle arrest at the G1/S checkpoint [29, 13], this mechanism is modelled by an inhibition of CycD1 by BRCA1. Finally, PARP inhibition induces cell cycle arrest and enhances cell death in a p53-dependent manner [31] and this is modeled as PARP activation of Cyclin D1 and PARP inhibition of p53.

### 3.2.3. Actions of BC and drugs on the signalling network

Three different subtypes of Breast cancer are defined based on the genetic signature of the tumoral cells: ER positive, HER2 positive and BRCA1-deficient breast cancer cells and are treated with three different drugs: Tamoxifen, Trastuzumab and Olaparib [21]. The drugs are targeted inhibitors: they inhibit specific molecular targets, respectively ER, HER2 and PARPs [21]. Their actions are modeled as deletions of the edges connecting the drugs' targets to their own targets. ER-positive BC cells overexpress the gene coding the Estrogen Receptor (ER) while HER2-positive BC cells overex-

press the gene coding for the Human Epidermal Receptor-2 (HER2) and BRCA1-deficient BC cells are characterized by mutations in both alleles of the BRCA1 gene leading to a deficiency of BRCA1 protein [48]. We modeled these diseases' actions as additions of edges between ER and HER2 nodes and their targets and by the deletion of edges connecting the BRCA1 node to its targets. The actions and their strength are shown in Table 4 (for BC) and Table 3 (for the physician) in Appendix. Figure 6 details the interaction graph in health condition. The saturated interaction graph comprising all the possible interactions is shown on Figure 8 and the formulas of the saturated Boolean network for each protein are given in Table 2 of Appendix.

#### *3.2.4. Score functions on cell proliferation biomarkers*

Cell proliferation can be considered as the balance between mitosis and apoptosis. Schematically, we can distinguish four proliferation phenotypes: quiescence, dormancy, division and death. A dividing cell enters mitosis and inhibits apoptosis, a dying cell triggers apoptosis and stops mitosis, a quiescent cell undergo neither mitosis nor apoptosis and a dormant cell balance mitosis with apoptosis [40]. We define the score functions for each player on the states of the Cyclin D1 and Bax that can be considered as biomarkers of these two cell processes [30, 47]. We assigned, to the player Disease, a maximal score when mitosis is active and apoptosis is inactive (the cancer cell is proliferating) and a minimal score when mitosis is inactive and apoptosis is active (the cell is dying). Conversely, the Physician has a maximal score when the cell dies and a minimal score when the cell divides. As cancer cells in quiescent and dormant states are responsible for relapses occurring many years after the treatment and healing of the patient [40], we defined intermediate and opposite scores for both players when the cell is in a quiescent or dormant phenotype. The scores for each player are given in Table 5 of the Appendix.

#### *3.3. Application of network action game on the BC model*

The comparison of the scores, for each player, at the equilibria of the dynamics (with Equation 4) determine the players' preference relations on strategy profiles. Figure 7 shows a graph representing the preference relation obtained from the application of the network action game on the BC model. On this graph, the nodes represent strategy profiles (Drug, BC subtype) and the arcs represent BC preferences (gray) and the physician preferences (black).

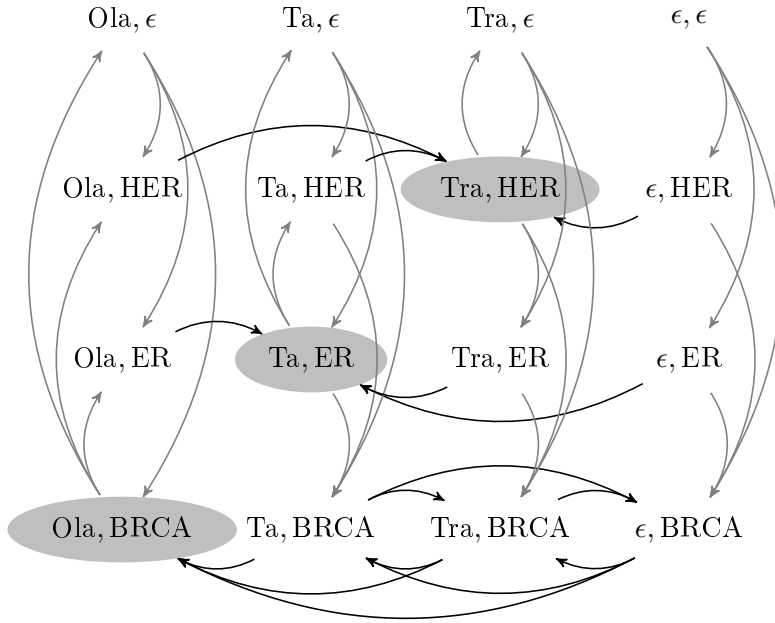

Figure 7: Preference graph

On the preference graph, one can observe that BC does not prefer a strategy profile corresponding to a cancer treated with a drug (Tra,HER ; Ola,BRCA ; Ta,ER ; highlighted in grey) to a strategy profile corresponding to its absence of action (Tra,epsilon ; Ola,epsilon ; Ta,epsilon respectively). BC is unable to discriminate between a healthy and a treated state with a disease in these situations and we therefore interpret them as the efficiency of the drug. Moreover, the physician does not change his strategy while on Tra,HER and Ta,ER or Ola,BRCA. Also notice that Tra,epsilon, Ola,epsilon, Ta,epsilon are Ordinal Nash equilibria, indicating a situation where the disease has permanently disappeared in presence of these drugs.

Therefore from the preference graph, we can conclude that Trastuzumab is efficient to heal HER cancer, Tamoxifen for ER cancer and Olaparib for BRCA1 cancer. These conclusions are confirmed by clinical practice since the associations described by these strategy profiles are currently used in the clinic [21]. Hence, in this case, the network action game framework has inferred the best drug strategy selection for three types of different mutations causing BC without explicit knowledge on these associations.



## Conclusion

Network action game couples Boolean networks with game theory in order to predict the best therapy. Arc addition/deletion on the interactome is considered here as a paradigm of the causal explanation of disease and therapy prediction. The efficiency of the framework has been assessed on breast cancer model. As a result we show that the proposed associations between drugs and malignant mutations exactly match to those found in literature.

Future prospects mainly concern the application of the network action game to drug re-purposing and design. The former investigates the repositioning of drugs to new indications leading to substantially reduce the duration and the cost of their development cycle since the necessary analysis of the molecules was already performed. This may be addressed by generalizing the method applied for breast cancer. Indeed, screening *in-silico* drug actions on arcs against disease ones may be realized by assessing the consequence on the dynamics from the evaluation of marker states. To be feasible, this approach requires to automatically characterize actions from data and knowledge on drugs and to get reliable and complete description of network encompassing all the actions on arcs. The computational challenge for the drug design is the inverse problem of the therapy prediction, where the effects described by states of markers are known but the causes defined as actions must be discovered. Hence the issue is to infer the necessary actions on a diseased network in order to bring the dynamics back to the health state. This approach needs also to deduce the requested properties of the molecules to design and to compare them to actions of known molecules.

APPENDIX

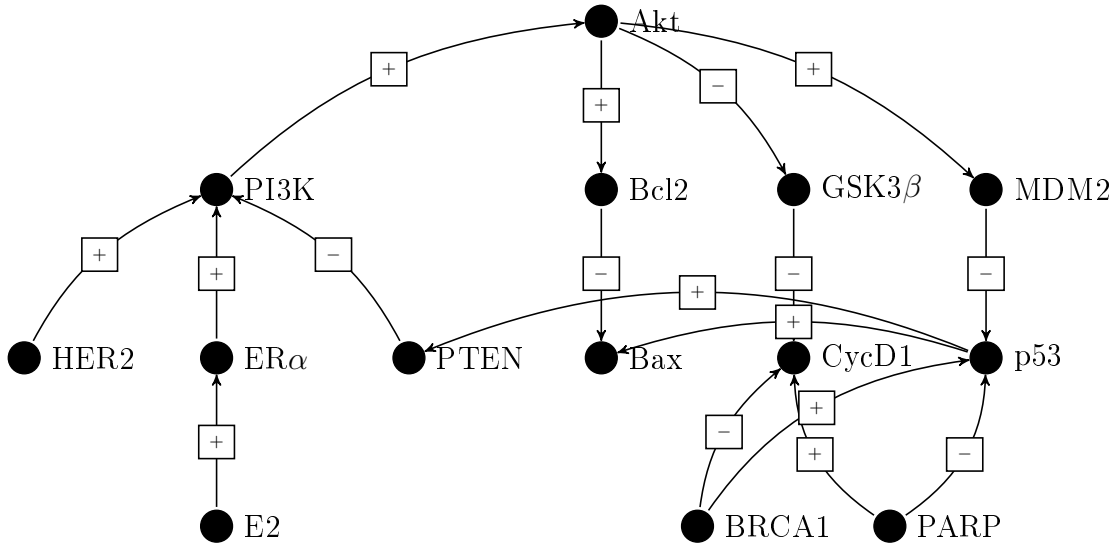

Figure 8: **Saturated graph of the breast cancer model** This graph represents all the interactions of healthy interaction graph and the interactions that can be added by strategies. Three interactions are added compared to the healthy interaction graph: the activation of PI3K by HER2 that occurs in HER2 positive breast cancer cells [22, 50] and the activation of PI3K by ER $\alpha$  that occurs in presence of E2 in ER-positive breast cancer cells [24, 42].

STRATEGY	ACTION	STRENGTH	ARC
Trastuzumab	Deletion	-1	HER2 $\overset{+}{\rightarrow}$ PI3K
Tamoxifen	Deletion	-1	E2 $\overset{+}{\rightarrow}$ ER $\alpha$
Olaparib	Deletion	-1	PARP $\overset{-}{\rightarrow}$ p53
			PARP $\overset{+}{\rightarrow}$ CycD1

Table 3: Drugs as strategies and associated actions

PROTEIN	LOGICAL FORMULA
E2	True
HER2	True
BRCA1	True
PARP	True
ER $\alpha$	E2
PI3K	$\neg$ PTEN $\wedge$ (ER $\alpha$ $\vee$ HER2)
Akt	PI3K
MDM2	Akt
GSK3 $\beta$	$\neg$ Akt
p53	$\neg$ MDM2 $\wedge$ (BRCA1 $\vee$ $\neg$ PARP)
PTEN	p53
Bax	$\neg$ Bcl2 $\wedge$ p53
Bcl2	Akt
CycD1	$\neg$ GSK3 $\beta$ $\vee$ ( $\neg$ BRCA1 $\wedge$ PARP)

Table 2: Logical rules underlying the activation of nodes. Both ER $\alpha$  and HER2 can activate PI3K signalling and PTEN terminates PI3K signalling.

STRATEGY	ACTION	STRENGTH	ARC
HER2	Addition	+1	HER2 $\xrightarrow{+}$ PI3K
ER	Addition	+1	ER $\alpha$ $\xrightarrow{+}$ PI3K
BRCA1	Deletion	-1	BRCA1 $\xrightarrow{+}$ p53 BRCA1 $\xrightarrow{-}$ CycD1

Table 4: Breast cancer subtypes as strategies and associated actions

CycD1	Bax	Physician score	Cancer score	Cell phenotype
0	0	25%	75%	Quiescent
0	1	100%	0%	Death
1	0	0%	100%	Division
1	1	25%	75%	Dormant

Table 5: Scores on the states of biomarkers

- [1] Wassim Abou-Jaoudé, Djomangan A. Ouattara, and Marcelle Kaufman. From structure to dynamics: frequency tuning in the p53-Mdm2 network i. logical approach. *Journal of theoretical biology*, 258(4):561–577, June 2009.
- [2] Samir K. Ballas. Defining the Phenotypes of Sickle Cell Disease. *Hemoglobin*, 35:511–519, 2011.
- [3] Albert-László Barabási. Network medicine—from obesity to the "diseaseome". *The New England journal of medicine*, 357(4):404–407, 2007.
- [4] Albert-László Barabási, Natali Gulbahce, and Joseph Loscalzo. Network medicine: a network-based approach to human disease. *Nature reviews. Genetics*, 12(1):56–68, 2011.
- [5] A Basu and S Haldar. The relationship between bcl2, bax and p53: consequences for cell cycle progression and cell death. *Molecular human reproduction*, 4(12):1099–1109, 1998.
- [6] Judith Campisi. Cancer and ageing: rival demons? *Nature reviews. Cancer*, 3(5):339–349, 2003.
- [7] A Carracedo and PP Pandolfi. The pten–pi3k pathway: of feedbacks and cross-talks. *Oncogene*, 27(41):5527–5541, 2008.
- [8] F Chang, JT Lee, PM Navolanic, LS Steelman, JG Shelton, WL Blalock, RA Franklin, and JA McCubrey. Involvement of pi3k/akt pathway in cell cycle progression, apoptosis, and neoplastic transformation: a target for cancer chemotherapy. *Leukemia*, 17(3):590–603, 2003.
- [9] Chafika Chettaoui, Franck Delaplace, Matthieu Manceny, and Michel Malo. Games network and application to pas system. *Biosystems*, 87(2):136–141, 2007.
- [10] Andrea Ciliberto, Béla Novak, and John J. Tyson. Steady states and oscillations in the p53/Mdm2 network. *Cell Cycle*, 4(3):488–493, March 2005.
- [11] Eric H Davidson. *The regulatory genome: gene regulatory networks in development and evolution*. Academic Press, 2010.

- [12] Franck Delaplace, Hanna Klaudel, and Amandine Cartier-Michaud. Discrete causal model view of biological networks. In *Proceedings of the 8th International Conference on Computational Methods in Systems Biology*, pages 4–13. ACM, 2010.
- [13] Chu-Xia Deng. Brca1: cell cycle checkpoint, genetic instability, dna damage response and cancer evolution. *Nucleic acids research*, 34(5):1416–1426, 2006.
- [14] Jeffrey A Engelman. Targeting pi3k signalling in cancer: opportunities, challenges and limitations. *Nature Reviews Cancer*, 9(8):550–562, 2009.
- [15] Stephen W Fesik. Promoting apoptosis as a strategy for cancer drug discovery. *Nature Reviews Cancer*, 5(11):876–885, 2005.
- [16] Richard Frank and Richard Hargreaves. Clinical biomarkers in drug discovery and development. *Nature Reviews Drug Discovery*, 2(7):566–580, 2003.
- [17] Milena Gasco, Shukri Shami, and Tim Crook. The p53 pathway in breast cancer. *Breast cancer research : BCR*, 4(2):70–76, 2002.
- [18] Geoffrey S. Ginsburg. Translational genomics: From discovery to clinical practice - chap. 22. In Huntington F. Willard and Ph.D.Geoffrey S. Ginsburg, editors, *Genomic and Personalized Medicine*, pages 262 – 274. Academic Press, New York, 2009.
- [19] Mika Gustafsson, Colm E Nestor, Huan Zhang, Albert-László Barabási, Sergio Baranzini, Sören Brunak, Kian Chung, Howard J Federoff, Anne-Claude Gavin, Richard R Meehan, Paola Picotti, Miguel Pujana, Nikolaus Rajewsky, Kenneth Smith, Peter J Sterk, Pablo Villoslada, and Mikael Benson. Modules, networks and systems medicine for understanding disease and aiding diagnosis. *Genome Medicine*, 6(10):82, 2014.
- [20] Douglas Hanahan and Robert a. Weinberg. Hallmarks of cancer: The next generation. *Cell*, 144(5):646–674, 2011.
- [21] Michaela J Higgins and José Baselga. Targeted therapies for breast cancer. *Journal of clinical investigation*, 121(10):3797–3803, 2011.

- [22] Nancy E Hynes and Heidi a Lane. ERBB receptors and cancer: the complexity of targeted inhibitors. *Nature reviews. Cancer*, 5(5):341–354, 2005.
- [23] Minoru Kanehisa and Susumu Goto. Kegg: kyoto encyclopedia of genes and genomes. *Nucleic acids research*, 28(1):27–30, 2000.
- [24] Young-Rae Lee, Jinny Park, Hong-Nu Yu, Jong-Suk Kim, Hyun Jo Youn, and Sung Hoo Jung. Up-regulation of pi3k/akt signaling by 17 $\beta$ -estradiol through activation of estrogen receptor- $\alpha$ , but not estrogen receptor- $\beta$ , and stimulates cell growth in breast cancer cells. *Biochemical and biophysical research communications*, 336(4):1221–1226, 2005.
- [25] Lindsey D. Mayo and David B. Donner. The PTEN, Mdm2, p53 tumor suppressor-oncoprotein network. *Trends in Biochemical Sciences*, 27(9):462–467, 2002.
- [26] Ron Milo, Shai Shen-Orr, Shalev Itzkovitz, Nadav Kashtan, Dmitri Chklovskii, and Uri Alon. Network motifs: simple building blocks of complex networks. *Science*, 298(5594):824–827, 2002.
- [27] Reza Mirnezami, Jeremy Nicholson, and Ara Darzi. Preparing for Precision Medicine. *New England Journal of Medicine*, 366:489–491, 2012.
- [28] Ute M Moll and Oleksi Petrenko. The mdm2-p53 interaction. *Molecular Cancer Research*, 1(14):1001–1008, 2003.
- [29] PB Mullan, JE Quinn, and DP Harkin. The role of brca1 in transcriptional regulation and cell cycle control. *Oncogene*, 25(43):5854–5863, 2006.
- [30] Elizabeth A Musgrove, C Elizabeth Caldon, Jane Barraclough, Andrew Stone, and Robert L Sutherland. Cyclin d as a therapeutic target in cancer. *Nature Reviews Cancer*, 11(8):558–572, 2011.
- [31] Diana Nguyen, Maria Zajac-Kaye, Larry Rubinstein, Donna Voeller, Joseph E Tomaszewski, Shivaani Kummur, Alice P Chen, Yves Pommier, James H Doroshow, and Sherry X Yang. Poly (adp-ribose) polymerase inhibition enhances p53-dependent and-independent dna damage responses induced by dna damaging agent. *Cell Cycle*, 10(23):4074–4082, 2011.

- [32] Martin J Osborne and Ariel Rubinstein. *A course in game theory*. MIT press, 1994.
- [33] Martin Oti, Berend Snel, Martijn A Huynen, and Han G Brunner. Predicting disease genes using protein–protein interactions. *Journal of medical genetics*, 43(8):691–698, 2006.
- [34] Stéphane Le Roux, Pierre Lescanne, and René Vestergaard. Conversion/preference games. *CoRR*, abs/0811.0071, 2008.
- [35] Charles Sawyers. Targeted cancer therapy. *Nature*, 432(7015):294–297, 2004.
- [36] Eric E Schadt. Molecular networks as sensors and drivers of common human diseases. *Nature*, 461(September):218–223, 2009.
- [37] Paola Sebastiani, Marco F Ramoni, Vikki Nolan, Clinton T Baldwin, and H Martin. Genetic dissection and prognostic modeling of overt stroke in sickle cell anemia. *Nature Genetics*, 37(4):435–440, 2010.
- [38] Reuben J Shaw and Lewis C Cantley. Ras, pi (3) k and mtor signalling controls tumour cell growth. *Nature*, 441(7092):424–430, 2006.
- [39] Charles J Sherr and Frank McCormick. The rb and p53 pathways in cancer. *Cancer cell*, 2(2):103–112, 2002.
- [40] M. Spiliotaki, H. Markomanolaki, G. Kallergi, M. a. Papadaki, V. Georgoulas, D. Mavroudis, and S. Agelaki. Evaluation of proliferation and apoptosis markers in circulating tumor cells (CTCs) of women with early breast cancer who are candidates for tumor dormancy. *Cancer Research*, 72(8 Supplement):2397–2397, 2012.
- [41] V. Stambolic, D. MacPherson, D. Sas, Y. Lin, B. Snow, Y. Jang, S. Benchimol, and T. W. Mak. Regulation of PTEN transcription by p53. *Molecular Cell*, 8(2):317–325, 2001.
- [42] Mei Sun, June E Paciga, Richard I Feldman, Zeng-qiang Yuan, Domenico Coppola, You Yong Lu, Sue A Shelley, Santo V Nicosia, and Jin Q Cheng. Phosphatidylinositol-3-oh kinase (pi3k)/akt2, activated in breast cancer, regulates and is induced by estrogen receptor  $\alpha$  ( $er\alpha$ ) via interaction between  $er\alpha$  and pi3k. *Cancer research*, 61(16):5985–5991, 2001.

- [43] R. Thomas and D. Thieffry. Dynamical behaviours of regulatory networks - II . immunity control in bactériophage lambda. *Bulletin of Mathematical Biology*, 57(2):277–297, 1995.
- [44] René Thomas. Boolean formalization of genetic control circuits. *Journal of theoretical biology*, 42(3):563–585, 1973.
- [45] Miyashita Toshiyuki and John C Reed. Tumor suppressor p53 is a direct transcriptional activator of the human bax gene. *Cell*, 80(2):293–299, 1995.
- [46] M Vidal and Me Cusick. Interactome Networks and Human Disease. *Cell*, 144(6):986–998, 2011.
- [47] Timothy H Ward, Jeffrey Cummings, E Dean, Alastair Greystoke, Jian-Mei Hou, A Backen, M Ranson, and Caroline Dive. Biomarkers of apoptosis. *British journal of cancer*, 99(6):841–846, 2008.
- [48] Piri L Welcsh and Mary-Claire King. Brca1 and brca2 and the genetics of breast and ovarian cancer. *Human molecular genetics*, 10(7):705–713, 2001.
- [49] Xiaoling Xu, Wenhui Qiao, Steven P Linke, Liu Cao, Wen-Mei Li, Priscilla A Furth, Curtis C Harris, and Chu-Xia Deng. Genetic interactions between tumor suppressors brca1 and p53 in apoptosis, cell cycle and tumorigenesis. *Nature genetics*, 28(3):266–271, 2001.
- [50] Y Yarden and M X Sliwkowski. Untangling the ErbB signalling network. *Nature reviews. Molecular cell biology*, 2(2):127–137, 2001.
- [51] Quan Zhong, Nicolas Simonis, Qian-Ru Li, Benoit Charloteaux, Fabien Heuze, Niels Klitgord, Stanley Tam, Haiyuan Yu, Kavitha Venkatesan, Danny Mou, Venus Swearingen, Muhammed a Yildirim, Han Yan, Amélie Dricot, David Szeto, Chenwei Lin, Tong Hao, Changyu Fan, Stuart Milstein, Denis Dupuy, Robert Brasseur, David E Hill, Michael E Cusick, and Marc Vidal. Edgetic perturbation models of human inherited disorders. *Molecular systems biology*, 5(321):321, 2009.