

**This document must be cited according  
to its final version which is published in a conference as:**

**V.Grelet, P. Dufour, M. Nadri, V.Lemort, T. Reiche,  
"Modeling and control of Rankine based waste heat recovery systems  
for heavy duty trucks",  
IFAC Advanced Control of Chemical Processes (ADCHEM),  
Whistler, British Columbia, Canada, pp. 569-574, June 7-10, 2015.**

**You downloaded this document from the  
CNRS open archives server, on the webpages of Pascal Dufour:  
<http://hal.archives-ouvertes.fr/DUFOUR-PASCAL-C-3926-2008>**

# Modeling and control of Rankine based waste heat recovery systems for heavy duty trucks

V. Grelet<sup>1,2,3</sup>, P. Dufour<sup>2\*</sup>,  
M. Nadri<sup>2</sup>, T. Reiche<sup>1</sup>, V. Lemort<sup>3</sup>

<sup>1</sup>Volvo Trucks Global Trucks Technology Advanced Technology and Research, F-69800, Saint Priest, France

<sup>2</sup>University of Lyon, F-69622, Lyon, France – University Lyon 1, Villeurbanne, France – CNRS, UMR 5007, LAGEP

<sup>3</sup>University of Liège, Campus du Sart Tilman Bât. B49 B4000 Liège, Belgium

\*Corresponding author. Tel +33472431878. E-mail address: [dufour@lagep.univ-lyon1.fr](mailto:dufour@lagep.univ-lyon1.fr)

---

**Abstract:** This paper presents a control oriented model development for waste heat recovery Rankine based control systems in heavy duty trucks. Waste heat recovery systems, such as Rankine cycle, are promising solutions to improve the fuel efficiency of heavy duty engines. Due to the highly transient operating conditions, improving the control strategy of those systems is an important step to their integration into a vehicle. The system considered here is recovering heat from both EGR and exhaust in a serial arrangement and use a mixture of water and ethanol as working fluid. The paper focuses on a comparison of a classical PID controller which is the state of the art in the automotive industry and a nonlinear model based controller in a simulation environment. The nonlinear model based controller shows better performance than the PID one and ensures safe operation of the system.

**Keywords:** Waste Heat Recovery, Modeling, Control, PID.

---

## 1. INTRODUCTION

The idea of recovering waste heat and utilize it as another form of energy is not new. Most of the actual power plants use the principle of co or even tri-generation. In the automotive industry, the most applied form of waste heat recovery system is the turbocharger which converts the waste heat into aerualic energy by compressing the fresh air via an exhaust driven turbine. Driven by future emissions legislations and increase in fuel prices, engine gas heat recovering has recently attracted a lot of interest. In the past few years, a high number of studies have shown the interest of energy recovery Rankine based systems for heavy duty trucks engine compounding [Sprouse et al. (2013), Espinosa (2011)]. Recent studies have brought a significant potential for such a system in a Heavy Duty (HD) vehicle which can lead to a decrease in fuel consumption of about 5% and reduce engine emissions. Yet many challenges have to be faced before the vehicle integration. The first challenge deals with the correct choice of fluids and system architecture [Mago et al. (2007), Grelet et al. (2014)] and shows that system simulation is a critical part of the development work. The use of water-alcohol mixture can bring some advantages in the power recuperation and overcome both disadvantages of these fluids: high freezing temperature of water and flammability of alcohol [Latz et al. (2012)]. In those blends, Water Ethanol is quite promising and is compliant with vehicle integration where both pure fluids are not. In comparison with stationary plant, where the system is designed to run at its nominal point, the vehicle integration has to face a second challenge such as the limited cooling capacity and the highly transient behaviour of the heat sources. To deal with that, an effective control strategy is really important to maximize power recuperation and ensure

a safe operation of the system. Although many papers concerning Rankine components and system optimization for mobile application can be found in the literature [Seher et al. (2012), Mavridou et al. (2010)], only few of them deal with control development and operating strategy improvement [Perez et al. (2013), Willems et al. (2012)]. One key variable to control is the working fluid temperature at the evaporator outlet / expander inlet since this temperature has a big impact on system performance [Quoilin et al. (2011)]. In a system perspective, it has to be as close as possible to the vapor saturation line to increase the system efficiency. An effective control of this temperature will allow to have longer recovery period by increasing the time where the expander is fed with vapour. This criterion can be achieved by reducing the standard deviation to the set point (SP). This paper is organized as follows. Section 2 presents the principle and the studied system. Section 3 approaches the modelling methodology and the resulting partial differential equation (PDE) system. Section 4 shows the two implemented controllers when section 5 compares their performances.

## 2. PRINCIPLES AND STUDIED SYSTEM

All the variables used in the following are explicitly defined in tables 2, 3 and 4 of the appendix.

### 2.1. Rankine Process

Rankine cycle is a widely used power generation cycle to turn heat into mechanical or electrical power. First the working fluid is pumped from a tank at the condensing pressure to the evaporator at the evaporating pressure. Then the pressurized working fluid is pre-heated, vaporized and superheated in one or several heat exchangers (HEX), also known as boilers. These HEX are linked to the heat source. The superheated vapor expands from evaporating pressure to

condensing pressure in an expansion device converting the pressure and enthalpy drop into mechanical work. Finally the expanded vapour condenses through a condenser releasing heat into the heat sink (e.g. ambient air) and returns to the working fluid reservoir. In this process the changes of states in both the pump and the expander are irreversible and increase the fluid entropy to a certain extent.

## 2.2. Studied System

The Waste Heat Recovery System (WHRS) is compounded on a turbocharged 6 cylinder 11L 320kW HD engine using exhaust gas recirculation (EGR) and a selective catalyst reduction system (SCR) to reduce the NO<sub>x</sub> emissions. The studied Rankine cycle is recovering heat from both EGR and Exhaust applying a serial configuration of two heat exchangers. Figure 1 shows a schematic of the studied system. The mass flow rate through the two boilers is controlled by the pump speed. The expansion machine is a turbine, which has a higher power density than volumetric expanders [Seher et al. (2012), Lemort et al. (2013)]. The working fluid is then condensed through an indirect condenser fed by coolant. Moreover the cycle is equipped with two bypass valves one located in the exhaust stream to control the amount of energy introduced in the system and a second in front of the expansion device to prevent liquid to enter in the turbine and avoid blade erosion caused by liquid droplets into a high speed rotor.

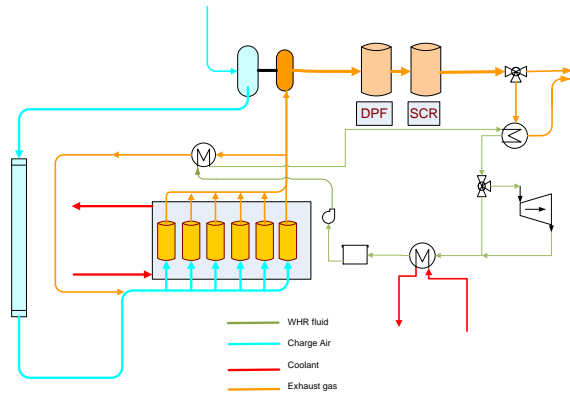

Fig 1 Studied system

The chosen working fluid is a predefined mixture of Ethanol and Water which gives the best compromise concerning performance and reduced flammability.

## 3. HEAT EXCHANGER CONTROL ORIENTED MODELING

The system dynamic is controlled by the HEX behaviour (i.e. evaporators and condenser) and models of these components are developed to dynamically predict temperature and enthalpy of transfer and working fluid at the outlet of each boiler. This is critical when coming to control design to ensure a safe operation and a proper operation of the EGR function. Safe operation means that the fluid is completely vaporized when entering the turbine in order not to destroy it. For the EGR, the aim is to have low gas temperature at the

outlet of the boiler, in order not to disturb the emissions control strategy and the internal combustion process.

### 3.1. Model Assumptions

Several assumptions have been done to simplify the problem in a great extent. They are usually admitted when coming to heat exchanger modelling [Feru et al. (2013), Vaja (2009)]:

- The transfer fluid is always considered in single phase i.e. no condensation in the EGR/exhaust gases is taken into account.
- The conductive heat fluxes are neglected since the predominant phenomenon is the convection.
- The pressure drops on each fluids side (transfer and working fluids) are not considered.
- Both boilers are represented by a straight pipe in pipe counterflow heat exchanger, similarly to Vaja (2009), divided into  $n$  lumped sub-volumes in the longitudinal direction.
- Fluid properties are evaluated at the outlet of each sub-volume i.e. linear profile is considered between inlet and outlet of each node.
- Pressure dynamics is neglected since its time scale is very small considered to the HEX time scale.
- Working fluid mass flow rate is supposed constant along the heat exchanger.

### 3.2. Governing Equations

Since the mass is assumed constant the continuity equation is neglected and the model is only based on the energy conservation for the working fluid (1), the gas (2) and the energy balance at the internal (3) and external wall (4).

$$\frac{\partial \dot{m}_{wf} h_{wf}}{\partial z} - \dot{Q}_{conv\ wf\ int} = \rho_{wf} V_{wf} \frac{\partial h_{wf}}{\partial t}. \quad (1)$$

$$\frac{\partial \dot{m}_g c_{p,g}(T_g)}{\partial z} - \dot{Q}_{conv\ g\ int} - \dot{Q}_{conv\ g\ ext} = \rho_g V_g c_{p,g}(T_g) \frac{\partial T_g}{\partial t}. \quad (2)$$

$$\dot{Q}_{conv\ g\ int} + \dot{Q}_{conv\ wf\ int} = \rho_{wall} V_{wall\ int} c_{p,wall} \frac{\partial T_{wall\ int}}{\partial t}. \quad (3)$$

$$\dot{Q}_{conv\ g\ ext} + \dot{Q}_{conv\ amb\ ext} = \rho_{wall} V_{wall\ ext} c_{p,wall} \frac{\partial T_{wall\ ext}}{\partial t}, \quad (4)$$

$$\text{with } \dot{Q}_{conv\ jk} = \alpha_j A_{exch\ jk} (T_j - T_{wall\ k}), \quad (5)$$

where  $j = g, wf, amb$  and  $k = int, ext$ .

Furthermore, to complete the system we need boundary and initial conditions. Time-dependent boundary conditions are used in  $z=0$  and  $z=L$ :

$$\left. \begin{aligned} \dot{m}_{wf}(t, 0) &= \dot{m}_{wf0}(t), \\ \dot{m}_g(t, L) &= \dot{m}_{g1}(t), \end{aligned} \right| \begin{aligned} h_{wf}(t, 0) &= h_{wf0}(t), \\ T_g(t, L) &= T_{gL}(t). \end{aligned}$$

The initial conditions for the gas and wall temperatures and working fluid enthalpy are given by:

$$\left. \begin{aligned} T_g(0, z) &= T_{g\ init}(z), \\ h_{wf}(0, z) &= h_{wf\ init}(z). \end{aligned} \right| \begin{aligned} T_{wall\ int}(0, z) &= T_{wall\ int\ init}(z), \\ T_{wall\ ext}(0, z) &= T_{wall\ ext\ init}(z), \end{aligned}$$

The manipulated variable (MV) is the working fluid mass flow  $\dot{m}_{wf0}(t)$ , whereas the controlled variable (CV) is the working fluid enthalpy  $h_{wf}(t, L)$ . However the enthalpy is impossible to measure directly we have to use pressure and temperature measurement to compute it.

### 3.3. Heat Transfer

To model the convection from the transfer fluid to the pipe walls and from the internal pipe to the working fluid a heat transfer coefficient ( $\alpha$ ) is needed. The convection from a

boundary to a moving fluid is usually represented by the dimensionless Nusselt number ( $Nu$ ) which is the ratio of convective to conductive heat transfer.

$$Nu = \frac{\alpha * l}{\lambda}, \quad (6)$$

where  $l$  here represents a characteristic length and is in this case the hydraulic diameter. Numerous correlations to approach this number can be found in the literature and are usually derived from experiments, see for example Thome (2010). Those correlations depend on the flow regime, the number of phases and the geometry studied. In single phase, the following correlation is implemented:

$$Nu = A Re^n Pr^m, \quad (7)$$

where  $A$  is a constant  $Re$  and  $Pr$  are dimensionless number (respectively Reynolds and Prandtl number). By developing these two numbers (7) becomes:

$$Nu = A \left( \frac{4\dot{m}}{\pi d_h \mu} \right)^n \left( \frac{c_p \mu}{\lambda} \right)^m. \quad (8)$$

Assuming the viscosity ( $\mu$ ) the specific heat ( $c_p$ ), the heat conductivity ( $\lambda$ ) and the characteristic length ( $l$ ) constant in single phase region for the working fluid and the gas we get:

$$\alpha_{liq\ wf} = \alpha_{ref\ liq\ wf} \dot{m}_{wf}^{n_{liq\ wf}}, \quad (9a)$$

$$\alpha_{vap\ wf} = \alpha_{ref\ vap\ wf} \dot{m}_{wf}^{n_{vap\ wf}}, \quad (9b)$$

$$\alpha_g = \alpha_{ref\ g} \dot{m}_g^{n_g}, \quad (9c)$$

Where the constant  $\alpha_{ref}$  and the exponent  $n$  have to be identified in liquid and vapor region for the working fluid and in single phase for the gas. In the two phase region, a more complex correlation (10) is used to enhance the single phase heat transfer coefficient [Kleiber and Joh (2010)].

$$\alpha_{2\phi\ wf} = \alpha_{liq\ wf} \left\{ (1-q)^{0.01} \left[ (1-q) + 1.2q^{0.4} \frac{\rho_{wf\ liq}^{0.37}}{\rho_{wf\ vap}} \right]^{-2.2} + \alpha_{wf\ vap} \left[ \frac{\alpha_{wf\ vap}}{\alpha_{wf\ liq}} (1 + 8(1-q)^{0.7} \frac{\rho_{wf\ liq}^{0.67}}{\rho_{wf\ vap}}) \right]^{-2} \right\}^{-0.5}. \quad (10)$$

This correlation corresponds to a tube arrangement and is practical since it creates continuity between single and two phase heat transfer coefficients and does not need transport properties such as viscosity or heat conductivity.

### 3.4. Working Fluid Properties

Similarly to Kleiber and Joh (2010), the working fluid properties are approximated using mathematical description. This allows not to rely on thermochemical database such as Lemmon et al. (2011) and creates continuity in derivative terms during the single / two phase transition. The fluid properties are only function of pressure and enthalpy.

- Temperature model:

$$T_{wf} = \begin{cases} \alpha_{Tliq} h_{wf}^2 + b_{Tliq} h_{wf} + c_{Tliq} & \text{if } h_{wf} \leq h_{sat\ liq} \\ T_{sat\ liq} + q(T_{sat\ vap} - T_{sat\ liq}) & \text{if } h_{sat\ liq} < h_{wf} < h_{sat\ vap} \\ \alpha_{Tvap} h_{wf}^2 + b_{Tvap} h_{wf} + c_{Tvap} & \text{if } h_{wf} \geq h_{sat\ vap} \end{cases}, \quad (11)$$

where  $a$ ,  $b$ , and  $c$  are first order polynomial expressions function of pressure and  $q$  is the fluid quality defined as the quantity of vapor present in the two phase flow.

$$q = \frac{h_{wf} - h_{sat\ liq}}{h_{sat\ vap} - h_{sat\ liq}}. \quad (12)$$

The saturation temperature ( $T_{sat}$ ) is approximated with the Wagner equation with adapted coefficient for liquid and vapor saturation [Kleiber and Joh (2010)] and allows to make the transition between each phase.

- Density model:

$$\rho_{wf} = \begin{cases} \alpha_{dliq} h_{wf}^2 + b_{dliq} h_{wf} + c_{dliq} & \text{if } h_{wf} \leq h_{sat\ liq} \\ \frac{1}{\alpha_{d2\phi} h_{wf} + b_{d2\phi}} & \text{if } h_{sat\ liq} < h_{wf} < h_{sat\ vap} \\ \alpha_{dvap} h_{wf}^2 + b_{dvap} h_{wf} + c_{dvap} & \text{if } h_{wf} \geq h_{sat\ vap} \end{cases}. \quad (13)$$

In single phase ( $liq$  and  $vap$ ) the coefficient  $a$ ,  $b$ , and  $c$ , are evaluated thanks to third order polynomial function of pressure similar to:

$$\alpha_d = a_{d3} P_{wf}^3 + a_{d2} P_{wf}^2 + a_{d1} P_{wf} + a_{d0}. \quad (14)$$

In two-phase region  $a_{d2\phi}$  and  $b_{d2\phi}$  are approximated with:

$$a_{d2\phi} = \frac{1}{a_{d2\phi1} P_{wf} + a_{d2\phi0}}, \quad (15a)$$

$$b_{d2\phi} = \frac{1}{b_{d2\phi1} P_{wf} + b_{d2\phi0}}. \quad (15b)$$

All coefficients are evaluated by fitting routines in Matlab using REFPROP as thermodynamic properties database [Lemmon et al. (2011)].

### 3.5. Discretization

To implement such a model, we now have to discretize the continuous heat exchanger model with respect to space based on finite differences method. The HEX is split into  $n$  longitudinal cell where a backward Euler scheme in space is applied. The system of equations defining the response of the  $i$ th cell for transfer fluid, pipe and working fluid can be represented under the following formalism.

$$\dot{x} = f(x, u), \quad (16)$$

where

$$u = [\dot{m}_{wf0} \ P_{wf0} \ h_{wf0} \ \dot{m}_{gL} \ T_{gL}]. \quad (17)$$

The vector  $x$  contains the only MV ( $\dot{m}_{wf0}$ ) and four inputs disturbances: inlet gas mass flow and temperature ( $\dot{m}_{gL}$ ) and ( $T_{gL}$ ) and inlet working fluid pressure and enthalpy ( $P_{wf0}$ ) and ( $h_{wf0}$ ).

And

$$x_i = [h_{wf\ i} \ T_{wall\ int\ i} \ T_{g\ i} \ T_{wall\ ext\ i}], \quad (18a)$$

$$f_i(x, u) = \begin{bmatrix} \frac{(\dot{m}_{wf} (h_{wf\ i-1} - h_{wf\ i}) - \alpha_{wf} A_{exch\ wf} (T_{wf\ i} - T_{wall\ int\ i}))}{\rho_{wf\ i} V_{wf}} \\ \frac{\alpha_{wf} A_{exch\ wf} (T_{wf\ i} - T_{wall\ int\ i}) + \alpha_g A_{exch\ g\ int} (T_{g\ i} - T_{wall\ int\ i})}{\rho_{wall} c_{p\ wall} V_{wall\ int}} \\ \frac{(\dot{m}_g c_{p\ g} (T_{g\ i-1} - T_{g\ i}) - \alpha_g A_{exch\ g\ int} (T_{g\ i} - T_{wall\ int\ i}) - \alpha_g A_{exch\ g\ ext} (T_{g\ i} - T_{wall\ ext\ i}))}{\rho_g V_g c_{p\ g} (T_g)} \\ \frac{\alpha_{amb} A_{exch\ amb} (T_{amb\ i} - T_{wall\ ext\ i}) + \alpha_g A_{exch\ g\ ext} (T_{g\ i} - T_{wall\ ext\ i})}{\rho_{wall} c_{p\ wall} V_{wall\ ext}} \end{bmatrix}. \quad (18b)$$

## 4. CONTROL DEVELOPMENT

In this paper we focus on the temperature control with only regards to power generation. Our goal here is to improve the temperature stability around a given set point. For that we can manipulate the working fluid mass flow to regulate the working fluid enthalpy (or temperature) at the outlet of the exhaust boiler. Due to time issue, at the moment where this paper is written, no experimental tests of the control system are possible. The validation is based on the representative simulation model. The comparison is done on the tracking error either on a step load change or on a complete driving cycle. On each case, we start from the same equilibrium.

### 4.1. PI Controller

The main problem when considering PI or PID control structure is that identification for heat exchangers is very sensitive to the inputs considered [Perez et al. (2013), Horst et al. (2013)]. This is well described when considering

several operating points. Most of the results on PID tuning are reducing the process to a first order plus time delay (FOPTD) transfer function [Skogestad (2003), Madhuranthakam et al. (2009)]. The dynamic relation between the variations of WF mass flow and the temperature is:

$$\frac{\Delta T_{wfL}(s)}{\Delta \dot{m}_{wf0}(s)} = \frac{G}{1 + \tau s} e^{-Ds}. \quad (19)$$

For the identification a pseudo random binary sequence (PRBS) is the same for all operating points. As it can be seen in figure 2, this model structure is confirmed by comparing results of the reference model and an identified FOPTD around an operating point since on the worst point the agreement is around 94%. Figure 3 shows the FOPTD parameters for several inputs disturbance. For convenience they are represented versus the total heat flow rate entering:

$$\dot{Q}_{tot} = c_{pg}(T^*) (\dot{m}_{egr}(T_{egr\ in} - T_{wf0}) + \dot{m}_{exh}(T_{exh\ in} - T_{wf\ sat})). \quad (20)$$

where  $T^* = \frac{T_{egr\ in} + T_{exh\ in}}{2}$ .

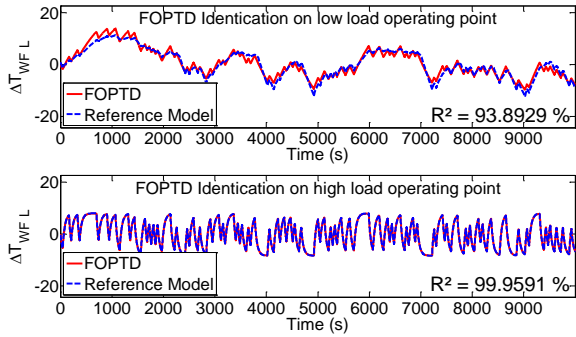

Fig 2 FOPTD model identification validation

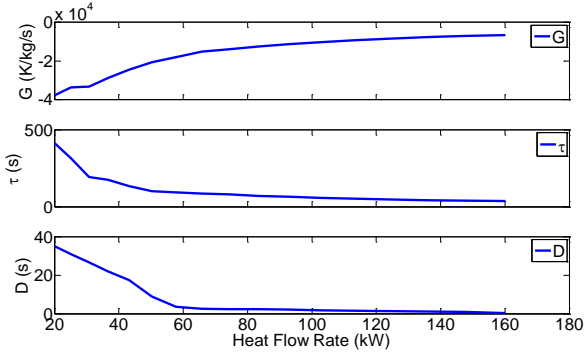

Fig 3 FOPTD model parameter

FOPTD parameters are evaluated on twenty different engine operating points, which correspond to the input disturbances, representing the overall engine map. As it can be seen below, the FOPTD parameters change a lot, according to the nonlinearity of the model developed in section 3. To improve the system control several PID tuning methods are compared to reduce both the tracking error and the control effort [Skogestad (2003), Madhuranthakam et al. (2008)]. Moreover, to obtain better results on a realistic driving cycle, gains are scheduled as a function of the working fluid mass flow rate entering in the system. The scheduling of each gain is realized by interpolating Kp, Ti and Td according to the working fluid mass flow feedback signal. A normal scheduling would be to select the appropriate gain in function of the operating point but schedule it as a function of the

manipulated variable is here preferred to take into account the thermal inertia of the system [Rasmussen and Alleyne (2010)]. Comparison on a step load change for several PID tuning method is shown in table 1. On two criteria: the integrated absolute error (IAE) and the total variation (TV) which are defined as:

$$IAE = \int_0^{\infty} |CV(t) - SP(t)| dt. \quad (21)$$

$$TV = \int_0^{\infty} \frac{dMV(t)}{dt} dt. \quad (22)$$

The method proposed by Madhuranthakam et al. (2008) is minimizing the IAE with the highest TV, i.e. the control effort is more important but still acceptable. The IMC and Tyreus-Luyben tuning methods seem to be conservative and too slow since they present the highest IAE. Figure 4 shows the tracking error versus time for the five tuning methods.

Tuning Method	IAE	TV
Ziegler Nichols in Closed Loop	84.6325	0.0065
Tyreus-Luyben [Skogestad (2003)]	743.1427	0.0053
IMC	940.3763	0.0064
SIMC [Skogestad (2003)]	208.5099	0.0047
Madhuranthakam et al. [Madhuranthakam et al. (2008)]	48.6754	0.0204

Table 1 PID tuning method comparison

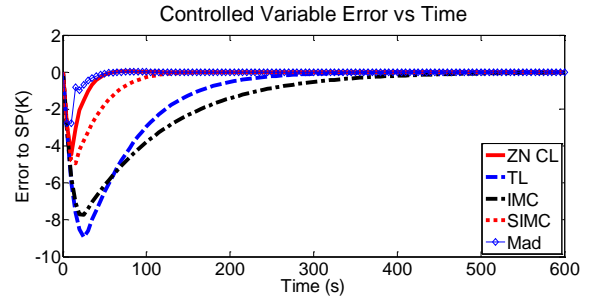

Fig 4 Tracking error comparison

The PID tuning of Madhuranthakam et al. (2008) is now used.

#### 4.2. Nonlinear model inversion

Despite of their very good agreement, the FOPTD could not be inverted to be used as controller since they do not take account of the disturbances and therefore every correction action would only be done through a feedback on the manipulated variable. In order to improve the performance of the classical "PID" controller we use the inverse of the system model (16-18) as feedforward to compute the first part of the MV corresponding to the desired set point (Fig. 5). Details of nonlinear inversion are approached and detailed in [Perez et al. (2013)]. To simplify the model inversion, the heat transfer coefficient for the WF is assumed constant in liquid and vapor phase.

$$\alpha_{wf} = \alpha_{wf\ ref} \frac{(\dot{m}_{wf\ max} + \dot{m}_{wf\ min})^n}{2}, \quad (23)$$

with maximum and minimum mass flow set as the mass flow corresponding to maximum and minimum WF pump speed:

$$\dot{m}_{wf0} = \rho_{wf0} \frac{N}{60} Cc_{pump}. \quad (24)$$

As the WF mass flow is considered homogenous in the entire heat exchanger it can be computed from the system (16).

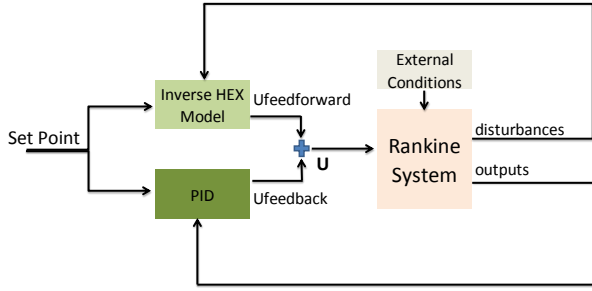

Fig 5 New control structure proposed

## 5. COMPARISON OF CONTROLLERS PERFORMANCES

This two proposed control strategies are evaluated on a validated Rankine model (at the time of writing the experimental set up was not available). Gases data (exhaust and EGR) are coming from an 11L long haul truck on a highway driving cycle (Fig. 6). For the other perturbations, namely called  $h_{wf0}$  and  $P_{wf0}$  in (19), the EGR boiler inlet WF enthalpy is kept constant whereas the inlet WF pressure depends on the expansion turbine inlet conditions. Sensors and actuators dynamics are represented by first order models where time constant are fitted thanks to manufacturer data.

As previously said, the controlled variable in the model is the WF enthalpy but as this one is not physically measurable and for convenience we track the WF temperature at the second boiler outlet. In order to well assess the performance, the set point changes during the simulation.

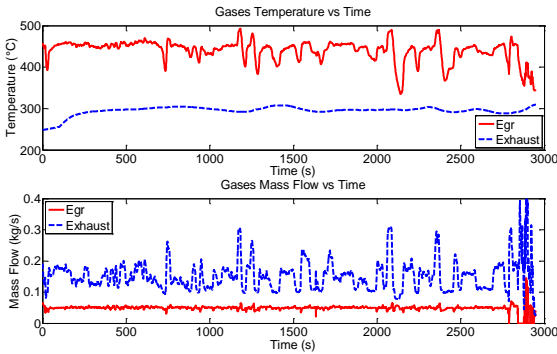

Fig 6 Input disturbances

Figure 7 and 8 show comparison of the two implemented control strategies: the PID based on Madhuranthakam et al. (2008) and the nonlinear control presented in 4.2. Except at the beginning, where the PID is not handling the initial SP variation and the large change in disturbances appearing around 30s, it keeps the error within  $\pm 10K$ , which could be acceptable when considering a volumetric expander, which are less sensitive to liquid droplets. Here a kinetic expansion machine is used and the temperature has to be as close as possible to the set point, which is better achieved by the nonlinear controller: the error remains in  $\pm 3K$ . The control efforts seem similar but are slightly different (PID presents a delay compared to nonlinear controller).

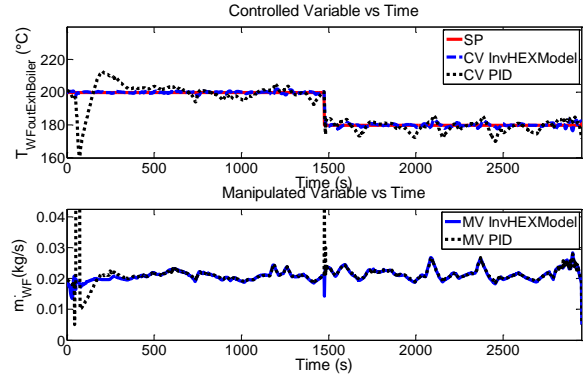

Fig 7 Controllers performance comparison

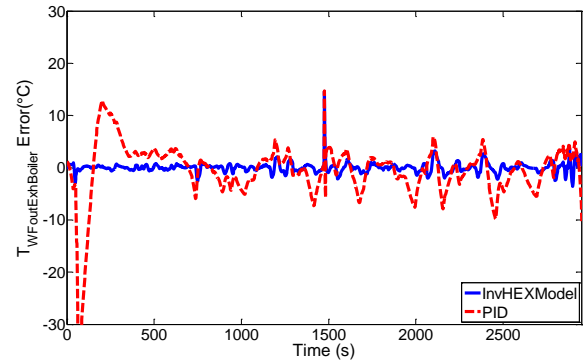

Fig 8 Tracking error comparison

## 6. CONCLUSION

This paper reports control strategy development for waste heat recovery Rankine based system used on heavy duty engines. Comparison of both controllers shows a better accuracy for the inverse HEX model when comparing the tracking error. The objective to stabilize as close as possible the temperature around a given set point is achieved by using this strategy. We conclude that the nonlinear controller leads to the best performances, at the cost of developing an accurate first principle nonlinear model with all known parameters, which underline the problem of identification. Yet it still needs to be validated on test bench level to see the robustness with respect to modelling errors and parameters mismatch. However the model is compliant with classical control unit used in the automotive industry since the computational needs is low. Future work will focus on experimental validation and optimal control strategy.

## ACKNOWLEDGMENT

This PhD thesis is collaboration between UCBL1, ULg and Volvo Trucks which is gratefully acknowledged for the funding. The French ministry of higher education and research for the financial support of the CIFRE PhD thesis 2012/549 is also acknowledged.



## REFERENCE

- Espinosa, N. (2011). "Contribution to the Study of Waste Heat Recovery Systems on Commercial Truck Diesel Engines". PhD Thesis University of Liege and National Polytechnic Institute of Lorraine.
- Feru, E. Kupper, F. Rojer, C. Seykens, X. Scappin, F. Willems, F. Smits, J. De Jager, B. Steinbuch, M. (2013). "Experimental Validation of a Dynamic Waste Heat Recovery System Model for Control Purposes". *SAE Technical Paper*, 2013-01-1647.
- Grelet, V. Reiche, T. Guillaume, L. Lemort, V. (2014). "Optimal WHR Rankine based for Heavy Duty Application". *FISITA Conference*, NL, F2014-CET-151
- Horst, T. Rottengruber, H. Seifert, M. Ringler, J. (2013). "Dynamic Heat Exchanger Model for Performance Prediction and Control System Design of Automotive Waste Heat recovery Systems". *Applied Energy*, Vol 105, 293-303.
- Kleiber, M. Joh, R. (2010). *VDI-Gesellschaft Verfahrenstechnik und Chemieingenieurwesen. VDI Heat Atlas Second Edition*. Part D Thermophysical properties. Springer Berlin Germany.
- Latz, G. Andersson, S. Munch, K. (2012). "Comparison of Working Fluids in Both Subcritical and Supercritical Rankine Cycles for Waste Heat Recover Systems in Heavy Duty Vehicles". *SAE Technical Papers*, 2012-01-1200.
- Lemmon, E.W. Huber, M.L. McLinden, M.O. (2011). REFPROP Nist Standard Reference Database 23 (Version 9.0), Thermophysical Properties Division, National Institute of Standards and Technology, Boulder, CO.
- Lemort, V. Guillaume, L. Legros, A. Declay, S. Quoilin, S. (2013). "A Comparison of Piston, Screw and Scroll Expanders for Small Scale Rankine Cycle Systems". *Proceedings of the 3rd International Conference on Microgeneration and Related Technologies*.
- Madhuranthakam, C.R. Elkamel, A. Budman, H. (2008). "Optimal tuning of PID controllers for FOTPD, SOPTD and SOPTD with lead processes". *Chemical Engineering and Processing*, vol 47, 251-264.
- Mago, P. Chamra, L. Somayajii. (2007). "Performance Analysis of Different Working Fluids for Use in Organic Rankine Cycles". *Journal of Power and Energy*, vol 221, 255-263.
- Mavridou, S. Mavropoulos, G. Bouris, D. Hountalas, D. Bergeles, G. (2010). "Comparative Design Study of a Diesel Exhaust Gas Heat Exchanger for Truck Applications with Conventional and State of the Art Heat Transfer Enhancements". *Applied Thermal Engineering*, vol 30, 935-947
- Peralez, J. Tona, P. Lepreux, O. Sciarretta, A. Voise, L. Dufour, P. Nadri, M. (2013). "Improving the Control Performance of an Organic Rankine Cycle System for Waste Heat Recovery from a Heavy Duty Diesel Engine using a Model Based Approach". *IEEE Conference on Decision and Control (CDC)*, pp 6830-6836.
- Quoilin, S. Aumann, R. Grill, A. Schuster, A. Lemort, V. (2011). "Dynamic Modeling and Optimal Control Strategy of Waste Heat Recovery Organic rankine Cycles". *Applied Energy*, vol 88, 2183-2190.
- Rasmussen, B.P. and Alleyne, A.G. (2010). Gain Scheduled Control of an Air Conditioning System Using the Youla Parameterization. *IEEE Transactions on Control Systems Technology*, 18(5), 1216-1225.
- Seher, D. Lengenfelder, T. Gerhardt, J. Eisenmenger, N. Hackner, M. Krinn, I. (2012). "Waste Heat recovery for Commercial Vehicles with a Rankine Process". *21st Aachen Colloquium Automobile and Engine Technology*.
- Skogestad, S. (2003). "Simple analytical rules for model reduction and PID controller tuning". *Journal of Process and Control*, vol 13, 291-309.
- Sprouse, C. Depcik, C. (2013). "Review of Organic Rankine Cycles for Internal Combustion Engine Exhaust Waste Heat Recovery". *Applied Thermal Engineering*, vol 51, 711-722.
- Thome, J.R. (2010). "Wolverine Tube Inc Engineering Data Book III". Web based book available at [www.wlv.com/heat-transfer-databook/](http://www.wlv.com/heat-transfer-databook/)
- Vaja, I. (2009). "Definition of an object oriented library for the dynamic simulation of advanced energy systems: Methodologies, Tools and Applications to Combined ICE&ORC Power Plants". *PhD Thesis University of Parma*

## APPENDIX

A	Area	m <sup>2</sup>
Cc	Cubic capacity	m <sup>3</sup>
c <sub>p</sub>	Specific heat	J/kg/K
D	Transfer function delay	s
G	Transfer function Gain	K/kg/s
h	Enthalpy	J/kg
$\dot{m}$	Mass flow	kg/s
N	Speed	rpm
P	Pressure	Pa
$\dot{Q}$	Heat flow rate	W
s	Entropy	J/kg/K
t	time	s
T	Temperature	K / °C
V	Volume	m <sup>3</sup>
$\dot{W}$	Power	W
z	Space length	m

Table 2 Latin letters

$\alpha$	Heat Transfer Coefficient	W/m <sup>2</sup> /K
$\mu$	Viscosity	Pa.s
$\lambda$	Heat Conductivity	W/K
$\rho$	Density	kg/ m <sup>3</sup>
$\tau$	Transfer function time constant	s

Table 3 Greek letters