



**HAL**  
open science

# Tracking of optimal trajectories for power plants based on physical models

M. Fouquet, Hervé Guéguen, Didier Dumur, Damien Faille

► **To cite this version:**

M. Fouquet, Hervé Guéguen, Didier Dumur, Damien Faille. Tracking of optimal trajectories for power plants based on physical models. 9th IFAC Symposium on Control of Power and Energy Systems (CPES), Dec 2015, New Delhi, India. pp.373-378, 10.1016/j.ifacol.2015.12.407 . hal-01261546

**HAL Id: hal-01261546**

**<https://hal.science/hal-01261546v1>**

Submitted on 12 Mar 2020

**HAL** is a multi-disciplinary open access archive for the deposit and dissemination of scientific research documents, whether they are published or not. The documents may come from teaching and research institutions in France or abroad, or from public or private research centers.

L'archive ouverte pluridisciplinaire **HAL**, est destinée au dépôt et à la diffusion de documents scientifiques de niveau recherche, publiés ou non, émanant des établissements d'enseignement et de recherche français ou étrangers, des laboratoires publics ou privés.

# Tracking of optimal trajectories for power plants based on physical models

Manon Fouquet \* Hervé Guéguen \*\* Didier Dumur \*\*\* Damien Faille \*

\* EDF R&D, Chatou, France (e-mail: manon.fouquet@edf.fr).

\*\* IETR CentraleSupélec, Cesson Sévigné, France (e-mail: herve.gueguen@centralesupelec.fr)

\*\*\* L2S CentraleSupélec, Gif sur Yvette, France

**Abstract**The paper deals with tracking of optimal trajectories for large scale non linear systems like power plants. It is assumed that an accurate nonlinear model of the plant is available, but because of its size and complexity, it cannot be used directly for long term dynamic optimization. For this reason, reference input and output trajectories are obtained from a simplified optimization model. Then a tracking Model Predictive Control (MPC) algorithm based on tangent linear approximations of the nonlinear model along a nominal trajectory is used to correct the trajectories. It includes input and output constraints, state estimation and disturbances rejection. The concept is shown on the tracking of optimal trajectories by a Combined Heat and Power plant with heat storage and time varying electricity price.

## 1. INTRODUCTION

Dynamic optimization of power plants has gained increased interest in the context of time varying prices, multi-energy production and use of energy storage. There is a trend to build detailed physical models of power plants based on first laws as they are very useful tools to simulate the dynamic behavior and predict quantities such as pressure, temperature and flow rate. Modelling languages such as Modelica (see Modelica (2014)) are particularly suited since they remove the burden of assigning causality to the variables and solving algebraic loops by hand. However, these complex models are generally not suited for dynamic optimization as they tend to have a very large number of variables, equations and hybrid parts. Therefore, simplified optimization models, commonly Mixed Integer Linear Programs (MILP) are used for long term optimization. A drawback is that physical quantities are no longer modelled with this approach, and simplification may also lead to important drift between the predicted optimal trajectories and the real system. An on-line correction of the plant inputs to follow the optimal reference trajectories is here proposed by a specific Model Predictive Control (MPC). MPC is a control method based on optimizing the input trajectories of a system using an internal model of it. It can handle constraints on both inputs and outputs. In conventional linear MPC, see Maciejowski (2000) or Camacho (2004), the goal is generally to reach a fixed output set-point with an optimal transient. The purpose of the MPC proposed in this paper is to follow a non-stationary reference on outputs, but also on inputs. The compromise between input and output tracking is found by the MPC. The MPC employs directly the complex nonlinear model to generate tangent linear approximations of the plant around a nominal trajectory. Tangent linear MPC was reported in Borrelli et al. (2005) or Falcone et al. (2007) but equations were derived manually on small size models (7 and 9 states). In this paper, the tangent linear models are derived automatically on large differential-algebraic models (at least 30 states), using the

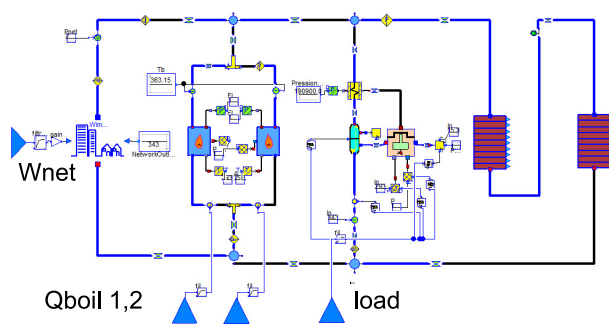

Figure 1. Nonlinear Modelica<sup>®</sup> model of a CHP plant potential of Modelica for index reduction and automatic differentiation.

## 2. COMBINED HEAT AND POWER PLANT

The Combined Heat and Power plant to control is used for hot water production in a district heating network. The CHP uses a 1.4 MWe/1.7MWth engine to generate electricity. Heat is recovered by two heat exchangers: the first one on the engine cooling water, the second one on hot exhaust gas. The engine thermal and electric efficiencies depend on the engine load. Beside of that, two parallel boilers of 1.6 MWth may be used to produce additional heat. Two water tanks of 135 cubic meters each are also available for heat storage. Hot water is injected and withdrawn from the top, while cold water flows to and from the bottom. This results in temperature stratification within the storage. Fuel, water and air flowrates to the engine and boilers are internally regulated in order to produce 90°C hot water. A model of the power plant was developed with Modelica and the library ThermoSysPro, see Deneux et al. (2013). Figure 1 shows the nonlinear Modelica<sup>®</sup> model of the plant which is used in the MPC. It has 31 states and 726 algebraic variables. Nonlinearities include among others computation of fluid properties, temperature stratification in the storage and efficiency curves of the engine. The plant

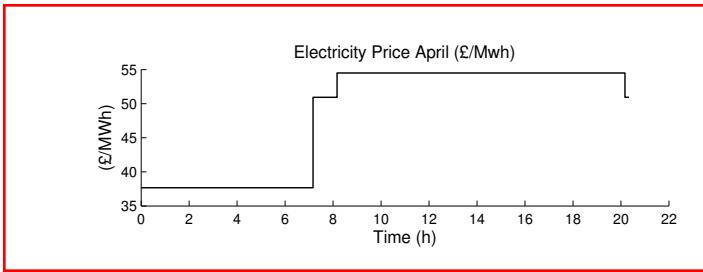

Figure 2. Price curve for April

has three controlled inputs: the electric load of the engine and the thermal loads of the two boilers. Heat demand from the network is modeled as an exogenous input. On the other hand, a simplified MILP optimization model developed is used for economic optimization of the plant on one day horizon. The cost function for the long term optimization depends upon the heat demand forecast, the electric power produced that can be sold at a time varying price, the fuel consumption and some maintenance costs for the engine. An example of the price curve for April is depicted in Figure 2. Constraints on the operating range of the engine and boilers as well as on the maximum number of start-ups are also included. However, the MILP model is an energy based description of the plant, and do not model the aforementioned nonlinearities, nor important quantities like temperatures or flow-rates. It does not either consider that the actual process is subject to some unmeasured or measured disturbances, such as the uncertainty in the thermal demand from the district heating network. This justifies the need for the trajectory correction presented below.

### 3. TANGENT LINEAR MPC

#### 3.1 Notations

In this paper, continuous and discrete trajectories are used. For a variable  $v$ ,  $v_k$  refers to the value of  $v$  at sample time  $t_k$ ,  $v(t)$  to the value of  $v$  at any time  $t$ , and  $v$  refers to the whole trajectory of  $v$ . Superscript  $i$  is used when a quantity is computed at time  $t_i$ : for example  $v^i(t_{i+1})$  is the value of  $v$  at  $t_{i+1}$  computed at  $t_i$ .

In the MPC procedure, vectors representing the value of variables at the next sample times are computed, with a receding horizon. Capital letters with superscript  $i$  are used to define these sequences from the sample time  $t_i$ , over the corresponding MPC horizon. Hence  $V^i$  contains the values of  $v_{i+k}$  with  $k$  in a range defined by the MPC parameters. The notation  $\Delta$  is finally introduced to define the time variation of a variable  $v$  between two sample times:  $\Delta v_k = v_k - v_{k-1}$ .

#### 3.2 General architecture

The MILP model of the plant, which models slow dynamics of the system, is used for long term economic scheduling (typically on one day horizon with half an hour sampling time) and provides optimal reference trajectories ( $u_{ref}$  and  $y_{ref}$ ) for the plant. Both inputs and outputs are used as reference since they are often related to various costs, profits, or engagements towards customers (e.g. fuel cost for inputs, sales of energy for outputs). Then a tracking MPC based on a tangent linear approximation of the accurate nonlinear model is introduced in order to correct

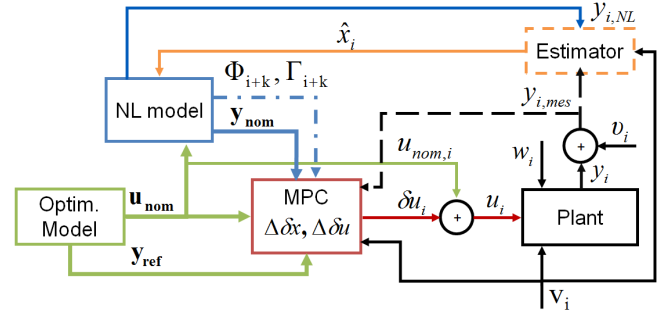

Figure 3. Architecture of the tangent linear MPC

the deviation due to the mismatch between the optimization model and the plant, as well as disturbance acting on the system. The purpose of the MPC is to find the optimal adjustment  $\delta u$  to the reference input  $u_{ref}$  on a short horizon, and to guarantee that input and output constraints are respected. In particular, some inputs and outputs are not truly continuous as they may be either within a fixed operating range, or set to zero.

Modelica<sup>®</sup> which was used to build the complex model is very interesting because it can provide analytical expressions for jacobian matrices using e.g. algorithmic differentiation, see Andersson et al. (2012). This will be used to derive the tangent linear model from the nonlinear one along a nominal trajectory. The nominal trajectories of states and outputs ( $x_{nom}$  and  $y_{nom}$ ) correspond to the predicted open loop response of the plant, obtained by simulating the nonlinear model with the reference input trajectory  $u_{ref}$  (therefore one also have  $u_{ref} = u_{nom}$ ). To sum it up, the following architecture illustrated in Figure 3 is employed and will be detailed subsequently:

- **Step 0:** The simplified optimization model computes reference trajectories for inputs ( $u_{ref} = u_{nom}$ ) and outputs ( $y_{ref}$ ) on a large horizon  $H$  (one day for the CHP).
- **Step 1:** Based on plant measurements, a state estimator is used to ensure that the current state of the nonlinear model represents the state of the plant.
- **Step 2:** The nonlinear model is simulated over the MPC horizon  $P$  with the reference inputs  $u_{ref}$ . It gives the predicted nominal trajectory of states  $x_{nom}$  and outputs  $y_{nom}$ . Matrices of the tangent linear approximation along this nominal trajectory are also computed meanwhile. A long prediction horizon provides good MPC performance. However it also increases the computation time. Therefore, a compromise needs to be found for the prediction horizon (a couple of hours for the CHP).
- **Step 3:** The MPC adapts the reference input  $u_{ref}$  to make the plant track the reference trajectories  $y_{ref}$ , with a compromise between input and output tracking. Input and output constraints are considered at this step and will be detailed in section 3.4. A peculiar set of constraints that are specific to power plants concerns devices that may be switched on or off. Such devices may be either set to 0 or be operated in a given operating range. As the proposed MPC is a local trajectory correction, it is emphasized that it may adapt the values of inputs but does not modify the unit commitment (which is a logic decision). Therefore the MPC cannot act on a device which is switched off.

Disturbance are also considered by the MPC and may be seen as uncontrolled inputs of the system. Forecasts are used as nominal trajectories for disturbance, a typical example being outdoor temperature or heat demand for the CHP plant.

- *Step 4:* Only the first control value is applied to the plant and the nonlinear model, and the MPC procedure (1-4) is restarted.

The tangent linear model is used instead of the nonlinear model for various reasons. First, it reduces the nonlinear model to a Linear Time Varying one, which is an accurate first order approximation of the plant behavior around all the nominal trajectory. Moreover LTV models may be used in the framework of linear MPC, and one can therefore benefit from its guaranteed optimization convergence. However, some modification to the standard linear MPC are required with this formulation and will be detailed in the next parts.

### 3.3 Non linear model

The plant is modeled with nonlinear differential-algebraic equations. With  $x \in \mathbf{R}^{n_x}$  the differential states,  $y \in \mathbf{R}^{n_y}$  the outputs,  $u, v, w \in \mathbf{R}^{n_u} \times \mathbf{R}^{n_v} \times \mathbf{R}^{n_w}$  respectively the controlled, measured/uncontrolled and unmeasured/uncontrolled inputs (i.e. perturbations), the nonlinear model is given by

$$\begin{cases} x_{NL}(t_0) = x_0 \\ \dot{x}_{NL}(t) = f(x_{NL}(t), u(t), v(t), w(t)) \\ y_{NL}(t) = h(x_{NL}(t)) \end{cases} \quad (1)$$

The operator  $\delta$  is introduced to define the deviation of a variable from its nominal value (e.g.  $\delta x(t) = x(t) - x_{nom}(t)$ ,  $\delta y(t) = y(t) - y_{nom}(t)$ ,  $\delta u(t) = u(t) - u_{nom}(t)$ , ...). The tangent linear model in a neighborhood of  $P_{nom} = (x_{nom}, y_{nom}, u_{nom}, v_{nom}, w_{nom})$  is given by

$$\delta \dot{x} = \dot{x} - \dot{x}_{nom} \approx \frac{\partial f}{\partial x} \delta x + \frac{\partial f}{\partial u} \delta u + \frac{\partial f}{\partial v} \delta v + \frac{\partial f}{\partial w} \delta w \quad (2)$$

Using this linearization formula at each sample time and a zero order hold approximation for the inputs on one sample interval, (2) may be rewritten in a sampled framework as the following Linear Time Varying system :

$$\begin{cases} \delta x_{k+1} = \phi_k \delta x_k + \gamma_k \begin{pmatrix} \delta u_k \\ \delta v_k \end{pmatrix} + \gamma_{w,k} \delta w_k \\ \delta y_k = c_k \delta x_k \end{cases} \quad (3)$$

The matrices  $\phi_k$ ,  $\gamma_k = [\gamma_{u,k}, \gamma_{v,k}]$ ,  $\gamma_{w,k}$  and  $c_k$  are obtained by discretizing the linearization matrices around  $P_{nom}$  over one sampling period.

### 3.4 MPC formulation

The vectors used in the MPC are

$$U^i = \begin{pmatrix} u_i \\ \vdots \\ u_{i+M-1} \end{pmatrix}, \Delta U^i = \begin{pmatrix} \Delta u_i \\ \vdots \\ \Delta u_{i+M-1} \end{pmatrix}, Y^i = \begin{pmatrix} y_{i+1} \\ \vdots \\ y_{i+P} \end{pmatrix}$$

$\|A\|_X$  defines the norm  $A^T X A$ , with X a square positive semi definite matrix. The following expression is chosen as a cost function for the MPC:

$$J_i = \|U - U_{ref}^i\|_{Q_u} + \|Y - Y_{ref}^i\|_{Q_y} + \|\Delta U^i\|_R \quad (4)$$

The first two terms are related to the quality of tracking for the input and output reference trajectories. The compromise between good input tracking and good output tracking

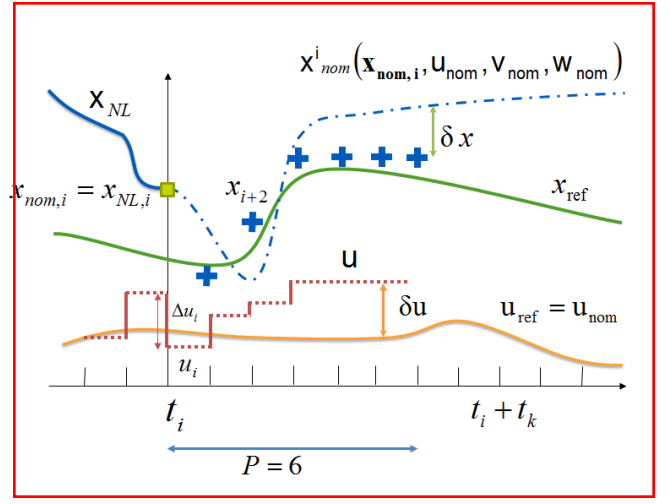

Figure 4. Definition of input and output trajectories

is expressed by the weighting matrices  $Q_u$  and  $Q_y$ . Finally, in order to avoid too quick variations of the input, a penalization on the term  $\Delta U^i$  may also be added with a weighting matrix  $R$ .

Several constraints are finally added to the problem :

- Bounds on inputs  $u_{min}(t_i) \leq u_i \leq u_{max}(t_i)$
- Bounds on outputs  $y_{min}(t_i) \leq y_i \leq y_{max}(t_i)$
- Bounds on the deviation from the nominal trajectory  $\delta u_{min} \leq \delta u \leq \delta u_{max}$  and  $\delta y_{min} \leq \delta y \leq \delta y_{max}$

As one may notice, bounds on inputs and outputs are allowed to be time varying for the specific case of variables that can be either zero (OFF) or between a minimum and a maximum level (ON). The state of a device is defined from the reference trajectory given by the MILP.

Figure 4 shows the different variables used in the MPC, in the case where the output  $y$  and the state  $x$  are the same. The actual output  $x_{NL}$  of the plant up to current time  $t_i$  is in solid blue line. The reference trajectories given by the MILP are shown in solid line:  $u_{ref} = u_{nom}$  (orange) for the input and  $y_{ref}$  (green) for the output. Then the nominal output trajectory (dash-dotted blue line) computed at time  $t_i$  is obtained by simulating the nonlinear model with the nominal input  $u_{nom}$ , starting from the current state  $x_{NL,i}$ . As may be seen, the nominal trajectory of the output is different from the reference trajectory, justifying the need for a MPC correction. Inputs  $u$  are therefore adapted (red stairs) over the MPC horizon  $P$  so that the predicted system behavior (blue crosses) improves the trajectory tracking over  $P$ . The figure also depicts operator  $\delta$ , the gap between the nominal and predicted value of the variable, as well as operator  $\Delta$ , the variation of a variable between two sample times. One may notice that at every step  $t_k$ , the nominal trajectory is re-initialized with the estimated state of the plant, therefore:  $x_{nom,k}^k = x_{NL,k}$ .

### 3.5 Internal augmented model

As suggested by Camacho (2004), an augmented model using the variation of  $\delta u$  between two sample times and the current state is used as internal model for the MPC:  $x_{a,k} = \begin{pmatrix} \delta x_k \\ \delta u_{k-1} \end{pmatrix}$ . The unmeasured disturbance  $w$  is assumed to have its nominal value  $w_{nom}$ . Therefore  $\delta w = 0$  in the internal model and may be removed. From equation (3)

$$\begin{aligned} \begin{matrix} x_{a,k+1} \\ \delta x_{k+1} \\ \delta u_k \\ \delta y_k \end{matrix} &= \begin{matrix} \Phi_k \\ \begin{bmatrix} \phi_k & \gamma_{u,k} \\ 0 & I \end{bmatrix} \\ C_k \end{matrix} x_{a,k} + \begin{matrix} \Gamma_{u,k} \\ \begin{bmatrix} \gamma_{u,k} \\ I_{n_u} \end{bmatrix} \end{matrix} \Delta \delta u_k + \begin{matrix} \Gamma_{v,k} \\ \begin{bmatrix} \gamma_{v,k} \\ 0_{n_v} \end{bmatrix} \end{matrix} \delta v_k \end{aligned} \quad (5)$$

At each MPC step, the nominal trajectory is recomputed by simulation starting from  $x_i = x_{nom,i}$  and the measured disturbance  $v_i = v_{mes,i}$ . Therefore, at step  $i$ ,  $\delta x_i = 0$  in the augmented model. The same reasoning applies for  $v$ : the nominal trajectory  $V_{nom}^i$  is updated as soon as new measurement becomes available. One may therefore assume that  $\delta v_{i+k} = v_{i+k} - v_{nom,i+k} = 0$  and remove it from the internal model.

### 3.6 MPC reformulation with the augmented model

Objective and constraints on both inputs and outputs can be reformulated explicitly according to the optimization variable  $\Delta \delta u$  of the internal model. *Inputs*: Noticing that

$$\begin{aligned} \Delta \delta u_k &= \Delta u_k - \Delta u_{nom,k} \\ \sum_{n=1}^k \Delta u_{nom,n} &= u_{nom,k} - u_{nom,0} \\ u_{i+k} &= u_{i-1} + \sum_{n=0}^k \Delta u_{i+n} = u_{i-1} + \sum_{n=0}^k (\Delta \delta u_{i+n} + \Delta u_{nom,i+n}) \end{aligned}$$

One may rewrite inputs on the MPC horizons as

$$U^i = \begin{pmatrix} \delta u_{i-1} \\ \vdots \\ \delta u_{i-1} \end{pmatrix} + U_{nom}^i + L \Delta \delta U^i \quad (6)$$

$$\Delta U^i = \Delta \delta U^i + \Delta u_{nom,i} \quad (7)$$

$$\delta U^i = \begin{pmatrix} \delta u_{i-1} \\ \vdots \\ \delta u_{i-1} \end{pmatrix} + L \Delta \delta U^i \quad (8)$$

where  $L$  is the  $n_u * M$  square lower triangular matrix of ones.

*Outputs*: Outputs may also be expressed as a function of the optimization vector  $\Delta \delta U^i$ . As mentioned earlier, the uncontrolled inputs  $v$  and  $w$  are assumed to be at their nominal values. Therefore  $\delta w_{i+k} = \delta v_{i+k} = 0, k \in \overline{1..P}$ . Using these assumptions, the sequence of outputs may be written as:

$$\delta Y_i = S_x^i x_{a,i} + S_u^i \Delta \delta U^i \quad (9)$$

*Constraints and cost function*: Constraints and the cost function may then be reformulated using (6)-(9) into the following quadratic program :

$$\begin{aligned} \min_{\Delta \delta U^i} & \|U_f^i + L \Delta \delta U^i\|_{Q_u}^2 + \|Y_f^i + S_u^i \Delta \delta U^i\|_{Q_y}^2 + \|\Delta \delta U^i + \Delta U_{nom}^i\|_R^2 \\ \text{s.t.} & \\ & (U_{min}^i - \delta u_{i-1}) \otimes \mathbf{1} \leq L \Delta \delta U^i + U_{nom}^i \leq (U_{max}^i - \delta u_{i-1}) \otimes \mathbf{1} \\ & (\delta u_{i-1} - \delta u_{max}) \otimes \mathbf{1} \leq L \Delta \delta U^i \leq (\delta U_{max}^i - \delta u_{i-1}) \otimes \mathbf{1} \\ & Y_{min}^i - Y_{nom}^i \leq S_u^i \Delta \delta U^i \leq Y_{max}^i - Y_{nom}^i \\ & -\delta Y_{max} \leq S_u^i \Delta \delta U^i \leq \delta Y_{max} \end{aligned}$$

With  $U_f = \begin{pmatrix} \delta u_{i-1} \\ \vdots \\ \delta u_{i-1} \end{pmatrix}$ , With  $Y_f = Y_{nom} - Y_{ref}$ ,  $U_f = \delta u_{i-1}$ ,

$\otimes$  the Kronecker product,  $\mathbf{1}$  a vector of all ones of appropriate length. In the software implementation, these constraints can be softened (excursion out of the constraint is

penalized rather than forbidden) in order to avoid infeasibility issues.

### 3.7 State Estimator

Using the available measurements, the model state is re-adjusted at each step to match the true state of the plant. Indeed, mismatch between the plant and the non linear model can be caused by several factors:

- Prediction error  $\delta w$  of the unmeasured disturbance assumed to be white noise of covariance  $W$
- measurement noise  $v$  assumed to be additive white noise of covariance  $V$
- modeling error modeled by an additive white noise  $w_m$  of covariance  $W_m$  in the state equation (3).

A time varying Extended Kalman Filter is used for state estimation based on the tangent linear model (3). First the predicted state  $\tilde{x}_i$  and output  $\tilde{y}_i$  at stage  $i$  are computed, then the current internal state  $x_{NL,i}$  is adjusted according to the new measurement:

$$\begin{cases} \tilde{x}_i = F(x_{NL,i-1}, u_{i-1}, v_{i-1}, w_{nom,i-1}, T_{samp}) \\ \tilde{y}_i = h(\tilde{x}_i) \end{cases} \quad (10)$$

$$x_{NL,i} = \tilde{x}_i + K_i (y_{mes,i} - \tilde{y}_i) \quad (11)$$

The gain  $K_i$  of the filter and update of the covariance matrix  $P$  at step  $i$  are given by:

$$K_i = P_i c_i^T (c_i^T P_i c_i + V)^{-1} \quad (12)$$

$$P_{i+1} = \phi_i (I - K_i c_i) \phi_i^T + \gamma_{w,i} W \gamma_{w,i}^T + W_m \quad (13)$$

### 3.8 Reference trajectories

Reference trajectories given by the MILP model contain only one point per optimization sample time. This rises the question of a suitable interpolation. In the presented work, piecewise constant signals are used for flow quantities such as electric power or flow-rates. However, differential variables such as the state of charge of the storage require a higher order modeling (e.g. linear interpolation or splines). Linear interpolation was used for its simplicity. Moreover, it cannot lead to reference trajectories that violate bounds constraints between the interpolation points (which can occur with splines).

## 4. TANGENT MPC IMPROVEMENT FOR POWER PLANTS

### 4.1 MPC speed-up

In order to significantly reduce the computation time of  $S_u$  and  $S_x$  given in equation (10), one can assume that the linearization matrices  $\Phi_k$ ,  $\Gamma_k$  and  $C_k$  at a given point in time will change little between iteration  $i$  and  $i+1$  of the MPC algorithm. Using this assumption, only one new linearization at time  $t_{i+P+1}$  is needed instead of  $P$  linearization. Nonetheless, the simulation of the nominal trajectory on  $P$  steps ahead has to be done at each step in order to start from the current estimated state of the plant.

### 4.2 Direct feedthrough

Systems with direct feed-through from the inputs to the outputs have a non-zero  $D = \frac{\partial g}{\partial u}$  matrix and complicates

$$S_u^i = \begin{pmatrix} C_{i+1}\gamma_{u,i} & 0 & \dots & 0 \\ C_{i+2}\Phi_{i+1}\gamma_{u,i} & C_{i+2}\gamma_{u,i+1} & \dots & 0 \\ \vdots & \vdots & \ddots & \vdots \\ C_{i+P-1} \prod_{n=1}^{P-2} \Phi_{i+P-1-n}\gamma_{u,i} & C_{i+P-1} \prod_{n=1}^{P-3} \Phi_{i+P-1-n}\gamma_{u,i+1} & \dots & C_{i+P-1}\gamma_{u,i+M-2} \\ C_{i+P} \prod_{n=1}^{P-1} \Phi_{i+P-n}\gamma_{u,i} & C_{i+P} \prod_{n=1}^{P-2} \Phi_{i+P-n}\gamma_{u,i+1} & \dots & C_{i+P}\gamma_{u,i+M-1} \end{pmatrix} \quad S_x^i = \begin{pmatrix} C_{i+1}\Phi_i \\ C_{i+2}\Phi_{i+1}\Phi_i \\ \vdots \\ C_{i+P}\Phi_{i+P-1}\dots\Phi_{i+1}\Phi_i \end{pmatrix} \quad (10)$$

the expression of the quadratic program.  $D$  is therefore eliminated from the internal model by changing  $\delta y$  by  $\delta \bar{y}_k = \delta y_k - d_k \delta u_k$ . The matrices  $S_d^i$  and  $L_1$  are defined as :

$$S_d^i = \begin{pmatrix} d_{i+1} & \dots & 0 \\ \vdots & \ddots & \vdots \\ 0 & \dots & d_{i+P-1} \end{pmatrix} \quad L_1 = \begin{pmatrix} 1 & 1 & 0 & \dots & 0 \\ 1 & 1 & 1 & \dots & 0 \\ \vdots & \vdots & \vdots & \ddots & \vdots \\ 1 & 1 & 1 & \dots & 1 \\ 1 & 1 & 1 & \dots & 1 \end{pmatrix}$$

The output may then be expressed as

$$Y^i = Y_{nom}^i + (S_d^i L_1 + S_u^i) \Delta \delta U^i + S_d^i (\delta u_{i-1} \otimes \mathbf{1}) + S_x^i x_{a,i}$$

### 4.3 Scaling

Variables in power plants are physical quantities with defined units and large variations in their order of magnitude. As an example, the storage size expressed in Joule is in the range  $10^{10}$  while the flow-rates range from  $10^{-1}$  to  $10^1$  kg/s. This aspect may lead to very ill conditioned matrices when solving the quadratic program. Therefore, scaling of the variables is performed by considering their maximum value (either given within the model or taken from the optimization bounds for inputs and outputs). Defining  $N_v$  as diagonal matrices with diagonal term on row  $i$  :  $N_{v,i} = v_{max,i} - v_{min,i}$  the scaled system in  $\bar{x}, \bar{u}, \bar{y}$  is given by:

$$x_k = N_x \bar{x}_k \quad u = N_u \bar{u}_k \quad y = N_y \bar{y}_k \quad (14)$$

$$\left\{ \begin{array}{l} \delta \bar{x}_{k+1} = N_x^{-1} \phi_k N_x \delta \bar{x}_k + N_x^{-1} \gamma N_u \delta \bar{u}_k \\ \delta \bar{y}_k = N_y^{-1} C N_x \delta \bar{x}_k + N_y^{-1} D N_u \delta \bar{u}_k \end{array} \right. \quad (15)$$

## 5. RESULTS

The MPC based on the nonlinear model is simulated in Figure 5 with the actual demand for a typical spring day. Heat demand forecast was obtained with a *Generalized Additive Model* (GAM) like the one described in Bissuel et al. (2013). It takes into account weather conditions, mostly temperature, but also other components such as calendar events and different seasonality. The heat demand profile is shown in the last chart (forecast in blue crosses, actual demand in solid black line). The MILP was run with the heat demand forecast using half an hour steps. Then, the nonlinear model of the plant was used as a virtual plant to simulate the system with and without MPC correction on one day, using the actual demand. The prediction horizon of the MPC was chosen  $P = 10$  with a sampling time of 10 min which corresponds to a receding horizon about one and a half hour. Thanks to the assumption described in part 4.1, only one new linearization, and one simulation starting from the current point are needed at each MPC step.

Two outputs depicted in the two upper rows have been chosen for tracking: the amount of energy in the storage and the temperature provided to the network. In the three rows below, one can see the inputs of the system: the electric load

of the engine and the thermal loads of the two boilers. For both inputs and outputs, blue crosses show the reference trajectories given by the MILP optimization, and dashed red lines show constraints.

*Definition of the objective function and constraints:* When a device is OFF according to the result of the MILP, the corresponding input is set to 0 by the MPC. Conversely, when the device is ON, hard constraints are used by the MPC to keep the inputs their operating range ( $[0.5; 1]$  for the engine load,  $[60; 100\%]$  for the boiler loads). Boilers are very reactive, so no weighting is put on their deviation from the reference. On the other hand, the reference for the engine load should be followed as much as possible and not exhibit too sharp variations : therefore one uses  $Q_u = \text{diag}(1, 0, 0)$  and  $R = \text{diag}(0.01, 0, 0)$ . For the outputs, it is chosen that the most important thing for the power plant is to follow the charging profile of the storage. The temperature to the network on the other hand should not follow strictly the reference temperature, but only be maintained in the band  $90 \pm 2^\circ\text{C}$ . Therefore the weighting matrix  $Q_y = 10, 0$  is chosen, and constraints are added to keep the storage energy and temperature within their allowed bounds. As shall be explained below, soft constraints are used for the outputs to avoid infeasibility issues, meaning that the excursion out of the bounds is strongly penalized in the objective function but not forbidden.

*Simulation:* The behavior of the plant with MPC is displayed with solid black lines. For the outputs, the magenta dash-dotted curve represents the behavior of the plant if the reference inputs (blue crosses) were applied in an open-loop way. Finally, at the end of the horizon (future), one can see the predictions done by the MPC for the future inputs in green dashed lines. A first thing to notice is that the temperature goes out of the bounds during the first hours. The reason is that all devices are switched off by the MILP at that time (and so all inputs are set to 0 by the MPC), meaning that only the storage is used to satisfy the heat demand. This kind of behavior may occur as the MILP is an energy-only model which does not consider the temperature profile in the storage, and especially the temperature of the top layer of water that feeds the network. Therefore, in order to ensure the safety of the power plant, boiler 1 has an emergency regulation that can bypass the MPC when the energy in the storage goes below a threshold : as can be seen on the third plot, this safety is triggered at 5 a.m.

The results show that the MPC is able to track the storage profile by adjusting the three inputs. A slightly better behavior is also observed for the temperature to the district heating network compared with the solution without MPC. Another point to notice is that without MPC correction (dashed magenta line), the energy in the storage deviates significantly from its reference. Therefore it may lead to some constraint violation that were unexpected from the MILP solution, for example if the optimization tells to

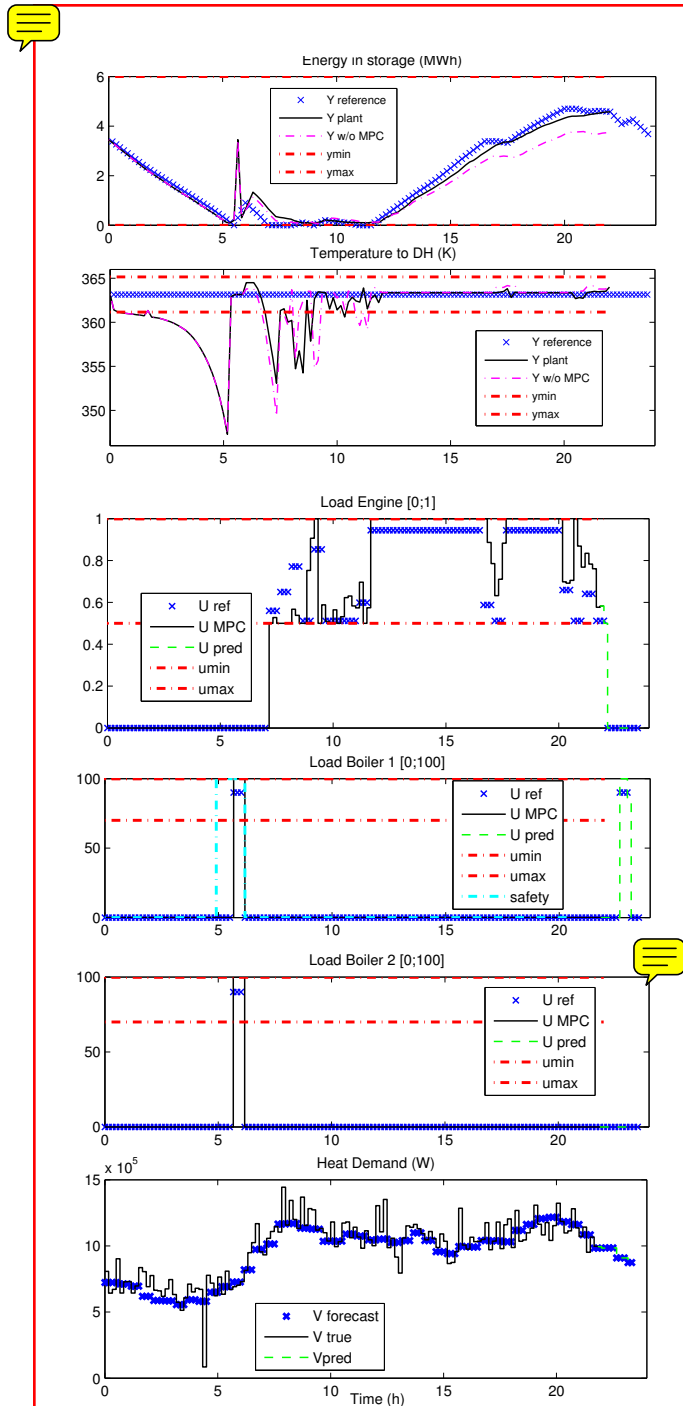

Figure 5. MPC on the CHP plant with the actual demand produce additional heat at a time when the storage is already filled-up (but was suppose to have still some capacity according to the MILP).

## 6. FUTURE WORK

Some issues still need to be addressed. An essential point is to decide when to re-compute a new optimal scheduling with the current state of the plant. It was explained that in some cases, the MPC has not enough control action on the plant to satisfy output constraints, especially because the MPC do not question the unit commitment done by the MILP (as it is a local correction around a nominal trajectory). However, the MPC is able to predict the future outputs of the plant with and without MPC on  $P$  steps

ahead, and therefore to detect if a constraint is likely to become violated. This information may be used to trigger a new evaluation of the MILP. The MILP should be updated with the current storage state and more recent heat load forecast if available. Finally, another opportunity is to provide MILP reference trajectories that are more robust to demand uncertainty. The progress of this work is detailed in Faille et al. (2015).

## 7. CONCLUSION

The optimal control problem of a CHP plant is addressed by the use of two models of different complexities. At first a simplified optimization model is used for long term trajectory planning. It provides the reference optimal trajectories for the system. Then an accurate non linear model is used to predict the behavior of the plant and to follow the optimal trajectories on a shorter horizon in a Tangent Linear Model predictive control framework. The proposed MPC has specific features tailored for physical models (respect of operating ranges, variable scaling). The proposed architecture can cope with measured and unmeasured disturbances, and is able to handle several types of constraints.

## REFERENCES

- Andersson, J., Åkesson, J., and Diehl, M. (2012). CasADi: A Symbolic Package for Automatic Differentiation and Optimal Control. In S. Forth, P. Hovland, E. Phipps, J. Utke, and A. Walther (eds.), *Recent Advances in Algorithmic Differentiation*, volume 87 of *Lecture Notes in Computational Science and Engineering*, 297–307. Springer Berlin Heidelberg. URL [http://dx.doi.org/10.1007/978-3-642-30023-3\\_27](http://dx.doi.org/10.1007/978-3-642-30023-3_27).
- Bissuel, C., Goude, C., and Pechine, B. (2013). Heat Load Forecasting. Taler, J. (ed.), Krakow.
- Borrelli, F., Falcone, P., Keviczky, T., and Asgari, J. (2005). MPC-based approach to active steering for autonomous vehicle systems. *International Journal of Vehicle Autonomous Systems*, 3(2), 265–291.
- Camacho, E.F. (2004). *Model predictive control*. Advanced textbooks in control and signal processing. Springer, London ; New York.
- Deneux, O., Hafni, B.E., Péchiné, B., Di Penta, E., Antonucci, G., and Nuccio, P. (2013). Establishment of a Model for a Combined Heat and Power Plant with ThermosysPro Library. *Procedia Computer Science*, 19, 746–753. doi:10.1016/j.procs.2013.06.098. URL <http://linkinghub.elsevier.com/retrieve/pii/S1877050913007060>.
- Faille, D., Fouquet, M., Péchiné, B., Ahallal, S., and El Gahoui, L. (2015). Robust planning for Combined Heat and Power production. In *To be published*.
- Falcone, P., Tufo, M., Borrelli, F., Asgari, J., and Tseng, H.E. (2007). A linear time varying model predictive control approach to the integrated vehicle dynamics control problem in autonomous systems. 2980–2985. IEEE. doi:10.1109/CDC.2007.4434137. URL <http://ieeexplore.ieee.org/lpdocs/epic03/wrapper.htm?arnumber=4434137>.
- Maciejowski, J. (2000). *Predictive Control with Constraints*. Prentice Hall.
- Modelica, A. (2014). *Modelica® - A Unified Object-Oriented Language for Systems Modeling*.