



**HAL**  
open science

## Two Qualitative Dynamics Semantics for SBGN Process Description Maps

Adrien Rougny, Christine Froidevaux, Loïc Paulevé

► **To cite this version:**

Adrien Rougny, Christine Froidevaux, Loïc Paulevé. Two Qualitative Dynamics Semantics for SBGN Process Description Maps. CMSB'15, Sep 2015, Nantes, France. 2015. hal-01258943

**HAL Id: hal-01258943**

**<https://hal.science/hal-01258943>**

Submitted on 19 Jan 2016

**HAL** is a multi-disciplinary open access archive for the deposit and dissemination of scientific research documents, whether they are published or not. The documents may come from teaching and research institutions in France or abroad, or from public or private research centers.

L'archive ouverte pluridisciplinaire **HAL**, est destinée au dépôt et à la diffusion de documents scientifiques de niveau recherche, publiés ou non, émanant des établissements d'enseignement et de recherche français ou étrangers, des laboratoires publics ou privés.

# Two Qualitative Dynamics Semantics for SBGN Process Description Maps

Adrien Rougny, Christine Froidevaux and Loïc Paulevé

Laboratoire de Recherche en Informatique, Orsay, FRANCE

UMR8623 Université Paris-Sud - CNRS

Contact: rougny@lri.fr

## Context

- Larger and larger reaction networks modelling various biological processes (from databases, automatic inference)
- Standards to represent reaction networks: e.g. **Systems Biology Graphical Notation Process Description language (SBGN-PD)**
- Analysis of the dynamics to understand and control these processes

## Motivations

- Qualitative semantics allows to capture **important dynamical features** (e.g. attractors, reachability) without numerical parameters
- Model SBGN-PD maps under **qualitative semantics**

We propose two semantics formalized by **asynchronous automata networks**: the *general semantics*, together with a refinement called *process conflicts*, and the *stories semantics*

## Asynchronous Automata Networks

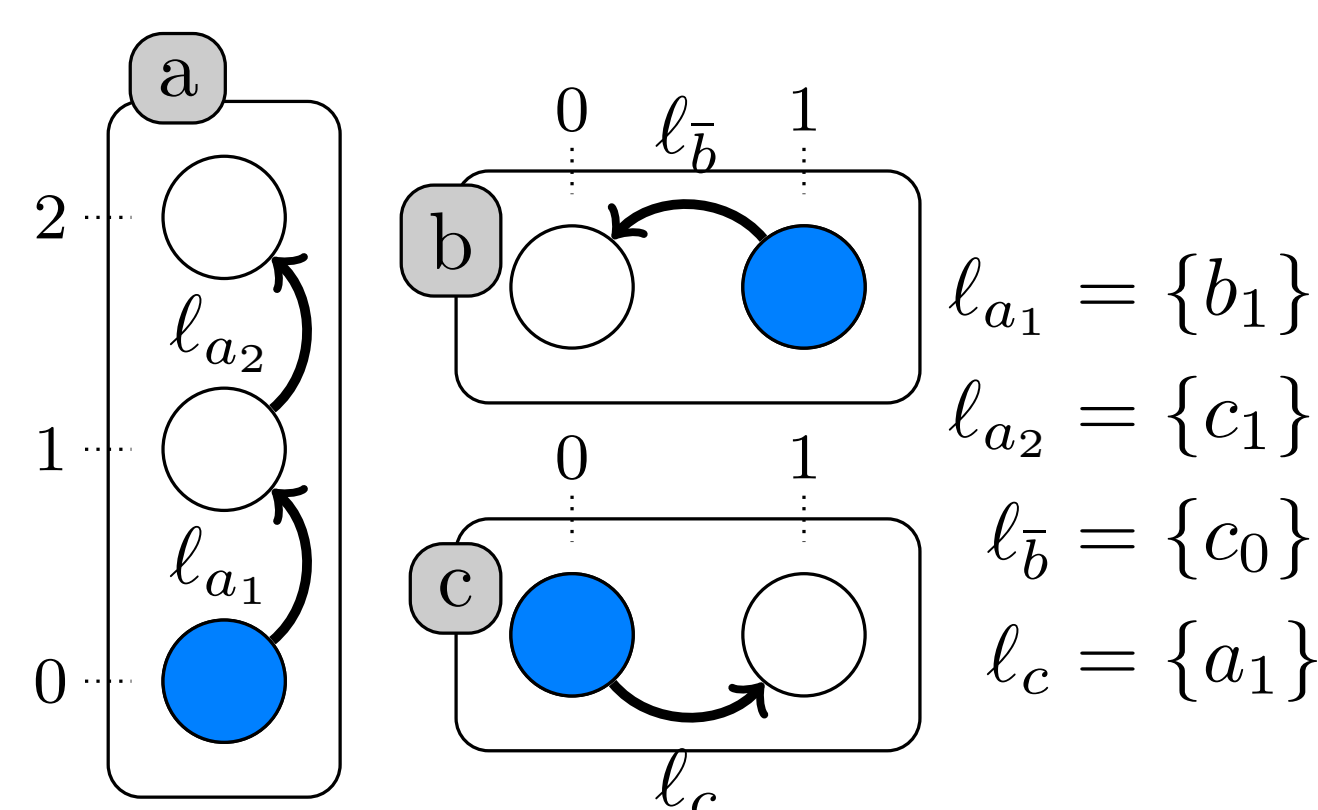

State transition graph:

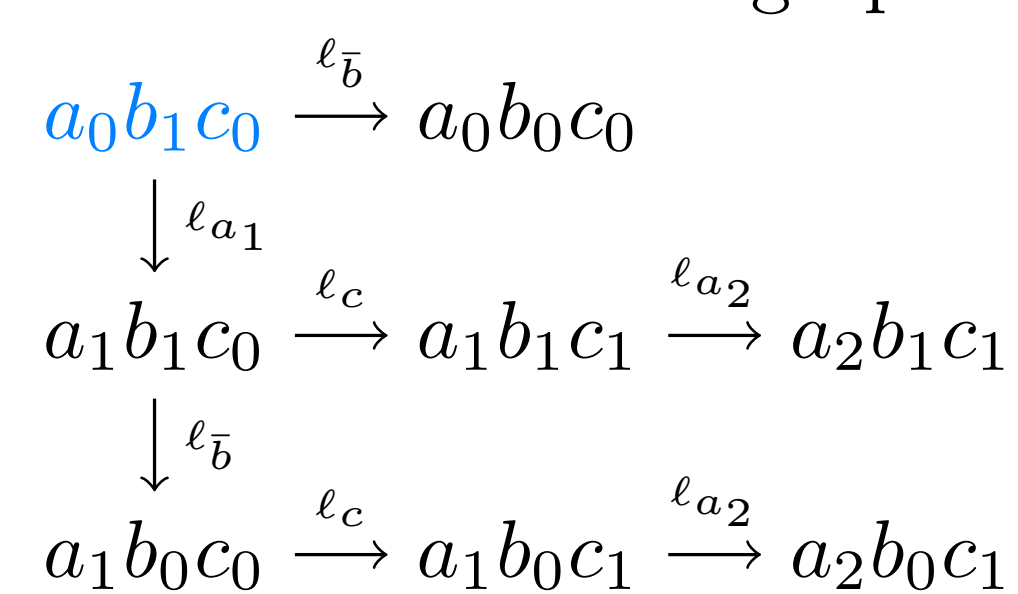

## General Semantics

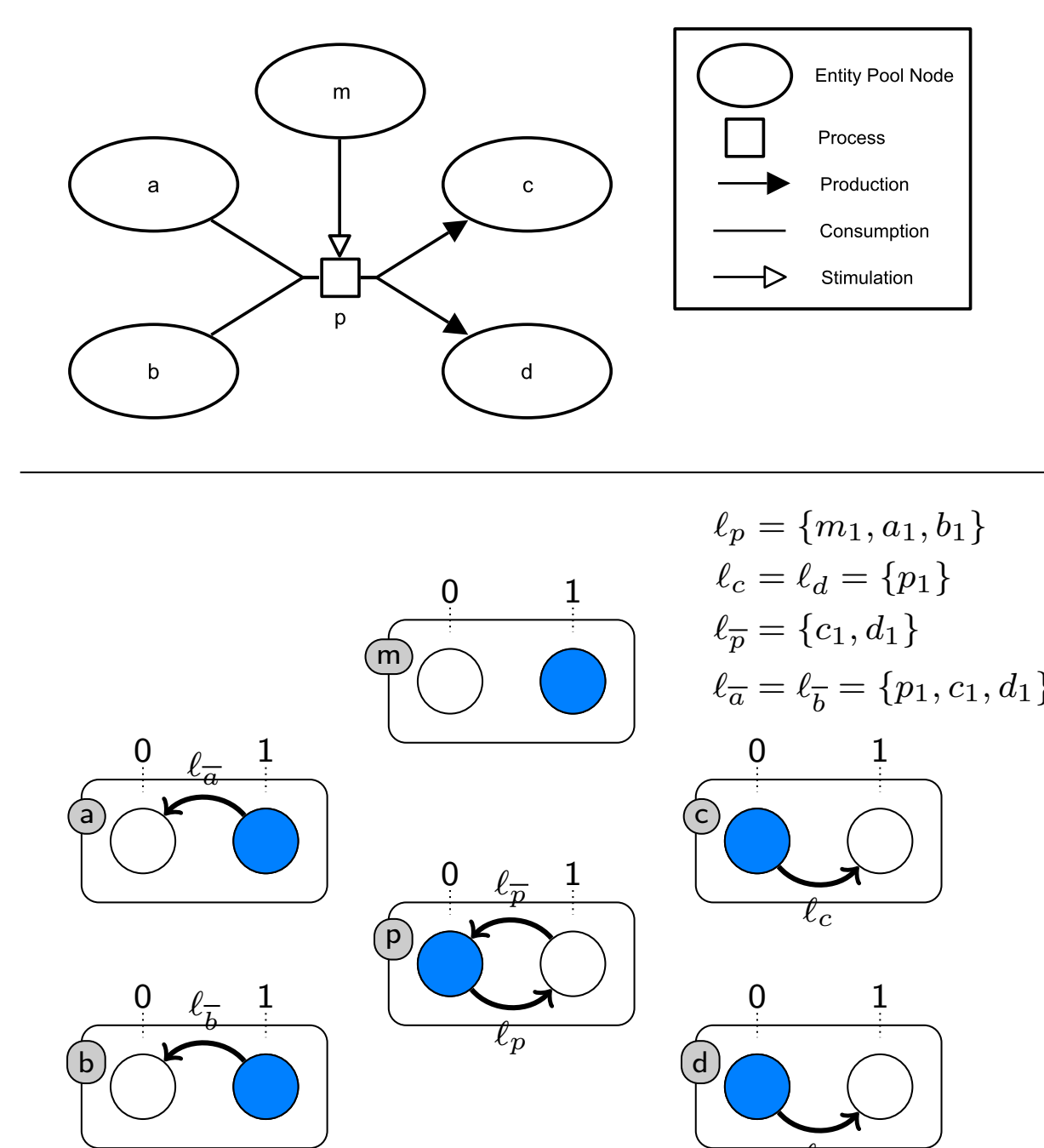

Each chemical entity is modelled by one automaton

## Refinement 1: Process Conflicts

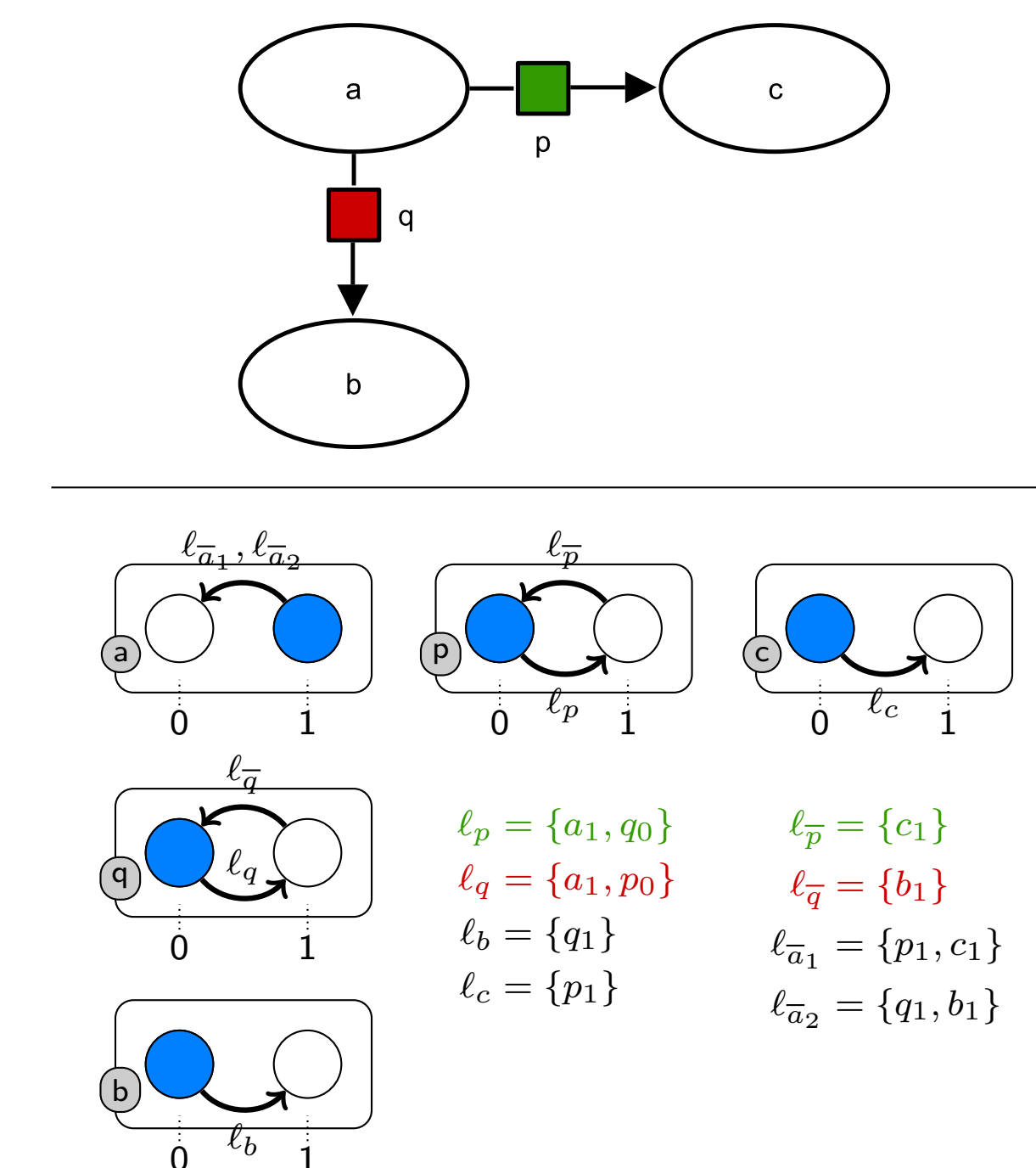

Processes  $p$  and  $q$  cannot occur at the same time

## Refinement 2: Stories Semantics

### Story:

- accounts for **successive transformations** of a chemical entity
- a set of entities that cannot be present at the same time, *i.e.* that are **mutually exclusive**

### Identification of stories:

- **automatic computation**
  - relevance determined by **expert knowledge**
- The stories semantics is a **refinement** of the general semantics driven by **expert knowledge**

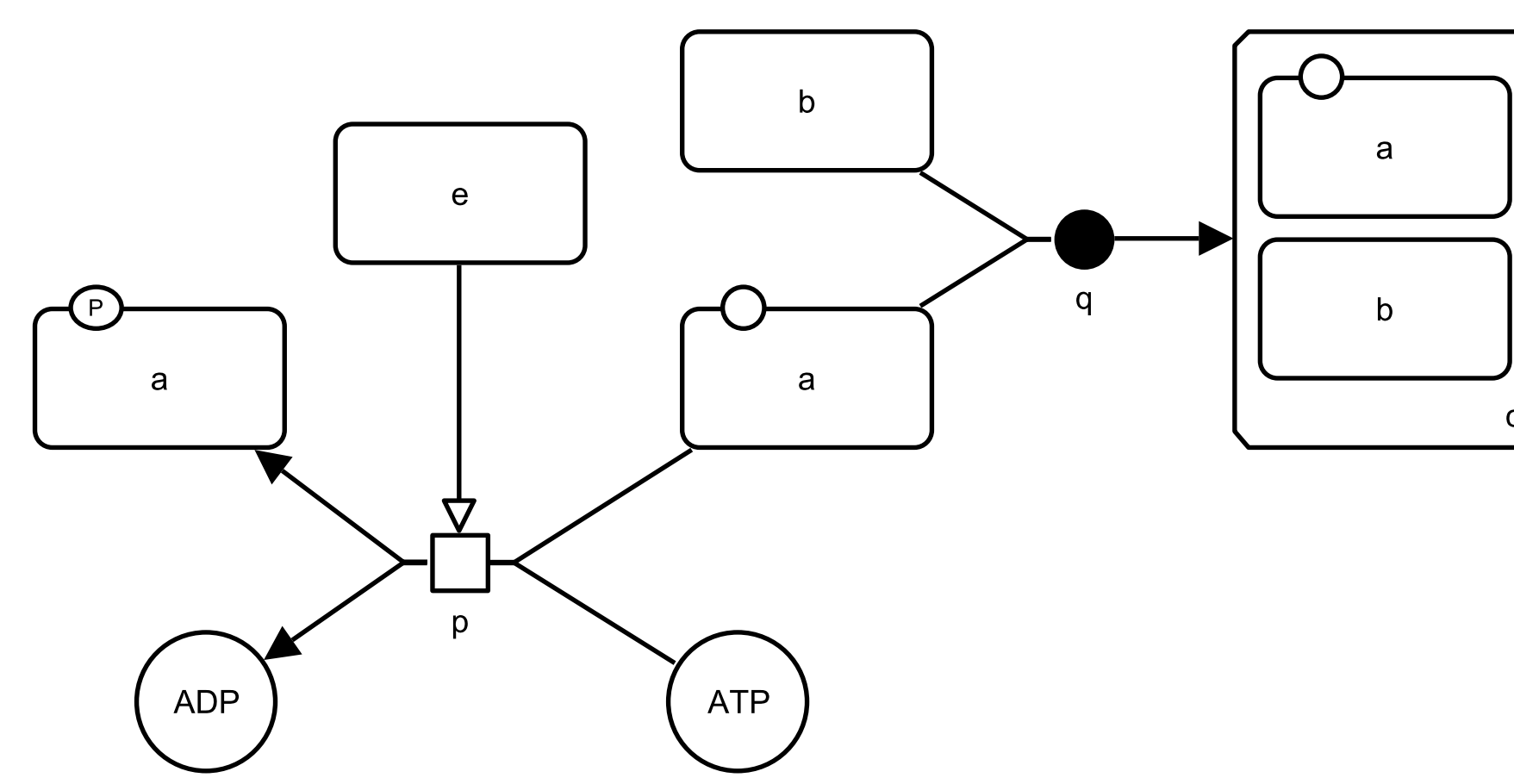

Set of non-singleton stories

$\{a, aP\}, \{a, c\},$   
 $\{b, c\}, \{a, aP, c\}$

Maximal sets of compatible stories

$\{a, c\}, \{a, aP, c\},$   
 $\{a, aP\}, \{b, c\}$

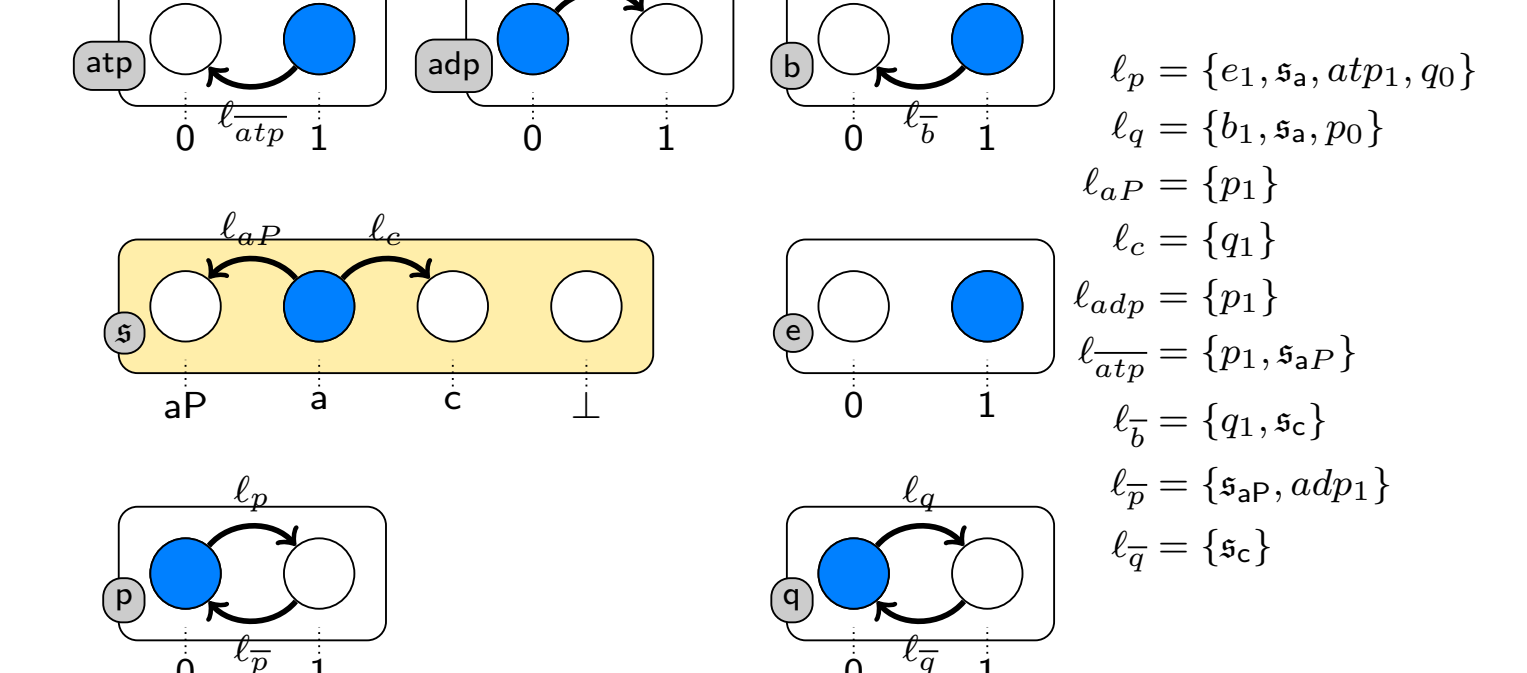
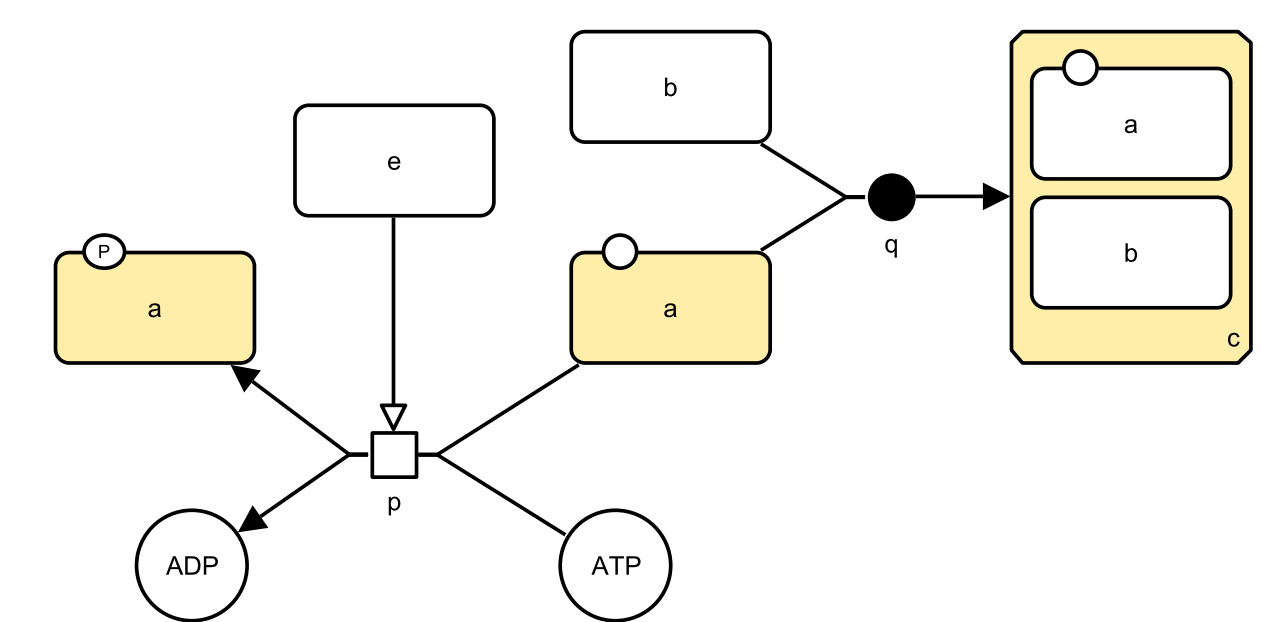

Stories reduce the dimension of the dynamics

## Example: the AT<sub>1</sub>A<sub>R</sub>-induced network

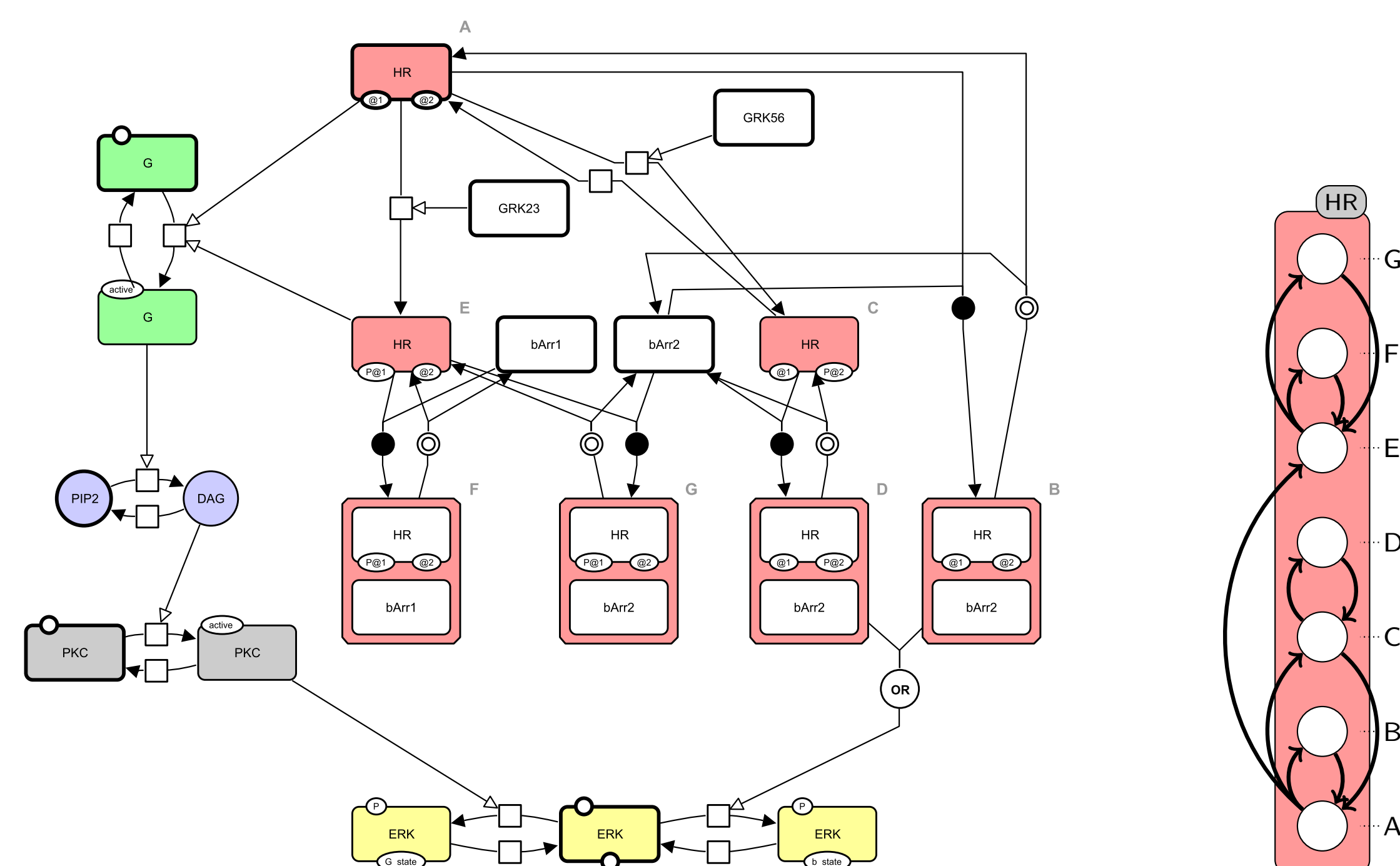

SBGN-PD map adapted from: D. Heitzler et al., *Competing G protein-coupled receptor kinases balance G protein and b-arrestin signaling*, MSB, 2012.

semantics	general	general with conflicts	stories
No. of automata	41	41	30
No. of reachable states	$\approx 10^{11}$	$\approx 10^{10}$	$\approx 10^5$

## Conclusion and Prospects

- **Main features** of SBGN-PD are supported
- The stories semantics is a refinement of the general semantics that:
  - models **several chemical species** with a **unique variable**
  - reduces the state space, **increasing the scalability** of the exhaustive computation of the dynamics
- The dynamics of SBGN-PD maps modelled under both semantics can be analyzed with **state-of-the-art tools** (PRISM, NuSMV ...)

### Ongoing work and prospects:

- Application to a **large network**, the E2F/RB pathway:
  - 153 out of 208 molecules in 28 stories
  - No. of automata reduced from 367 to 242
- Explore the relationship between the stories semantics and **Boolean semantics** applied to SBGN-AF maps