



HAL
open science

Cellular-based Real-Time Flow Repair for Broadcast Flows

Muhammad Moiz Anis, Xavier Lagrange, Ramesh Pyndiah

► **To cite this version:**

Muhammad Moiz Anis, Xavier Lagrange, Ramesh Pyndiah. Cellular-based Real-Time Flow Repair for Broadcast Flows. IEEE Transactions on Broadcasting, 2015, 61 (3), pp.457-469. 10.1109/TBC.2015.2450356 . hal-01256922

HAL Id: hal-01256922

<https://hal.science/hal-01256922v1>

Submitted on 30 Oct 2022

HAL is a multi-disciplinary open access archive for the deposit and dissemination of scientific research documents, whether they are published or not. The documents may come from teaching and research institutions in France or abroad, or from public or private research centers.

L'archive ouverte pluridisciplinaire **HAL**, est destinée au dépôt et à la diffusion de documents scientifiques de niveau recherche, publiés ou non, émanant des établissements d'enseignement et de recherche français ou étrangers, des laboratoires publics ou privés.



Distributed under a Creative Commons Attribution - NonCommercial 4.0 International License

Cellular-Based Real-Time Flow Repair for Broadcast Flows

Muhammad Moiz Anis, *Student Member, IEEE*, Xavier Lagrange, *Senior Member, IEEE*,
and Ramesh Pyndiah, *Senior Member, IEEE*

Abstract—Watching television on a portable device is possible on broadcast and cellular systems. With broadcast technologies, due to the absence of a feedback channel it is not possible to guarantee an error free reception at the receivers. With cellular technologies, the transmission is based on unicast and the same content is transmitted as many times as the number of people who are watching the same program in the cell. We propose to combine both technologies and consider the concept of repair-ing a broadcast data flow for dual-mode (cellular and broadcast) smartphones in real time in order to ensure a better quality of service. We propose to use the constrained application pro-ocol (CoAP) and specify a real-time flow repair (RFR) service based on CoAP in the cellular networks. We describe the archi-tecture to provide such a service. We analyze the load generated in the cellular radio access network due to the retransmission of the packets lost on the broadcast system and also develop a model for the evaluation of the residual errors in the RFR operations.

Keywords—Mobile TV, cellular networks, network cooperation, data flow, real-time repair, DVB-T2, LTE, CoAP, buffer, discrete Markov chains.

I. INTRODUCTION

WATCHING television on a smartphone is a popular service. If the cellular network provides this service using unicast, it will have to transmit the same flow to each user individually, which is not efficient. In general broadcast-ing networks are preferred for the mass distribution of popular content. A smartphone can decode the broadcast transmission by integrating a dedicated broadcast receiver. However, compared to a fixed receiver, a handheld receiver (i.e., a smart-phone) has a weaker link budget because of the configurational disadvantages and lower antenna gain [1].

The broadcast of the multimedia content to the handheld receivers has been an interesting topic forboth the cellular

networks and the broadcast network standardization bodies. The European Telecommunication Standards Institute (ETSI) proposed Digital Video Broadcast - Terrestrial (DVB-T) in 1997, which was the first digital television standard for terrestrial applications. Soon after its success in the middle of the previous decade ETSI proposed some handheld DVB standards like DVB-Handheld (DVB-H) and DVB-Satellite to Handheld (DVB-SH) [2]. The standards for the hand-held receivers could not succeed because of the lack of a denser deployment of cell sites [3], [4] and the absence of a massive handheld-oriented multimedia market [5]. The state-of-the-art DVB terrestrial standard, i.e., DVB-T2, includes some parameter sets for handheld receiver coverage [6], [7]. The upcoming handheld broadcast standard is DVB-Next Generation Handheld (DVB-NGH), which will be aligned with the DVB-T2 framing structures [8], [9].

Just half a decade ago a mobile TV service was proposed over the best effort unicast bearers in the cellular networks. Since release 6 the 3rd Generation Partnership Project (3GPP) has also been proposing some broadcast services e.g., Multimedia Broadcast Multicast Service (MBMS) [10], [11] for the mobile TV transmission. The recent proposal of 3GPP in this regard is evolved MBMS (eMBMS), which has just begun to see some commercial acceptance.

Meanwhile, the 3GPP and DVB communities have been discussing working together for an efficient mobile TV solution [4]. Such discussions have not been fruitful either. The Mobile Multimedia (M3) Project of l'Agence Nationale de la Recherche (ANR) in France proposes a joint physical layer for the eMBMS and DVB-NGH systems [12]. Similarly, in [13] the authors proposed a concept of Integrated Communication and Broadcast Network (ICBN), which enables an out-of-band interactivity via mobile communication technologies, e.g., 3G and WLAN for broadcast services.

Contrary to the concepts of complete convergence [14] or integration for interactivity, we propose an interworking framework between the broadcast and cellular networks to ensure a better transmission quality for mobile TV users. A similar proposal was presented in [15] introducing redundancy-on-demand mechanism via broadband networks for the broadcast to TV terminals. In our work we propose a real-time repair service by the cellular network for the broadcast data flows received at handheld receivers (smartphones). This service is based on the cellular network and it retransmits the lost packets from a broadcast data flow received by a smartphone.

M. M. Anis was with the Department of Networking, Security and Multimedia, Institut Mines Telecom—Telecom Bretagne, Rennes 35510, France. He is now with the Usman Institute of Technology—Hamdard University, Karachi 75300, Pakistan (e-mail: moizhut@gmail.com).

X. Lagrange is with the Department of Networking, Security and Multimedia, Institut Mines Telecom—Telecom Bretagne/IRISA, France (e-mail: xavier.lagrange@telecom-bretagne.eu).

R. Pyndiah is with the Institut Mines Telecom—Telecom Bretagne, France, and also with LabSTICC, Bretagne, France (e-mail: ramesh.pyndiah@telecom-bretagne.eu).

The broadcast data flows may originate in a DVB network or within the cellular network due to some service like eMBMS.

The retransmission of the missing elements is a classic way to improve the reliability of a non-ideal reception. In a conventional broadcast there is no bidirectional link and therefore it is not possible to trigger a partial or complete retransmission based on feedback. Our analysis in [16] and [17] reveals that significant improvement in the DVB handheld coverage is required. In the case of a smartphone receiving the DVB transmission, a bidirectional link with the cellular network is present. Therefore, this link can be used to retransmit the lost DVB packets to each smartphone on the ground.

In Section II we present the concept of a real-time repair over a broadcast data flow and define our proposal for a Real-time Flow Repair (RFR) service based on the cellular network. In Section III we introduce CoAP, which is a new light client-server application protocol. We also present our argument about the use of CoAP for data-flow repair. Section IV summarizes the DVB-T2 transmission chain and presents a method for the identification of a DVB unit data packet, which is called a Base Band - frame (BB-frame). We also outline the major steps of the RFR service procedures.

In Section V we analyze the available radio resources in the LTE access network for supporting the additional load due to RFR service. In Section VI, we characterize the error performance for a smartphone by analyzing the Round-trip time (RTT) delay values from a measurement campaign in a commercial cellular network and by developing an RFR service error model for the given RFR buffer size. Section VII concludes that with the available resources in the cellular networks, i.e., LTE, the proposal of a real-time repair over TV broadcast to the smartphones is implementable.

II. SERVICE PROPOSAL

A. Context

The method used for a massive distribution of files is called Filecasting, which signifies a file broadcast. The IP networks use File Delivery over Unidirectional Transport (FLUTE) protocol for filecasting [18]–[20]. FLUTE is based on the principle of splitting a file into uniquely identifiable elements. In [21] Hechenleitner proposes an HTTP protocol-based file repair mechanism for DVB-H or IP Data-Casting. In this procedure, each receiver of a broadcasted file undertakes a post-broadcast file repair process. For the elements not received, a GET request is sent to a file repair server via a cellular network or a Wireless Local Area Network (WLAN) connection.

In the literature another well-known scheme for a post-broadcast repair process is to recover the missing elements of a broadcast transmission locally from a remote transmitter. For example in [22] and [23] a peer-to-peer repair approach is considered. In this approach, a data broadcast to several local nodes is considered via a cellular network. The local nodes are physically close and form an 802.11-based adhoc network to cooperatively repair the data reception for each other. There are two bottlenecks for such a repair operation. At first, all the

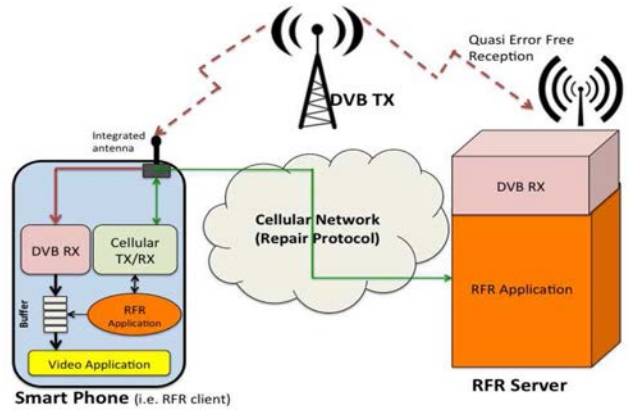

Fig. 1. Simplified architectural layout.

missing elements from the broadcast reception at a given local node may not be sufficiently available from the other local nodes. Moreover, such a distributed repair operation can be slow for a time-constrained streaming application.

B. Real-Time Flow Repair (RFR) Service Definition

A repair operation is fundamentally based on the retransmission of the lost packets in the data reception. In the case of a data flow there are no predefined time boundaries regarding the end of the data transfer. The phenomenon of losing packets is thus an on-going process. Therefore, the repair operation has to be running side by side with the data flow, contrary to a post-data-transfer repair, which is made after the completion of a file reception as considered in [24]. In our work we propose Real-time Flow Repair (RFR) service, which repairs a broadcast data flow to the handheld receivers in real time by using a cellular network.

The RFR service operates between a server and a client, which can be any smartphone. To support an RFR service, a smartphone requires an on-chip DVB receiver, an RFR application and a buffer. We consider a server which is configured for the RFR service, located in any IP network connected to the cellular core network via the internet. We assume that the RFR server can provide any missing DVB packet, whenever an RFR client requests it via cellular network. The RFR server may either have a direct wired link with the DVB network content generation unit or may have a DVB receiver with a roof antenna, which receives the DVB signals at Quasi Error Free (QEF) level. In Fig. 1 we show a DVB flow received by the smartphone using a common antenna for the broadcast and cellular network signals. This kind of antenna is referred to as the integrated antenna in [1].

In our proposal, as soon as the repair service is activated, the DVB flow is buffered before it is forwarded to the video application for play-out in a smartphone. A repair operation is invoked each time the DVB receiver detects an erroneous packet in the DVB flow. The buffer is used to delay the play-out by an amount of time long enough to allow the smartphone to request a retransmission of the missing DVB packet and receive it. The repair service is provided at the expense of an extra but constant delay on the received flow. (see Fig. 2)

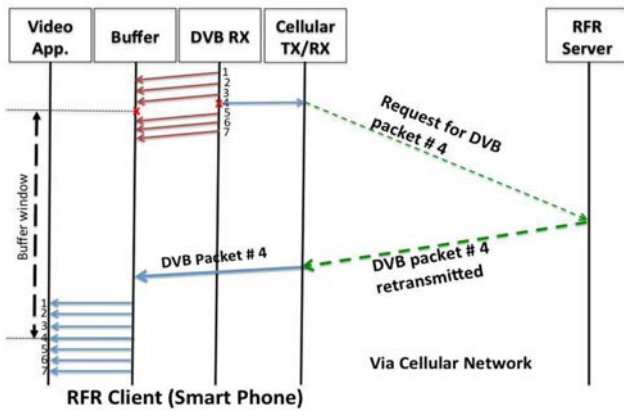

Fig. 2. Simplified timing diagram of an RFR operation.

A real-time repair of a broadcast data flow to the smartphones requires surmounting some challenges:

- 1) The availability of the radio resources in the cellular network.
- 2) The identification of the data units from the broadcast data flow in an RFR server i.e., cellular network.
- 3) A fast retransmission of the lost data units via cellular link, to ensure a real-time repair.
- 4) A buffer large enough to compensate the Round Trip Time (RTT) delay in the cellular network.

III. REAL-TIME REPAIR WITH CONSTRAINED APPLICATION PROTOCOL (COAP)

Most repair processes are based on the Hyper Text Transfer Protocol (HTTP) [21]. HTTP is based on Transmission Control Protocol (TCP) connections. In a post-transfer filecast repair process at the end of file reception, all the missing elements are known. Thus, a file is repaired in a single TCP session. In comparison, a broadcast DVB flow is not time-bounded and the DVB packets may be lost on the fly. There are two possible solutions with TCP-based connections. Either a single TCP session is established for the whole time the smartphone receives the DVB transmission, or a new TCP connection is set up each time a DVB packet is lost.

The first is expensive in terms of signaling at the lower layers of the stack if a cellular network link has to maintain a very long duration TCP connection. The second solution is also expensive because of the additional handshaking signaling for establishing several TCP connections. A cellular network link can be lossy due to high BER and handoffs [25]. Thus the congestion avoidance algorithms in a TCP connection may potentially slow down the proposed cellular network-based repair service. Therefore, instead of HTTP, we use an application protocol based on User Datagram Protocol (UDP), namely the Constrained Application Protocol (CoAP).

A. Introduction to Constrained Application Protocol (CoAP)

CoAP is a client-server transfer protocol proposed to the Internet Engineering Task Force (IETF) for standardization. CoAP is applied to nodes and networks with power and

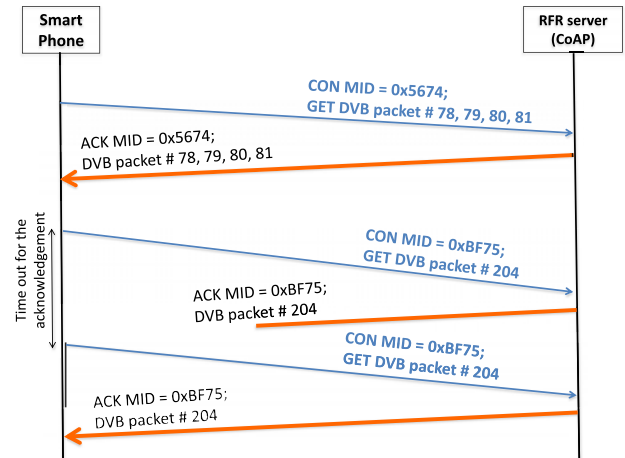

Fig. 3. RFR service via LTE network for a simple implementation of CoAP.

processing constraints [26], [27], like sensor networks. A considerable amount of work on CoAP has already been produced in industry and academia, in the form of building CoAP-based applications and the exchange of practical experiences [28].

CoAP is based on UDP, which makes it remarkably lighter than the TCP-based HTTP. It supports some basic HTTP functions like GET and PUT, as well as other functionalities like resource discovery and multicast [29], [30].

There are four types of CoAP messages:

- ◇ Confirmable message (CON): the sender of a CON message always waits for an acknowledgement from the receiver until a defined timeout. A sender retransmits a CON message if it does not receive an acknowledgement within the timeout period. The number of such retransmission attempts is also configurable.
- ◇ Non-confirmable message (NON): for NON messages, a receiver does not need to acknowledge the reception of the message.
- ◇ Acknowledgement message (ACK): an ACK message carries the acknowledgement and the answer to the request if it is available. For example, if a CoAP client sends a request for a packet in a confirmable message, then the requested data packet will be attached to the ACK message by the CoAP server.
- ◇ Reset message (RST): an RST message is used when the receiver is not able to read the received message.

In the header of a CoAP message there is a 16-bit field called Message ID (MID), which uniquely identifies a confirmable and a non-confirmable message. The acknowledgement messages are related to their corresponding confirmable messages through MID. Similarly, the reset messages are also related to their corresponding Confirmable or Non-confirmable messages through MID.

The real-time repair of the data flow can be very simply implemented with CoAP. When a DVB packet is not correctly received, the smartphone sends a retransmission GET request in confirmable messages. For each request the RFR server sends the requested DVB packet in the acknowledgement message. An illustration of the RFR service working for a simple implementation of CoAP can be seen in Fig. 3. In case consecutive packets are lost, the repair request for several packets

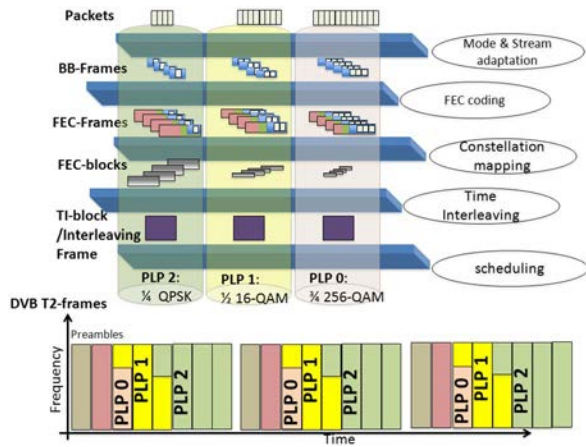

Fig. 4. DVB-T2 transmission chain.

can be put in the same CoAP message. The efficiency of the protocol is then higher because several requests and several packets can be grouped in the same transmission. In [31] authors designed a middleware to study the performance of CoAP in terms of end-to-end delay for a Wireless Sensor Networks scenario. Experimental results reveal that CoAP's delay performance is good specifically at higher loss rates.

IV. IDENTIFICATION OF THE DVB UNIT DATA PACKET

The DVB network is a stream-oriented transmission system and does not include an identification of each specific information block. In this section, we study the DVB-T2 packet structure with a focus on the baseband frame (BB-frame), which can be seen as an information block. We then propose a scheme for the identification of BB-frames and outline the routine procedures for the proposed RFR service.

A. DVB-T2 Packet Structures

A DVB-T2 system transports all kinds of streams or IP packet flows in the form of a specific data unit block called BB-frame. A BB-frame typically includes several video blocks or one or several IP packets. The BB-frame is protected by a Forward Error Correction (FEC), mapped on a modulation constellation, and then interleaved before transmission (see Fig. 4).

Multiplexing in DVB-T2 is a combination of Orthogonal Frequency Division Multiple Access (OFDMA) and Time Division Multiple Access (TDMA). The transmission is based on a periodic frame, called T2-frames [32], which is the basic scheduling unit. A T2-frame is a set of successive OFDMA data symbols that starts by two preambles, which are highly protected and mainly carry the configuration of the frame and the system information. The duration of the T2-frame is a configuration parameter. The maximum value is 250 ms. In our work we consider a 200-ms duration as mentioned in [33].

It is possible to combine different transmission schemes with the concept of Physical Layer Pipe (PLP). A PLP has a specific time interleaving setting, a given modulation and FEC coding rate, which determine the robustness of that PLP. There can be several different PLPs carrying the same content with different qualities, intended to be received by various

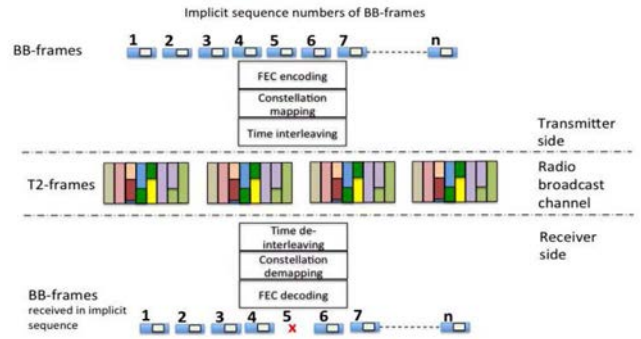

Fig. 5. BB-frames sequence order prior to the followed transformation.

types of receivers. For example, a PLP with a low-order modulation and low code rate is robust and it is transmitted for the handheld receivers with standard definition, whereas another PLP may carry the higher order modulation version of the same logical flow for the fixed receivers with high definition. (see Fig. 4)

A logical structure containing one or several T2-frames (which is specific for a given PLP) is called an interleaving frame. Due to interleaving a BB-frame may span over several T2-frames but should be in the same interleaving frame i.e., there is always an integer number of BB-frames per interleaving frame. On the other hand a superframe is a physical structure which may comprise at maximum 255 T2-frames, but generally it comprises two T2-frames [33]. According to [34] there should always be an integer number of interleaving frames per superframe. Thus a BB-frame is definitely present in a specific interleaving frame (of a PLP) in a specific superframe.

The T2-frame preambles include configurable and the dynamic parts. A change in the configuration may only occur at the end of a superframe. While the dynamic part of signaling changes for each T2-frame. The important fields in the configurable part are:

- NETWORK_ID: a 16-bit field which is associated with the DVB network. It is unique within the geographical region defined by a Country Code (e.g., 250 for France and 840 for U.S.).
- T2_SYS_ID: a 16-bit field in the preambles which identifies a T2-system.
- CELL_ID: a 16-bit field, which carries the ID of the DVB cell from where the relevant stream originates. It is used to differentiate the PLPs carrying the local content.
- PLP_ID: an 8-bit field carrying the unique identification of a PLP in a T2-system.

The dynamic field useful for a BB-frame identification is:

- FRAME_IDX: an 8-bit field in the dynamic part of the preambles, it maintains the index of a T2-frame in a superframe. This field increments by one in every T2-frame and resets when a new superframe starts.

B. BB-Frame Identification for the RFR Service

When the receiver finishes reading an interleaving frame, the DVB decoder obtains an ordered sequence of BB-frames. In Fig. 5 the BB-frames can be seen in the ordered sequence

TABLE I
RFR EXCHANGES: RFR CLIENT TO RFR SERVER

Message Type	Sent	Received
Subscription	NW_ID, T2_Sys_ID, Cell_ID	User_ID, Security token
Service Announcement	-	RFR server IP address, service schedule
Service Activation	User_ID, Security key	activation acknowledgement
Session start / close	PLP_ID	session start / close acknowledgement
GET Request	SF_COUNT / Frame_IDX / ISN	acknowledgment + BB-frame

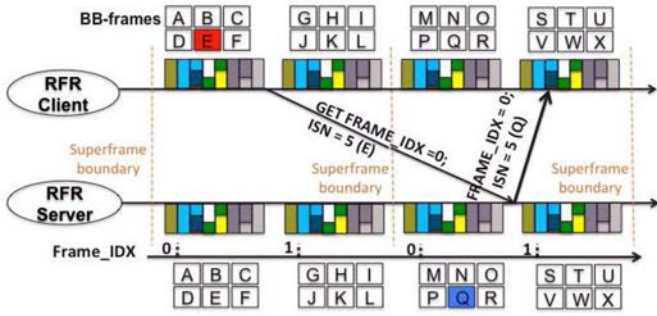

Fig. 6. Ambiguous identification of BB-frame due to large cellular transmission delay.

prior to FEC encoding at the transmitter side and after the FEC decoding at the receiver side. The proposed repair operation preserves the natural order of the BB-frames' sequence in each interleaving frame by assigning an Implicit Sequence Number (ISN). Thus, we identify each BB-frame within an interleaving frame by its ISN.

A BB-frame is associated with a unique PLP and for each PLP the indices of all the T2-frames carrying the PLP are known. We propose to identify each interleaving frame by the index value (FRAME_IDX) of the first T2-frame of the interleaving frame.

The superframes of a DVB transmission do not have any index. A typical cellular link poses an RTT delay in hundreds of ms if used after a period of inactivity. Thus, a retransmitted BB-frame may arrive at the smartphone when it is receiving the BB-frames from the succeeding superframe.

It is shown in Fig. 6 that a BB-frame E (i.e., ISN = 5), is lost in a given superframe and the RFR service makes a request for the retransmission of ISN = 5. If this request arrives at a time when the succeeding superframe is being received, then the RFR server will retransmit BB-frame Q against the request for ISN = 5. Thus we propose a superframe counter (SF_COUNT) for the unique identification of each retransmitted BB-frame. The SF_COUNT is maintained by both ends (i.e., at the client side and at the server side). A synchronization procedure is also defined to ensure that both ends have the same value of SF_COUNT for a given superframe (refer to Section IV-C5). Once synchronization is achieved

then the SF_COUNT is incremented at both ends each time the FRAME_IDX field is reset.

Hence, to identify a BB-frame we first identify a PLP by using the following fields from the DVB-T2 signaling data: PLP_ID, T2_SYS_ID, NETWORK_ID and CELL_ID. Then to identify a BB-frame from an already identified PLP we propose that the following be used:

- Identification of the superframe using SF_COUNT
- Identification of the first T2-frame of the interleaving frame using FRAME_IDX
- Identification of a BB-frame within an interleaving frame using ISN.

C. Specification of the RFR Service Procedures

We define an RFR service to comprise the following procedural steps: (see also Table I)

1) *Subscription*: Subscription is the first step in starting a relationship between a service provider and a subscriber. A client shares his global location coordinates to get subscribed to the service. The service provider or operator determines the relevant NETWORK_ID, CELL_ID and T2_SYS_ID, depending on the location coordinates of the user. The service provider saves this information in a database against a User ID. The User ID and a security token are provided to the subscriber, and are used together in the service activation process.

2) *Service Announcement*: A service announcement contains details about service access, e.g., the IP address of the RFR Server and the availability schedule of the service, etc. There can be several different ways to disseminate service announcements to both subscribers and non-subscribers. For instance, service announcements can be made using Short Message Service (SMS) broadcast or web-based announcements on a Uniform Resource Locator (URL), which can be browsed.

3) *Service Activation*: At the time when a smartphone starts receiving the DVB transmission, the RFR application in the smartphone sends a service activation request to the RFR server. The RFR application generates a security key by using the registered User ID and the security token provided at the time of subscription. A service activation request includes the

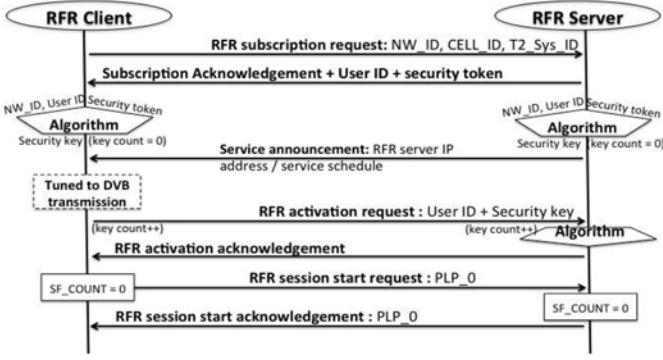

Fig. 7. Major steps prior to repair operation.

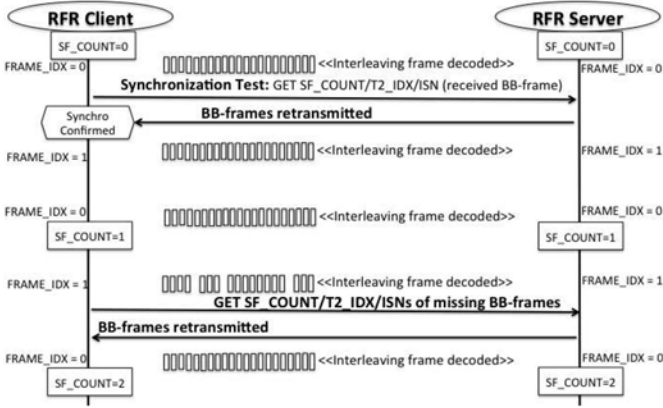

Fig. 8. Repair operations along with the broadcast data flow.

User ID and the security key. The transferred security key is verified, to authenticate and approve the availability of the service for the user. After verification, the RFR server sends an acknowledgement of the service activation.

4) *RFR Session*: Once the smartphone receives an acknowledgement of service activation, the RFR application triggers the smartphone to make a request for the start of an RFR Session. Each RFR session is specific to a particular PLP. Therefore, an RFR session start request includes the PLP ID of the PLP through which the smartphone is receiving data. The RFR server sends back an acknowledgement of the session start request, which confirms that the RFR server is ready to serve any request from the smartphone (see Fig. 7).

During an RFR session, the RFR client and the server maintain the SF_COUNT. The SF_COUNT is reset at the start of an RFR session and is incremented every time the FRAME_IDX is reset during the session.

In an RFR session, each time the DVB receiver finishes decoding an interleaving frame, it acquires the implicit sequence numbers (ISNs) of all the BB-frames within the decoded interleaving frame. If one or more BB-frames are lost, the RFR application requests their retransmission. As shown in Fig. 8, the retransmission request includes the SF_COUNT value, the relevant FRAME_IDX and a list of the lost BB-frames' ISNs i.e., SF_COUNT/ FRAME_IDX/ISNs.

5) *SF_COUNT Synchronization Test*: As explained above, the SF_COUNT is maintained on both sides i.e., the client and the server. At the time of the RFR session start request,

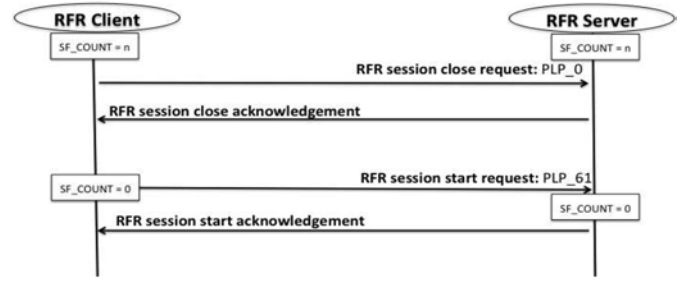

Fig. 9. PLP switching.

the SF_COUNT is reset by the client side. The RFR server resets the SF_COUNT only after receiving the RFR session start request. The RFR server and the RFR client are tuned to the real-time DVB transmission flow. The SF_COUNT field is incremented each time FRAME_IDX is reset. In the worst case scenario, if the uplink transmission delay in the LTE network is longer than the T2-frame duration (i.e., typically 200 ms), then the SF_COUNT at the RFR server will be desynchronized from the RFR client.

In order to verify the synchronization, the RFR client sends a GET request for a correctly received BB-frame, immediately after having received the session start acknowledgement. The RFR server retransmits the requested BB-frame via LTE network in response to the test GET request. The synchronization between the client and server is confirmed if the retransmitted BB-frame is the same as the one requested. In the case of detecting a desynchronization, the RFR session can be started again for the same PLP.

6) *RFR Session Change*: If a smartphone switches to a different DVB service or starts getting a low data rate version of the same DVB service, it has to switch to a new PLP. In order to do so, the RFR application in the smartphone makes a session close request for the current PLP. As the session closure is acknowledged, the RFR application in the smartphone requests a new RFR session for repairing the newly switched PLP. In Fig. 9, the RFR application is shown closing an RFR session for PLP_0. After receiving a session closure acknowledgement, it starts an RFR session for PLP_61. It can be noticed that at the start of a new session, the SF_COUNT is reset.

V. DVB-T2 TRANSMISSION LOAD OVER LTE NETWORK

In this section we model the relationships between the DVB transmission power, the load over the LTE network and the inter-site distance in the LTE network. We evaluate the additional load over the LTE network through an approximate error performance model for the DVB-T2 packet flows. Then we analyze that load in terms of the fundamental resource and time allocation units in the LTE network.

A. Load Evaluation

We use sigmoidal curve-fits over the simulated plots of Bit Error Rate (BER) vs SINR for DVB-T2. The simulation results are considered for a Typical Urban - 6 taps (TU-6) channel

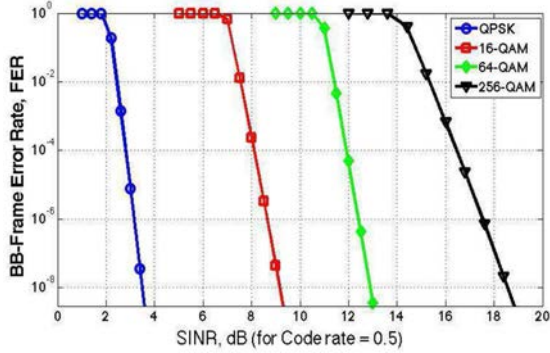

Fig. 10. FER performance curves for DVB-T2 data signals.

TABLE II
VALUES FOR THE PARAMETERS OF THE BER MODEL

Modulation Coding Scheme	a_1	a_2	a_3
1/2 QPSK	-0.67	-9.2	16.2
1/2 16QAM	-0.27	-3.94	34.75
1/2 64QAM	-0.27	-2.76	56.37
1/2 256QAM	-0.082	-1.51	32.18

condition from [35]. The function we use to get the BER is,

$$f(\gamma) = 1 - \frac{1}{1 + e^{a_1(\gamma)^2 + a_2(\gamma) + a_3}}, \quad (1)$$

where γ is the SINR value and a_1 , a_2 & a_3 are the fitting parameters. The values of these parameters depend on the choice of the simulated set-up for a particular modulation and coding scheme. The values of the parameters are chosen to get the minimum value of the sum of squared logarithmic differences. Mathematically, we have a fitting metric, $\Delta = \sum_{i=1}^p (\log f(\gamma_i) - \log BER_i)^2$, where the BER_i is the simulated i^{th} value for SINR γ_i . In [36] and [37] authors used a similar approach to develop error performance models for the FEC-coded links in fading channels.

The FEC scheme for DVB-T2 consists of a Low-Density Parity Check (LDPC) code concatenated with a Bose Chaudhry and Hocquenghem (BCH) Code. The LDPC code serves as the inner code, which determines the code rate for the FEC coding chain. The BCH code is the outer code. Our scheme takes into account the BB-frames in error, therefore for a BCH code with hamming distance, d_h , and b_{fr} bits per BB-frame, the Frame Error Rate, FER , can be approximated as,

$$FER = BER \frac{b_{fr}}{d_h} \quad (2)$$

For a detailed discussion related to this approximation, we refer the reader to [38]. In Fig. 10, we plot the FER vs SINR curve using the model in (1) for different values of the parameters with the FER approximation in (2). The parametric values used for a_1 , a_2 and a_3 are presented in Table II.

For this analysis we choose all parameters compliant with the T2-lite profile of DVB-T2 [1], [32]. A code rate of 0.5 for a short FEC frame has a BB-frame $b_{fr} = 7032$

bits long [34], [39]. We consider a source data-flow rate, $r_{user} = 0.512$ Mbps [40], which is equivalent to 73 BB-frames per second.

For a given SINR of the DVB signal we can evaluate the BER using the model in (1), for which we approximate the BB-frame Error Rate (FER). Multiplying the FER for each user by $\frac{r_{user}}{b_{fr}}$, we get the number of erroneous BB-frames to be retransmitted by the LTE network. The retransmissions of BB-frames summed for all the users in an LTE cell gives the overall retransmission BB-frames per second per eNode B, L_{eNB} .

$$L_{eNB} = \frac{r_{user}}{b_{fr}} \sum_{i=1 \rightarrow n_{percell}} FER_i, \quad (3)$$

where, $n_{percell}$ is the number of users per LTE cell and FER_i is the FER experienced by the i^{th} handheld receiver.

B. Number of the Pairs of Resource Blocks

In [41] the authors introduced Bandwidth Efficiency and SINR efficiency in the Shannon formula to fit it for several simulated LTE systems. We have considered the link-level fit for a SISO (1x1) Downlink antenna configuration, TU-6 channel and Round Robin-based packet scheduler. For the i^{th} handheld receiver, the spectral efficiency, S_i , as a function of SINR is given as,

$$S_i = 0.56 \log_2(1 + \gamma_i/2) \quad (4)$$

where γ_i is the SINR received by the i^{th} handheld receiver in the LTE access network.

For the LTE networks resource allocation is based on the number of Pairs of Resource Blocks (PRBs). A PRB spreads over one Transmission Time Interval (TTI) in the time domain, $t_{TTI} = 1$ ms. In the frequency domain it comprises six sub-carriers, each being 15kHz wide. A PRB has a bandwidth of $B_{PRB} = 0.180$ MHz [42]. The capacity of an LTE network is measured in terms of the maximum number of PRBs per TTI. We consider an LTE system with a bandwidth of 10 MHz, i.e., 50 PRBs per TTI.

The number of bits carried by each PRB in a TTI depends on the spectral efficiency available. From (3) the total number of bits per second to be retransmitted by the LTE network for the i^{th} user is $r_{user} \cdot FER_i$. If the total number of bits per second obtained for the i^{th} user is divided by its spectral efficiency S_i from (4), we find the bandwidth required by the i^{th} user for the retransmission of missing BB-frames as $r_{user} \cdot \frac{FER_i}{S_i}$. Hence, the number of PRBs required by an eNodeB per TTI, for the retransmission of the missing BB-frames to $n_{percell}$ users in the LTE cell, can be given as,

$$PRB_{eNB} = r_{user} \sum_{i=1 \rightarrow n_{percell}} \frac{FER_i}{B_{PRB} S_i}. \quad (5)$$

C. Simulation Results

In the simulations we consider uniformly distributed handheld receivers in some geographical location with the double coverage of DVB-T2 and LTE networks. We consider the

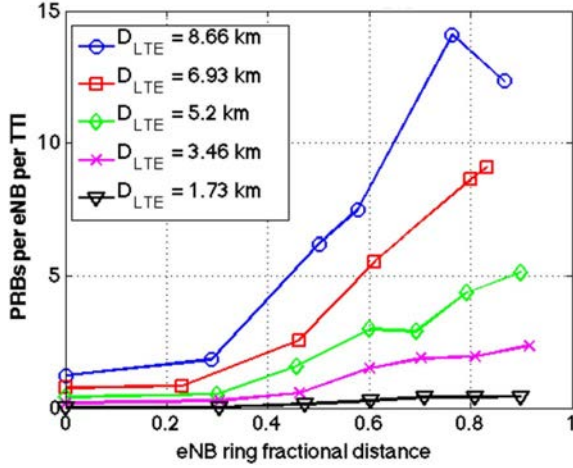

Fig. 11. PRBs per eNB per TTI vs fractional distance in DVB central cell, for DVB Tx power = 68 dBm.

global population density for the geographical location considered i.e., 100 per sq. km. We assume 2% of the people use RFR service at a time and that these users are equally divided among four different operators providing the mentioned service. Thus, there is only one subscriber every 2 sq. kms. The choice of LTE and DVB network parameters and other details about the simulation scenario can be found in [39].

The simulation results show that the available LTE capacity can potentially support the RFR service for the DVB-T2 flows. In our simulations we observe the effect on the per cell loading of the LTE network. We observe this additional traffic load in terms of the number of PRBs per TTI. We consider the traffic load per eNode B for different Inter-Site Distances (ISDs) in the LTE access network.

In Fig. 11 we plot the LTE loading against the fractional distance of the eNB from the central DVB transmitter for different ISDs. The fractional distance of an eNB is defined as a ratio of the radial distance of the eNB with the central DVB transmitter to the circular radius of the central DVB cell.

We consider the transmission power equal to 68 dBm which is a typical value for DVB networks. It can be observed that for a large LTE cell like $ISD = 8.66$ km, it requires a maximum of 14 PRBs per TTI from each eNode B, which corresponds to 28% of the available LTE capacity i.e., 50 PRBs per TTI. Terminals in cells close to the DVB-T2 transmitter have a very good reception and the additional load is very low. Thanks to Single Frequency Network (SFN) transmission, terminals at the border of DVB cell can combine the signal from several DVB transmitters and the additional load is moderate. Thus the load is not always an increasing function of the fractional distance.

In Fig. 12, we plot the average load per eNodeB against the ISD in LTE network. It can be seen that the average additional percentage load per eNodeB due to RFR service is below 16% for the largest ISD considered i.e., $ISD = 8.66$ km. The results presented in Figs. 11 and 12 are obtained for a population density of 100 inhabitants per sq-km but can be generalized to any density ρ . The additional load for a given eNodeB is proportional to both ρ and the area of the cell and hence to $1/D^2$, where D is the ISD. In other words, the additional load

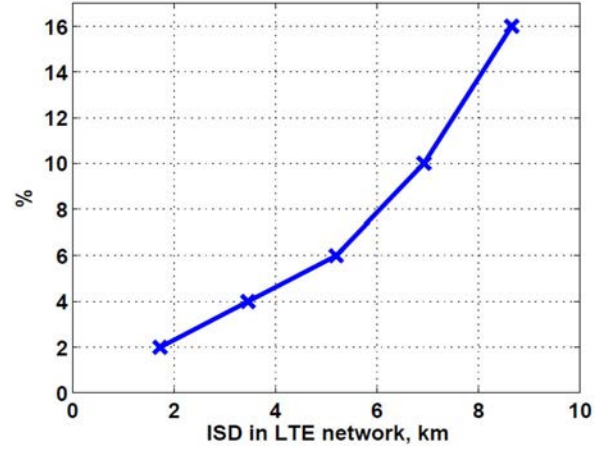

Fig. 12. Average additional load per eNB for 100 inhabitants per sq-km.

is the same for all couples $(k\rho, D/\sqrt{k})$ for any value of k . Typically small ISDs are preferred to cover a high population density area. In Table III the max load increase and the average load increase have been summarized and presented against ISD values considered in our simulations.

We considered the coverage for the entire DVB cell, which is large compared to LTE cells. We need a large number of LTE cells to cover the same geographical area by the LTE network. To keep a lower computational load, we restricted our simulations to an ISD as low as 1.73 km for the LTE network. For $ISD = 1.73$ km, the per eNode B load is already 2% of the available capacity. Typically, the LTE cell sizes are much smaller than those considered in the simulations. According to [42] for the typical macrocells $ISD = 1.73$ km, additionally there are even smaller LTE cells like femto cells, with an ISD as low as 60 m such that $(100, 1.73)$ is equivalent to $(83137, 0.06)$. Thus, we infer that the LTE network has enough resources to support the RFR service for a DVB-T2 network.

VI. RESIDUAL ERROR FOR AN RFR CLIENT

A. Connected State vs Idle State for a Cellular Terminal

In this analysis we assume the cellular network only offering RFR service to smartphones which are already receiving the TV transmission from a DVB network.

Regarding the radio connection in cellular networks, there are two fundamental states for a terminal. When there is an active data flow (upstream or downstream), the terminal is in *connected state* (ECM-connected, in the LTE vocabulary). It has a short radio identifier, which is allocated by the network. Generally, a periodic handshake is made so that the network can check the terminal is still in the same cell. When there is no flow, the terminal is in *idle state* (ECM-idle, in the LTE vocabulary). The terminal mainly decodes a few specific channels as synchronization and broadcast channels from time to time. Due to the radio identifier allocation procedure and the associated security procedures, the RTT delay is much longer in idle state compared to connected state. We thus analyze the delay in idle state in the following section.

TABLE III
ADDITIONAL LOAD IN LTE NETWORK FOR POPULATION DENSITY OF 100 INHABITANTS PER SQ-KM

ISD, km	Load increment		Equivalent couples i.e. (Density, ISD)			
	Average	Maximum				
8.66	16%	28%	(160, 6.93),	(280, 5.2),	(630, 3.46),	(2506, 1.73)
6.93	10%	20%	(64, 8.66),	(180, 5.2),	(400, 3.46),	(1600, 1.73)
5.2	6%	12%	(36, 8.66),	(56, 6.93),	(225, 3.46),	(904, 1.73)
3.46	4%	6%	(16, 8.66),	(25, 6.93),	(45, 5.2),	(400, 1.73)
1.73	2%	4%	(4, 8.66),	(7, 6.93),	(12, 5.2),	(25, 3.46)

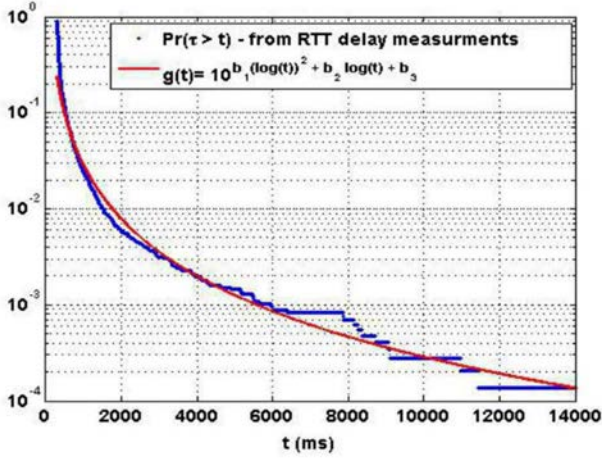

Fig. 13. CCDF of the RTT-delay values in a commercial 3G network.

The connected state is maintained until an inactivity timer is timed out with reference to the latest data transmission. The terminal goes back to the idle state once this timer is timed out. In the analysis, the initial value of the inactivity timer is called T_{con} . Without loss of generality, we assume the inactivity timer is a multiple of the T2-frame duration and we define,

$$n = T_{con}/T_2, \quad (6)$$

where T_2 is the T2-frame duration (see Fig. 4).

B. Round Trip Time (RTT) Delay Measurement Campaign in a 3G Network

We performed some basic tests in a commercial 3G network to record the RTT delays. For this purpose we used the ping command [43] on a 3G cellular link. We recorded RTT delays for 14, 500 pings via 3G network to the closest responding IP address with respect to smartphone. We considered a long time interval between every two ping requests in order to determine the RTT when the terminal is in the idle state. The complementary cumulative distribution function (CCDF) of the measured RTT is shown in Fig. 13. We propose an analytical formula for the CCDF of the RTT:

$$g(t) = 10^{b_1(\log(t))^2 + b_2 \log(t) + b_3}, \quad (7)$$

where b_1 , b_2 and b_3 are the fitting parameters, which are found to be -0.1874, -0.7057 and 2.2334 respectively. These fitting parameters were determined to get the minimum mean

value of the squared logarithmic differences, mathematically, $\frac{1}{n} \sum_{i=1}^n (\log(g(t_i)) - \log(\Pr(\tau > t_i)))^2$.

From the measurements and (7), it can be seen that the probability of having an RTT delay value longer than the typical interleaving frame duration (i.e., 400 ms) is close to 10%. This justifies the necessity of the synchronization procedure and the management of the SF_COUNT counter described in Sections IV-B and IV-C5.

Furthermore, it can be noted that the RTT delay can be larger than 1 second in 3G networks as opposed to LTE 4G networks, which were originally designed to guarantee very short latency (typically 50 ms). Hence, we consider the 3G case in the delay analysis, which is a worse case.

C. Failure Probability of the Repair Process

The RFR service is based on a buffer in the terminal as shown in Fig. 1. The buffer delays the playout of the mobile TV transmission in the smartphone. Let T_{buf} be the delay generated by the buffer. This delay is necessary to desensitize the TV watcher from the delay of an RFR operation. If a BB-frame that is not correctly received on the DVB-T2 channel is retransmitted through the cellular network within T_{buf} , the repair operation is fully transparent to the user. If it is received after T_{buf} or if it is not received, the repair operation fails. If we assume a good level of coverage by the cellular network and a retransmission protocol (i.e., Automatic Repeat request protocol) in the cellular network, then there is no major loss on the cellular side. The failure probability of the repair process is simply $g(T_{buf})$.

D. Presentation of the Model

Because of the shadowing effect and more generally the variation of the propagation environment, the channel cannot be considered as Gaussian. We thus consider a Gilbert-Elliot model with two states of average duration $T_G \geq 0$ (for Good) and $T_B > 0$ (for Bad). A DVB channel is in good condition when the DVB transmission is received at the QEF level. Hence, we assume all BB-frames are correctly received. In a bad condition the BB-frame error probability P_1 is a function of the SINR and is computed with (1) and (2). When the state of the terminal, the inactivity timer and the reception of the DVB flow are all considered, an RFR client can be in three states, as shown in Fig. 14.

We model the behavior of a handheld terminal with a discrete time system where any state change takes place only at the end of a T2-frame. In other words, we consider a slotted

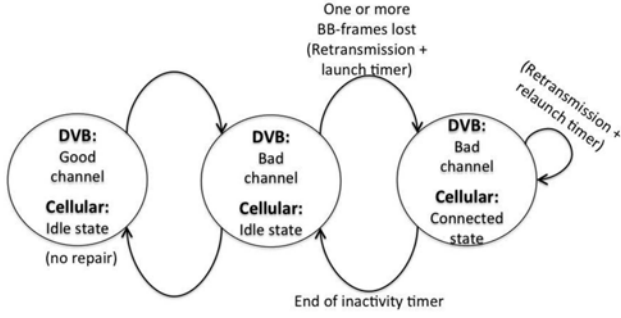

Fig. 14. DVB channel vs cellular link state diagram.

system where the T2-frame is the basic slot. In the following when we refer to a slot, it should be understood as a T2-frame. This approximation is valid when $T_B, T_G \gg T_2$ (or if $T_G = 0$). The equivalent discrete Gilbert-Elliot model is characterized by two transition probabilities α and β defined as

$$\alpha = 1 - e^{-T_2/T_G} \quad (8)$$

$$\beta = \begin{cases} 1 - e^{-T_2/T_B} & \text{if } T_G \neq 0 \\ 0 & \text{if } T_G = 0 \end{cases} \quad (9)$$

When there is a repair request sent by the terminal, it switches to the connected state. If there is no other repair request during T_{con} or equivalently during n slots, the terminal goes back to the idle state. As soon as there is a repair request, the timer is reset and the terminal stays in the connected state for at least n slots. The system can then be described by a discrete-time Markov chain with $n + 2$ states:

- State G where the DVB channel has good transmission condition
- State B_0 where the DVB channel has bad transmission condition and the terminal is in idle state regarding the cellular radio connection
- State B_i where the DVB channel has bad transmission condition and the terminal is in connected state. Index i is the number of slots before the timer expires (in case there is no other repair).

Note we assume the terminal always goes back to idle state as soon as the channel becomes good. This represents a worst case scenario. The inactivity timer can still be active when the channel becomes bad again if the duration in good state is very short. In that case, the terminal is in connected state, the RTT on the cellular network is very small and the repair process is always successful, as opposed to our model, which considers the terminal is in idle mode.

A terminal should generally decode several BB-frames in the same slot (i.e., the same T2-frame). Let N be the number of BB-frames in a slot. If at least one BB-frame is lost, the RFR client sends an RFR repair request to the cellular network. The probability of using the repair service in one slot is then $1 - (1 - P_1)^N$ if the DVB channel is still in bad state at the end of the slot. The probability δ of the inactivity timer getting reset is thus,

$$\delta = (1 - \beta)(1 - (1 - P_1)^N). \quad (10)$$

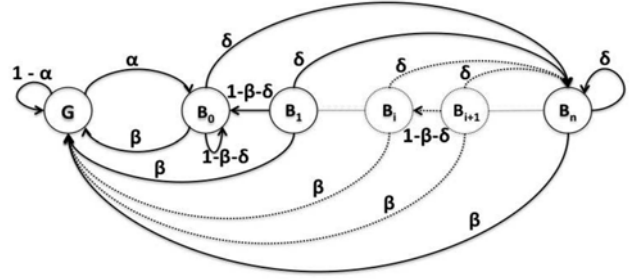

Fig. 15. Discrete Markov chain representation of the RFR service.

TABLE IV
VALUES OF THE PARAMETERS FOR THE PERFORMANCE ANALYSIS

Parameter	Values	Comments
T_G	0 s, 10 s, 30 s	-
T_B	10 s, 30 s	-
T_{con}	5 s	measured for a 3G network
T_2	0.2 s	Typical value, max 0.25 s
T_{buf}	2 - 6 s	-

If the DVB channel is in bad state, whatever the value of the inactivity timer, the probability that the DVB channel goes to the good state is β . When the timer is active (states B_i , i with $i > 0$), the value of the timer is just decremented if there is no repair request and if the DVB channel remains in bad state. The transition probability from state B_i to state B_{i-1} is then $1 - \beta - \delta$. The Markov chain with all transitions is shown in Fig. 15 and the associated transition rate matrix is given in (11).

The stationary distribution of this chain is thus determined by solving:

$$\begin{cases} \Pi Q = \Pi \\ \Pi \mathbf{1} = 1 \end{cases} \quad (12)$$

where $\Pi = [\pi_G \ \pi_{B,0} \ \dots \ \pi_{B,i} \ \dots \ \pi_{B,n}]$ is the steady state probability vector and $\mathbf{1} = \text{transpose of } [1 \ 1 \ \dots \ 1]$.

After a few computation steps, it can be found as in (13).

$$\begin{cases} \pi_G = \frac{\beta}{\alpha + \beta} \\ \pi_{B,0} = \frac{\alpha}{(\alpha + \beta)(\beta + \delta)} [\beta + \delta(1 - \beta - \delta)^n] \\ \pi_{B,i} = \frac{\delta \alpha}{(\alpha + \beta)} (1 - \beta - \delta)^{n-i} \\ \text{for } 0 < i < n \end{cases} \quad (13)$$

The repair process occurs only when the DVB channel is bad and when at least one BB-frame is not correctly received in a T2-frame. It fails if the terminal is in idle mode (i.e., in state $(B, 0)$) and if the RTT is larger than the buffer delay T_{buf} . Hence,

$$FER_{RFR} = \pi_{B,0} g(T_{buf}) \delta \quad (14)$$

where $g(T_{buf})$ is given by (7).

E. Results and Analysis

We analyze the performance of the repair service for a typical configuration shown in Table IV. In Fig. 16 we plot the

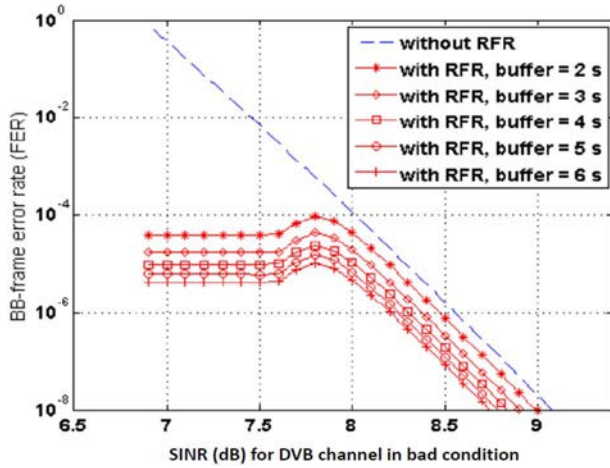

Fig. 16. FER with and without RFR service for $T_G = 10$ s & $T_B = 30$ s.

residual FER for an RFR client when the RFR service is activated, against the SINR for different buffer durations, and compare it with the FER rate in the bad DVB channel conditions without any repair. It can be observed that the residual FER is bounded by a maximum value, which is 10^{-4} for a 2-second buffer. For a low level of SINR the residual FER is very low because the frequency of BB-frame retransmission requests is high, which keeps the RFR client in connected state except after the terminal has experienced good DVB channel conditions. With the increase of the SINR value, the repair process tends to be requested less often. Hence, the probability that the terminal is in idle state when sending a repair request increases, which raises the residual FER value. For high SINR, the repair process is only used exceptionally and the residual FER decreases with the SINR.

The larger the buffer time (or equivalent length), the smaller the residual FER for a given SINR of the DVB channel. This relationship can be used to establish a trade off between the available memory resources and the intended mobile TV transmission QoS. If we consider a 10^{-4} FER as a comfort level, then a 2-second buffer is enough, requiring 128 KBytes of buffer memory.

In Fig. 17, we consider a 2-second buffer but different values of T_G and T_B to plot the residual FER on the DVB channel for an RFR client. Each one of the four curves has three zones of SINR values: peak-FER SINR values, lower SINR values and higher SINR values. For the curves $T_G \neq 0$, even for the lower SINR values there is some probability of attaining idle state, therefore the residual FER remains constant for all the

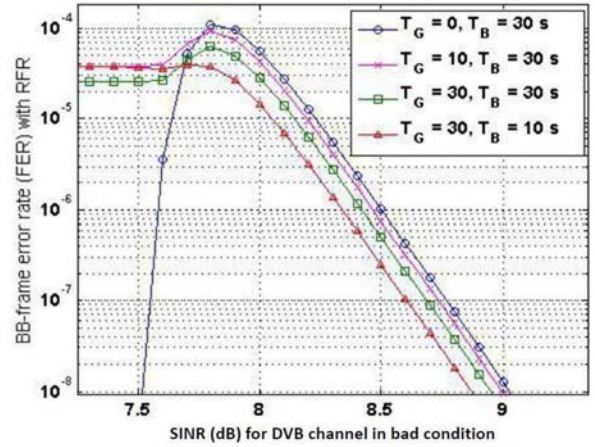

Fig. 17. FER with RFR service for different T_G & T_B values for $T_{buf} = 2$ s.

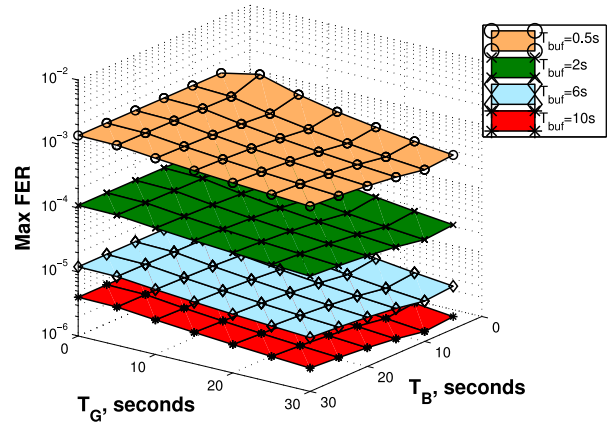

Fig. 18. Maximum FER surfaces for different values of T_G & T_B and T_{buf} .

values of SINR in this zone. For the lower SINR values with $T_G = 0$, the terminal always remains in the connected state, which enables RTT delays that are almost 10 times shorter. Thus, the repair operation never fails and the residual FER for an RFR client is very low. For the peak-FER and higher SINR values, the higher the T_G/T_B , the lower the residual FER. Note that $T_G = 0$ is the worst case with the residual FER slightly above 10^{-4} .

In Fig. 16 it can be observed that there is a maximum FER value for all of the FER-curves against the average SNR. We thus show in Fig. 18 several surface plots in which the

$$Q = \begin{bmatrix} 1-\alpha & \alpha & 0 & \dots & 0 & 0 & \dots & 0 & 0 & 0 \\ \beta & 1-\beta-\delta & 0 & \dots & 0 & 0 & \dots & 0 & 0 & \delta \\ \beta & 1-\beta-\delta & 0 & \dots & 0 & 0 & \dots & 0 & 0 & \delta \\ \vdots & \vdots & \vdots & \ddots & \vdots & \vdots & \ddots & \vdots & \vdots & \vdots \\ \beta & 0 & 0 & \dots & 1-\beta-\delta & 0 & \dots & 0 & 0 & \delta \\ \vdots & \vdots & \vdots & \ddots & \vdots & \vdots & \ddots & \vdots & \vdots & \vdots \\ \beta & 0 & 0 & \dots & 0 & 0 & \dots & 1-\beta-\delta & 0 & \delta \\ \beta & 0 & 0 & \dots & 0 & 0 & \dots & 0 & 1-\beta-\delta & \delta \end{bmatrix} \quad (11)$$

maximum FER values are considered against several combinations of the T_G and T_B values of the Gilbert-Elliot model. Each surface corresponds to one of the considered values of T_{buf} . For the sake of a clear plot we restrict the T_G and T_B values from 0 to 30 seconds. However, similar surface plots were observed for the large values of T_G and T_B . It can be concluded that with a buffer size of 2 seconds the proposed RFR service can restrict the maximum residual-FER to a value of 10^{-4} in almost all conditions.

VII. CONCLUSION

The broadcast of a mobile TV transmission to smartphones is expected to gain more importance in the future. This is especially at a time when the standardization bodies are putting joint efforts to dimension the future of broadcast TV in an era which belongs to smartphones and high-capacity cellular networks. Broadcasting is the most efficient way for the mass distribution of popular content. The unidirectional nature of TV broadcasting does not permit any quality control.

The degradation of the broadcast quality is worse in handheld receivers. Therefore, we propose a real-time repair over the broadcast data flows to smartphones. In this paper we address the following: the indexing and identification of a DVB packet, the possibility of its fast retransmission via cellular network and the modeling of RTT delay in a cellular network for RFR buffer dimensioning. The calculated on-chip buffer dimensions are already small for a 3G network example, and these dimensions will be even smaller for the LTE network. A real-time flow repair service is possible thanks to a light application protocol, i.e., CoAP.

The additional load on the cellular network depends on the DVB coverage and the population density. Our simulation results demonstrate a low level of DVB lost packets' retransmission load generated in the LTE network. The required RFR buffer sizes in smartphones are also small. We conclude that the RFR service is a viable solution for the QoS enhancement of TV transmission to the smartphones at a minor additional cost in terms of the network and device resources. At the same time we would like to emphasize on the necessity of confirming the presented results by field trials or some measurement campaigns.

Our proposal is based on CoAP which was originally designed for devices with very low processing power. Adding a CoAP driver in an LTE chipset thus induces a very small extra-complexity. However, an interesting extension of our study is to carry out a detailed complexity analysis.

REFERENCES

- [1] "Frequency and network planning aspects of DVB-T2," Eur. Broadcast Union, Geneva, Switzerland, Tech. Rep. 3348, 2011.
- [2] A. B. Alamanac *et al.*, "Performance validation of the DVB-SH standard for satellite/terrestrial hybrid mobile broadcasting networks," *IEEE Trans. Broadcast.*, vol. 57, no. 4, pp. 802–825, Dec. 2011.
- [3] A. Kumar, *Implementing Mobile TV*, 2nd ed., Elsevier Inc., Waltham, MA, USA, 2010.
- [4] *A cooperation Between 3GPP and the DVB Project on a Common Downlink Only Standard? Co-Operation Between 3GPP and the DVB Project*, Digital Video Broadcasting, Kansas, MO, USA, Mar. 2011.
- [5] G. Faria, J. A. Henriksson, E. Stare, and P. Talmola, "DVB-H: Digital broadcast services to handheld devices," *Proc. IEEE*, vol. 94, no. 1, pp. 194–209, Jan. 2006.
- [6] I. Elizmendi *et al.*, "Next generation of broadcast multimedia services to mobile receivers in urban environments," *Signal Process. Image Commun.*, vol. 27, no. 8, pp. 925–933, Sep. 2012.
- [7] I. Elizmendi *et al.*, "DVB-T2: The second generation of terrestrial digital video broadcasting system," *IEEE Trans. Broadcast.*, vol. 60, no. 2, pp. 258–271, Jun. 2014.
- [8] *Next Generation Broadcasting System to Handheld, Physical Layer Specification (DVB-NGH)*, document A160, Digital Video Broadcast., Nov. 2012.
- [9] D. Gomez-Barquero, C. Douillard, P. Moss, and V. Mignone, "DVB-NGH: The next generation of digital broadcast services to handheld devices," *IEEE Trans. Broadcast.*, vol. 60, no. 2, pp. 246–257, Jun. 2014.
- [10] Technical specification group services and system aspects; multimedia broadcast/multicast service (MBMS); architecture and functional description (release 9), 3GPP, Tech. Rep. TS 23.246, 2010.
- [11] G. Araniti, M. Condoluci, L. Militano, and A. Iera, "Adaptive resource allocation to multicast services in LTE systems," *IEEE Trans. Broadcast.*, vol. 59, no. 4, pp. 658–664, Dec. 2013.
- [12] Mobile Multi-Media (M^3) Project, L'Agence Nationale de la Recherche (ANR). *D21.2—Analysis on 3GPP E-MBMS/DVB-NGH Physical Layer Convergence*, 2012.
- [13] Z. Niu, L. Long, J. Song, and C. Pan, "A new paradigm for mobile multimedia broadcasting based on integrated communication and broadcast networks," *IEEE Commun. Mag.*, vol. 46, no. 7, pp. 126–132, Jul. 2008.
- [14] J. Santos *et al.*, "Multicast/broadcast network convergence in next generation mobile networks," *Comput. Netw.*, vol. 52, no. 1, pp. 228–247, Jan. 2008.
- [15] J. Qi, J. Zollner, J. Robert, L. Stadelmeier, and N. Loghin, "Redundancy on demand-extending the coverage area of terrestrial broadcast via broadband networks," *IEEE Trans. Broadcast.*, vol. 60, no. 2, Jun. 2014.
- [16] M. M. Anis, X. Lagrange, and R. Pyndiah, "Analyzing the coverage of the single frequency broadcast network for handheld receivers," in *Proc. IEEE 10th Consum. Commun. Netw. Conf. (CCNC)*, Las Vegas, NV, USA, 2013, pp. 689–692.
- [17] M. M. Anis, X. Lagrange, and R. Pyndiah, "Handheld receivers coverage by DVB-T2," in *Proc. IEEE 76th Veh. Technol. Conf. (VTC)*, Quebec, QC, Canada, 2012, pp. 1–5.
- [18] *FLUTE—File Delivery Over Unidirectional Transport*, Internet Eng. Task Force, Fremont, CA, USA, Nov. 2012.
- [19] T. Paila, "Unidirectional IP-based mass file delivery protocol," in *Proc. Ist Int. Symp. Wireless Commun. Syst.*, 2004, pp. 235–239.
- [20] D. Gomez-Barquero and A. Bira, "Error repair for broadcast transmissions in DVB-H systems," in *Wireless Communications and Mobile Computing*, vol. 9, Chichester, U.K.: Wiley, Jun. 2009, pp. 733–744.
- [21] B. Hechenleitner, "Repair costs of the IPDC/DVB-H file repair mechanism," in *Proc. Wireless Telecommun. Symp. (WTS)*, Pomona, CA, USA, 2008, pp. 137–144.
- [22] X. Liu, S. Raza, C.-N. Chuah, and G. Cheung, "Network coding based cooperative peer-to-peer repair in wireless ad-hoc networks," in *Proc. IEEE Int. Conf. Commun. (ICC)*, Beijing, China, 2008, pp. 2153–2158.
- [23] S. Raza, G. Cheung, and C.-N. Chuah, "DiCoR: Distributed cooperative repair of multimedia broadcast losses," in *Proc. 5th Int. Conf. Broadband Commun. Netw. Syst. (BROADNETS)*, London, U.K., 2008, pp. 315–322.
- [24] D. Gómez-Barquero, A. Fernández-Aguilella, N. Cardona, and A. Bria, "RRM for filecasting services in hybrid DVB-H/3G+ systems," in *Proc. IEEE Wireless Commun. Netw. Conf. (WCNC)*, Sydney, NSW, Australia, 2010, pp. 1–6.
- [25] F. Ren and C. Lin, "Modeling and improving tcp performance over cellular link with variable bandwidth," *IEEE Trans. Mobile Comput.*, vol. 10, no. 8, pp. 1057–1070, Aug. 2011.
- [26] C. Bormann, A. P. Castellani, and Z. Shelby, "CoAP: An application protocol for billions of tiny Internet nodes," *IEEE Internet Comput.*, vol. 16, no. 2, pp. 62–67, Mar./Apr. 2012.
- [27] O. Bergmann, K. T. Hillmann, and S. Gerdes, "A CoAP-gateway for smart homes," in *Proc. Int. Conf. Comput. Netw. Commun. (ICNC)*, Maui, HI, USA, pp. 446–450, 2012.
- [28] T. Potsch, K. Kuladinithi, M. Becker, P. Trenkamp, and C. Goerg, "Performance evaluation of CoAP using RPL and LPL in TinyOS," in *Proc. 5th Int. Conf. New Technol. Mobility Security (NTMS)*, Istanbul, Turkey, 2012, pp. 1–5.

- [29] D. Boswarthick, O. Elloumi, and O. Hersent, *M2M Communications: A Systems Approach*, 1st ed. Hoboken, NJ, USA: Wiley, 2012.
- [30] Z. Shelby, K. Hartke, C. Borman, and B. Frank, *Constrained Application Protocol (CoAP)*, Internet Eng. Task Force, Fremont, CA, USA, Dec. 2012.
- [31] D. Thangavel, X. Ma, A. Valera, H.-X. Tan, and C. K.-Y. Tan, "Performance evaluation of MQTT and CoAP via a common middleware," in *Proc. IEEE 9th Int. Conf. Intell. Sensors Sensor Netw. Inf. Process. (ISSNIP)*, Singapore, 2014, pp. 1–6.
- [32] *Frame Structure Channel Coding and Modulation for a Second Generation Digital Terrestrial Television Broadcasting System*, ETSI Standard EN 302 755, 2012.
- [33] N. Wells, *DVB-T2 in Relation to the DVB-x2 Family of Standards*, ATSC Inc., McLean, VA, USA, 2009.
- [34] *Implementation Guidelines for a Second Generation Digital Terrestrial Television Broadcasting System (DVB-T2)*, ETSI Standard TS 102 831, 2010.
- [35] T. Jokela, M. Tupala, and J. Paavola, "Analysis of physical layer signaling transmission in DVB-T2 systems," *IEEE Trans. Broadcast.*, vol. 56, no. 3, pp. 410–417, Sep. 2010.
- [36] S. Lembo, K. Ruttik, and O. Tirkkonen, "Modelling BLER performance of puncture turbo codes," in *Proc. IEEE WPMC Symp.*, 2009.
- [37] M. M. Anis, H.-L. Maattanen, and O. Tirkkonen, "Performance prediction of a turbo-coded link in fading channels," M.S. thesis, Dept. Commun. Netw., Aalto Univ. School Sci. Technol., Espoo, Finland, 2010.
- [38] C. Desset, B. Macq, and L. Vandendorpe, "Computing the word-, symbol-, and bit-error rates for block error-correcting codes," *IEEE Trans. Commun.*, vol. 52, no. 6, pp. 910–921, Jun. 2004.
- [39] M. M. Anis, X. Lagrange, and R. Pyndiah, "A simple model for the DVB and LTE cooperation," in *Proc. IEEE 8th Broadband Multimedia Syst. Broadcast. (BMSB) Symp.*, London, U.K., 2013, pp. 1–6.
- [40] A. A. Razzac, S. E. Elayoubi, T. Chahed, and B. El-Hassan, "Impact of LTE and DVB-NGH cooperation on QoS of mobile TV users," in *Proc. Int. Conf. Commun. (ICC)*, Budapest, Hungary, 2013, pp. 3672–3677.
- [41] P. Mogensen *et al.*, "LTE capacity compared to the Shannon bound," in *Proc. IEEE 65th Veh. Technol. Conf. (VTC)*, Dublin, Ireland, 2007, pp. 1234–1238.
- [42] J. Skold, E. Dahlman, and S. Parkvall, *4G: LTE/LTE-Advanced for Mobile Broadband*, 1st ed., Elsevier Inc., Waltham, MA, USA, 2011.
- [43] *Definitions of Managed Objects for Remote Ping, Traceroute, and Lookup Operations*, IETF Standard RFC 4560, 2006.