



HAL
open science

Thermoelectric Harvester to power SHM Sensors in Aircraft Pylon

Paul Durand-Estèbe, Vincent Boitier, Marise Baffleur, Jean-Marie Dilhac

► **To cite this version:**

Paul Durand-Estèbe, Vincent Boitier, Marise Baffleur, Jean-Marie Dilhac. Thermoelectric Harvester to power SHM Sensors in Aircraft Pylon. 5èmes Journées Nationales sur la Récupération et le Stockage d'Énergie pour l'Alimentation des Microsystèmes Autonomes (JNRSE'2015), IEF, Université Paris Sud - CNRS, May 2015, Orsay, France. hal-01239488

HAL Id: hal-01239488

<https://hal.science/hal-01239488>

Submitted on 8 Dec 2015

HAL is a multi-disciplinary open access archive for the deposit and dissemination of scientific research documents, whether they are published or not. The documents may come from teaching and research institutions in France or abroad, or from public or private research centers.

L'archive ouverte pluridisciplinaire **HAL**, est destinée au dépôt et à la diffusion de documents scientifiques de niveau recherche, publiés ou non, émanant des établissements d'enseignement et de recherche français ou étrangers, des laboratoires publics ou privés.

Thermoelectric harvester to power SHM sensors in aircraft pylon

P. Durand Estebe, V. Boitier, M. Bafleur, J-M. Dilhac

CNRS, LAAS
Toulouse, France
pdurande@laas.fr

Abstract— In this paper, we present the conception and realization of a thermoelectric harvester that will be installed in a harsh environment A380 pylon to power a SHM datalogger.

Keywords— Thermoelectric, SHM, extreme temperature.

I. INTRODUCTION

Wireless Sensor Networks (WSN) have been considered for various aeronautical applications, such as Structural Health Monitoring (SHM) [1]. However, sensors nodes need to be self-powered, many of the advantages of wireless sensor networking being obviously lost if wired power sources were used. Despite their advantages, batteries present critical drawbacks, particularly for aeronautic applications.

Combination of energy transducers and supercapacitors (SCs) is a good alternative to energy supply.

We present here hands-on experience related to on-going implementation of energy harvesters in airliners for the purpose of SHM powering during a flight test. The system will be implemented in an A380 pylon, the part that holds the engine to the wing of the plane. Devised harvesting system is a thermoelectric harvester since heat from engine creates a thermal gradient with ambient air in the pylon which is ventilated to prevent fuel vapor to dangerously accumulate, then keeping ambient air cooler than pylon surface.

The design of this energy harvester has to fulfil several criteria:

- Robustness: it has to handle high working temperature (hot side can reach temperature up to 300°C), strong vibrations, lightning protection (ElectroMagnetic Impulsions (EMI)), etc.
- Safety: the harvester must not present any risk for the aircraft, even in extreme case, in particular during engine fire where temperature may rise up to 1100°C
- And of course, it has to harvest and supply enough energy to power the load.

The thermogenerator (TEG) and its related electronics are not placed at the same location: electronics is deported in a cooler zone next to SHM dataloggers.

II. TEG ASSEMBLY

Few TEGs are able to handle 300°C. We chose a 5x5cm

thermogenerator from Kelk (no smaller TEG exists with this high temperature technology) designed to have a maximum efficiency with a 220°C gradient to provide 24W.

As a TEG is quite fragile for an aircraft application (encapsulation is made of thin ceramic plate) and also for ease of implementation, we use a stainless steel support that is directly in contact with the hot surface of the pylon. To design it, we measured the TEG thermal resistivity and simulated the final assembly (see **Figure 1**) to estimate the thermal gradient at TEG sides and the related output power. Gradient value highly depends on the convection factor h of the heat sink that will be placed on top of the TEG, simulations have been carried out for h going from $h=5$ to $h=100$ W/(m²*K).

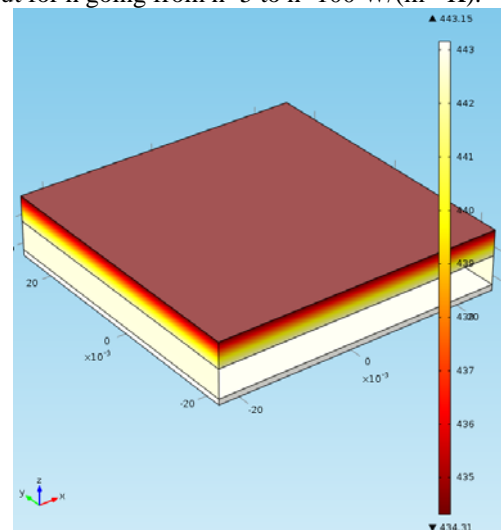

Figure 1. TEG simulation on its metallic support for a 50°C air temperature, 170°C support, $h=10$ W/(m²*K) showing 8°C gradient.

The TEG assembly (see **Figure 2**) is designed as following: a pure copper heat sink is placed on the cold side and is maintained by small titanium rods. The rods are strongly fixed on the support with steel screws through small high temperature polymer (Duratron®) in order to thermally isolate the cold heat sink and rods from the hot stainless steel support. High temperature connectors are used to connect the TEG output to the electronic board that is deported in a cooler area.

We tested this device in a temperature regulated oven to validate and measure electrical characteristics of the TEG in

conditions as close as possible to the conditions in the aircraft, from hot side temperature going from 170°C to 285°C (ambient air from 60°C to 90°C).

For a typical temperature case, (ambient air at 70°C, support at 180°C), TEG maximum output power is 39mW at 0.37V. Open voltage is 0.77 V and short-circuit current is 220mA.

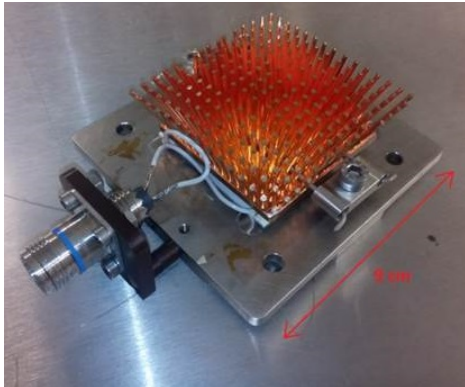

Figure 2. Thermogenerator final assembly. TEG device is under the copper heat sink.

III. HMEC BOARD

From TEG characteristics, we designed the management circuit called HMEC (Health Monitoring Energy Converter) (Figure 3).

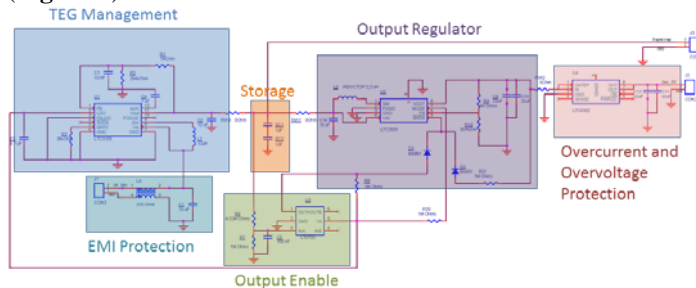

Figure 3. HMEC schematic with main blocks highlighted. The harvester electronic circuit is designed with a classic architecture with commercial components to maximize the reliability of the system, as we will not be able to modify anything once it is mounted on the aircraft. It is composed of:

- An input common mode filter to serve as an EMI protection against lightning risks.
- A Linear Technology LTC3105 component to achieve:
 - o Impedance matching with the TEG,
 - o Storage voltage regulation
 - o It provides a low power LDO to power the output enabling comparator.
- Two Maxwell BCAP0003 3.3F, 2.3V supercapacitors to be used as storage. As they are connected in series, the equivalent storage value is 1.65F with 4.6V maximum voltage.
- A low power LT6700 comparator to activate the output stage only when storage voltage is high enough.
- A high efficiency LTC3539 boost regulator to

perform output regulation.

- A LTC4362 short-circuit protection to protect HMEC against load short-circuit or too high current drawing from the load. Its purpose is to increase HMEC reliability.

The circuit is placed in an aluminium box and will be screwed on a metal plate inside the aircraft. TEG and HMEC will be connected with shielded cable to provide maximum protection from EMI induced by lightning events.

The electronic circuit has been tested in a heated/cooled stove at temperature from -60°C to 125°C. It successfully worked from -50°C to 125°C. At temperatures lower than -50°C, supercapacitors electrolyte freezes and thus, supercapacitors no longer show any capacitive behavior. This extreme temperature should not be reached but if it was, the malfunction of the supercapacitors will be temporary and as soon as the temperature goes back to values higher than -50°C, they will recover their functionality.

We tested the complete system with the TEG in a heated oven with ambient air temperature at 70°C and support temperature at 160°C connected to the HMEC. The HMEC was then connected to an active load that simulated the datalogger consumption profile.

In Figure 4, we can see the harvested power (calculated as the energy being stored in storage supercapacitors) versus the voltage at storage terminal. As expected, we can notice that until the storage reaches 1.2V, energy harvested is low. This phenomenon is due to the LTC3105: as it is a boost regulator, its output has to be high enough (1.2V) to reach a good efficiency.

The harvested power fall that occurs at 2.3V is due to output activation: it shows the power consumption of the LTC3539 and LT4362.

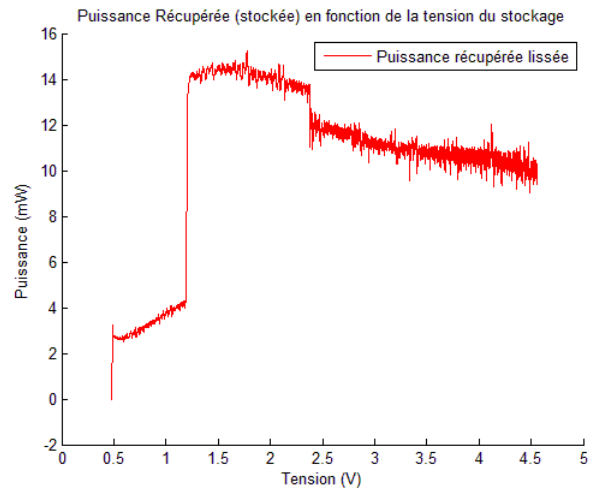

Figure 4. Power harvested by the HMEC vs storage voltage.

IV. CONCLUSION

Presented harvester has been designed to overcome extreme environmental conditions, particularly concerning thermal and mechanical engineering with the thermoelectric transducer. It will be installed on a test aircraft to perform experiments in real situation towards the end of 2015.