



**HAL**  
open science

# Comparison of Analysis Line and Polytopes Methods to Determine the Result of a Tolerance Chain

Laurent Pierre, Bernard Anselmetti

► **To cite this version:**

Laurent Pierre, Bernard Anselmetti. Comparison of Analysis Line and Polytopes Methods to Determine the Result of a Tolerance Chain. CIRP CAP 2014, May 2014, Hangzhou, China. 10.1115/1.4029049 . hal-01239288

**HAL Id: hal-01239288**

**<https://hal.science/hal-01239288>**

Submitted on 16 Dec 2015

**HAL** is a multi-disciplinary open access archive for the deposit and dissemination of scientific research documents, whether they are published or not. The documents may come from teaching and research institutions in France or abroad, or from public or private research centers.

L'archive ouverte pluridisciplinaire **HAL**, est destinée au dépôt et à la diffusion de documents scientifiques de niveau recherche, publiés ou non, émanant des établissements d'enseignement et de recherche français ou étrangers, des laboratoires publics ou privés.

## Comparison of analysis line and polytopes methods to determine the result of a tolerance chain

Laurent PIERRE<sup>a,b</sup>, Bernard ANSELMETTI<sup>a,b</sup>

<sup>a</sup>LURPA, ENS Cachan, 61, Avenue du président Wilson, 94 235 Cachan, France

<sup>b</sup>Université Paris-Sud, IUT de Cachan, 9, Avenue de la division Leclerc, 94 230 Cachan, France

---

### Abstract

Functional tolerancing must ensure the assembly and the functioning of a mechanism. There are several types of functional requirements: mainly the assembly requirements which are expressed in terms of maximum material conditions and accuracy requirements that impose minimum material conditions.

The approach consists of five steps:

- Definition of each functional requirement by geometrical characteristics between some functional surfaces of mechanism and determination of the limit values of this characteristic allowing insuring the requirement with an acceptable risk,
- Determination of the annotations of each part with the standards ISO of dimensioning and tolerancing,
- Choice of the tolerances of each specification of each part,
- Verification that the accumulation of the tolerances guarantees the respect for all the requirements,
- Optimization of the allocation of tolerances to minimize cost or to maximize the capability of manufacturing processes.

In this approach of functional dimensioning, the tolerance analysis is a very delicate stage to take into account the dimensional and angular effects. The problem is to ensure that the studied functional requirement will be well respected considering the tolerances on influential parts.

The aim of this paper is to compare two methods of tolerance analysis of a mechanical system: the method of "analysis lines" and the method of "polytopes".

The first method needs a discretization of the ending functional surface according to various analysis lines placed on the outer-bound of the face and oriented along the normal of the surface. For each analysis line, the result is the sum of the influences of each junction defects on the search characteristic using pre-established relations for classical types of junctions. The calculation is very fast and it can express the result as a formula according to the tolerances, if necessary with a statistical approach.

The second method uses polytopes (finite sets of point in  $\mathbb{R}^n$ ). The polytopes are defined from the acceptable limits of the geometric deviations of parts and possible displacements between two parts. Minkowski sums and intersections polytopes are then carried out to take into account all geometric variations of a mechanism. Tools like OpenCASCADE have been developed to quickly realize intersections and Minkowski sums.

This comparison is performed on a simple example specified with the method CLIC. The requirement is the assembly condition of a shaft in two bores of two different parts which involves straightness in common zone of the bores.

Comparison of these results shows that solutions are identical. Assumptions and model behavior bonds are also identical.

*Keywords:* Functional tolerancing; tolerance analysis; Analysis line; Polytop; ISO tolerancing standard;

---

### 1. Functional tolerancing context

Now the evolution of digital tools allows designers to define their entire mechanism in a CAD environment. The parts are described as perfect shape with nominal dimensions. To ensure interchangeability and allow the production

of parts at lower cost, it is very important to allocate the widest possible tolerances, while ensuring that the functional requirements of the mechanism are respected. With this approach, the designer chooses the geometric specifications and tolerances. He must ensure that the combination of the variations permitted by the tolerances will be compatible with each requirement. This step is called *tolerance analysis*.

Traditionally, tolerance analysis is provided by a tolerance chart model in only one direction which is simply to sum of tolerances of influential parts. Soon as there is an angular effect in the chain of dimensions, designers are still quite poor. Indeed, there are very few commercial software tools for the analysis of tolerances in 3D. The principle is based on the simulation of assemblies:

- Mécamaster [1] simulates the assembly of nominal parts but introduces deviations between parts corresponding to tolerances of the support surfaces or clearance in joint.

- Cetol [2], 3DCS [3] generate, by Monte Carlo methods, parts with position, orientation or form defects corresponding to the ISO specifications. Such software measures the characteristic of the requirement on the set of assemblies obtained with simulated parts.

- Anatole [4] characterizes defects of surfaces with small displacement torsor. The equations expressing the displacement of the parts relative to their nominal positions are based on contact between parts to give a formal relationship of part tolerances.

Since 1997, B. Anselmetti developed the CLIC method (a French acronym for "Localization Tolerancing with Contact Influence") [5]. This system proposes the automatic generation of functional requirements and functional specifications in accordance with ISO tolerancing standards. The result of each tolerance chart is described by an EXCEL formula according to tolerances of influential parts. This structure allows optimizing the nominal dimensions of CAD model to maximize tolerances [6].

In this software, tolerance analysis is ensured by the analysis line method. The ending functional surface is discretized by various analysis lines placed on the outer-bound of the face and oriented along the normal to the surface. The principle consists in the sum of the influence of defects in each junction on analysis line using relationship pre-established for all classical types of junctions. The calculation is very fast and expresses the result with a formula function of tolerances with worst case or with a statistical approach.

The method of operations on polytopes in tolerance analysis is a variational approach based on the work initiated by Flemming in 1988. It is based on the operations of sets of geometric constraints [7]. The set of possible positions of a surface within a tolerance zone is characterized by a set of geometric constraints. This allows characterizing the geometric variations of a part according to orientation or position ISO specifications [8], [9], [10], [11]. Similarly, a set of geometric constraints characterises all relative positions between two distinct surfaces potentially in contact [12]. Fleming established the correlation between the accumulated defects limits on parts and the Minkowski sum of finite sets of geometric constraints [7]. A summary of these issues is detailed in [13]. Giordano showed that the relative position between two parts in contact resulting from a number of potential contacts can be formalized by an intersection operation of a set of geometric constraints [14]. More generally, the variational tolerancing approach is to characterise the relative position between two surfaces of two parts of any system by intersections and Minkowski sums of sets of geometric constraints. This sets of constraints result from ISO specifications expressed in parts and contact characteristics between two parts [15]. Minkowski sum algorithms applied to the problem of tolerance analysis have been developed [16], [17]. A variational method of tolerance analysis using the method based on operations on polytopes is proposed by [18] and [19]. This method was developed to take into account thermomechanical strains.

The aim of this paper is to compare these two methods on an example to show the similarities and limitations.

## 2. Definition of requirement

### 2.1. Mechanism description

The mechanism is composed of two rigid parts with two bores (Fig. 1). The shaft is represented by a single cylinder which is mounted with clearance in a bore of the cover and in a bore of the housing. The cover is assembled and screwed onto the housing, before introducing the shaft. It must therefore be ensured that the shaft can be fitted in the mechanism in any case.

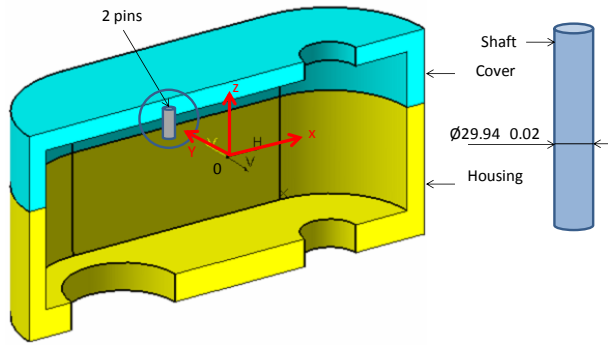

Fig. 1. Mechanism

2.2. Functional tolerancing

Functional tolerancing was performed with the Quick GPS software developed by B. Anselmetti [20] in the CATIA environment with Functional Tolerancing Annotation Workshop.

The junction is described by a positioning table of the cover on the housing (Fig. 2).

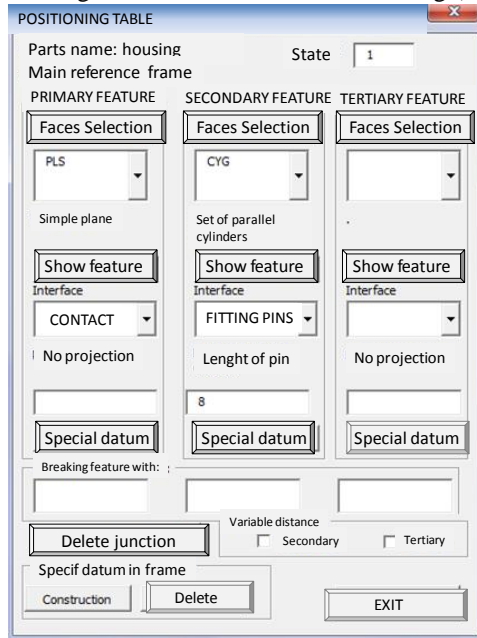

Fig. 2. Setting-up table of the cover on the housing

The housing is the base of this mechanism. The cover is setting-up on the housing by a primary plane and two bores which receive two pins blocked in the housing. There is clearance between the pins and the cover.

A simple matrix shows all the links in the part studied (Fig. 3). The hole of the cover has to be positioned relative to the junction with the housing.

		hole cover.1;CYS : 15
References	R1 ; AB	
		P
R1 ; AB		

Fig. 3. Link inside cover

These data are sufficient for the QUICK GPS software that automatically generates annotations in the 3D CAD model (Fig. 4). The designer can adjust the tolerances.

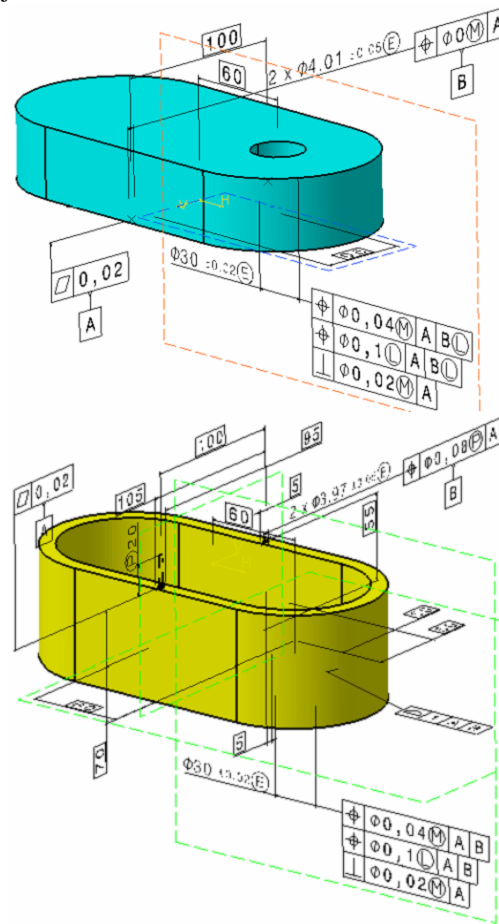

Fig. 4. ISO tolerancing of the two parts

Each part has a main datum reference frame AB and a location of the bore.

### 2.3. Functional requirement

This paper examines more specifically the assembling of the shaft in the sub system composed by housing and cover. The assembling is difficult when the shaft and the bores are at maximum material condition, when the cover and housing are shifted due to the clearance between the pins and the cover (Fig. 5).

The shift is maximum when the distances between the pins are the same on both parts and the pins and the holes in the cover are at minimum material condition with a maximum clearance of 0.04.

The problem is really three-dimensional, because the holes are not in the plane containing the two pins. But to simplify the Fig. 5, the pins are shown in the plane of bores.

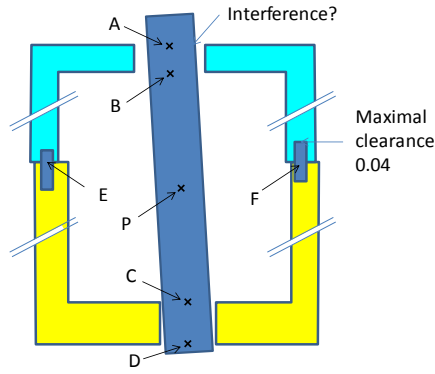

Fig. 5. Assembling requirement of the shaft

### 2.4. Methodology

At maximum material condition, the shaft is considered a perfect cylinder of diameter 29.96. The envelop diameters of the bores are 29.98 mm. If the straightness in common zone of the two holes is  $r$ , then the free space for the shaft is  $29.98 - r$ . The straightness has to be less than 0.02 in all cases.

### 2.5. Tolerancing and significant dimensions

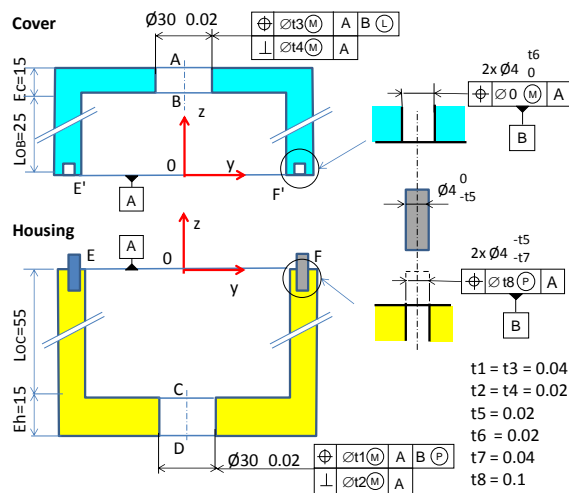

Fig. 6. Main specifications

## 3. Analysis line method

### 3.1. Principle

The analysis lines method was developed in 2004, to calculate the resulting 3D with a statistical approach. The challenge is to globalize the influence dues to translation and angular deviations, whatever the tolerance values. Calculation equations show that the accumulation occurs naturally in certain points and in particular directions called *analysis points* and *analysis directions*.

The analysis line method is based on transfer relations that have been established for ten classical junctions (Primary plane / secondary plane / tertiary plane, Primary plane / secondary cylinder / tertiary, Primary plane / 2 secondary holes, Primary plane / n secondary holes; Primary cylinder / secondary plane / tertiary, straightness or flatness in common zone ...).

The linear relationship gives the influence of a given junction in the worst case, directly on the functional requirement. This requires a discretization and successive studies in a limited number of directions. The advantage of this method is that for each study, the analysis direction is known. It is very easy to define the position of the part in the worst case permitted by clearance in the junction.

Other junctions can often be modeled by 6 points of contact with a linear relationship. Some complex connections cannot be treated directly. The solution proposed by Robin Chavanne [21] is to use a solver to find the worst case situation and to find the 6 contact points to establish the linear relationship.

### 3.2. Transfer of straightness

The requirement studied thus reduces to straightness between two coaxial bores. The deviation from straightness  $r$  is the diameter of a cylinder containing both real axis of the two bores.

The problem is three-dimensional. The analysis line method proposes to study in 8 radial directions  $f_1$  to  $f_8$ .

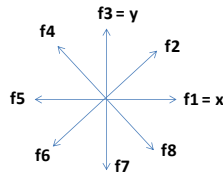

Fig. 7. Discretization in 8 analysis directions

Fig. 8 can be applied to all cases of straightness in common zone of two coaxial cylinders (Fig. 8a).

A location and an orientation specifications are placed on each bore with respect to a common datum reference frame fixed on the housing (Fig. 8b).

Fig. 8c shows that in each planes in  $f_i$  direction, straightness is proportional to the sum of the maximum displacement  $d(C_H, f_i)$  of point  $C_H$  of the housing axis in  $f_i$  direction and the maximal displacement  $d(C_C, -f_i)$  of point  $C_C$  of the cover axis projected in point C in  $-f_i$  direction. Lengths of bores are respectively  $E_C$  and  $E_H$ . The distance between the bores is  $L_{BC}$ . The symmetrical condition is presented in Fig. 8d.

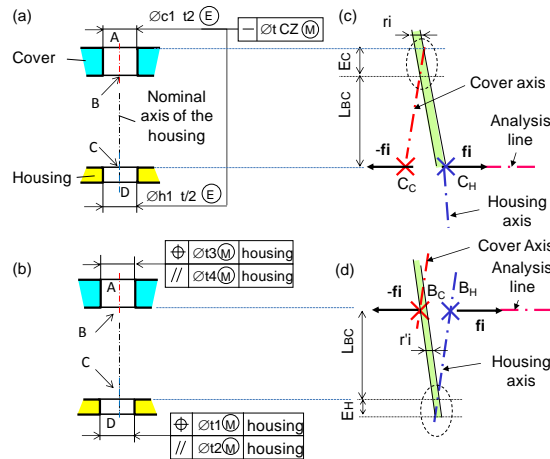

Fig. 8. Straightness between two different parts

The relationship of transfer is therefore:

$$r_i = \max \left\{ \begin{array}{l} \frac{E_C}{E_C + L_{BC}} [d(C_H, f_i) + d(C_C, -f_i)]; \\ \frac{E_H}{E_H + L_{BC}} [d(B_H, f_i) + d(B_C, -f_i)] \end{array} \right\} \quad (1)$$

These displacements  $d(B_H, \mathbf{fi})$ ,  $d(C_H, \mathbf{fi})$ ,  $d(B_C, -\mathbf{fi})$ ;  $d(C_C, -\mathbf{fi})$  should be calculated relative to the same reference. The reference is chosen on the median line of both axis B of the datum reference frame AB of the housing.

Firstly, the maximal displacement of the points  $B_C$  and  $C_C$  of the cover axis are calculated with respect to the nominal cover axis according to the specifications of the bore.

The nominal cover axis is also the median line of both reference axis B of the cover

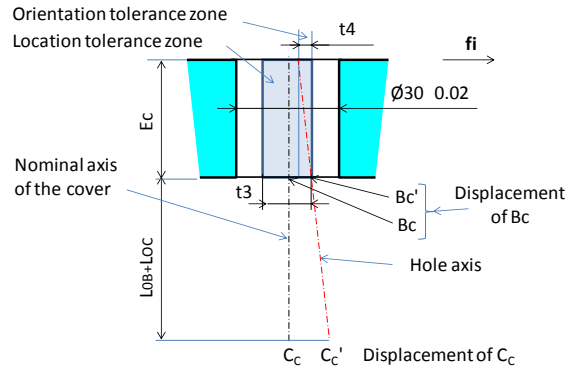

Fig. 9. Influence of the cover

In the worst case, point  $B_C$  moves in  $B_C'$ . The displacement of point  $B_C$  is limited by the location tolerance  $t_3$ :

$$d(B_C, \mathbf{fi}) = t_3/2 \quad (2)$$

Point  $C_C$  moves in  $C_C'$ . The inclination of the axis of the bore is limited by the specification of orientation  $t_4$ . The displacement of point  $C_C$  is:

$$d(C_C, \mathbf{fi}) = t_3/2 + t_4 \cdot (L_{OB} + L_{OC})/E_C \quad (3)$$

The calculation is similar to the points  $B_H$  and  $C_H$  of the housing axis with the tolerance  $t_1$  in location and  $t_2$  in orientation.

$$\begin{aligned} d(C_H, \mathbf{fi}) &= t_1/2 \\ d(B_H, \mathbf{fi}) &= t_1/2 + t_2 \cdot L_{BC}/E_H \end{aligned} \quad (4)$$

By symmetry, these relationships are independent of analysis directions  $\mathbf{fi}$ .

Displacements of points  $B$  and  $C$  of the nominal cover axis must now be determined according to the housing.

### 3.3. Influence of clearance in junction housing/cover

The problem is to calculate the displacements of the nominal axis of cover in  $B_C$  and in  $C_C$

The cover is setting-up on the housing with a primary plane and two pins. The datum reference frame of the housing is AB. Datum plane A of the housing and datum plane A of the cover are supposedly confused.

The nominal axis of the holes being perpendicular to the primary plane, there is no angular deviations between both nominal axis of the housing and cover.

The shift of the nominal axis is due only to the mobility permitted by the clearance  $J$  between the housing and the cover. Fig. 10 shows both axis E and F of the housing holes, and both axis E' and F' of the cover holes in the cover.

The connection between these bores is provided by the pins blocked in the housing. Displacement is maximum when the distance between the holes are identical in housing and the cover and when the pins and the cover holes are at least material condition with a maximum clearance  $J$ .

If the analysis line  $d(B_C, \mathbf{fi})$  cut segment  $EF$ , the maximum displacement in the direction  $\mathbf{fi}$  is equal to  $J/2$ .



If the analysis line  $d(B_C, \mathbf{fi})$  does not cut the segment  $EF$ , the displacement of  $B_C$  is maximal when E move in  $E'$  and when F move in  $F'$  in  $\varphi$  direction.

The displacement of the point  $B_C$  depends of the angle  $\varphi$ . The derivation shows that the displacement is maximum, irrespective of the angle  $\theta$  value, when the points  $B_C$ ,  $E$  and  $E'$  are aligned, either for  $\varphi = \arctan(OB_C/OE)$ .

In this case, the displacement of  $B_C$  is  $J/\cos\varphi \cdot \mathbf{y}$ . The maximal displacement in  $\mathbf{fi}$  direction is:

$$d(B_C, \mathbf{fi}) = J \cdot \cos\theta / \cos\varphi \quad (5)$$

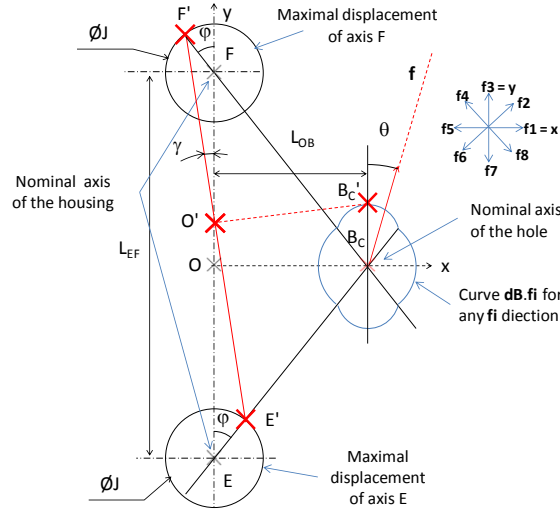

Fig. 10. Influence of junction housing/cover

The maximal clearance between pins and hole of cover is:

$$J = D_{\max\_hole} - D_{\min\_pin} = t_5 + t_6 \quad (6)$$

Both distances  $L_{EF} = 100$  mm and  $L_{OB} = 60$  mm,  $1/\cos\varphi = 1.56$ . Calculated displacements are:

For  $\mathbf{f1} = \mathbf{x}$  and  $\mathbf{f5} = -\mathbf{x}$ :

$$d(B_C, \mathbf{fi}) = J/2 \quad (7)$$

For  $\mathbf{f3}$  and  $\mathbf{f7}$ ,  $\cos\theta = \pm 1$ :

$$d(B_C, \mathbf{fi}) = J / (2 \cdot \cos\varphi) = 1.56 \cdot J/2 \quad (8)$$

For  $\mathbf{f2}$ ,  $\mathbf{f4}$ ,  $\mathbf{f6}$  et  $\mathbf{f8}$ ,  $\theta = \pi/4$ :

$$d(B_C, \mathbf{fi}) = J / (2 \cdot \sqrt{2} \cdot \cos\varphi) = 1.104 \cdot J/2 \quad (9)$$

### 3.4. Full condition

The full condition giving the straightness in the worst case is the maximum value of 8 relationships in 8 directions  $\mathbf{fi}$ .

$$r_i = \max \left\{ \begin{array}{l} \frac{E_C}{E_C + L_{BC}} [d(C_H, \mathbf{f}_i) + d(C_C, -\mathbf{f}_i)]; \\ \frac{E_H}{E_H + L_{BC}} [d(B_H, \mathbf{f}_i) + d(B_C, -\mathbf{f}_i)] \end{array} \right\} \quad (10)$$

With

$$\begin{aligned} d(C_H, -\mathbf{f}_i) &= t_1/2 \\ d(B_H, -\mathbf{f}_i) &= t_1/2 + t_2 \cdot L_{BC}/E_H \end{aligned} \quad (11)$$

Maximal displacements of  $B_C$  and  $C_C$  depend on  $\mathbf{f}_i$  direction. The displacement is maximal for  $\mathbf{f}_3$  and  $\mathbf{f}_7$  directions in plane  $(\mathbf{y}, \mathbf{z})$ :

$$\begin{aligned} d(C_C, \mathbf{f}_i) &= t_3/2 + t_4 \cdot L_{BC}/E_C + (t_5 + t_6)/(2 \cdot \cos \varphi) \\ d(B_C, \mathbf{f}_i) &= t_3/2 + (t_5 + t_6)/(2 \cdot \cos \varphi) \end{aligned} \quad (12)$$

The straightness is obtained in plane  $(\mathbf{y}, \mathbf{z})$ :

$$r_i = \max \left\{ \begin{array}{l} \frac{E_C}{E_C + L_{BC}} \left[ \frac{t_1}{2} + \frac{t_3}{2} + t_4 \cdot \frac{L_{BC}}{E_C} + \frac{t_5 + t_6}{2 \cdot \cos \varphi} \right] \\ \frac{E_H}{E_H + L_{BC}} \left[ \frac{t_1}{2} + \frac{t_3}{2} + t_2 \cdot \frac{L_{BC}}{E_H} + \frac{t_5 + t_6}{2 \cdot \cos \varphi} \right] \end{array} \right\} \quad (13)$$

with:  $\varphi = \arctan(OB_C/OE)$

These relationships are linear and simple to integrate into a system of equations for the synthesis of tolerances.

#### 4. Method by operations on polytopes

##### 4.1. Transfer of geometric deviations on parts

A real surface resulting from the manufacturing is modelled by a surface of substitution that has the same type as the nominal surface. The deviations between the surface of substitution and nominal surface are called geometric deviations. The surface of substitution  $i$  of the part  $j$  is noted  $i, j$ . Geometric deviations between a surface of substitution 1,1 and a surface of substitution 1,2 are formalized by a small displacement torsor  $[d_{1,1/1,2}]$ , where the vector  $\mathbf{p}_{1,1/1,2}$  is the rotation vector of 1,1 with respect to 1,2 while the vector  $\mathbf{\epsilon}_{B-1,1/1,2}$  is the translational vector of 1,1 with respect to 1,2 at point B:

$$[d_{1,1/1,2}] = \begin{bmatrix} \mathbf{p}_{1,1/1,2} \\ \mathbf{\epsilon}_{B-1,1/1,2} \end{bmatrix}_B \quad (14)$$

According to the specification of the location of axis 1,1 of the bore of the housing 1 (Fig. 6), the axis of the cylindrical surface of substitution 1,1 is within a tolerance zone  $ZT$ .  $ZT$  is a cylinder of diameter  $\varnothing t_1$  orthogonal to the plane A and centered on nominal axis relating to AB datum reference frame. To ensure that the axis 1,1 of the surface is located in the zone of tolerance, it is necessary to write, to both points C and D, the following relationship where  $\mathbf{n}_{\theta_i}$  is a unitary vector orthogonal to the axis  $\mathbf{z}$  and  $\theta_i$  is the discretization angle around the axis  $\mathbf{z}$ :

$$\begin{cases} -\frac{t_1}{2} \leq \boldsymbol{\varepsilon}_{C-1,1/AB} \cdot \mathbf{n}_{\theta_i} \leq \frac{t_1}{2} \\ -\frac{t_1}{2} \leq \boldsymbol{\varepsilon}_{D-1,1/AB} \cdot \mathbf{n}_{\theta_i} \leq \frac{t_1}{2} \end{cases} \quad (15)$$

with  $\begin{cases} \mathbf{n}_{\theta_i} = \cos \theta_i \cdot \mathbf{x} + \sin \theta_i \cdot \mathbf{y} \\ \theta_i = i \frac{\pi}{n}, 0 \leq i < n \text{ and } (i, n) \in \square \end{cases}$

The relation (15) is expressed according to the rotation vector and the translation vector of the deviation of the point P middle of the bounded by line segment B and C (Fig. 5):

$$\begin{cases} -\frac{t_1}{2} \leq (\boldsymbol{\varepsilon}_{P-1,1/AB} + \mathbf{CP} \wedge \boldsymbol{\rho}_{1,1/AB}) \cdot \mathbf{n}_{\theta_i} \leq \frac{t_1}{2} \\ -\frac{t_1}{2} \leq (\boldsymbol{\varepsilon}_{P-1,1/AB} + \mathbf{CD} \wedge \boldsymbol{\rho}_{1,1/AB}) \cdot \mathbf{n}_{\theta_i} \leq \frac{t_1}{2} \end{cases} \quad (16)$$

with  $\begin{cases} \mathbf{n}_{\theta_i} = \cos \theta_i \cdot \mathbf{x} + \sin \theta_i \cdot \mathbf{y} \\ \theta_i = i \frac{\pi}{n}, 0 \leq i < n \text{ and } (i, n) \in \square \end{cases}$

The relations (16) define a bounded intersection of finite number of closed half-spaces whose boundaries are hyperplanes of  $\square^4$  [15] intersection. In general, it can formalize the h-representation of a polytope called geometric polytope, noted  $D_{1,1/AB}^g$ .  $D_{1,1/AB}^g$  represents the geometric polytope of the location of the surface 1,1 with respect to AB. This is 4-polytope in which two graphical representations are shown in Fig. 11. The Fig. 11a and the Fig. 11b represent two projections of 4-polytope respectively in  $(\rho_x, \varepsilon_{P,y})$  and in  $(\rho_y, \varepsilon_{P,x})$ .

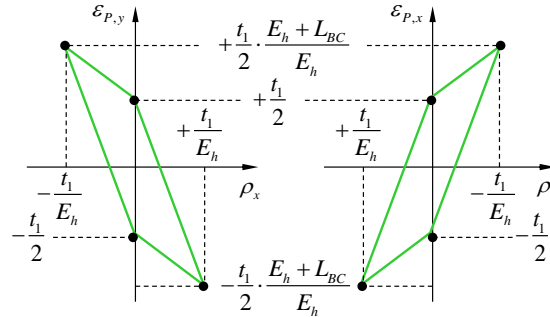

Fig. 11. Geometric polytope  $D_{1,1/AB}^g$

The orthogonality of the housing axis 1,1 with respect to the datum A can be characterized by a geometric polytope  $D_{1,1/A}^g$ . The axis of the cylindrical surface of substitution 1,1 is within a tolerance zone  $TZ$ .  $TZ$  is a cylinder of diameter  $\varnothing t_2$  orthogonal to the plane A. To ensure that the axis of the surface 1,1, is within the orientation tolerance zone  $TZ$ , the orthogonal distance to the axis  $\mathbf{y}$  between the points C and D must be less than the dimension of the tolerance zone:

$$-t_2 \leq (\boldsymbol{\varepsilon}_{C-1,1/A} - \boldsymbol{\varepsilon}_{D-1,1/A}) \cdot \mathbf{n}_{\theta_i} \leq t_2$$

with  $\begin{cases} \mathbf{n}_{\theta_i} = \cos \theta_i \cdot \mathbf{x} + \sin \theta_i \cdot \mathbf{y} \\ \theta_i = i \frac{\pi}{n}, 0 \leq i < n \text{ and } (i, n) \in \square \end{cases} \quad (17)$

The relation (17) is expressed according to the rotation vector and the translation vector of the deviation of the point P middle of the bounded by line segment B and C:

$$-t_2 \leq (\mathbf{\varepsilon}_{C-1,1/A} - \mathbf{\varepsilon}_{D-1,1/A}) \cdot \mathbf{n}_{\theta_i} \leq t_2$$

$$\text{with } \begin{cases} \mathbf{n}_{\theta_i} = \cos \theta_i \cdot \mathbf{x} + \sin \theta_i \cdot \mathbf{y} \\ \theta_i = i \frac{\pi}{n}, 0 \leq i < n \text{ and } (i, n) \in \square \end{cases} \quad (18)$$

Relations (18) formalize the geometric polytope, noted  $D_{1,1/A}^g$ , corresponding to the location of 1,1 with respect to the reference A. This is a 2-polytope whose graphical representation is given in Fig. 12 in  $(\rho_x, \rho_y)$ .

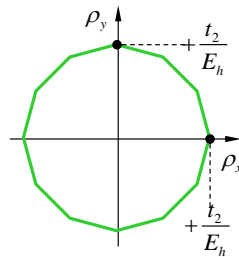

Fig. 12. Geometric polytope  $D_{1,1/A}^g$

Both specifications expressed on the axis 1,1 of the housing 1 must be respected simultaneously. The polytope characterizing the position of the axis 1,1 with respect to the datum reference frame AB is the polytope resulting from the intersection between the polytopes  $D_{1,1/AB}^g$  and  $D_{1,1/A}^g$ . This is a 4-polytope in which two graphical representations are shown in Fig. 13. Fig. 13a and Fig. 13b represent the projections of the 4-polytope in  $(\rho_x, \varepsilon_{P,y})$  and  $(\rho_y, \varepsilon_{P,x})$ .

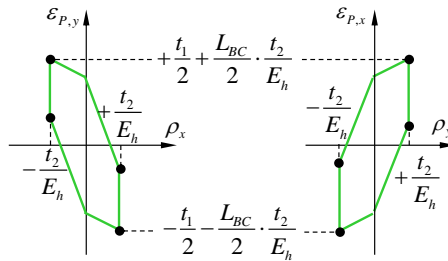
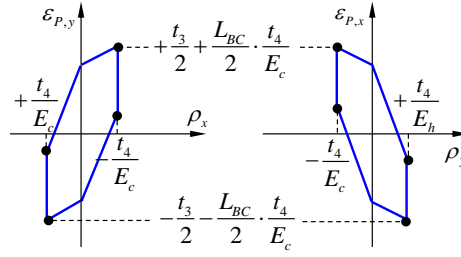

Fig. 13. Global geometric polytope  $D_{1,1/AB}^g$

In a similar manner to the location and orthogonality specifications of the axis 1,1 of the housing 1, the geometric polytope characterizing the position of the axis 2,1 with respect to the datum reference frame CD result from the intersection of the polytopes  $D_{2,1/CD}^g$  and  $D_{2,1/C}^g$ . This is 4-polytope in which two graphical representations are shown in Fig. 14. Fig. 14a and Fig. 14b represent the projections of 4-polytope in  $(\rho_x, \varepsilon_{P,y})$  and  $(\rho_y, \varepsilon_{P,x})$ .

 Fig. 14. Geometric polytope  $D_{2,1/CD}^g$ 

#### 4.2. Transfer of contact deviations between the parts

Previously geometric deviations of parts were formalised by polytopes. In the following, deviations due to mobility and clearance in the joints will be formalised by polytopes. The joint cover/housing is composed of three elementary joints: a plane pair contact and two ball and cylinder pair contacts. To model the full joint, each of three joints is modelled by a contact polytope.

The planar pair contact between the plane 1,2 cover 2 and the plane 2,2 the housing 2 is without clearance (Fig. 6). The relation (19) characterised the contact without clearance on the whole contour of the contact surface:

$$\begin{cases} \boldsymbol{\varepsilon}_{P-1,2/2,2} \cdot \mathbf{z} = 0 \\ \boldsymbol{\rho}_{1,2/2,2} \cdot \mathbf{x} = 0 \\ \boldsymbol{\rho}_{1,2/2,2} \cdot \mathbf{y} = 0 \end{cases} \quad (19)$$

Relations (20) characterize the limits of displacements between surfaces 1,3 and 2,3 and between surfaces 1,4 and 2,4 of the both ball and cylinder pair contacts (Fig. 6):

$$\begin{cases} -\frac{J}{2} \leq \boldsymbol{\varepsilon}_{E-1,3/2,3} \cdot \mathbf{n}_{\theta_i} \leq \frac{J}{2} \\ -\frac{J}{2} \leq \boldsymbol{\varepsilon}_{F-1,4/2,4} \cdot \mathbf{n}_{\theta_i} \leq \frac{J}{2} \end{cases} \quad (20)$$

with  $\begin{cases} \mathbf{n}_{\theta_i} = \cos \theta_i \cdot \mathbf{x} + \sin \theta_i \cdot \mathbf{y} \\ \theta_i = i \frac{\pi}{n}, 0 \leq i < n \text{ and } (i, n) \in \square \end{cases}$

The maximum clearance corresponds to cases where the diameters of the shafts are smaller and diameters of holes are larger:

$$J = D_{\max\_hole} - D_{\min\_pin} = t_5 + t_6 \quad (21)$$

Relation (20) is expressed according to the rotation vector and the translation vector of the deviation of the point P:

$$\begin{cases} -\frac{J}{2} \leq (\mathbf{EP} \wedge \boldsymbol{\rho}_{1,3/2,3}) \cdot \mathbf{n}_{\theta_i} \leq \frac{J}{2} \\ -\frac{J}{2} \leq (\mathbf{FP} \wedge \boldsymbol{\rho}_{1,4/2,4}) \cdot \mathbf{n}_{\theta_i} \leq \frac{J}{2} \end{cases} \quad (22)$$

with  $\begin{cases} \mathbf{n}_{\theta_i} = \cos \theta_i \cdot \mathbf{x} + \sin \theta_i \cdot \mathbf{y} \\ \theta_i = i \frac{\pi}{n}, 0 \leq i < n \text{ and } (i, n) \in \square \end{cases}$

The polytope of contact characterising the relative position between the housing 1 and the cover 2 results of the intersection between the polytopes defined in (19) and (22). This polytope called  $D_{AB/CD}^c$  is a 3-polytope which a projection in  $(\varepsilon_{p,x}, \varepsilon_{p,y})$  is given in Fig. 15.

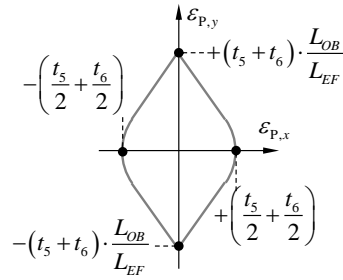

Fig. 15. Polytope of contact  $D_{AB/CD}^c$

### 4.3. Full condition

Geometrical deviations in parts and in contacts were respectively determined in sections 4.2 and 4.3. The relative position between the bore of the housing and the cover will be characterized by the calculated polytope defined by the following Minkoski sum:

$$D_{1,1/2,1} = D_{1,1/AB}^g + D_{AB/CD}^c + D_{CD/2,1}^c \quad (23)$$

The functional polytope  $D_{1,1/2,1}^f$  characterizing the straightness between the bore axis of the cover and the housing is defined by the following relation:

$$D_{1,1/2,1}^f = D_{1,1/ZT}^f + D_{ZT/2,1}^f \quad (24)$$

The geometric polytopes  $D_{1,1/ZT}^f$  and  $D_{2,1/ZT}^f$  characterizing the position of the axis 1,1 and 2,1 with respect to the tolerance zone  $ZT$  are defined by the similar manner to the location of the axis 1,1 (see relation (16)).

The Fig. 16 illustrates the result of the sum of Minskosi (24) characterizing the polytope calculated  $D_{1,1/2,1}$  in  $(\rho_x, \varepsilon_{p,y})$ . On this same figure, the functional polytope  $D_{1,1/2,1}^f$  is shown. To characterize the straightness, the polytope must be included in calculating the functional polytope.

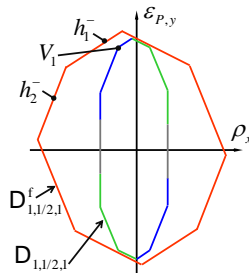

Fig. 16. Inclusion of the calculated polytope  $D_{1,1/2,1}$  in the functional polytope  $D_{1,1/2,1}^f$

If the calculated polytope is included in the functional polytope, the straightness of the two bores is inferior to the value defined in the polytope functional. To determinate the value of straightness of the two bores is necessary to minimize the size of the functional polytope. When the size of the functional polytope is minimum, each vertex of the calculated polytope must be include into each half-spaces of the functional polytope. The straightness is defined by these inequalities:

$$r \geq \frac{E_C}{E_C + L_{BC}} \left[ \frac{t_1}{2} + \frac{t_3}{2} + t_4 \cdot \frac{L_{BC}}{E_C} + (t_5 + t_6) \cdot \frac{L_{OB}}{L_{EF}} \right] \quad (a)$$

$$r \geq \frac{E_C}{E_C + E_H + L_{BC}} \left[ \frac{t_1}{2} + \frac{t_3}{2} + t_4 \cdot \frac{L_{BC} + E_H}{E_C} + (t_5 + t_6) \cdot \frac{L_{OB}}{L_{EF}} \right] \quad (b) \quad (25)$$

$$r \geq \frac{E_H}{E_H + L_{BC}} \left[ \frac{t_1}{2} + \frac{t_3}{2} + t_2 \cdot \frac{L_{BC}}{E_H} + (t_5 + t_6) \cdot \frac{L_{OB}}{L_{EF}} \right] \quad (c)$$

$$r \geq \frac{E_H}{E_H + E_C + L_{BC}} \left[ \frac{t_1}{2} + \frac{t_3}{2} + t_2 \cdot \frac{L_{BC} + E_C}{E_H} + (t_5 + t_6) \cdot \frac{L_{OB}}{L_{EF}} \right] \quad (d)$$

In these four inequalities (25),  $r$  is greater into the relation (a) than into the relation (b) and  $r$  is greater into the relation (c) than into the relation (d). With this method, the straightness value is the same as the previous method (see (13)):

$$r \geq \frac{E_C}{E_C + L_{BC}} \left[ \frac{t_1}{2} + \frac{t_3}{2} + t_4 \cdot \frac{L_{BC}}{E_C} + (t_5 + t_6) \cdot \frac{L_{OB}}{L_{EF}} \right] \quad (26)$$

$$r \geq \frac{E_H}{E_H + L_{BC}} \left[ \frac{t_1}{2} + \frac{t_3}{2} + t_2 \cdot \frac{L_{BC}}{E_H} + (t_5 + t_6) \cdot \frac{L_{OB}}{L_{EF}} \right]$$

## 5. Conclusion

Both methods integrate the influence of the geometrical defects of location and orientation, and the mobility allowed by the clearance in the joints. But they consider directly the situation in the worst case defined by the minimum material condition in the joints and the maximum material condition in the bearings.

For primary planar joint, the analysis line method considers that the datum reference of one part remains in the tolerance zone of the support part. The polytope method neglects the flatness of planes in contact for superimposing the datum reference and the support surface. These two ways of expressing the assumptions lead to the same behavior. This study shows that geometric models are identical, and that the analysis lines means studying the polytope in particular directions. The polytope is more complex, but gives a global view of all degrees of freedom. The method of analysis line is more direct, but requires considering each requirement in several directions by discretization of the ending surface.

Analysis line method directly gives the result as a linear formula of tolerances of influential parts, which subsequently allows to globally optimize the whole system of inequalities to maximize tolerances.

Both methods require a lot of rigor and expertise. A specific tool in CAD system is necessary. The setting-up of parts and functional requirements are described by the designer. The tolerance analysis application collects geometric data and the influential annotations. The calculations can be fully automated to display the result in the form of the numerical value of the result to be compared with the limit value of the requirement.

## References

- [1] P. Clozel, P.-A. Rance, MECAMaster: a Tool for Assembly Simulation from Early Design, Industrial Approach, dans: Geometric tolerancing of products, ISBN 978-1-84821-118-6, ISTE-WILEY, 2010: p. 241-273.
- [2] CETOL.6 <http://www.sigmetrix.com/>
- [3] DCS - Variation Analysis and Tolerance Analysis, [www.3dcs.com](http://www.3dcs.com), 2012.
- [4] Falgarone, H., Chevassus N., 2004, An innovative Design Method and Tool for Structural and Functional Analysis, Proceedings of CIRP Design Seminar, Cairo, Egypt.
- [5] Anselmetti B., 2006, Generation of functional tolerancing based on positioning features, Computer-Aided Design 38 (2006) 902-919
- [5] B. Anselmetti, Generation of functional tolerancing based on positioning features, Computer-Aided Design. 38 (2006) 902-919.
- [6] Anselmetti B., 2009, Part optimization and tolerances synthesis, Int J Adv Manuf Technol, doi 10.1007/s00170-009-2355-6, (2009)
- [7] A. Fleming, Geometric relationships between toleranced features, Artificial Intelligence. 37 (1988) 403-412.
- [8] ISO1101:2013, Geometrical Product Specifications (GPS), Geometrical tolerancing, Tolerances of form, orientation, location and run-out, (2013).
- [9] M. Giordano, E. Pairel, S. Samper, Mathematical representation of tolerance zones, dans: Proc. of 6th CIRP Seminar on Computer Aided Tolerancing - ISBN 0-7923-5654-3, Enschede (Netherlands), 1999.
- [10] U. Roy, B. Li, Representation and interpretation of geometric tolerances for polyhedral objects. II.: Size, orientation and position tolerances, Computer-Aided Design. 31 (1999) 273-285.
- [11] J.K. Davidson, A. Mujezinovic, J.J. Shah, A new mathematical model for geometric tolerances as applied to round faces, ASME Transactions on Journal of Mechanical Design. 124 (2002) 609-622.

- [12] A.D. Fleming, Analysis of Uncertainties and Geometric Tolerances in Assemblies of Parts, PhD thesis, University of Edinburgh, 1987.
- [13] V. Srinivasan, Role of Sweeps in Tolerancing Semantics, in CRTD-Vol. 27, 1993: p. 69-78.
- [14] M. Giordano, D. Duret, Clearance Space and Deviation Space, dans: Proc. of 3rd CIRP seminar on Computer Aided Tolerancing, ISBN 2-212-08779-9, Cachan (France), 1993: p. 179-196.
- [15] D. Teissandier, V. Delos, Operations on polytopes: application to tolerance analysis, dans: Proc. of 6th CIRP Seminar on Computer Aided Tolerancing, ISBN 0-7923-5654-3, Enschede (Netherlands), 1999: p. 425-433.
- [16] Y. Wu, J.J. Shah, J.K. Davidson, Improvements to algorithms for computing the Minkowski sum of 3-polytopes, Computer-Aided Design. 35 (2003) 1181-1192.
- [17] D. Teissandier, V. Delos, Algorithm to calculate the Minkowski sums of 3-polytopes based on normal fans, Computer-Aided Design. 43 (2011) 1567-1576.
- [18] L. Pierre, D. Teissandier, J.P. Nadeau, Integration of thermomechanical strains into tolerancing analysis, Int. J. Interact. Des. Manuf. 3 (2009) 247–263.
- [19] L. Pierre, et al., Variational tolerancing analysis taking thermomechanical strains into account: Application to a high pressure turbine, Mech. Mach. Theory (2014) Current issue,
- [20] Anselmetti B., Chavanne R., Yang J-Y., Anwer N. 2010, Quick GPS:A new CAT system for single-part tolerancing. Computer-Aided Design 42 (2010) 768-780
- [21] Chavanne R., Phd thesis : Contribution au tolérancement fonctionnel 3D des mécanismes complexes : Synthèse des spécifications et Analyse de tolérances, july 2011, ENS Cachan, France.