



HAL
open science

Well-posedness and stability of a 1D wave equation with saturating distributed input

Christophe Prieur, Sophie Tarbouriech, João Manoel Gomes da Silva Gomes da Silva

► To cite this version:

Christophe Prieur, Sophie Tarbouriech, João Manoel Gomes da Silva Gomes da Silva. Well-posedness and stability of a 1D wave equation with saturating distributed input. CDC 2014 - 53rd IEEE Conference on Decision and Control, Dec 2014, Los Angeles, United States. pp. 2846-2851, <10.1109/CDC.2014.7039826>. <hal-01235418>

HAL Id: hal-01235418

<https://hal.science/hal-01235418v1>

Submitted on 30 Nov 2015

HAL is a multi-disciplinary open access archive for the deposit and dissemination of scientific research documents, whether they are published or not. The documents may come from teaching and research institutions in France or abroad, or from public or private research centers.

L'archive ouverte pluridisciplinaire HAL, est destinée au dépôt et à la diffusion de documents scientifiques de niveau recherche, publiés ou non, émanant des établissements d'enseignement et de recherche français ou étrangers, des laboratoires publics ou privés.



HAL Authorization

Well-posedness and stability of a 1D wave equation with saturating distributed input

Christophe Prieur, Sophie Tarbouriech and João M. Gomes da Silva Jr

Abstract—In this paper, it is considered a wave equation with a one-dimensional space variable, which describes the dynamics of string deflection. The slope has a finite length and is attached at both boundaries. It is equipped with a distributed actuator subject to a saturation. By closing the loop with a saturating input proportional to the speed of the deformation, it is thus obtained a nonlinear partial differential equation, which is the generalization of the classical 1D wave equation. The well-posedness is proven by using nonlinear semigroups technics. The asymptotic stability of the closed-loop system, when the tuning parameter has a suitable sign, is proven by Lyapunov technics and a sector condition describing the saturating input.

I. INTRODUCTION

The general problem in this paper is the study of the wave in a one-dimensional media, as considered e.g. when modeling the dynamics of an elastic slope vibrating around its rest position. To be more specific, it is assumed that the slope is attached to both extremities (implying that the deformations is zero at both ends of the slope), is vibrating in a plane and that the slope is subject to an external force in this plane. See Figure 1 for an illustration of the physical motivation of this study, where the deformation is denoted by $z(x, t)$, the external force is $af(x, t)$ (a is a scaling factor), and where the force may depend on the space and the time variables.

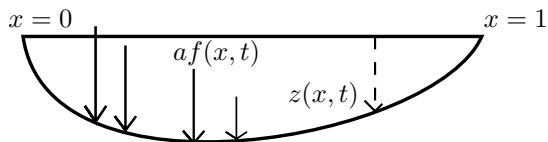

Fig. 1. Vibrating slope subject to an external force

The dynamic of the vibration is described by the following 1D wave equation (see e.g. [15, Chapter 5.3]) written as, for all $t \geq 0$, $x \in (0, 1)$,

$$z_{tt}(x, t) = z_{xx}(x, t) + af(x, t) \quad (1)$$

C. Prieur is with Department of Automatic Control, Gipsa-lab, 961 rue de la Houille Blanche, BP 46, 38402 Grenoble Cedex, France, christophe.prieur@gipsa-lab.fr

S. Tarbouriech is with CNRS, LAAS, 7 avenue du colonel Roche, F-31400 Toulouse, France and Univ de Toulouse, LAAS, F-31400 Toulouse, France. tarbour@laas.fr.

J.M. Gomes da Silva Jr is with the Department of Electrical Engineering, UFRGS, 90035-190 Porto Alegre-RS, Brazil, jmgomes@ece.ufrgs.br

This work was supported by CAPES-COFECUB "Ma 590/08" and by STIC-AmSud "ADNEC" projects.

where z stands for the state, $z(x, t) \in \mathbb{R}$ is the deflection of the string with respect to the rest position at time t and at position $x \in (0, 1)$ (the length of the string and other physical parameters are normalized), f is the control, $f(x, t) \in \mathbb{R}$, and a is a constant value. The control f is distributed (in contrast to boundary control, and is given by a bounded control operator). Let us equip this system with the following boundary conditions, for all $t \geq 0$,

$$\begin{aligned} z(0, t) &= 0, \\ z(1, t) &= 0, \end{aligned} \quad (2)$$

and with the following initial condition, for all x in $(0, 1)$

$$\begin{aligned} z(x, 0) &= z^0(x), \\ z_t(x, 0) &= z^1(x), \end{aligned} \quad (3)$$

where z^0 and z^1 stand respectively for the initial deflection of the slope and the initial deflection speed.

When closing the loop with a linear state feedback law, the control problem of such a 1D wave equation is considered in many works, see e.g. [8] where in particular stabilizing linear controllers and optimal linear feedback laws are computed respectively by an application of linear semigroup theory and LQR technics. The aim of this paper is to investigate the well-posedness and the asymptotic stability of this partial differential equation (PDE) by means of saturating inputs.

In presence of saturating inputs, neglecting the amplitude actuator limitation in the closed-loop systems can be source of undesirable and even catastrophic behaviors for the closed-loop system, such as instability, even for finite-dimensional system (see e.g., [4]). For an introduction of such nonlinear finite dimensional systems and technics on how to estimate the basin of attraction for locally asymptotically stable equilibrium, see [21], [23] among other references. One useful ingredient when considering such systems is the Lyapunov theory and a sector condition of the saturation map, as introduced in [9]. This allows to compute strict Lyapunov functions estimating the basin of attraction.

However, to our best knowledge, the well-posedness and the asymptotic stability of PDE in presence of a saturation in the loop is less investigated than for corresponding finite dimensional systems. This is the aim of this work, where the nonlinear semigroup theory is applied to rigorously prove the existence and uniqueness of weak and strong solutions to the PDE (1) with the boundary conditions (2), with initial conditions (3) in appropriate Sobolev spaces, when closing the loop with saturating inputs. Assuming a suitable sign of the scaling factor, the second contribution is to prove the global asymptotic stability of the closed-loop system by

using a sector condition for the saturation (as in [14], [21]), and computing a Lyapunov function. In other words, this paper combines technics that are usual for finite dimensional systems equipped with saturating input (see e.g. [12], [22]) and Lyapunov theory for PDEs (see e.g. [11], [5]).

The rest of the paper is organized as follows. In Section II, the nonlinear PDE under study in this paper is introduced, and the main result is stated, namely the well-posedness of the Cauchy problem, together with the global asymptotic stability. The proof of this contribution is given in Section III. Some concluding remarks and possible further research lines are collected in Section V. Section IV contains some numerical simulations to illustrate the main result.

Notation: z_t (resp. z_x) stands for the partial derivative of the function z with respect to t (resp. x) (this is a shortcut for $\frac{\partial z}{\partial t}$, resp. $\frac{\partial z}{\partial x}$). When there is only one independent variable, \dot{z} and z' stand respectively for the time and the space derivative. For a matrix A , A^\top denotes the transpose, and for a partitioned symmetric matrix, the symbol \star stands for symmetric block. $\Re(s)$ and $\Im(s)$ stand respectively for the real and imaginary part of a complex value s in \mathbb{C} , \bar{s} is the conjugate of s , and $|s|$ its modulus. $\|\cdot\|_{L^2}$ denotes the norm in $L^2(0,1)$ space, defined by $\|u\|_{L^2(0,1)}^2 = \int_0^1 |u|^2 dx$ for all functions $u \in L^2(0,1)$. Similarly, $H^2(0,1)$ is the set of all functions $u \in H^2(0,1)$ such that $\int_0^1 (|u|^2 + |u_x|^2 + |u_{xx}|^2) dx$ is finite. Finally $H_0^1(0,1)$ is the closure in $L^2(0,1)$ of the set of smooth functions that are vanishing at $x=0$ and at $x=1$. It is equipped with the norm $\|u\|_{H_0^1(0,1)}^2 = \int_0^1 |u_x|^2 dx$. The associate inner products are denoted $\langle \cdot, \cdot \rangle_{L^2(0,1)}$ and $\langle \cdot, \cdot \rangle_{H_0^1(0,1)}$.

II. STRING EQUATION WITH A SATURATED ACTION

Consider the PDE (1), with the boundary conditions (2) and the initial condition (3).

Letting for the control, for all $t \geq 0$ and all $x \in (0,1)$,

$$f(x,t) = z_t(x,t), \quad (4)$$

and exploiting properties of the following energy function:

$$E = \frac{1}{2} \int (z_x^2 + z_t^2) dx, \quad (5)$$

for any solution z to (1) and (2), when closing the loop with the linear controller (4), the closed-loop system is (globally) exponentially stable in $H_0^1(0,1) \times L^2(0,1)$. More precisely, using standard technics (see [8] for the existence issue and [13], [19] for the exponential stability), we may prove the following

Proposition 2.1: *For any initial conditions (z^0, z^1) in $(H^2(0,1) \cap H_0^1(0,1)) \times H_0^1(0,1)$, there exists a unique strong continuous solution $z: [0, \infty) \rightarrow H^2(0,1) \cap H_0^1(0,1)$ (endowed with the $H^2(0,1)$ norm) to (1), (2), (3) and (4), continuously differentiable from $[0, \infty)$ to $H_0^1(0,1)$.*

For any initial conditions (z^0, z^1) in $H_0^1(0,1) \times L^2(0,1)$, there exists a unique weak solution $z: [0, \infty) \rightarrow H_0^1(0,1)$ to (1), (2), (3) and (4).

Moreover, if a is negative ($a < 0$), then, there exist $C > 0$ and $\gamma > 0$, such that, for any initial conditions $H_0^1(0,1) \times$

$L^2(0,1)$, the weak solution z to (1), (2), (3) and (4) satisfies, for all $t \geq 0$,

$$\begin{aligned} & \|z\|_{H_0^1(0,1)} + \|z_t\|_{L^2(0,1)} \\ & \leq C e^{-\gamma t} (\|z_0\|_{H_0^1(0,1)} + \|z_1\|_{L^2(0,1)}). \end{aligned} \quad (6)$$

This result is not our main contribution, but it will be instrumental for the proof of our main result (namely, Theorem 2.2 below). Due to space limitation, the proof of this result is omitted.

To formally prove Proposition 2.1, let us perform a computation. Along the solutions to (1) and (2), it yields (at least formally),

$$\begin{aligned} \dot{E} &= \int_0^1 (z_x z_{xt} + a z_t^2 + z_t z_{xx}) dx \\ &= \int_0^1 a z_t^2 dx + [z_t z_x]_{x=0}^{x=1} \\ &= \int_0^1 a z_t^2 dx \end{aligned}$$

by using an integration by parts to get the second line from the first one, and the boundary conditions (2) for the last line. Therefore, for any negative value a , it is formally obtained that the energy is decreasing at long as z_t is non vanishing in $[0,1]$. In other words, E is a (non strict) Lyapunov function.

Due to actuator limitation, it is rather natural to introduce a saturation function sat of level u_0 , and to define the control as, for all $t \geq 0$, for all $x \in (0,1)$,

$$f(x,t) = \text{sat}(z_t(x,t)) \quad (7)$$

instead of (4).

Equation (1) in closed loop with the control (7) becomes

$$z_{tt} = z_{xx} + a z_t + a \varphi(z_t) \quad (8)$$

where the deadzone function $\varphi(s) := \text{sat}(s) - s$, for all s in \mathbb{R} , has been used.

A formal computation gives, along the solutions to (8) and (2),

$$\dot{E} = \int_0^1 a z_t^2 dx + \int_0^1 a z_t \varphi(z_t) dx \quad (9)$$

which asks to handle the nonlinearity $z_t \varphi(z_t)$. The convergence result is stated in the following result, where the well-posedness is separate to the asymptotic stability property.

Theorem 2.2: *For all negative values a , the model (8) with the boundary conditions (2) is globally asymptotically stable. More precisely the following properties hold:*

- [Well-posedness] *Given any $a \in \mathbb{R}$, for all (z^0, z^1) in $(H^2(0,1) \cap H_0^1(0,1)) \times H_0^1(0,1)$, there exists a unique continuous strong solution $z: [0, \infty) \rightarrow H^2(0,1) \cap H_0^1(0,1)$ to (8) with the boundary conditions (2) and the initial condition (3), that is continuously differentiable from $[0, \infty)$ to $H_0^1(0,1)$.*

- *For all (z^0, z^1) in $H_0^1(0,1) \times L^2(0,1)$, there exists a unique continuous weak solution $z: [0, \infty) \rightarrow H_0^1(0,1)$ to (8) with the boundary conditions (2) and the initial condition (3).*

- [Global asymptotic stability] *Moreover, if a is negative, for all initial conditions in (z^0, z^1) in $H_0^1(0,1) \times L^2(0,1)$, the weak solution to (8) with the boundary conditions (2)*

and the initial condition (3) satisfies the following stability property

$$\begin{aligned} & \|z(\cdot, t)\|_{H_0^1(0,1)} + \|z_t(\cdot, t)\|_{L^2(0,1)} \\ & \leq \|z^0\|_{H_0^1(0,1)} + \|z^1\|_{L^2(0,1)}, \quad \forall t \geq 0, \end{aligned} \quad (10)$$

together with the attractivity property

$$\|z(\cdot, t)\|_{H_0^1(0,1)} + \|z_t(\cdot, t)\|_{L^2(0,1)} \rightarrow 0, \quad \text{as } t \rightarrow \infty. \quad (11)$$

III. PROOF OF THEOREM 2.2

Proof: The proof of Theorem 2.2 is split into two parts: 1) the Cauchy problem has a unique solution, 2) the system is globally asymptotically stable.

Part 1: Well-posedness of the Cauchy problem (8), (2), (3).

Let us first prove the existence and unicity of weak and strong solutions to the nonlinear equation (8) with the boundary conditions (2) and the initial condition (3). To do that, let us introduce the following nonlinear operator

$$A \begin{pmatrix} u \\ v \end{pmatrix} = \begin{pmatrix} v \\ u_{xx} + a \text{sat}(v) \end{pmatrix}$$

with the domain $D(A) = (H^2(0,1) \cap H_0^1(0,1)) \times H_0^1(0,1)$.

To prove the well-posedness of the Cauchy problem, we shall state that A generates a semigroup of contractions by applying [2, Theo. 1.3, Page 104], and thus we need to prove that A is closed, dissipative, and satisfies a range condition (see (15) below). Let us prove these properties successively.

The nonlinear operator A is closed in the sense of [17, Def. 2.6], that is, if $\begin{pmatrix} u_n \\ v_n \end{pmatrix}_{n \in \mathbb{N}}$ is a sequence in $D(A)$, such that $\lim_{n \rightarrow \infty} \begin{pmatrix} u_n \\ v_n \end{pmatrix} = \begin{pmatrix} u \\ v \end{pmatrix}$ and such that $\lim_{n \rightarrow \infty} A \begin{pmatrix} u_n \\ v_n \end{pmatrix} = \begin{pmatrix} \tilde{u} \\ \tilde{v} \end{pmatrix}$, then it holds $A \begin{pmatrix} u \\ v \end{pmatrix} = \begin{pmatrix} \tilde{u} \\ \tilde{v} \end{pmatrix}$.

Moreover, following the terminology of [17, Definition 2.4], and using the nonpositivity of a , we may prove the following lemma.

Lemma 3.1: *A is a dissipative operator.*

Proof of Lemma 3.1: In the following, \prime stands for the derivative with respect to the space variable. Let us first denote by H the space $H_0^1(0,1) \times L^2(0,1)$. It is a Hilbert space equipped with the inner product

$$\left\langle \begin{pmatrix} u \\ v \end{pmatrix}, \begin{pmatrix} \tilde{u} \\ \tilde{v} \end{pmatrix} \right\rangle = \int_0^1 u'(x) \overline{\tilde{u}'(x)} dx + \int_0^1 v(x) \overline{\tilde{v}(x)} dx, \quad (12)$$

and the norm

$$\left\| \begin{pmatrix} u \\ v \end{pmatrix} \right\| = \sqrt{\int_0^1 |u'(x)|^2 dx + \int_0^1 |v(x)|^2 dx}.$$

Let us enlarge the domain of definition of the deadzone function sat to the complex numbers, by letting, for all $s \in \mathbb{C}$,

$$\text{sat}_{\mathbb{C}}(s) := \text{sat}(\Re(s)) + i \text{sat}(\Im(s)).$$

To ease the notation, we still use sat instead of $\text{sat}_{\mathbb{C}}$. We define φ for complex numbers in a similar way.

To check that A is dissipative, using first the definition of A and then recalling the definition of the inner product (12), let us compute the following, for all $\begin{pmatrix} u \\ v \end{pmatrix}, \begin{pmatrix} \tilde{u} \\ \tilde{v} \end{pmatrix}$ in $D(A)$

$$\begin{aligned} & \left\langle A \begin{pmatrix} u \\ v \end{pmatrix} - A \begin{pmatrix} \tilde{u} \\ \tilde{v} \end{pmatrix}, \begin{pmatrix} u \\ v \end{pmatrix} - \begin{pmatrix} \tilde{u} \\ \tilde{v} \end{pmatrix} \right\rangle \\ & = \left\langle \begin{pmatrix} v - \tilde{v} \\ u'' + a \text{sat}(v) - \tilde{u}'' - a \text{sat}(\tilde{v}) \end{pmatrix}, \begin{pmatrix} u - \tilde{u} \\ v - \tilde{v} \end{pmatrix} \right\rangle, \\ & = \int_0^1 (v - \tilde{v})'(x) \overline{(u - \tilde{u})'(x)} dx \\ & + \int_0^1 [(u'' + a \text{sat}(v)) - (\tilde{u}'' + a \text{sat}(\tilde{v}))](x) \\ & \quad \times \overline{(v - \tilde{v})(x)} dx, \\ & = \int_0^1 (v - \tilde{v})'(x) \overline{(u - \tilde{u})'(x)} dx \\ & + \int_0^1 (u'' - \tilde{u}'')(x) \overline{(v - \tilde{v})(x)} dx \\ & + \int_0^1 a(\text{sat}(v) - \text{sat}(\tilde{v}))(x) \overline{(v - \tilde{v})(x)} dx. \end{aligned} \quad (13)$$

Consider the second integral in the last equation. Performing an integration by parts and using the definition of $D(A)$, it gives

$$\begin{aligned} & \int_0^1 (u'' - \tilde{u}'')(x) \overline{(v - \tilde{v})(x)} dx \\ & = - \int_0^1 (u' - \tilde{u}')(x) \overline{(v' - \tilde{v}')(x)} dx \\ & + [(u' - \tilde{u}')(x) \overline{(v - \tilde{v})(x)}]_{x=0}^{x=1} \\ & = - \int_0^1 (u' - \tilde{u}')(x) \overline{(v' - \tilde{v}')(x)} dx \end{aligned}$$

Thus, with (13), it follows

$$\begin{aligned} & \Re \left(\left\langle A \begin{pmatrix} u \\ v \end{pmatrix} - A \begin{pmatrix} \tilde{u} \\ \tilde{v} \end{pmatrix}, \begin{pmatrix} u \\ v \end{pmatrix} - \begin{pmatrix} \tilde{u} \\ \tilde{v} \end{pmatrix} \right\rangle \right) \\ & = \Re \left(\int_0^1 (v - \tilde{v})'(x) \overline{(u - \tilde{u})'(x)} dx \right) \\ & - \Re \left(\int_0^1 (u' - \tilde{u}')(x) \overline{(v' - \tilde{v}')(x)} dx \right) \\ & + a \Re \left(\int_0^1 (\text{sat}(v) - \text{sat}(\tilde{v}))(x) \overline{(v - \tilde{v})(x)} dx \right), \\ & = a \Re \left(\int_0^1 (\text{sat}(v) - \text{sat}(\tilde{v}))(x) \overline{(v - \tilde{v})(x)} dx \right). \end{aligned} \quad (14)$$

Now let us note that, for all $(s, \tilde{s}) \in \mathbb{C}$,

$$\Re \left((\text{sat}(s) - \text{sat}(\tilde{s})) \overline{(s - \tilde{s})} \right) \geq 0.$$

Therefore it follows, from (14) and the nonpositivity of a ,

$$\Re \left(\left\langle A \begin{pmatrix} u \\ v \end{pmatrix} - A \begin{pmatrix} \tilde{u} \\ \tilde{v} \end{pmatrix}, \begin{pmatrix} u \\ v \end{pmatrix} - \begin{pmatrix} \tilde{u} \\ \tilde{v} \end{pmatrix} \right\rangle \right) \leq 0,$$

and thus A is dissipative. \square

Let us now show that the operator A generates a semigroup of contractions. To do that, we apply [2, Theo. 1.3, Page 104] (or [17, Theo. 4.2, Page 77]) and we need to prove that

$$D(A) \subset \text{Ran}(I - \lambda A) \quad (15)$$

for all $\lambda > 0$ sufficiently small, where $\text{Ran}(I - \lambda A)$ is the range of the operator $I - \lambda A$. To prove (15), let us pick $\begin{pmatrix} u \\ v \end{pmatrix}$ in $D(A)$ and let us prove that there exists $\begin{pmatrix} \tilde{u} \\ \tilde{v} \end{pmatrix}$

in $D(A)$ such that $(I - \lambda A) \begin{pmatrix} \tilde{u} \\ \tilde{v} \end{pmatrix} = \begin{pmatrix} u \\ v \end{pmatrix}$. Let us first note that this latter equation is equivalent to

$$\begin{cases} \tilde{u} - \lambda \tilde{v} = u, \\ \tilde{v} - \lambda(\tilde{u}'' + a \text{sat}(\tilde{v})) = v, \end{cases}$$

which may be rewritten as

$$\begin{cases} \tilde{v} = \frac{1}{\lambda}(\tilde{u} - u) \\ \tilde{u}'' - \frac{1}{\lambda^2}\tilde{u} + a \text{sat}(\frac{1}{\lambda}(\tilde{u} - u)) = -\frac{1}{\lambda}v - \frac{1}{\lambda^2}u \end{cases} \quad (16)$$

To check that there exists $\tilde{u} \in H^2(0,1) \cap H_0^1(0,1)$ such that the second line of (16) holds, let us first note that this is a nonhomogeneous nonlinear differential equation in the \tilde{u} -variable with two boundary conditions (at $x = 0$ and at $x = 1$), as considered in the following:

Lemma 3.2: *If a is nonpositive and λ is positive, then there exists $\tilde{u} \in H^2(0,1) \cap H_0^1(0,1)$ solution to*

$$\begin{aligned} \tilde{u}'' - \frac{1}{\lambda^2}\tilde{u} + a \text{sat}(\frac{1}{\lambda}(\tilde{u} - u)) &= -\frac{1}{\lambda}v - \frac{1}{\lambda^2}u \\ \tilde{u}(0) &= \tilde{u}(1) = 0 \end{aligned} \quad (17)$$

Proof of Lemma 3.2: The proof of this lemma follows from classical technics (see e.g., [17, Page 113], or [5, Page 179]) and uses the Schauder fixed-point theorem (see e.g., [5, Theo. B.19]). Let us give only the sketch of the proof of this lemma.

To prove this lemma, let us introduce the following map

$$\begin{aligned} \mathcal{T} : L^2(0,1) &\rightarrow L^2(0,1), \\ y &\mapsto z = \mathcal{T}(y), \end{aligned}$$

where $z = \mathcal{T}(y)$ is the unique solution to

$$\begin{aligned} z'' - \frac{1}{\lambda^2}z &= -\frac{1}{\lambda}v - \frac{1}{\lambda^2}u - a \text{sat}(\frac{1}{\lambda}(y - u)), \\ z(0) &= z(1) = 0. \end{aligned} \quad (18)$$

This map \mathcal{T} is well defined as soon as $-\frac{1}{\lambda^2} \leq 0$, i.e. as soon as $\lambda > 0$.

Moreover, there exists $M > 0$ such that $\mathcal{T}(L^2(0,1)) \subset K$, where K is the set of functions w that are continuously differentiable on $[0,1]$ and such that $\|w\|_{C^0([0,1])} \leq M$ and $\|w'\|_{C^0([0,1])} \leq M$. Moreover \mathcal{T} is a continuous operator. Finally the set K is convex and compact (by the Ascoli-Arzelà theorem), as a subset of $L^2(0,1)$.

Therefore, by the Schauder fixed-point theorem (see e.g., [5, Theorem B.19]), there exists $\tilde{u} \in K$ such that $\mathcal{T}(\tilde{u}) = \tilde{u}$. This concludes the proof of Lemma 3.2. \square

Now from the existence of $\tilde{u} \in H_0^2(0,1)$ such that the second line of (16) holds, let us remark that the first line of (16) defines a unique \tilde{v} in $H_0^1(0,1)$. Therefore $(I - \lambda A) \begin{pmatrix} \tilde{u} \\ \tilde{v} \end{pmatrix} = \begin{pmatrix} u \\ v \end{pmatrix}$ and (15) hold.

Since A is dissipative (due to Lemma 3.1), it follows, from [2, Theo. 1.3, Page 104] (or [17, Theo. 4.2]), that A generates a semigroup of contractions $T(t)$. Moreover, by [2, Theo. 1.2, Page 102] (or [17, Theo. 4.5]), for all $\begin{pmatrix} \tilde{u} \\ \tilde{v} \end{pmatrix}$ in $D(A)$, $T(t) \begin{pmatrix} \tilde{u} \\ \tilde{v} \end{pmatrix}$ is strongly differentiable for all $t > 0$ and is a strong solution to the Cauchy Problem (8), (2) and (3). Moreover due to [17, Theo. 4.10], it is the unique strong solution to this Cauchy problem.

The existence and the uniqueness of the weak solution in $H = H_0^1(0,1) \times L^2(0,1)$ to the Cauchy problem (8), (2) and (3) follow from e.g. [3, Theorem 3.1, page 54] and [1, Theorem 2.2]).

Another (more involved) proof of the well-posedness of the Cauchy problem (8), (2) and (3), for strong solutions, is to apply [2, Theo. 1.1, Page 268].

Part 2: Global asymptotic stability of the nonlinear equation (8) with the boundary conditions (2).

Let us consider a strong solution to (8) and (2), for a given initial condition in $D(A)$. The formal computation yielding (9) makes sense. To handle the nonlinearity in (9), the following result will be instrumental for the global stability analysis and is recalled below (see e.g., [21, Chapter 1] for a proof and also [14, Chapter 7]).

Lemma 3.3: *([21]) For all s in \mathbb{R} , the nonlinearity $\varphi(s)$ satisfies the following inequality:*

$$\varphi(s)(\varphi(s) + s) \leq 0. \quad (19)$$

Using Lemma 3.3 with $s = z_t$, and recalling the computation (9), it yields, for any negative value b , $\dot{E} \leq \mathcal{L}$, where \mathcal{L} is defined by

$$\begin{aligned} \mathcal{L} &= \dot{E} + \int_0^1 b(\varphi(z_t))^2 + \varphi(z_t)z_t dx \\ &= \int_0^1 \begin{pmatrix} z_t \\ \varphi(z_t) \end{pmatrix}^\top \begin{pmatrix} a & \frac{a+b}{2} \\ \star & b \end{pmatrix} \begin{pmatrix} z_t \\ \varphi(z_t) \end{pmatrix} dx \end{aligned}$$

Since a and b are negative, the matrix $\begin{pmatrix} a & \frac{a+b}{2} \\ \star & b \end{pmatrix}$ is negative semi-definite, if and only if its determinant is non-positive, that is $ab - \frac{b^2}{4} - \frac{ab}{2} - \frac{a^2}{4} \geq 0$. Moreover, with $a = b$, we get that $\begin{pmatrix} a & \frac{a+b}{2} \\ \star & b \end{pmatrix}$ is negative semi-definite (its determinant is 0), and thus we get $\mathcal{L} \leq 0$, along the strong solutions to (8) and (2), for any initial condition in $D(A)$.

To be able to apply LaSalle's Invariance Principle, we have to check that the trajectories are precompact (see e.g. [10]). This precompactness is a corollary of the following lemma (which is very similar to [11, Lemma 2] with different boundary condition).

Lemma 3.4: *The canonical embedding from $D(A)$, equipped with the graph norm, into H is compact.*

Proof of Lemma 3.4: Before proving this lemma, recall that its statement is equivalent to prove, for each sequence in $D(A)$, which is bounded with the graph norm, that it exists a subsequence that (strongly) converges in H .

Recalling the definition of the graph norm, it holds, for all $\begin{pmatrix} u \\ v \end{pmatrix}$ in $D(A)$,

$$\begin{aligned} \left\| \begin{pmatrix} u \\ v \end{pmatrix} \right\|_{D(A)}^2 &:= \left\| \begin{pmatrix} u \\ v \end{pmatrix} \right\|^2 + \left\| A \begin{pmatrix} u \\ v \end{pmatrix} \right\|^2, \\ &= \int_0^1 (|u'|^2 + |v|^2 + |v'|^2 \\ &\quad + |u'' + a \text{sat}(v)|^2) dx. \end{aligned}$$

Therefore, on the one hand, one gets

$$\left\| \begin{pmatrix} u \\ v \end{pmatrix} \right\|_{D(A)}^2 \geq \int_0^1 (|v|^2 + |v'|^2) dx, \quad (20)$$

and on the other hand, since $|v| \geq \min(1, \frac{1}{a}) |asat(v)|$ and $|u'' + asat(v)| \geq \min(1, \frac{1}{a}) |u'' + asat(v)|$, it holds

$$\left\| \begin{pmatrix} u \\ v \end{pmatrix} \right\|_{D(A)}^2 \geq \int_0^1 (|u'|^2 + \min(1, \frac{1}{a^2}) |asat(v)|^2 + \min(1, \frac{1}{a^2}) |u'' + asat(v)|^2) dx.$$

Since, for all $(s, \bar{s}) \in \mathbb{C}^2$, it holds $|s + \bar{s}|^2 \leq 2|s|^2 + 2|\bar{s}|^2$, it follows $2|u'' + asat(v)|^2 + 2|asat(v)|^2 \geq |u''|^2$ and thus

$$\begin{aligned} \left\| \begin{pmatrix} u \\ v \end{pmatrix} \right\|_{D(A)}^2 &\geq \int_0^1 (|u'|^2 + \min(\frac{1}{2}, \frac{1}{2a^2}) |u''|^2) dx, \\ &\geq \min(\frac{1}{2}, \frac{1}{2a^2}) \int_0^1 (|u'|^2 + |u''|^2) dx. \end{aligned} \quad (21)$$

Consider now a sequence $\left(\begin{pmatrix} u_n \\ v_n \end{pmatrix} \right)_{n \in \mathbb{N}}$ in $D(A)$ bounded for the graph norm of $D(A)$. From (20) and (21), it follows that this sequence is bounded in the product space $H_0^2(0,1) \times H^1(0,1)$, where $H_0^2(0,1)$ is the set of functions in $H^2(0,1)$ vanishing at $x=0$ and at $x=1$. Since the canonical embedding from $H_0^2(0,1)$ to $H_0^1(0,1)$ (resp. from $H^1(0,1)$ to $L^2(0,1)$) is compact, there exists a subsequence still denoted $\left(\begin{pmatrix} u_n \\ v_n \end{pmatrix} \right)_{n \in \mathbb{N}}$ such that $u_n \rightarrow u$ in $H_0^1(0,1)$, $v_n \rightarrow v$ in $L^2(0,1)$, and thus $\begin{pmatrix} u \\ v \end{pmatrix}$ belongs to H , which proves the lemma. \square

Using the dissipativity (see Lemma 3.1), we get, for all $t \geq 0$,

$$\left\| \begin{pmatrix} z(\cdot, t) \\ z_t(\cdot, t) \end{pmatrix} \right\| \leq \left\| \begin{pmatrix} z(\cdot, 0) \\ z_t(\cdot, 0) \end{pmatrix} \right\|.$$

Therefore with Lemma 3.4, the trajectory $\left(\begin{pmatrix} z(\cdot, t) \\ z_t(\cdot, t) \end{pmatrix} \right)$ is precompact in H , then the ω -limit set $\omega \left[\begin{pmatrix} z(\cdot, 0) \\ z_t(\cdot, 0) \end{pmatrix} \right] \subset D(A)$, is not empty and invariant with respect to the nonlinear semigroup $T(t)$ (see [20, Theorem 3.1]).

We now use LaSalle's invariance principle to show that $\omega \left[\begin{pmatrix} z(\cdot, 0) \\ z_t(\cdot, 0) \end{pmatrix} \right] = \{0\}$. To do that, consider a strong solution such that $\dot{E}(t) = 0$, for all $t \geq 0$. It follows from (9) that $z_t(x, t) = 0$ for almost all x in $(0,1)$ and thus the absolute value of z_t is smaller than the level of the saturation map, namely $|z_t| \leq u_0$, and thus for sufficiently large time, z is a solution to the linear equation (1) with the boundary conditions (2), which is asymptotically stable, as stated in Proposition 2.1. Therefore the convergence property (11) holds along the strong solutions to the nonlinear equation (8) with the boundary conditions (2).

Using the density of $D(A)$ and the existence of weak solutions, we end the proof by extending the result to any initial condition in H .

This concludes the proof of Theorem 2.2. \blacksquare

IV. NUMERICAL SIMULATIONS

To illustrate Theorem 2.2, let us discretize the PDE (8) with the boundary conditions (2) by means of finite difference method, solving for all the values of z at the next time step by using the values known at the previous two time steps (see e.g. [16] for an introduction on the numerical implementation). It is chosen the time and the space steps so that the stability condition of the numerical scheme is satisfied. Let us consider the initial condition (3) with $z^0(x) = \sin(2\pi x)$ and $z^1(x) = 0$, for all $x \in [0,1]$. With the value $a = -0.1$ and the level of the saturation $u_0 = 5$, the time evolution of the numerically computed z -component of the solution is given in Figure 2 where it is checked that it converges to the equilibrium. See also Figure 3 where it is observed that the control input saturates for small time.

Let us now select a lower saturation level: $u_0 = 1$. It is checked on Figure 4 that the z -component of the solution still converges to the origin but it takes more time to converge around the equilibrium. See also Figure 5 for the time evolution of the saturating input, where it is checked that the saturation map applies for longer time than with $u_0 = 5$ (compare with Figure 3).

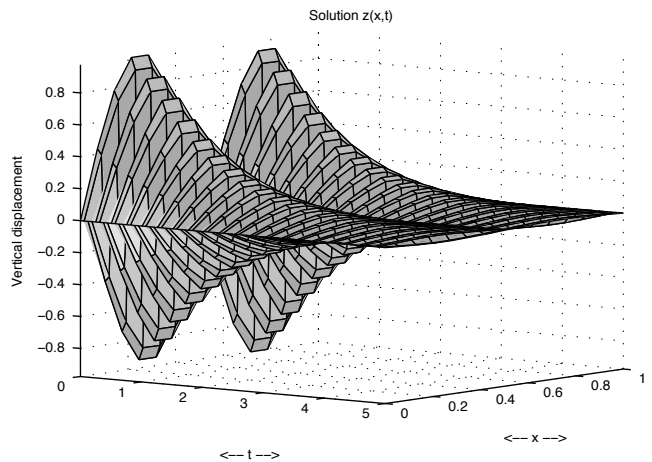

Fig. 2. Time evolution of the z -component of the solution to (8), (2) and (3) with $u_0 = 5$.

V. CONCLUSION

It has been studied the well-posedness and the asymptotic stability of a class of 1D wave equation. The PDE under consideration resulted from the loop of a classical string equation with a saturating distributed input. The well-posedness issue has been tackled by using nonlinear semigroup technics and the stability has been proven by using a sector condition, and Lyapunov theory for infinite dimensional systems.

This work lets many questions open. In particular, it could be interesting to considering other PDEs useful in vibration control theory, such as the beam equation. As an example, the study of the saturation map on pointwise control of the

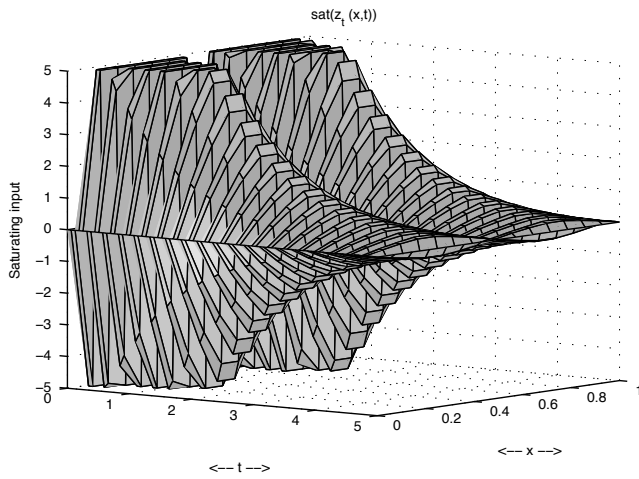

Fig. 3. Time evolution of the saturating input with $u_0 = 5$.

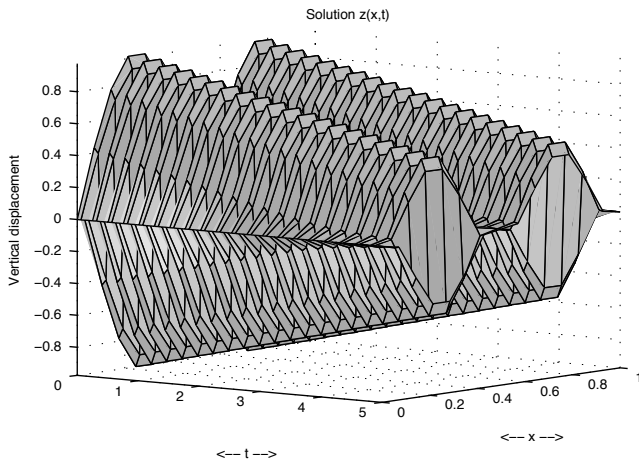

Fig. 4. Time evolution of the z -component of the solution to (8), (2) and (3) with $u_0 = 1$.

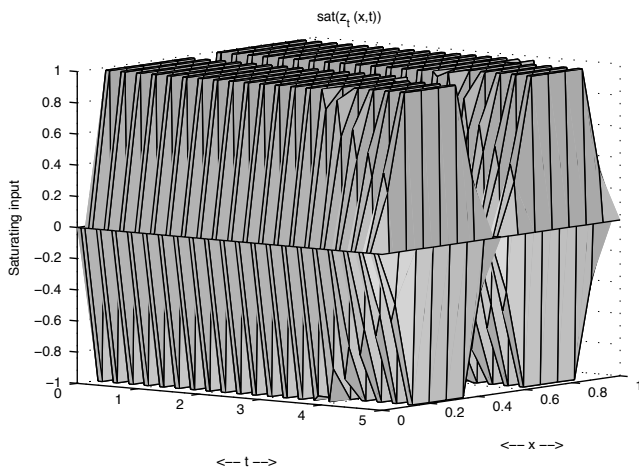

Fig. 5. Time evolution of the saturating input with $u_0 = 1$.

beam equation (as considered in [7]) shall be tackled. Other hyperbolic systems as the one considered in this paper may be also considered as the conservation laws that are useful for the flow control (see [6], [18]). For such a class of PDEs, Lyapunov theory is an useful tool when designing stabilizing linear controllers, and may be also the key when computing saturating stabilizing feedback laws. Generalization to 2D PDE is also a natural research line.

REFERENCES

- [1] J.M. Ball and M. Slemrod. Feedback stabilization of distributed semilinear control systems. *Applied Mathematics and Optimization*, 5(1):169–179, 1979.
- [2] V. Barbu. *Nonlinear semigroups and differential equations in Banach spaces*. Editura Academiei, 1976.
- [3] H. Brezis. *Opérateurs maximaux monotones et semi-groupes de contractions dans les espaces de Hilbert*. North-Holland, 1973.
- [4] P.J. Campo and M. Morari. Robust control of processes subject to saturation nonlinearities. *Computers & Chemical Engineering*, 14(4–5):343 – 358, 1990.
- [5] J.-M. Coron. *Control and Nonlinearity*, volume 136 of *Mathematical Surveys and Monographs*. American Mathematical Society, Providence, RI, 2007.
- [6] J.-M. Coron, B. d’Andréa Novel, and G. Bastin. A strict Lyapunov function for boundary control of hyperbolic systems of conservation laws. *IEEE Transactions on Automatic Control*, 52(1):2–11, 2007.
- [7] E. Crépeau and C. Prieur. Control of a clamped-free beam by a piezoelectric actuator. *ESAIM Control Optim. Calc. Var.*, 12:545–563, 2006.
- [8] R. Curtain and H. Zwart. *An introduction to infinite-dimensional linear systems theory*. Springer-Verlag, 1995.
- [9] J.M. Gomes da Silva Jr and S. Tarbouriech. Antiwindup design with guaranteed regions of stability : an LMI-based approach. *IEEE Transactions on Automatic Control*, 50:106–111, 2005.
- [10] C.M. Dafermos and M. Slemrod. Asymptotic behavior of nonlinear contraction semigroups. *Journal of Functional Analysis*, 13(1):97–106, 1973.
- [11] B. d’Andréa Novel, F. Boustany, F. Conrad, and B.P. Rao. Feedback stabilization of a hybrid PDE-ODE system: Application to an overhead crane. *Mathematics of Control, Signals, and Systems*, 7(1):1–22, 1994.
- [12] T. Hu, A. R. Teel, and L. Zaccarian. Stability and performance for saturated systems via quadratic and nonquadratic Lyapunov functions. *IEEE Transactions on Automatic Control*, 51(11):1770–1786, 2006.
- [13] F.-L. Huang. Characteristic conditions for exponential stability of linear dynamical systems in Hilbert spaces. *Ann. Differential Equations*, 1(1):43–56, 1985.
- [14] H.K. Khalil. *Nonlinear Systems*. Prentice-Hall, 3rd edition, 2002.
- [15] G.C. King. *Vibrations and Waves*. Manchester Physics Series. Wiley, 2013.
- [16] G.R. Lindfield and J.E.T. Penny. *Numerical Methods: Using MATLAB*. Academic Press, 2012.
- [17] I. Miyadera. *Nonlinear Semigroups*. Translations of mathematical monographs. American Mathematical Society, 1992.
- [18] C. Prieur and F. Mazenc. ISS-Lyapunov functions for time-varying hyperbolic systems of balance laws. *Mathematics of Control, Signals, and Systems*, 24(1):111–134, 2012.
- [19] J. Prüss. On the spectrum of C_0 -semigroups. *Trans. Amer. Math. Soc.*, 284(2):847–857, 1984.
- [20] M. Slemrod. Feedback stabilization of a linear control system in Hilbert space with an a priori bounded control. *Mathematics of Control, Signals, and Systems*, 2(3):265–285, 1989.
- [21] S. Tarbouriech, G. Garcia J.-M. Gomes da Silva Jr, and I. Queinnec. *Stability and Stabilization of Linear Systems with Saturating Actuators*. Springer, 2011.
- [22] S. Tarbouriech, C. Prieur, and J.M. Gomes da Silva Jr. Stability analysis and stabilization of systems presenting nested saturations. *IEEE Transactions on Automatic Control*, 51(8):1364–1371, 2006.
- [23] L. Zaccarian and A.R. Teel. *Modern Anti-windup Synthesis: Control Augmentation for Actuator Saturation*. Princeton Series in Applied Mathematics. Princeton University Press, 2011.