



HAL
open science

Software-Based Burst Mode Reception Implementation for Time-domain Wavelength Interleaved Networks

Lida Sadeghioon, Paulette Gavignet, Vincent Alaiwan, Laurent Bramerie,
Esther Le Rouzic, Jean-Luc Barbey, Thierry Guillosoou, Eric Borgne,
Sébastien Lobo

► **To cite this version:**

Lida Sadeghioon, Paulette Gavignet, Vincent Alaiwan, Laurent Bramerie, Esther Le Rouzic, et al.. Software-Based Burst Mode Reception Implementation for Time-domain Wavelength Interleaved Networks. 41st European Conference on Optical Communication (ECOC 2015), Sep 2015, Valencia, Spain. 10.1109/ECOC.2015.7341872 . hal-01228746

HAL Id: hal-01228746

<https://hal.science/hal-01228746>

Submitted on 13 Nov 2015

HAL is a multi-disciplinary open access archive for the deposit and dissemination of scientific research documents, whether they are published or not. The documents may come from teaching and research institutions in France or abroad, or from public or private research centers.

L'archive ouverte pluridisciplinaire **HAL**, est destinée au dépôt et à la diffusion de documents scientifiques de niveau recherche, publiés ou non, émanant des établissements d'enseignement et de recherche français ou étrangers, des laboratoires publics ou privés.

Software-Based Burst Mode Reception Implementation for Time-domain Wavelength Interleaved Networks

Lida Sadeghioon^(1,2), Paulette Gavignet⁽¹⁾, Vincent Alaiwan⁽²⁾, Laurent Bramerie⁽²⁾, Esther Le Rouzic⁽¹⁾, Jean-Luc Barbey⁽¹⁾, Thierry Guillosoou⁽¹⁾, Eric Borgne⁽²⁾, Sébastien Lobo⁽²⁾

⁽¹⁾ Orange -Labs, 22307 Lannion, France, sadeghio@enssat.fr

⁽²⁾ FOTON Laboratory, CNRS, University of Rennes 1, ENSSAT, 22305 Lannion, France

Abstract *We demonstrate burst mode functionality on a continuous commercial receiver piloted by real-time control plane in an end-to-end sub-wavelength switching test-bed. The results show the receiver can maintain its continuous performance with marginal penalty regardless of data burst absence duration.*

Introduction

Switching sub-wavelength entities inside the big pipes channels appears as a promising solution for the operator that has to build a network with an efficient filling and different services.

Access to the sub-wavelength granularity directly at the optical layer is an alternative to electrical solution to reduce cost and power consumption by saving on electrical transit and electrical-to-optical and optical-to-electrical conversions. Amongst the various Sub-Lambda Photonic Switched Network (SLPSN) solutions, Time-domain Wavelength Interleaved Networking (TWIN) is an interesting solution since it provides optically transparent sub-wavelength grooming at intermediate/core nodes, while the intelligence and processing power remains at control plane and the edge nodes¹.

While synchronisation and scheduling are key functions of the TWIN control plane, fast tuneable laser (FTL) at source nodes and the burst mode receiver (BMRx) at the destination node are fundamental in TWIN data plane.

Due to the nature of the bursty traffic, variable durations of data absence at the receiver sides happen in a normal operation condition. This is a challenge for the BMRx functionality since low cut off frequency linked to capacitive coupling of electrical components at the receiver limits the data absence tolerance to a few hundreds of nano seconds.

Different BMRs have been proposed for Passive Optical Network applications which require quick response to incoming burst packets and high tolerance to the long Consecutive Identical Digit at the same time^{2,3}. However, these solutions do not address the optical burst absence in particular.

One approach to resolve this issue is to send the stuffing bursts/signal from the source side towards destinations that are not occupied to fill the data absence. This method can cause source blocking in mesh/tree based topologies.

In other proposed solutions, the stuffing signal is injected electronically at the receiver side in the data absence period. This method needs relatively complex electronics sampling tools at the receiver side⁴.

In previous work, we presented the implementation of the fundamental building blocks including synchronisation and scheduling in a real-time controlled plane at source side on TWIN based test-bed¹.

In this paper we experimentally demonstrate a software-based burst mode receiver with high tolerance to data burst absence in an end-to-end TWIN test-bed. Here we combine the key information in the control plane to drive a low cost optical local stuffing section and add the burst mode functionality to a continuous commercial receiver.

Real Time Orchestration

The core module of the control plane is the Central Control Entity (CCE). CCE takes the traffic matrix (considering, Service Level Agreements, and resiliency, etc. for the dimensioned network), the network topology and point-to-point propagation delays to calculate the scheduling (grant) files. Then it sends element control information (EC) including the grant file to all edge nodes, via a separate control channel. Each grant file contains:

- Source Information (SI): to which destination (on which wavelength) at what time data burst should be sent and for how long.
- Destination Information (DI): from which sources and for how long traffic comes; when the absence of traffic starts, and for how long it continues.

The CCE has global network knowledge and it is dynamically updated in case of changes (such as link updates, cuts, and traffic changes). Consequently SI's and "DI"s are periodically updated and sent to all the edge nodes in a defined control cycle, that varies according to the size of the network. The Real-Time (RT) engine role at CCE and all edge nodes is to

preserve the priority and switch on different cycles accurately.

The destination is notified about the duration of data absence thanks to DI message therefore at the receiver there is no need for a rapid per burst sampling to verify the beginning or presence of the signal for burst mode operation. Each node is prepared per control cycle for the local burst mode reception.

This control architecture prevents complicated calculations and lessens the need for computing algorithms and resources at each edge node. In the following we show how this architecture mitigates the hardware limitation and adds burst mode functionality to an off-the-shelf continuous receiver.

Experimental set-up

Fig. 1 shows the experimental setup for the above mentioned control plane at 40 MHz with a 9.95328 Gbps (STM64) data plane. The test bed consists of two source nodes: S1, S2 and two destination nodes: D3, D4 (the two destinations are identical; we present the results only for D3).

The Control Plane part is as follows: the CCE includes a computer to perform scheduling calculations. The RT engine on the National Instrument (NI) PXI 1082 chassis and NI PXIe 7962R modules with two Xilinx Virtex-5 SXT FPGAs are divided between CCE, and the source-destination nodes. The FPGA section in the CCE side has the master role. It takes the phase information of each node (coming from the signal generator at each node) via EC1 and EC2 and sends the relative starting time to all the nodes to initiate network level synchronisation.

Then at each node the grant files are received via control channel by RT engine and are passed to the FPGA section of each node. The critical role of RT engine is to keep the control message task timing and the grant files execution precisely.

FPGA section that is responsible for element

function per source and destination sides has to pilot the source (tuneable laser) and destination side (optical local stuffing) of each node according to SI and DI.

The description of the data plane is in the following: the source comprises an Anritsu MT 1810A Pulse Pattern Generator (PPG). It generates data bursts of 4.5 μ s data duration in PRBS $2^7 - 1$ with 205 ns preamble (2048 bits with 64 bits pattern in 32 bits in "1" and "0"), in addition to 38 ns of header (128 bits "1", 128 bits "0", 64 bits "1", 64 bits "0") in front of the burst and 19 ns (32 bits "0", 64 bits "1", 32 bits "0", 64 bits "1") as trailer. The guard time between the bursts is set to 300 ns at emission to compensate any clock inaccuracy and wavelength tuning time of the tuneable laser. As a result, at each 5.14 μ s, a burst can be sent according to grant files at each source. The PPG electrical signal is modulated (by MZM in OOK-NRZ format) on the optical signal generated by the Finisar S7500 Modulated Grating Y laser (MG-Y) tuneable laser with a rapid tuning time between different wavelengths (less than 100 ns).

The Core Nodes (CNs) contain two fixed demultiplexers and two optical passive couplers.

The burst mode receiver is composed of an optical coupler that allows combining data signal coming from source side and local stuffing laser into the Finisar XFP EVAL board with the XFP module FTLX1812M3BCL.

Our proposed mechanism is the following: in absence of data burst at the receiver side, the control plane drives the optical stuffing laser which is in our case a continuous laser externally modulated by clock signal at 1 GHz.

Experimental Results

We first evaluate the data absence tolerance of the XFP receiver (without the proposed mechanism). Fig. 2 shows the BER performance of the receiver for PRBS $2^7 - 1$ and $2^{15} - 1$ signals in continuous mode as references, and data

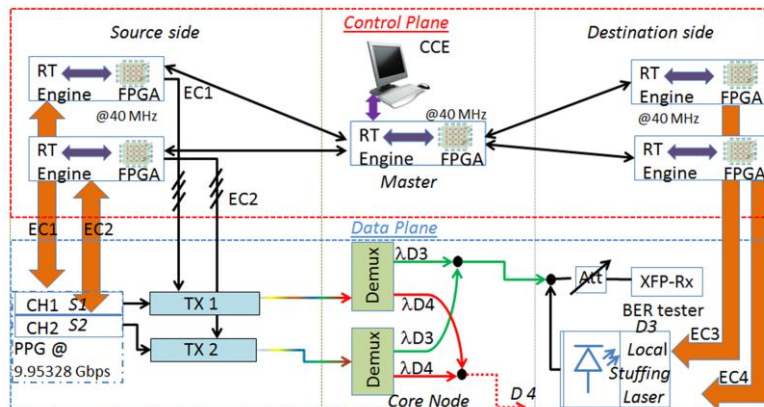

Fig. 1: Experimental set-up

burst signal with data absence (for simplicity we call the data absence gap) from 300 ns up to 1 μ s. The performance for the bursts with 300 ns gap is identical to the PRBS $2^{15}-1$ due to the mixture of long sequence of “1”s and “0”s as preamble, header and trailer with 2^7-1 PRBS as the burst body. Thus this receiver performs with no penalty for bursts generated with 300 ns guard time. As we increase the gap up to 500 ns the penalty increases up to 1.2 dB. Fig. 2 shows that a gap larger than 500 ns is not well tolerated by the receiver, and error floors appear. The effect of low cut-off frequency (several tens KHz) of the receiver deteriorates the quality of the received bursts to an unrecoverable limit for 1 μ s gap.

Next, we implement our proposal of software based burst mode reception by providing SI and DI files to both sources and destinations. SI files indicate to S1, S2 when to transmit traffic towards D3 (@1558.17nm), D4 (@1556.56 nm), and DI triggers the local stuffing laser to fill the absence of data burst.

Fig. 3 shows oscilloscope traces of the signal (bursts combined with local stuffing) at the output of optical coupler that enters the XFP Rx (pink traces). Fig. 3 (a) and (b) subsequently show the signal with one and two data burst absence that are filled by local stuffing laser, at the receiver side. We can see the local stuffing signal is positioned exactly according to the DI file with the defined 300 ns guard time.

To perform the BER measurement, we generate a mask signal (blue traces in Fig.3) to separate the burst data from the stuffing at the BER test-set. In Fig. 3 the 100 ns/div and 50 ns/div zoom scales illustrate the position of the mask signals right after the burst preamble where the header information starts.

Results show no penalty for 5.14 μ s stuffing (data absence). Then we increase the data absence to 10.28 μ s (corresponding to 2 stuffing signals). We obtain only a maximum of 0.5 dB penalty comparing to the reference (burst with 300 ns gap). This is due to slight variation of mean received power measurement in presence of optical stuffing burst.

Conclusions

We demonstrate a software-based burst mode reception implementing an end-to-end bit rate transparent control plane on a TWIN test-bed.

A penalty of 0.5 dB has been achieved for two bursts absence proving that a simple commercial XFP receiver used in continuous mode can cope with burst arrival rhythm with long absence, alleviating the constraints of low cut-off frequency of components.

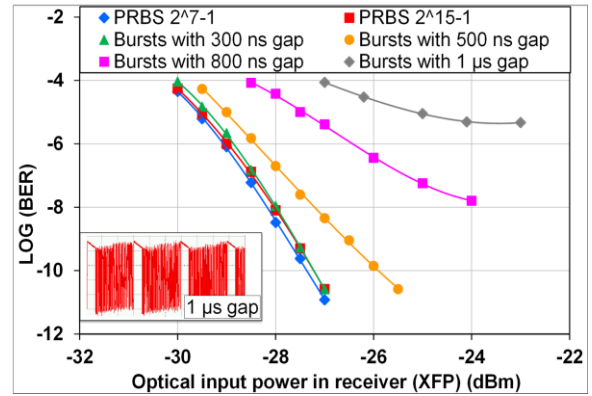

Fig. 2: BER versus average optical input power at RX.

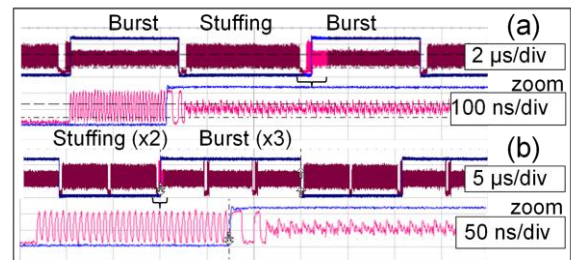

Fig. 3: (a) and (b) One and two data burst absence combined with local stuffing. The mask signal (blue trace) shows the position of the mask versus the burst.

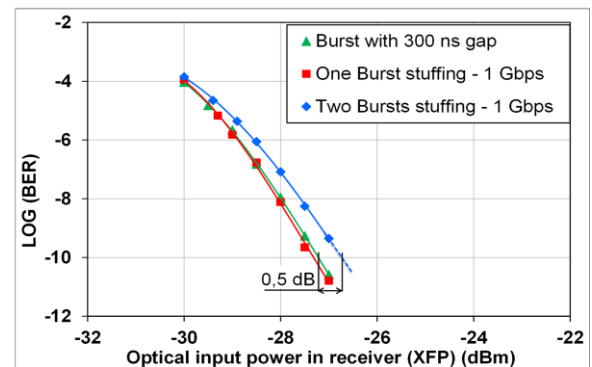

Fig. 4: BER versus average optical input power in Rx.

Acknowledgements

This work was partly funded by the DGCIS in the frame of the CELTIC-Plus project SASER-SaveNet.

References

- [1] L. Sadeghioon et al., “First Experimental Demonstration of Real-Time Orchestration in a Multi-Head Metro Network”, Proc. ICTON, Th.A1.6. Graz, 2014.
- [2] X. Z. Qiu. “Burst-mode receiver technology for short synchronization”, OFC Tutorial OW3G.4, 2013.
- [3] J. E. Simsarian et al., “Fast-Tuning 224-Gb/s Intradyne Receiver for Optical Packet Networks”, Proc. OFC, PDPB5, 2010.
- [4] L.A Neto et al., “10 Gb/s Continuous Clock and Data Recovery for Burst Mode Transmissions with Externally Modulated Laser”, Proc. ANIC, JWA2, 2010.