



**HAL**  
open science

# Networked Control Systems in the Presence of Scheduling Protocols and Communication Delays

Kun Liu, Emilia Fridman, Laurentiu Hetel

► **To cite this version:**

Kun Liu, Emilia Fridman, Laurentiu Hetel. Networked Control Systems in the Presence of Scheduling Protocols and Communication Delays. *SIAM Journal on Control and Optimization*, 2015, 53 (4), pp.1768-1788. 10.1137/140980570 . hal-01228373

**HAL Id: hal-01228373**

**<https://hal.science/hal-01228373v1>**

Submitted on 18 Nov 2024

**HAL** is a multi-disciplinary open access archive for the deposit and dissemination of scientific research documents, whether they are published or not. The documents may come from teaching and research institutions in France or abroad, or from public or private research centers.

L'archive ouverte pluridisciplinaire **HAL**, est destinée au dépôt et à la diffusion de documents scientifiques de niveau recherche, publiés ou non, émanant des établissements d'enseignement et de recherche français ou étrangers, des laboratoires publics ou privés.

# Networked control systems in the presence of scheduling protocols and communication delays \*

Kun Liu † Emilia Fridman‡ Laurentiu Hetel§

August 14, 2018

## Abstract

This paper develops the time-delay approach to Networked Control Systems (NCSs) in the presence of variable transmission delays, sampling intervals and communication constraints. The system sensor nodes are supposed to be distributed over a network. Due to communication constraints only one node output is transmitted through the communication channel at once. The scheduling of sensor information towards the controller is ruled by a weighted Try-Once-Discard (TOD) or by Round-Robin (RR) protocols. Differently from the existing results on NCSs in the presence of scheduling protocols (in the frameworks of hybrid and discrete-time systems), we allow the communication delays to be greater than the sampling intervals. A novel hybrid system model for the closed-loop system is presented that contains *time-varying delays in the continuous dynamics and in the reset conditions*. A new Lyapunov-Krasovskii method, which is based on discontinuous in time Lyapunov functionals is introduced for the stability analysis of the delayed hybrid systems. Polytopic type uncertainties in the system model can be easily included in the analysis. The efficiency of the time-delay approach is illustrated on the examples of uncertain cart-pendulum and of batch reactor.

**Key words** networked control systems, time-delay approach, scheduling protocols, hybrid systems, Lyapunov-Krasovskii method.

**AMS subject classification.** 93D15, 93D05.

## 1 Introduction

Networked Control Systems (NCSs) are systems with spatially distributed sensors, actuators and controller nodes which exchange data over a communication

---

\*This work was partially supported by Israel Science Foundation (grant No 754/10), the Knut and Alice Wallenberg Foundation and the Swedish Research Council.

†ACCESS Linnaeus Centre and School of Electrical Engineering, KTH Royal Institute of Technology, SE-100 44 Stockholm, Sweden, kunliu@kth.se

‡School of Electrical Engineering, Tel Aviv University, Tel Aviv, 69978 Israel, emilia@eng.tau.ac.il

§University Lille Nord de France, LAGIS, FRE CNRS 3303, Ecole Centrale de Lille, Cite Scientifique, BP 48, 59651 Villeneuve d'Ascq cedex, France, laurentiu.hetel@ec-lille.fr

data channel [1]. In many NCSs, only one node is allowed to use the communication channel at once. The communication along the data channel is orchestrated by a scheduling rule called protocol. The introduction of communication network media offers several practical advantages: reduced costs, ease of installation and maintenance and increased flexibility.

Three main approaches have been used to model the sampled-data control and later to the NCSs: a discrete-time [6, 10], an impulsive/hybrid system [18, 20] and a time-delay [7, 9, 11, 12] approaches. The hybrid system approach, which was inspired by [23], has been applied to nonlinear NCSs under Try-Once-Discard (TOD) and Round-Robin (RR) protocols in [15, 20]. In the framework of discrete-time approach, network-based stabilization of linear time-invariant systems with TOD/RR protocols and communication delays has been considered in [6]. Variable sampling intervals and/or *small communication delays* (that are *smaller than the sampling intervals*) have been considered in the above works.

Note that in the absence of scheduling protocols, all the three approaches are applicable to non-small communication delays (see e.g., [3, 19]). The time-delay approach that was recently suggested in [16] allowed, for the first time, to treat NCSs under RR protocol in the presence of non-small communication delays. In [16] the closed-loop system was presented as a switched system with multiple ordered delays.

In the present paper, we consider linear (probably, uncertain) NCS with additive essentially bounded disturbances in the presence of scheduling protocols, variable sampling intervals and transmission delays. Our first goal is to extend the time-delay approach to NCSs under TOD protocol in the presence of communication delays that are allowed to be non-small. This leads to a novel hybrid system model for the closed-loop system, where *time-varying delays appear in the dynamics and in the reset equations*. Since a similar hybrid system model corresponds to RR protocol, we derive new conditions for Input-To-State (ISS) under RR protocol as well. These conditions are computationally simpler than the existing ones of [16] though may lead to more conservative results. A novel Lyapunov-Krasovskii method is introduced for hybrid delayed systems, which is based on discontinuous in time Lyapunov functionals.

Polytopic type uncertainties in the system model can be easily included in the analysis. The efficiency and advantages of the presented approach are illustrated by two examples. Some preliminary results were presented in [17].

**Notation:** Throughout the paper, the superscript ‘ $T$ ’ stands for matrix transposition,  $\mathbb{R}^n$  denotes the  $n$  dimensional Euclidean space with vector norm  $|\cdot|$ ,  $\mathbb{R}^{n \times m}$  is the set of all  $n \times m$  real matrices, and the notation  $P > 0$ , for  $P \in \mathbb{R}^{n \times n}$  means that  $P$  is symmetric and positive definite. The symmetric elements of the symmetric matrix will be denoted by  $*$ ,  $\lambda_{min}(P)$  denotes the smallest eigenvalue of matrix  $P$ . The space of functions  $\phi : [-\tau_M, 0] \rightarrow \mathbb{R}^n$ , which are absolutely continuous on  $[-\tau_M, 0]$ , and have square integrable first order derivatives is denoted by  $W[-\tau_M, 0]$  with the norm  $\|\phi\|_W = \max_{\theta \in [-\tau_M, 0]} |\phi(\theta)| + \left[ \int_{-\tau_M}^0 |\dot{\phi}(s)|^2 ds \right]^{\frac{1}{2}}$ .  $\mathbb{Z}_+$  denotes the set  $\{0, 1, 2, \dots\}$ , whereas  $\mathbb{N}$  denotes the natural numbers. The symbol  $x_t$  denotes  $x_t(\theta) = x(t+\theta)$ ,  $\theta \in [-\tau_M, 0]$ , whereas

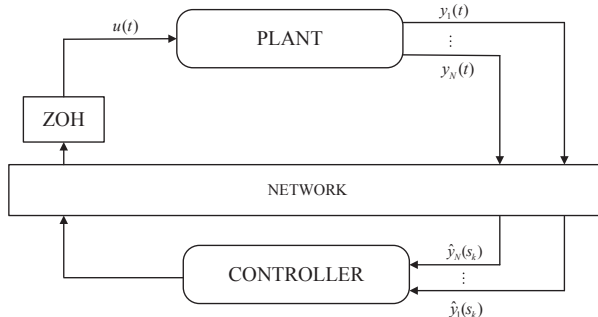

Figure 1: System architecture with  $N$  sensors

$\|w[t_0, t]\|_\infty$  stands for the essential supremum of the Euclidean norm  $|w[t_0, t]|$ , where  $w : [t_0, t] \rightarrow \mathbb{R}^{n_w}$ . MATI and MAD denote Maximum Allowable Transmission Interval and Maximum Allowable Delay, respectively.

## 2 Problem formulation

### 2.1 The description of NCS and the hybrid model

Consider the system architecture in Figure 1 with plant

$$(1) \quad \dot{x}(t) = Ax(t) + Bu(t) + D\omega(t), \quad t \geq 0,$$

where  $x(t) \in \mathbb{R}^n$  is the state vector,  $u(t) \in \mathbb{R}^m$  is the control input,  $\omega(t) \in \mathbb{R}^q$  is the essentially bounded disturbance. Assume that there exists a real number  $\Delta > 0$  such that  $\|\omega[0, t]\|_\infty \leq \Delta$  for all  $t \geq 0$ . The system matrices  $A$ ,  $B$  and  $D$  can be uncertain with polytopic type uncertainties.

The system has several nodes ( $N$  distributed sensors, a controller node and an actuator node) which are connected via the network. The measurements are given by  $y_i(t) = C_i x(t) \in \mathbb{R}^{n_i}$ ,  $i = 1, \dots, N$ ,  $\sum_{i=1}^N n_i = n_y$  and we denote  $C = [C_1^T \ \dots \ C_N^T]^T$ ,  $y(t) = [y_1^T(t) \ \dots \ y_N^T(t)]^T \in \mathbb{R}^{n_y}$ . Let  $s_k$  denote the unbounded monotonously increasing sequence of sampling instants

$$0 = s_0 < s_1 < \dots < s_k < \dots, \quad k \in \mathbb{Z}_+, \quad \lim_{k \rightarrow \infty} s_k = \infty.$$

At each sampling instant  $s_k$ , one of the outputs  $y_i(s_k) \in \mathbb{R}^{n_i}$  is transmitted via the sensor network. We suppose that data loss is not possible and that the transmission of the information over the network is subject to a variable delay  $\eta_k$ . Then  $t_k = s_k + \eta_k$  is the updating time instant of the Zero-Order Hold (ZOH).

Differently from [6, 15], we do not restrict the network delays to be small with  $t_k = s_k + \eta_k < s_{k+1}$ , i.e.  $\eta_k < s_{k+1} - s_k$ . As in [19] we allow the delay

to be non-small provided that the old sample cannot get to the destination (to the controller or to the actuator) after the most recent one. Assume that the network-induced delay  $\eta_k$  and the time span between the updating and the most recent sampling instants are bounded:

$$(2) \quad t_{k+1} - t_k + \eta_k \leq \tau_M, \quad 0 \leq \eta_m \leq \eta_k \leq \text{MAD}, \quad k \in \mathbb{Z}_+,$$

where  $\tau_M$  denotes the maximum time span between the time

$$(3) \quad s_k = t_k - \eta_k$$

at which the state is sampled and the time  $t_{k+1}$  at which the next update arrives at the destination. Here  $\eta_m$  and MAD are known bounds and  $\tau_M = \text{MATI} + \text{MAD}$ . Since  $\text{MATI} = \tau_M - \text{MAD} \leq \tau_M - \eta_m$ ,  $\eta_m > \frac{\tau_M}{2}$  implies that the network delays are non-small due to  $\eta_k \geq \eta_m > \tau_M - \eta_m$ . In the examples of Section 6, we will show that our method is applicable for  $\eta_m > \frac{\tau_M}{2}$ .

Denote by  $\hat{y}(s_k) = [\hat{y}_1^T(s_k) \ \cdots \ \hat{y}_N^T(s_k)]^T \in \mathbb{R}^{n_y}$  the output information submitted to the scheduling protocol. At each sampling instant  $s_k$ , one of the system nodes  $i \in \{1, \dots, N\}$  is active, that is only one of  $\hat{y}_i(s_k)$  values is updated with the recent output  $y_i(s_k)$ . Let  $i_k^* \in \{1, \dots, N\}$  denote the active output node at the sampling instant  $s_k$ , which will be chosen due to scheduling protocols.

Consider the error between the system output  $y(s_k)$  and the last available information  $\hat{y}(s_{k-1})$ :

$$(4) \quad \begin{aligned} e(t) &= \text{col}\{e_1(t), \dots, e_N(t)\} \equiv \hat{y}(s_{k-1}) - y(s_k), \\ t &\in [t_k, t_{k+1}), \quad k \in \mathbb{Z}_+, \quad \hat{y}(s_{-1}) \triangleq 0, \quad e(t) \in \mathbb{R}^{n_y}. \end{aligned}$$

We suppose that the controller and the actuator are event-driven (in the sense that the controller and the ZOH update their outputs as soon as they receive a new sample). The most recent output information at the controller level is denoted by  $\hat{y}(s_k)$ .

### Static output feedback control

Assume that there exists a matrix  $K = [K_1 \ \cdots \ K_N]$ ,  $K_i \in \mathbb{R}^{m \times n_i}$  such that  $A + BKC$  is Hurwitz. Then, the static output feedback controller has a form

$$(5) \quad u(t) = K_{i_k^*} y_{i_k^*}(t_k - \eta_k) + \sum_{i=1, i \neq i_k^*}^N K_i \hat{y}_i(t_{k-1} - \eta_{k-1}), \quad t \in [t_k, t_{k+1}),$$

where  $i_k^*$  is the index of the active node at  $s_k$  and  $\eta_k$  is communication delay. We obtain thus the impulsive closed-loop model with the following continuous dynamics:

$$(6) \quad \begin{aligned} \dot{x}(t) &= Ax(t) + A_1 x(t_k - \eta_k) + \sum_{i=1, i \neq i_k^*}^N B_i e_i(t) + D\omega(t), \\ \dot{e}(t) &= 0, \quad t \in [t_k, t_{k+1}), \end{aligned}$$

where  $A_1 = BKC$ ,  $B_i = BK_i$ ,  $i = 1, \dots, N$ .

Taking into account (4), we obtain

$$\begin{aligned} e_i(t_{k+1}) &= \hat{y}_i(s_k) - y_i(s_{k+1}) = y_i(s_k) - y_i(s_{k+1}) \\ &= C_i x(s_k) - C_i x(s_{k+1}), \quad i = i_k^*, \end{aligned}$$

and

$$\begin{aligned} e_i(t_{k+1}) &= \hat{y}_i(s_k) - y_i(s_{k+1}) = \hat{y}_i(s_{k-1}) - y_i(s_{k+1}) \\ &= \hat{y}_i(s_{k-1}) - y_i(s_k) + y_i(s_k) - y_i(s_{k+1}) \\ &= e_i(t_k) + C_i[x(s_k) - x(s_{k+1})], \quad i \neq i_k^*, i \in \mathbb{N}. \end{aligned}$$

Thus, the delayed reset system is given by

$$(7) \quad \begin{aligned} x(t_{k+1}) &= x(t_{k+1}^-), \\ e_i(t_{k+1}) &= C_i[x(t_k - \eta_k) - x(t_{k+1} - \eta_{k+1})], \quad i = i_k^*, \\ e_i(t_{k+1}) &= e_i(t_k) + C_i[x(t_k - \eta_k) - x(t_{k+1} - \eta_{k+1})], \quad i \neq i_k^*, i \in \mathbb{N}. \end{aligned}$$

Therefore, (6)-(7) is the hybrid model of the NCS. Since  $x(t_k - \eta_k) = x(t - \tau(t))$  for  $t \in [t_k, t_{k+1})$  with  $\tau(t) = t - t_k + \eta_k \in [\eta_m, \tau_M]$  (cf. (2)), the hybrid system model (6)-(7) contains the piecewise-continuous delay  $\tau(t)$  in the continuous-time dynamics (6). Even for  $\eta_k = 0$  we have the delayed state  $x(t_k) = x(t - \tau(t))$  with  $\tau(t) = t - t_k$ .

Note that the first updating time  $t_0$  corresponds to the time instant when the first data is received by the actuator. Assume that initial conditions for (6)-(7) are given by  $x_{t_0} \in W[-\tau_M, 0]$  and  $e(t_0) = -Cx(t_0 - \eta_0) = -Cx_0$ .

### Dynamic output feedback control

Assuming that the controller is directly connected to the actuator, consider a dynamic output feedback controller of the form

$$\begin{aligned} \dot{x}_c(t) &= A_c x_c(t) + B_c \hat{y}(s_k), \\ u(t) &= C_c x_c(t) + D_c \hat{y}(s_k), \quad t \in [t_k, t_{k+1}), \quad k \in \mathbb{Z}_+, \end{aligned}$$

where  $x_c(t) \in \mathbb{R}^{n_c}$ ,  $A_c, B_c, C_c$  and  $D_c$  are the matrices with appropriate dimensions. Let  $e_i(t) (i = 1, \dots, N)$  be defined by (4). The closed-loop system can be presented in the form of (6)-(7), where  $x$ ,  $e_i$  and the matrices are changed by the ones with the bars as follows:

$$\begin{aligned} \bar{x} &= \begin{bmatrix} x \\ x_c \end{bmatrix}, \quad \bar{A} = \begin{bmatrix} A & BC_c \\ 0_{n_c \times n} & A_c \end{bmatrix}, \quad \bar{B}_i = \begin{bmatrix} BD_c \\ B_c \end{bmatrix}, \quad \bar{D} = \begin{bmatrix} D \\ 0_{n_c \times q} \end{bmatrix}, \\ \bar{A}_1 &= \begin{bmatrix} BD_c C & 0_{n \times n_c} \\ B_c C & 0_{n_c \times n_c} \end{bmatrix}, \quad \bar{C}_1 = \begin{bmatrix} C_1 & 0 \\ 0 & 0 \end{bmatrix}, \quad \bar{C}_i \in \mathbb{R}^{n_y \times (n+n_c)}, \\ \bar{C}_2 &= \begin{bmatrix} 0_{n \times n_1} & C_2^T & 0 \\ 0_{n_c \times n_1} & 0 & 0 \end{bmatrix}^T, \dots, \quad \bar{C}_N = \begin{bmatrix} 0 & C_N^T \\ 0 & 0 \end{bmatrix}^T, \\ \bar{e}_1(t) &= [e_1^T(t) \ 0]^T, \quad \bar{e}_2(t) = [0_{1 \times n_1} \ e_2^T(t) \ 0]^T, \dots \quad \bar{e}_N(t) = [0 \ e_N^T(t)]^T, \quad \bar{e}_i(t) \in \mathbb{R}^{n_y}. \end{aligned}$$

**Remark 2.1** In [15], a piecewise-continuous error  $e(t) = \hat{y}(t_k) - y(t)$ ,  $t \in [s_k, s_{k+1}]$  is defined, which leads to the non-delayed continuous dynamics. The

derivation of reset equations is based on the assumption of small communication delays, that is avoided in our approach. In our approach  $e(t)$  is different: it is given by (4) and is piecewise-constant. As a result, our hybrid model is different with the delayed continuous dynamics. Moreover, in the absence of scheduling protocols, the closed-loop system is given by non-hybrid system (6), where  $e(t) \equiv 0$ . The latter is consistent with the time-delay model considered e.g. in [11, 12].

## 2.2 Scheduling protocols

### TOD protocol

In TOD protocol, the output node  $i \in \{1, \dots, N\}$  with the greatest (weighted) error will be granted the access to the network.

**Definition 2.2 (Weighted TOD protocol)** Let  $Q_i > 0 (i = 1, \dots, N)$  be some weighting matrices. At the sampling instant  $s_k$ , the weighted TOD protocol is a protocol for which the active output node with the index  $i_k^*$  is defined as any index that satisfies

$$(8) \quad |\sqrt{Q_{i_k^*}} e_{i_k^*}(t)|^2 \geq |\sqrt{Q_i} e_i(t)|^2, \quad t \in [t_k, t_{k+1}), \quad k \in \mathbb{Z}_+, \quad i = 1, \dots, N.$$

A possible choice of  $i_k^*$  is given by

$$i_k^* = \min\{\arg \max_{i \in \{1, \dots, N\}} |\sqrt{Q_i} (\hat{y}_i(s_{k-1}) - y_i(s_k))|^2\}.$$

The conditions for computing the weighting matrices  $Q_1, \dots, Q_N$  will be given in Theorem 3.2 below.

**Remark 2.3** For implementation of TOD protocol in wireless networks we refer to [4].

### RR protocol

The active output node is chosen periodically:

$$(9) \quad \begin{aligned} i_k^* &= i_{k+N}^*, \text{ for all } k \in \mathbb{Z}_+, \\ i_j^* &\neq i_l^*, \text{ for } 0 \leq j < l \leq N-1. \end{aligned}$$

**Remark 2.4** Note that another model for the closed-loop system under RR protocol was given in [16]. The model in [16] is a switched system with ordered delays  $\tau_1(t) < \dots < \tau_N(t)$ , where  $\tau_i(t) = t - t_{k-i+1} + \eta_{k-i+1}$ ,  $i = 1, \dots, N$ . A Lyapunov-Krasovskii analysis of the latter model is based on the standard time-independent Lyapunov functional for interval delay.

**Definition 2.5** *The hybrid system (6)-(7) with essentially bounded disturbance  $\omega$  is said to be partially ISS with respect to  $x$  (or  $x$ -ISS) if there exist constants  $b > 0, \delta > 0$  and  $c > 0$  such that the following holds for  $t \geq t_0$*

$$|x(t)|^2 \leq be^{-\delta(t-t_0)} [\|x_{t_0}\|_W^2 + |e(t_0)|^2] + c\|\omega[t_0, t]\|_\infty^2$$

for the solutions of the hybrid system initialized with  $x_{t_0} = \phi \in W[-\tau_M, 0]$  and  $e(t_0) \in \mathbb{R}^{n_y}$ . The hybrid system (6)-(7) is ISS if additionally the following bound is valid for  $t \geq t_0$

$$|e(t)|^2 \leq be^{-\delta(t-t_0)} [\|x_{t_0}\|_W^2 + |e(t_0)|^2] + c\|\omega[t_0, t]\|_\infty^2.$$

Our objective is to derive Linear Matrix Inequality (LMI) conditions for the partial ISS of the hybrid system (6)-(7) with respect to the variable of interest  $x$ . In [5], the notion of partial stability was also used. In Section 3 below, ISS of (6)-(7) under TOD protocol with  $N$  sensor nodes will be studied. For  $N = 2$ , less restrictive conditions will be derived in Section 4, and it will be shown that the same conditions guarantee  $x$ -ISS of (6)-(7) under RR protocol. In Section 5, the latter conditions will be extended to RR protocol with  $N \geq 2$ .

### 3 ISS under TOD protocol: general $N$

Note that the differential equation for  $x$  given by (6) depends on  $e_i(t) = e_i(t_k)$ ,  $t \in [t_k, t_{k+1})$  with  $i \neq i_k^*$  only. Consider the following Lyapunov functional:

$$\begin{aligned} V_e(t) &= V(t, x_t, \dot{x}_t) + \sum_{i=1}^N e_i^T(t) Q_i e_i(t), \\ V(t, x_t, \dot{x}_t) &= \tilde{V}(t, x_t, \dot{x}_t) + V_G, \\ V_G &= \sum_{i=1}^N (\tau_M - \eta_m) \int_{s_k}^t e^{2\alpha(s-t)} |\sqrt{G_i} C_i \dot{x}(s)|^2 ds, \\ \tilde{V}(t, x_t, \dot{x}_t) &= x^T(t) P x(t) + \int_{t-\eta_m}^t e^{2\alpha(s-t)} x^T(s) S_0 x(s) ds \\ &\quad + \int_{t-\tau_M}^{t-\eta_m} e^{2\alpha(s-t)} x^T(s) S_1 x(s) ds \\ &\quad + \eta_m \int_{-\eta_m}^0 \int_{t+\theta}^t e^{2\alpha(s-t)} \dot{x}^T(s) R_0 \dot{x}(s) ds d\theta \\ &\quad + (\tau_M - \eta_m) \int_{-\tau_M}^{-\eta_m} \int_{t+\theta}^t e^{2\alpha(s-t)} \dot{x}^T(s) R_1 \dot{x}(s) ds d\theta, \\ P &> 0, S_j > 0, R_j > 0, G_i > 0, Q_i > 0, \alpha > 0, \\ j &= 0, 1, i = 1, \dots, N, t \in [t_k, t_{k+1}), k \in \mathbb{Z}_+, \end{aligned} \tag{10}$$

where  $x_t(\theta) \triangleq x(t + \theta)$ ,  $\theta \in [-\tau_M, 0]$  and where we define (for simplicity)  $x(t) = x_0$ ,  $t < 0$ .

Here the terms

$$e_i^T(t) Q_i e_i(t) \equiv e_i^T(t_k) Q_i e_i(t_k), \quad t \in [t_k, t_{k+1})$$

are piecewise-constant,  $\tilde{V}(t, x_t, \dot{x}_t)$  presents the standard Lyapunov functional for systems with interval delays  $\tau(t) \in [\eta_m, \tau_M]$ . *The novel piecewise-continuous*



in time term  $V_G$  is inserted to cope with the delays in the reset conditions. It is continuous on  $[t_k, t_{k+1})$  and do not grow in the jumps (when  $t = t_{k+1}$ ), since

$$\begin{aligned}
(11) \quad & V_G|_{t=t_{k+1}} - V_G|_{t=t_{k+1}^-} \\
&= \sum_{i=1}^N (\tau_M - \eta_m) \int_{s_{k+1}}^{t_{k+1}} e^{2\alpha(s-t_{k+1})} |\sqrt{G_i} C_i \dot{x}(s)|^2 ds \\
&\quad - \sum_{i=1}^N (\tau_M - \eta_m) \int_{s_k}^{t_{k+1}^-} e^{2\alpha(s-t_{k+1})} |\sqrt{G_i} C_i \dot{x}(s)|^2 ds \\
&\leq - \sum_{i=1}^N (\tau_M - \eta_m) e^{-2\alpha\tau_M} \int_{s_k}^{s_{k+1}} |\sqrt{G_i} C_i \dot{x}(s)|^2 ds \\
&\leq - \sum_{i=1}^N e^{-2\alpha\tau_M} |\sqrt{G_i} C_i [x(s_k) - x(s_{k+1})]|^2,
\end{aligned}$$

where we applied Jensen's inequality (see e.g., [14]). The function  $V_e(t)$  is thus continuous and differentiable over  $[t_k, t_{k+1})$ . The following lemma gives sufficient conditions for the  $x$ -ISS of (6)-(8):

**Lemma 3.1** *Let there exist positive constants  $\alpha, b, 0 < Q_i \in \mathbb{R}^{n_i \times n_i}, 0 < U_i \in \mathbb{R}^{n_i \times n_i}, 0 < G_i \in \mathbb{R}^{n_i \times n_i}, i = 1, \dots, N$ , and  $V_e(t)$  of (10) such that along (6) the following inequality holds*

$$(12) \quad \dot{V}_e(t) + 2\alpha V_e(t) - \frac{1}{\tau_M - \eta_m} \sum_{i=1, i \neq i_k^*}^N |\sqrt{U_i} e_i(t)|^2 - 2\alpha |\sqrt{Q_{i_k^*}} e_{i_k^*}(t)|^2 - b|\omega(t)|^2 \leq 0, \quad t \in [t_k, t_{k+1}).$$

Assume additionally that

$$(13) \quad \Omega_i \triangleq \begin{bmatrix} -\frac{1-2\alpha(\tau_M-\eta_m)}{N-1} Q_i + U_i & Q_i \\ * & Q_i - G_i e^{-2\alpha\tau_M} \end{bmatrix} < 0, \quad i = 1, \dots, N.$$

Then  $V_e(t)$  does not grow in the jumps along (6)-(8):

$$(14) \quad \Theta \triangleq V_e(t_{k+1}) - V_e(t_{k+1}^-) + \sum_{i=1, i \neq i_k^*}^N |\sqrt{U_i} e_i(t_k)|^2 + 2\alpha(\tau_M - \eta_m) |\sqrt{Q_{i_k^*}} e_{i_k^*}(t_k)|^2 \leq 0.$$

Moreover, the following bounds hold for a solution of (6)-(8) initialized by  $x_{t_0} \in W[-\tau_M, 0], e(t_0) \in \mathbb{R}^{n_y}$ :

$$(15) \quad \begin{aligned} V(t, x_t, \dot{x}_t) &\leq e^{-2\alpha(t-t_0)} V_e(t_0) + \frac{b}{2\alpha} \Delta^2, \quad t \geq t_0, \\ V_e(t_0) &= V(t_0, x_{t_0}, \dot{x}_{t_0}) + \sum_{i=1}^N |\sqrt{Q_i} e_i(t_0)|^2, \end{aligned}$$

and

$$(16) \quad \sum_{i=1}^N |\sqrt{Q_i} e_i(t)|^2 \leq \tilde{c} e^{-2\alpha(t-t_0)} V_e(t_0) + \frac{b}{2\alpha} \Delta^2,$$

where  $\tilde{c} = e^{2\alpha(\tau_M - \eta_m)}$ , implying ISS of (6)-(8).

**Proof.** Since  $\int_{t_k}^t e^{-2\alpha(t-s)} ds \leq \tau_M - \eta_m, t \in [t_k, t_{k+1})$  and  $|\omega(t)| \leq \Delta$ , by the comparison principle, (12) implies

$$(17) \quad \begin{aligned} V_e(t) &\leq e^{-2\alpha(t-t_k)} V_e(t_k) + \sum_{i=1, i \neq i_k^*}^N \{ |\sqrt{U_i} e_i(t_k)|^2 \} \\ &\quad + 2\alpha(\tau_M - \eta_m) |\sqrt{Q_{i_k^*}} e_{i_k^*}(t_k)|^2 + b\Delta^2 \int_{t_k}^t e^{-2\alpha(t-s)} ds, \quad t \in [t_k, t_{k+1}). \end{aligned}$$

Note that (13) yields  $0 < 2\alpha(\tau_M - \eta_m) < 1$  and  $U_i \leq \frac{1-2\alpha(\tau_M - \eta_m)}{N-1} Q_i \leq Q_i$ ,  $i = 1, \dots, N$ . Hence,

$$(18) \quad V(t, x_t, \dot{x}_t) \leq e^{-2\alpha(t-t_k)} V_e(t_k) + b\Delta^2 \int_{t_k}^t e^{-2\alpha(t-s)} ds, \quad t \in [t_k, t_{k+1}).$$

Since  $\tilde{V}|_{t=t_{k+1}} = \tilde{V}|_{t=t_{k+1}^-}$  and  $e(t_{k+1}^-) = e(t_k)$ , we obtain

$$\Theta = \sum_{i=1}^N [|\sqrt{Q_i} e_i(t_{k+1})|^2 - |\sqrt{Q_i} e_i(t_k)|^2] + \sum_{i=1, i \neq i_k^*}^N |\sqrt{U_i} e_i(t_k)|^2 + 2\alpha(\tau_M - \eta_m) \sqrt{Q_{i_k^*}} e_{i_k^*}(t_k)|^2 + V_G|_{t=t_{k+1}} - V_G|_{t=t_{k+1}^-}.$$

Then taking into account (11) we find

$$\Theta \leq |\sqrt{Q_{i_k^*}} e_{i_k^*}(t_{k+1})|^2 + \sum_{i=1, i \neq i_k^*}^N |\sqrt{Q_i} e_i(t_{k+1})|^2 - [1 - 2\alpha(\tau_M - \eta_m)] |\sqrt{Q_{i_k^*}} e_{i_k^*}(t_k)|^2 - \sum_{i=1, i \neq i_k^*}^N \{e_i^T(t_k) [Q_i - U_i] e_i(t_k)\} - \sum_{i=1}^N e^{-2\alpha\tau_M} |\sqrt{G_i} C_i [x(s_k) - x(s_{k+1})]|^2.$$

Note that under TOD protocol

$$-|\sqrt{Q_{i_k^*}} e_{i_k^*}(t_k)|^2 \leq -\frac{1}{N-1} \sum_{i=1, i \neq i_k^*}^N |\sqrt{Q_i} e_i(t_k)|^2.$$

Denote  $\zeta_i = \text{col}\{e_i(t_k), C_i[x(s_k) - x(s_{k+1})]\}$ . Then, employing (7) and (3) we arrive at

$$\Theta \leq -|\sqrt{G_{i_k^*}} e^{-2\alpha\tau_M} - Q_{i_k^*} C_{i_k^*} [x(s_k) - x(s_{k+1})]|^2 + \sum_{i=1, i \neq i_k^*}^N \zeta_i^T \Omega_i \zeta_i \leq 0,$$

that yields (14).

The inequalities (14) and (17) with  $t = t_{k+1}^-$  imply

$$V_e(t_{k+1}) \leq e^{-2\alpha(t_{k+1}-t_k)} V_e(t_k) + b\Delta^2 \int_{t_k}^{t_{k+1}} e^{-2\alpha(t_{k+1}-s)} ds.$$

Then

$$(19) \quad \begin{aligned} V_e(t_{k+1}) &\leq e^{-2\alpha(t_{k+1}-t_{k-1})} V_e(t_{k-1}) + b\Delta^2 \int_{t_{k-1}}^{t_{k+1}} e^{-2\alpha(t_{k+1}-s)} ds \\ &\leq e^{-2\alpha(t_{k+1}-t_0)} V_e(t_0) + b\Delta^2 \int_{t_0}^{t_{k+1}} e^{-2\alpha(t_{k+1}-s)} ds. \end{aligned}$$

Replacing in (19)  $k+1$  by  $k$  and using (18), we arrive at (15), which yields  $x$ -ISS of (6)-(8) because

$$\lambda_{\min}(P) |x(t)|^2 \leq V(t, x_t, \dot{x}_t), \quad V(t_0, x_{t_0}, \dot{x}_{t_0}) \leq \delta \|x_{t_0}\|_W^2$$

for some scalar  $\delta > 0$ . Moreover, (19) with  $k+1$  replaced by  $k$  implies (16) since for  $t \in [t_k, t_{k+1})$

$$e^{-2\alpha(t_k-t_0)} = e^{-2\alpha(t-t_0)} e^{-2\alpha(t_k-t)} \leq \tilde{c} e^{-2\alpha(t-t_0)}.$$

■

By using Lemma 3.1 and the standard arguments for the delay-dependent analysis, we derive LMI conditions for ISS of (6)-(8) (see Appendix A for the proof):

**Theorem 3.2** Given  $0 \leq \eta_m < \tau_M$ ,  $\alpha > 0$ , assume that there exist positive scalar  $b$ ,  $n \times n$  matrices  $P > 0$ ,  $S_0 > 0$ ,  $R_0 > 0$ ,  $S_1 > 0$ ,  $R_1 > 0$ ,  $S_{12}$ ,  $n_i \times n_i$  matrices  $Q_i > 0$ ,  $U_i > 0$ ,  $G_i > 0$ ,  $i = 1, \dots, N$ , such that (13) and the following inequalities are feasible:

$$(20) \quad \Phi = \begin{bmatrix} R_1 & S_{12} \\ * & R_1 \end{bmatrix} \geq 0,$$

$$(21) \quad \begin{bmatrix} \Sigma_i - (F^i)^T \Phi F^i e^{-2\alpha\tau_M} & \Xi_i^T H \\ * & -H \end{bmatrix} < 0, \quad i = 1, \dots, N,$$

where

$$(22) \quad \begin{aligned} H &= \eta_m^2 R_0 + (\tau_M - \eta_m)^2 R_1 + (\tau_M - \eta_m) \sum_{l=1}^N C_l^T G_l C_l, \\ \Sigma_i &= (F_1^i)^T P \Xi_i + (\Xi^i)^T P F_1^i + \Upsilon_i - (F_2^i)^T R_0 F_2^i e^{-2\alpha\eta_m}, \\ F_1^i &= [I_n \quad 0_{n \times (3n+n_y-n_i+q)}], \\ F_2^i &= [I_n \quad -I_n \quad 0_{n \times (2n+n_y-n_i+q)}], \\ F^i &= \begin{bmatrix} 0_{n \times n} & I_n & -I_n & 0_{n \times n} & 0_{n \times (n_y-n_i+q)} \\ 0_{n \times n} & 0_{n \times n} & I_n & -I_n & 0_{n \times (n_y-n_i+q)} \end{bmatrix}, \\ \Xi_i &= [A \quad 0_{n \times n} \quad A_1 \quad 0_{n \times n} \quad B_2 \quad \dots \quad B_N \quad D], \quad i = 1, \\ \Xi_i &= [A \quad 0_{n \times n} \quad A_1 \quad 0_{n \times n} \quad B_1 \quad \dots \quad B_{j|j \neq i} \quad \dots \quad B_N \quad D], \quad i = 2, \dots, N, \\ \Upsilon_i &= \text{diag}\{S_0 + 2\alpha P, -(S_0 - S_1)e^{-2\alpha\eta_m}, 0_{n \times n}, -S_1 e^{-2\alpha\tau_M}, \psi_2, \dots, \psi_N, -bI_q\}, \quad i = 1, \\ \Upsilon_i &= \text{diag}\{S_0 + 2\alpha P, -(S_0 - S_1)e^{-2\alpha\eta_m}, 0_{n \times n}, -S_1 e^{-2\alpha\tau_M}, \psi_1; \dots \psi_{j|j \neq i}; \dots \psi_N, -bI_q\}, \\ & \quad i = 2, \dots, N, \quad \psi_j = -\frac{1}{\tau_M - \eta_m} U_j + 2\alpha Q_j, \quad j = 1, \dots, N. \end{aligned}$$

Then solutions of the hybrid system (6)-(8) satisfy the bound (15), where  $V(t, x_t, \dot{x}_t)$  is given by (10), implying ISS of (6)-(8). If the above LMIs are feasible with  $\alpha = 0$ , then the bound (15) holds with a small enough  $\alpha_0 > 0$ .

## 4 ISS under TOD/RR protocol: $N = 2$

For  $N = 2$  less restrictive conditions than those of Theorem 3.2 for the  $x$ -ISS of (6)-(7) will be derived via a different from (10) Lyapunov functional:

$$(23) \quad \begin{aligned} V_e(t) &= V(t, x_t, \dot{x}_t) + \frac{t_{k+1} - t}{\tau_M - \eta_m} \{e_i^T(t) Q_i e_i(t)\}_{i \neq i_k^*}, \\ Q_1 &> 0, \quad Q_2 > 0, \quad \alpha > 0, \quad t \in [t_k, t_{k+1}), \quad k \in \mathbb{Z}_+, \end{aligned}$$

where  $i_k^* \in \{1, 2\}$  and  $V(t, x_t, \dot{x}_t)$  is given by (10) with  $G_i = Q_i e^{2\alpha\tau_M}$ . The term  $\frac{t_{k+1} - t}{\tau_M - \eta_m} \{e_i^T(t) Q_i e_i(t)\}$  is inspired by the similar construction of Lyapunov functionals for the sampled-data systems [8, 18, 22]. The following statement holds:

**Lemma 4.1** Given  $N = 2$ , if there exist positive constants  $\alpha$ ,  $b$  and  $V_e(t)$  of (23) such that along (6)-(8) ((6), (7), (9)) the following inequality holds

$$(24) \quad \dot{V}_e(t) + 2\alpha V_e(t) - b|\omega(t)|^2 \leq 0, \quad t \in [t_k, t_{k+1}).$$

Then  $V_e(t)$  does not grow in the jumps along (6)-(8) ((6), (7), (9)), where

$$(25) \quad \Theta \triangleq V_e(t_{k+1}) - V_e(t_{k+1}^-) \leq 0.$$

The bound (15) is valid for a solution of (6)-(8) ((6), (7), (9)) with the initial condition  $x_{t_0} \in W[-\tau_M, 0]$ ,  $e(t_0) \in \mathbb{R}^{n_y}$ , implying the  $x$ -ISS of (6)-(8) ((6), (7), (9)).

**Proof.** Since  $|\omega(t)| \leq \Delta$ , (24) implies

$$(26) \quad V_e(t) \leq e^{-2\alpha(t-t_k)} V_e(t_k) + b\Delta^2 \int_{t_k}^t e^{-2\alpha(t-s)} ds, \quad t \in [t_k, t_{k+1}).$$

Noting that

$$\begin{aligned} V_e(t_{k+1}) &\leq \tilde{V}|_{t=t_{k+1}} + |\sqrt{Q_i}e_i(t_{k+1})|_{|i \neq i_{k+1}^*}|^2 \\ &\quad + \sum_{i=1}^2 (\tau_M - \eta_m) \int_{t_{k+1} - \eta_{k+1}}^{t_{k+1}} e^{2\alpha(s-t_{k+1})} |\sqrt{G_i}C_i \dot{x}(s)|^2 ds, \end{aligned}$$

we obtain employing (11)

$$\begin{aligned} \Theta &\leq e_i^T(t_{k+1})Q_i e_i(t_{k+1})_{|i \neq i_{k+1}^*} + V_G|_{t=t_{k+1}} - V_G|_{t=t_{k+1}^-} \\ &\leq e_i^T(t_{k+1})Q_i e_i(t_{k+1})_{|i \neq i_{k+1}^*} - \sum_{i=1}^2 |\sqrt{Q_i}C_i[x(t_k - \eta_k) - x(t_{k+1} - \eta_{k+1})]|^2. \end{aligned}$$

We will prove that  $\Theta \leq 0$  under TOD and RR protocols, respectively. Under TOD protocol we have

$$e_i^T(t_{k+1})Q_i e_i(t_{k+1})_{|i \neq i_{k+1}^*} \leq e_{i_k^*}^T(t_{k+1})Q_{i_k^*} e_{i_k^*}(t_{k+1})$$

for  $i_{k+1}^* = i_k^*$ , whereas

$$(27) \quad e_i^T(t_{k+1})Q_i e_i(t_{k+1})_{|i \neq i_{k+1}^*} = e_{i_k^*}^T(t_{k+1})Q_{i_k^*} e_{i_k^*}(t_{k+1})$$

for  $i_{k+1}^* \neq i_k^*$ . Then, taking into account (7) we obtain

$$\begin{aligned} \Theta &\leq |\sqrt{Q_i}C_i[x(t_k - \eta_k) - x(t_{k+1} - \eta_{k+1})]|_{|i=i_k^*}|^2 \\ &\quad - \sum_{i=1}^2 |\sqrt{Q_i}C_i[x(t_k - \eta_k) - x(t_{k+1} - \eta_{k+1})]|^2 \leq 0. \end{aligned}$$

Under RR protocol we have  $i_{k+1}^* \neq i_k^*$  meaning that (27) holds and that  $\Theta \leq 0$ . Then the result follows by the arguments of Lemma 3.1. ■

**Remark 4.2** *Differently from Lemma 3.1, Lemma 4.1 guarantees (19) that does not give a bound on  $e_{i_k^*}(t_k)$  since  $V_e(t)$  for  $t \in [t_k, t_{k+1})$  does not depend on  $e_{i_k^*}(t_k)$ . That is why Lemma 4.1 guarantees only  $x$ -ISS. However, as explained in Remark 5.3 below, under RR protocol  $x$ -ISS implies boundedness of  $e$ .*

In the next section, we will extend the result of Lemma 4.1 under RR protocol to the case of  $N \geq 2$ . Theorem 5.2 below (in the particular case of  $N = 2$ ) will provide LMIs for the  $x$ -ISS of (6)-(8) ((6), (7), (9)).

## 5 ISS under RR protocol: $N \geq 2$

Under RR protocol (9), the reset system (7) can be rewritten as

$$(28) \quad \begin{aligned} x(t_{k+1}) &= x(t_{k+1}^-), \\ e_{i_{k-j}^*}(t_{k+1}) &= C_{i_{k-j}^*} [x(s_{k-j}) - x(s_{k+1})], \\ j &= 0, \dots, N-1 \text{ if } k \geq N-1, \end{aligned}$$

where the index  $k-j$  corresponds to the last updated measurement in the node  $i_{k-j}^*$ .

Consider the following Lyapunov functional:

$$(29) \quad \begin{aligned} V_e(t) &= V(t, x_t, \dot{x}_t) + V_Q, \quad t \geq t_{N-1}, \\ V(t, x_t, \dot{x}_t) &= \tilde{V}(t, x_t, \dot{x}_t) + V_G, \end{aligned}$$

where  $\tilde{V}(t, x_t, \dot{x}_t)$  is given by (10). The discontinuous in time terms  $V_Q$  and  $V_G$  are defined as follows:

$$(30) \quad \begin{aligned} V_Q &= \sum_{j=1}^{N-1} \frac{t_{k+1}-t}{j(\tau_M-\eta_m)} |\sqrt{Q_{i_{k-j}^*}} e_{i_{k-j}^*}(t)|^2, \quad k \geq N-1, \quad t \in [t_k, t_{k+1}), \\ V_G &= \begin{cases} \sum_{i=1}^N (\tau_M - \eta_m) \int_{s_k}^t e^{2\alpha(s-t)} |\sqrt{G_i} C_i \dot{x}(s)|^2 ds, & k \geq N, \quad t \in [t_k, t_{k+1}), \\ \sum_{i=1}^N (\tau_M - \eta_m) \int_{s_0}^t e^{2\alpha(s-t)} |\sqrt{G_i} C_i \dot{x}(s)|^2 ds, & t \in [t_{N-1}, t_N), \end{cases} \end{aligned}$$

where for  $i = 1, \dots, N$

$$(31) \quad G_i = (N-1)Q_i e^{2\alpha[\tau_M+(N-2)(\tau_M-\eta_m)]} > 0.$$

Here  $V_e$  does not depend on  $e_{i_k}(t_k)$ . Note that given  $i = 1, \dots, N$ ,  $e_i$ -term appears  $N-1$  times in  $V_Q$  for every  $N$  intervals  $[t_{k+j}, t_{k+j+1})$ ,  $j = 0, \dots, N-1$  (except of the interval with  $i_{k+j}^* = i$ ). This motivates  $N-1$  in (31) because  $V_G$  is supposed to compensate  $V_Q$  term.

As in the previous sections, the term  $V_G$  is inserted to cope with the delays in the reset conditions. It is continuous on  $[t_k, t_{k+1})$  and does not grow in the jumps (when  $t = t_{k+1}$ ), since for  $k > N-1$  (cf. (11))

$$(32) \quad V_G|_{t=t_{k+1}} - V_G|_{t=t_{k+1}^-} \leq -\sum_{i=1}^N (\tau_M - \eta_m) \int_{s_k}^{s_{k+1}} e^{2\alpha(s-t_{k+1})} |\sqrt{G_i} C_i \dot{x}(s)|^2 ds$$

and for  $k = N-1$

$$(33) \quad V_G|_{t=t_N} - V_G|_{t=t_N^-} \leq -\sum_{i=1}^N (\tau_M - \eta_m) \int_{s_0}^{s_N} e^{2\alpha(s-t_N)} |\sqrt{G_i} C_i \dot{x}(s)|^2 ds.$$

The term  $V_Q$  grows in the jumps as follows:

$$\begin{aligned} V_Q|_{t=t_{k+1}} - V_Q|_{t=t_{k+1}^-} &= \sum_{j=1}^{N-1} \frac{t_{k+2}-t_{k+1}}{j(\tau_M-\eta_m)} |\sqrt{Q_{i_{k+1-j}^*}} e_{i_{k+1-j}^*}(t_{k+1})|^2 \\ &\leq \sum_{j=0}^{N-2} \frac{1}{j+1} |\sqrt{Q_{i_{k-j}^*}} C_{i_{k-j}^*} [x(s_{k-j}) - x(s_{k+1})]|^2 \\ &\leq \sum_{j=0}^{N-2} (\tau_M - \eta_m) \int_{s_{k-j}}^{s_{k+1}} |\sqrt{Q_{i_{k-j}^*}} C_{i_{k-j}^*} \dot{x}(s)|^2 ds, \end{aligned}$$

where we have used Jensen's inequality and the bound

$$(34) \quad \begin{aligned} s_{k+1} - s_{k-j} &= s_{k+1} - s_k + s_k - \cdots + s_{k-j+1} - s_{k-j} \\ &\leq (j+1)(\tau_M - \eta_m). \end{aligned}$$

Since  $1 \leq e^{2\alpha[\tau_M+(N-2)(\tau_M-\eta_m)]}e^{2\alpha(s_k-j-t_{k+1})}$  for  $j = 0, \dots, N-2$ , we obtain

$$(35) \quad \begin{aligned} V_Q|_{t=t_{k+1}} - V_Q|_{t=t_{k+1}^-} &\leq \sum_{j=0}^{N-2} (\tau_M - \eta_m) e^{2\alpha[\tau_M+(N-2)(\tau_M-\eta_m)]} \\ &\quad \times \int_{s_{k-j}}^{s_{k+1}} e^{2\alpha(s-t_{k+1})} |\sqrt{Q_{i_{k-j}^*}} C_{i_{k-j}^*} \dot{x}(s)|^2 ds. \end{aligned}$$

The following lemma gives sufficient conditions for the  $x$ -ISS of (6), (9), (28) (see Appendix B for proof):

**Lemma 5.1** *If there exist positive constants  $\alpha$ ,  $b$  and  $V_e(t)$  of (29) such that along (6), (9), (28) the inequality (24) is satisfied for  $k \geq N-1$ . Then the following bound holds along the solutions of (6), (9), (28):*

$$(36) \quad \begin{aligned} V_e(t_{k+1}) &\leq e^{-2\alpha(t_{k+1}-t_{N-1})} V_e(t_{N-1}) + \Psi_{k+1} \\ &\quad + b\Delta^2 \int_{t_{N-1}}^{t_{k+1}} e^{-2\alpha(t_{k+1}-s)} ds, \quad k \geq N-1, \end{aligned}$$

where

$$(37) \quad \begin{aligned} \Psi_{k+1} &= -(\tau_M - \eta_m) e^{2\alpha[\tau_M+(N-2)(\tau_M-\eta_m)]} \\ &\quad \times \left[ \sum_{j=0}^{N-3} (N-2-j) \int_{s_{k-j-1}}^{s_{k+1}} e^{2\alpha(s-t_{k+1})} |\sqrt{Q_{i_{k-j}^*}} C_{i_{k-j}^*} \dot{x}(s)|^2 ds \right. \\ &\quad \left. + (N-1) \int_{s_k}^{s_{k+1}} e^{2\alpha(s-t_{k+1})} |\sqrt{Q_{i_{k+1}^*}} C_{i_{k+1}^*} \dot{x}(s)|^2 ds \right] \leq 0. \end{aligned}$$

Moreover, for all  $t \geq t_{N-1}$

$$(38) \quad \begin{aligned} V(t, x_t, \dot{x}_t) &\leq e^{-2\alpha(t-t_{N-1})} V_e(t_{N-1}) + \frac{b}{2\alpha} \Delta^2, \\ V_e(t_{N-1}) &= V(t_{N-1}, x_{t_{N-1}}, \dot{x}_{t_{N-1}}) + \sum_{i=1}^N |\sqrt{Q_i} e_i(t_{N-1})|^2. \end{aligned}$$

The latter inequality guarantees the  $x$ -ISS of (6), (9), (28) for  $t \geq t_{N-1}$ .

By using Lemma 5.1, arguments of Theorem 3.2 and the fact that for  $j = 1, \dots, N-1$

$$\frac{d}{dt} \frac{t_{k+1}-t}{j(\tau_M-\eta_m)} = -\frac{1}{j(\tau_M-\eta_m)} \leq -\frac{1}{(N-1)(\tau_M-\eta_m)},$$

we arrive at the the following result:

**Theorem 5.2** *Given  $0 \leq \eta_m < \tau_M$  and  $\alpha > 0$ , assume that there exist positive scalar  $b$ ,  $n \times n$  matrices  $P > 0$ ,  $S_0 > 0$ ,  $R_0 > 0$ ,  $S_1 > 0$ ,  $R_1 > 0$ ,  $S_{12}$  and  $n_i \times n_i$  matrices  $Q_i > 0$  ( $i = 1, \dots, N$ ) such that (20) and (21) are feasible with  $U_i = \frac{Q_i}{N-1}$ , where  $G_i$  is given by (31). Then for  $N > 2$  solutions of the hybrid system (6), (9), (28) satisfy the bound (38) with  $V(t, x_t, \dot{x}_t)$  given by (29), meaning  $x$ -ISS for  $t \geq t_{N-1}$ . For  $N = 2$  solutions of the hybrid system (6)-(8) ((6), (7), (9)) satisfy the bound (15) meaning  $x$ -ISS (for  $t \geq t_0$ ). Moreover, if the above LMIs are feasible with  $\alpha = 0$ , then the solution bounds hold with a small enough  $\alpha_0 > 0$ .*

**Remark 5.3** For  $N = 2$  and  $\alpha = 0$ , the LMIs of Theorem 3.2 are more restrictive than those of Theorem 5.2: (13) of Theorem 3.2 yields  $(N-1)U_i < Q_i < G_i$ , whereas in Theorem 5.2 we have  $(N-1)^2U_i = (N-1)Q_i = G_i$  that leads to larger  $U_i$  for the same  $G_i$ . The latter helps for the feasibility of (21), where  $U_i > 0$  appears on the main diagonal only (with minus). However, Theorem 3.2 achieves ISS with respect to the full state  $\text{col}\{x, e\}$  and provides the solution bound for  $t \geq t_0$ , while Theorem 5.2 guarantees only  $x$ -ISS.

Note that Theorem 5.2 under RR protocol guarantees boundedness of  $e$  as well. Indeed, since  $e(t_N)$  in (28) depends on  $x(0), \dots, x(t_N - \eta_N)$  and  $t_N \leq N\tau_M$  (this can be verified similar to (34)), relations (28) yield

$$|e_i(t)|^2 \leq c' \sup_{\theta \in [-N\tau_M, 0]} |x(t + \theta)|^2, \quad t \geq t_N$$

with some  $c' > 0$ , which together with (38) imply

$$|e_i(t)|^2 \leq c'' [e^{-2\alpha(t-t_{N-1})} V_e(t_{N-1}) + \Delta^2]$$

for some  $c'' > 0$  and all  $t \geq t_N + N\tau_M$ .

**Remark 5.4** The LMIs of Theorems 3.2 and 5.2 are affine in the system matrices. Therefore, in the case of system matrices from an uncertain time-varying polytope

$$\begin{aligned} \Omega &= \sum_{j=1}^M g_j(t) \Omega_j, \quad 0 \leq g_j(t) \leq 1, \\ \sum_{j=1}^M g_j(t) &= 1, \quad \Omega_j = \begin{bmatrix} A^{(j)} & B^{(j)} & D^{(j)} \end{bmatrix}, \end{aligned}$$

one have to solve these LMIs simultaneously for all the  $M$  vertices  $\Omega_j$ , applying the same decision matrices.

## 6 Examples

### 6.1 Example 1: uncertain inverted pendulum

Consider an inverted pendulum mounted on a small car. We focus on the stability analysis in the absence of disturbance. Following [13], we assume that the friction coefficient between the air and the car,  $f_c$ , and the air and the bar,  $f_b$ , are not exactly known and time-varying:  $f_c(t) \in [0.15, 0.25]$  and  $f_b(t) \in [0.15, 0.25]$ . The linearized model can be written as (1), where the matrices  $A = E^{-1}A_f$  and  $B = E^{-1}B_0$  are determined from

$$E = \begin{bmatrix} 1 & 0 & 0 & 0 \\ 0 & 1 & 0 & 0 \\ 0 & 0 & 3/2 & -1/4 \\ 0 & 0 & -1/4 & 1/6 \end{bmatrix},$$

$$A_f = \begin{bmatrix} 0 & 0 & 1 & 0 \\ 0 & 0 & 0 & 1 \\ 0 & 0 & -(f_c + f_b) & f_b/2 \\ 0 & 5/2 & f_b/2 & -f_b/3 \end{bmatrix} \quad \text{and} \quad B_0 = \begin{bmatrix} 0 \\ 0 \\ 1 \\ 0 \end{bmatrix}.$$

Here  $A$  belongs to uncertain polytope, defined by four vertices corresponding to  $f_c/f_b = 0.15$  and  $f_c/f_b = 0.25$ . The pendulum can be stabilized by a state feedback  $u(t) = Kx(t)$ , where  $x = [x_1, x_2, x_3, x_4]^T$ , with the gain

$$(39) \quad K = [11.2062 \quad -128.8597 \quad 10.7823 \quad -22.2629].$$

In this model,  $x_1$  and  $x_2$  represent cart position and velocity, whereas  $x_3, x_4$  represent pendulum angle from vertical and its angular velocity respectively. In practice  $x_1, x_2$  and  $x_3, x_4$  (presenting spatially distributed components of the state of the pendulum-cart system) are not accessible simultaneously. Suppose that the state variables are not accessible simultaneously. Consider first  $N = 2$  and

$$C_1 = \begin{bmatrix} 1 & 0 & 0 & 0 \\ 0 & 1 & 0 & 0 \end{bmatrix}, \quad C_2 = \begin{bmatrix} 0 & 0 & 1 & 0 \\ 0 & 0 & 0 & 1 \end{bmatrix}.$$

The applied controller gain  $K$  has the following blocks:

$$K_1 = [ 11.2062 \quad -128.8597 ], \quad K_2 = [ 10.7823 \quad -22.2629 ].$$

For the values of  $\eta_m$  given in Table 1, we apply Theorems 3.2 and 5.2 with  $\alpha = 0, b = 0$  via Remark 5.4 and find the maximum values of  $\tau_M = \text{MATI} + \text{MAD}$  that preserve the stability of the hybrid system (6)-(7) with  $\omega(t) = 0$  with respect to  $x$ . From Table 1, it is observed that under TOD or RR protocol the conditions of Theorem 5.2 possess less decision variables, and stabilize the system for larger  $\tau_M$  than the results in [16] under RR protocol. Moreover, when  $\eta_m > \frac{\tau_M}{2}$  ( $\eta_m = 0.02, 0.04$ ), our method is still feasible (communication delays are larger than the sampling intervals). The computational time for solving the LMIs (in seconds) under the TOD protocol is essentially less than that under RR protocol in [16] (till 36% decrease).

Table 1: Example 1 (N=2): max. value of  $\tau_M = \text{MATI} + \text{MAD}$

$\tau_M \setminus \eta_m$	0	0.005	0.01	0.02	0.04	Decision variables
[16] (RR)	0.023	0.026	0.029	0.035	0.046	146
Theorem 3.2 (TOD)	0.014	0.018	0.021	0.029	0.044	84
Theorem 5.2 (TOD/RR)	0.025	0.028	0.031	0.036	0.047	72

Consider next  $N = 4$ , where  $C_1, \dots, C_4$  are the rows of  $I_4$  and  $K_1, \dots, K_4$  are the entries of  $K$  given by (39). Here the maximum values of  $\tau_M$  that preserve the stability of (6)-(7) with  $\omega(t) = 0$  with respect to  $x$  are given in Table 2. Also here Theorem 5.2 leads to less conservative results than Theorem 3.2.



Table 2: Example 1 (N=4): max. value of  $\tau_M = \text{MATI} + \text{MAD}$

$\tau_M \setminus \eta_m$	0	0.01
Theorem 3.2 (TOD)	0.003	0.012
Theorem 5.2 (RR)	0.006	0.015

## 6.2 Example 2: batch reactor

We illustrate the efficiency of the given conditions on the example of a batch reactor under the dynamic output feedback (see e.g., [15]), where  $N = 2$  and

$$A = \begin{bmatrix} 1.380 & -0.208 & 6.715 & -5.676 \\ -0.581 & -4.2902 & 0 & 0.675 \\ 1.067 & 4.273 & -6.654 & 5.893 \\ 0.048 & 4.273 & 1.343 & -2.104 \end{bmatrix},$$

$$B = \begin{bmatrix} 0 & 0 \\ 5.679 & 0 \\ 1.136 & -3.146 \\ 1.136 & 0 \end{bmatrix}, \quad C = \begin{bmatrix} C_1 \\ C_2 \end{bmatrix} = \begin{bmatrix} 1 & 0 & 1 & -1 \\ 0 & 1 & 0 & 0 \end{bmatrix},$$

$$\left[ \begin{array}{c|c} A_c & B_c \\ \hline C_c & D_c \end{array} \right] = \left[ \begin{array}{cc|cc} 0 & 0 & 0 & 1 \\ 0 & 0 & 1 & 0 \\ \hline -2 & 0 & 0 & -2 \\ 0 & 8 & 5 & 0 \end{array} \right].$$

For the values of  $\eta_m$  given in Table 3, we apply Theorems 3.2 and 5.2 with  $\alpha = 0$ ,  $b = 0$  and find the maximum values of  $\tau_M = \text{MATI} + \text{MAD}$  that preserve the stability of the hybrid system (6)-(7) with  $\omega(t) = 0$  with respect to  $x$ . From Table 3 it is seen that the results of our method essentially improve the results in [15], and are more conservative than those obtained via the discrete-time approach. Recently in [2] the same result  $\tau_M = 0.035$  as ours in Theorem 5.2 for  $\eta_m = 0$ ,  $\text{MAD} = 0.01$  has been achieved. In [2] the sum of squares method is developed in the framework of hybrid system approach. We note that the sum of squares method has not been applied yet to ISS. Moreover, our conditions are simple LMIs with a fewer decision variables. When  $\eta_m > \frac{\tau_M}{2}$  ( $\eta_m = 0.03, 0.04$ ), our method is still feasible (communication delays are larger than the sampling intervals). The computational time under the TOD protocol is essentially less than that under RR protocol in [16] (till 32% decrease).

## 7 Conclusions

In this paper, a time-delay approach has been developed for the ISS of NCS with scheduling protocols, variable transmission delays and variable sampling intervals. A novel hybrid system model with time-varying delays in the continuous dynamics and in the reset equations is introduced and a new Lyapunov-

Table 3: Example 2: max. value of  $\tau_M = \text{MATI} + \text{MAD}$  for different  $\eta_m$

$\tau_M \setminus \eta_m$	0	0.004	0.01	0.02	0.03	0.04
[15](MAD = 0.004)	0.0108	0.0133	-	-	-	-
[6](MAD = 0.03)	0.069	0.069	0.069	0.069	0.069	-
Theorem 3.2 (TOD)	0.019	0.022	0.027	0.034	0.042	0.050
Theorem 5.2 (TOD/RR)	0.035	0.037	0.041	0.047	0.053	0.059
[16] (RR)	0.042	0.044	0.048	0.053	0.058	0.063

Krasovskii method is developed. The ISS conditions of the delayed hybrid system are derived in terms of LMIs. Differently from the existing (hybrid and discrete-time) methods on the stabilization of NCS with scheduling protocols, the time-delay approach allows non-small network-induced delay (which is not smaller than the sampling interval). Future work will involve consideration of more general NCS models, including packet dropouts, packet disordering, quantization and scheduling protocols for the actuator nodes.

## A Proof of Theorem 3.2

**Proof.** Consider  $t \in [t_k, t_{k+1})$ ,  $k \in \mathbb{Z}_+$  and define  $\xi_i(t) = \text{col}\{x(t), x(t - \eta_m), x(t - \tau(t)), x(t - \tau_M), e_1(t), \dots, e_j(t), \dots, e_N(t), \omega(t)\}$  with  $i = i_k^* \in \mathbb{N}$ ,  $j \neq i$ . Differentiating  $V_e(t)$  along (6) and applying Jensen's inequality, we have

$$\begin{aligned}
& \eta_m \int_{t-\eta_m}^t \dot{x}^T(s) R_0 \dot{x}(s) ds \geq \int_{t-\eta_m}^t \dot{x}^T(s) ds R_0 \int_{t-\eta_m}^t \dot{x}(s) ds \\
& \quad = \xi_i^T(t) (F_2^i)^T R_0 F_2^i \xi_i(t), \\
& -(\tau_M - \eta_m) \int_{t-\tau_M}^{t-\eta_m} \dot{x}^T(s) R_1 \dot{x}(s) ds \\
& = -(\tau_M - \eta_m) \int_{t-\tau(t)}^{t-\eta_m} \dot{x}^T(s) R_1 \dot{x}(s) ds - (\tau_M - \eta_m) \int_{t-\tau_M}^{t-\tau(t)} \dot{x}^T(s) R_1 \dot{x}(s) ds \\
& \leq -\frac{\tau_M - \eta_m}{\tau(t) - \eta_m} \xi_i^T(t) \begin{bmatrix} I_n & 0_{n \times n} \end{bmatrix} F^i \begin{bmatrix} I_n & 0_{n \times n} \end{bmatrix}^T R_1 \begin{bmatrix} I_n & 0_{n \times n} \end{bmatrix} F^i \xi_i(t) \\
& \quad - \frac{\tau_M - \eta_m}{\tau_M - \tau(t)} \xi_i^T(t) \begin{bmatrix} 0_{n \times n} & I_n \end{bmatrix} F^i \begin{bmatrix} 0_{n \times n} & I_n \end{bmatrix}^T R_1 \begin{bmatrix} 0_{n \times n} & I_n \end{bmatrix} F^i \xi_i(t) \\
& \leq -\xi_i^T(t) (F^i)^T \Phi \tilde{F}^i \xi_i(t).
\end{aligned}$$

The latter inequality holds if (20) is feasible [21]. Then

$$\begin{aligned}
& \dot{V}_e(t) + 2\alpha V_e(t) - \frac{1}{\tau_M - \eta_m} \sum_{l=1, l \neq i}^N |\sqrt{U_l} e_l(t)|^2 - 2\alpha |\sqrt{Q_i} e_i(t)|^2 - b |\omega(t)|^2 \\
& \leq \xi_i^T(t) [\Sigma_i + \Xi_i^T H \Xi_i - (F^i)^T \Phi \tilde{F}^i e^{-2\alpha \tau_M}] \xi_i(t) \leq 0,
\end{aligned}$$

if  $\Sigma_i + \Xi_i^T H \Xi_i - (F^i)^T \Phi \tilde{F}^i e^{-2\alpha \tau_M} < 0$ , i.e., by Schur complement, if (21) is feasible. Thus due to Lemma 3.1, inequalities (13), (20) and (21) imply (15). ■

## B Proof of Lemma 5.1

**Proof.** Since  $|\omega(t)| \leq \Delta$ , (24) implies

$$(40) \quad \begin{aligned} V(t, x_t, \dot{x}_t) &\leq V_e(t) \\ &\leq e^{-2\alpha(t-t_k)} V_e(t_k) + b\Delta^2 \int_{t_k}^t e^{-2\alpha(t-s)} ds, \quad t \in [t_k, t_{k+1}). \end{aligned}$$

Note that  $V_e(t_{k+1}) = \tilde{V}_{|t=t_{k+1}} + V_{Q|t=t_{k+1}} + V_{G|t=t_{k+1}}$ . Taking into account (28) and the relations  $\tilde{V}_{t=t_{k+1}} = \tilde{V}_{t=t_{k+1}^-}$ ,  $e(t_{k+1}) = e(t_k)$ , we obtain due to (31), (32) and (35) for  $k > N - 1$

$$(41) \quad \begin{aligned} \Theta_{k+1} &\triangleq V_e(t_{k+1}) - V_e(t_{k+1}^-) \\ &= [V_Q + V_G]_{t=t_{k+1}} - [V_Q + V_G]_{t=t_{k+1}^-} \\ &\leq (\tau_M - \eta_m) e^{2\alpha[\tau_M + (N-2)(\tau_M - \eta_m)]} \left[ \sum_{j=0}^{N-2} \int_{s_{k-j}}^{s_{k+1}} e^{2\alpha(s-t_{k+1})} \left| \sqrt{Q_{i_{k-j}}^*} C_{i_{k-j}}^* \dot{x}(s) \right|^2 ds \right. \\ &\quad \left. - \sum_{i=1}^N (N-1) \int_{s_k}^{s_{k+1}} e^{2\alpha(s-t_{k+1})} \left| \sqrt{Q_i} C_i \dot{x}(s) \right|^2 ds \right], \end{aligned}$$

whereas for  $k = N - 1$  due to (33) and (35)

$$\begin{aligned} \Theta_N &\leq \sum_{j=0}^{N-2} (\tau_M - \eta_m) e^{2\alpha[\tau_M + (N-2)(\tau_M - \eta_m)]} \\ &\quad \times \int_{s_{N-1-j}}^{s_N} e^{2\alpha(s-t_N)} \left| \sqrt{Q_{i_{N-1-j}}^*} C_{i_{N-1-j}}^* \dot{x}(s) \right|^2 ds \\ &\quad - \sum_{i=1}^N (\tau_M - \eta_m) \int_{s_0}^{s_N} e^{2\alpha(s-t_N)} \left| \sqrt{Q_i} C_i \dot{x}(s) \right|^2 ds \\ &\leq -(\tau_M - \eta_m) e^{2\alpha[\tau_M + (N-2)(\tau_M - \eta_m)]} \int_{s_0}^{s_N} e^{2\alpha(s-t_N)} \\ &\quad \times [(N-2) \sum_{i=1}^N \left| \sqrt{Q_i} C_i \dot{x}(s) \right|^2 + \left| \sqrt{Q_l} C_l \dot{x}(s) \right|_{l=i_N}^2] ds. \end{aligned}$$

We will prove (36) by induction. For  $k = N - 1$  we have

$$\begin{aligned} V_e(t_N) &\leq \Theta_N + V_e(t_N^-) \\ &\leq -(\tau_M - \eta_m) e^{2\alpha[\tau_M + (N-2)(\tau_M - \eta_m)]} \\ &\quad \times \int_{s_0}^{s_N} e^{2\alpha(s-t_N)} [(N-2) \sum_{i=1}^N \left| \sqrt{Q_i} C_i \dot{x}(s) \right|^2 + \left| \sqrt{Q_l} C_l \dot{x}(s) \right|_{l=i_N}^2] ds \\ &\quad + e^{-2\alpha(t_N - t_{N-1})} V_e(t_{N-1}) + b\Delta^2 \int_{t_{N-1}}^{t_N} e^{-2\alpha(t_N - s)} ds, \end{aligned}$$

which implies (36).

Assume that (36) holds for  $k - 1$  ( $k \geq N - 1$ ):

$$V_e(t_k) \leq e^{-2\alpha(t_k - t_{N-1})} V_e(t_{N-1}) + \Psi_k + b\Delta^2 \int_{t_{N-1}}^{t_k} e^{-2\alpha(t_k - s)} ds.$$

Then due to (40) for  $t = t_{k+1}^-$  we obtain

$$\begin{aligned} V_e(t_{k+1}) &\leq \Theta_{k+1} + e^{-2\alpha(t_{k+1} - t_k)} \Psi_k + e^{-2\alpha(t_{k+1} - t_{N-1})} V_e(t_{N-1}) \\ &\quad + b\Delta^2 \int_{t_{N-1}}^{t_{k+1}} e^{-2\alpha(t_{k+1} - s)} ds. \end{aligned}$$

We have

$$\begin{aligned}
e^{-2\alpha(t_{k+1}-t_k)}\Psi_k &= -(\tau_M - \eta_m)e^{2\alpha[\tau_M+(N-2)(\tau_M-\eta_m)]} \\
&\times \left[ \sum_{l=0}^{N-3} (N-2-l) \int_{s_{k-l-2}}^{s_k} e^{2\alpha(s-t_{k+1})} \times |\sqrt{Q_{i_{k-1-l}^*}} C_{i_{k-1-l}^*} \dot{x}(s)|^2 ds \right. \\
&\quad \left. + (N-1) \int_{s_{k-1}}^{s_k} e^{2\alpha(s-t_{k+1})} |\sqrt{Q_{i_k^*}} C_{i_k^*} \dot{x}(s)|^2 ds \right] \\
&= -(\tau_M - \eta_m)e^{2\alpha[\tau_M+(N-2)(\tau_M-\eta_m)]} \left[ \sum_{j=0}^{N-2} (N-1-j) \right. \\
&\quad \left. \times \int_{s_{k-j-1}}^{s_k} e^{2\alpha(s-t_{k+1})} |\sqrt{Q_{i_{k-j}^*}} C_{i_{k-j}^*} \dot{x}(s)|^2 ds \right].
\end{aligned}$$

Then, taking into account (41), we find

$$\begin{aligned}
\Theta_{k+1} + e^{-2\alpha(t_{k+1}-t_k)}\Psi_k &\leq (\tau_M - \eta_m)e^{2\alpha[\tau_M+(N-2)(\tau_M-\eta_m)]} \\
&\times \left[ \sum_{j=0}^{N-2} \int_{s_{k-j-1}}^{s_{k+1}} e^{2\alpha(s-t_{k+1})} |\sqrt{Q_{i_{k-j}^*}} C_{i_{k-j}^*} \dot{x}(s)|^2 ds \right. \\
&\quad - \sum_{i=1}^N (N-1) \int_{s_k}^{s_{k+1}} e^{2\alpha(s-t_{k+1})} |\sqrt{Q_i} C_i \dot{x}(s)|^2 ds \\
&\quad \left. - \sum_{j=0}^{N-2} (N-1-j) \int_{s_{k-j-1}}^{s_k} e^{2\alpha(s-t_{k+1})} \times |\sqrt{Q_{i_{k-j}^*}} C_{i_{k-j}^*} \dot{x}(s)|^2 ds \right] \\
&\leq -(\tau_M - \eta_m)e^{2\alpha[\tau_M+(N-2)(\tau_M-\eta_m)]} \\
&\times \left[ \sum_{j=0}^{N-2} (N-2-j) \int_{s_{k-j-1}}^{s_{k+1}} e^{2\alpha(s-t_{k+1})} \times |\sqrt{Q_{i_{k-j}^*}} C_{i_{k-j}^*} \dot{x}(s)|^2 ds \right. \\
&\quad \left. + (N-1) \int_{s_k}^{s_{k+1}} e^{2\alpha(s-t_{k+1})} |\sqrt{Q_{i_{k+1}^*}} C_{i_{k+1}^*} \dot{x}(s)|^2 ds \right] \\
&= \Psi_{k+1},
\end{aligned}$$

which implies (36). Hence, (36) and (40) yield (38). ■

## References

- [1] P. Antsaklis and J. Baillieul. Special issue on technology of networked control systems. *Proceedings of the IEEE*, 95(1), 5–8, 2007.
- [2] N.W. Bauer, P.J.H. Maas and W.P.M.H. Heemels. Stability analysis of networked control systems: A sum of squares approach. *Automatica*, 48, 1514–1524, 2012.
- [3] M.B.G. Cloosterman, L. Hetel, N. van de Wouw, W.P.M.H. Heemels, J. Daafouz and H. Nijmeijer. Controller synthesis for networked control systems. *Automatica*, 46(10), 1584–1594, 2010.
- [4] D. Christmann, R. Gotzhein, S. Siegmund and F. Wirth. Realization of Try-Once-Discard in Wireless Multi-hop Networks. In *Proceedings of the 18th World IFAC Congress*, Milano, Italy, 2011.
- [5] D. Dacic and D. Nesic. Quadratic stabilization of linear networked control systems via simultaneous protocol and controller design. *Automatica*, 43, 1145–1155, 2007.

- [6] M.C.F. Donkers, W.P.M.H. Heemels, N. van de Wouw and L. Hetel. Stability analysis of networked control systems using a switched linear systems approach. *IEEE Transactions on Automatic Control*, 56(9), 2101-2115, 2011.
- [7] E. Fridman. Use of models with aftereffect in the problem of design of optimal digital control. *Automation and Remote Control*, 53(10), 1523-1528, 1992.
- [8] E. Fridman. A refined input delay approach to sampled-data control. *Automatica*, 46, 421-427, 2010.
- [9] E. Fridman, A. Seuret and J.P. Richard. Robust sampled-data stabilization of linear systems: an input delay approach. *Automatica*, 40, 1441-1446, 2004.
- [10] H. Fujioka. A discrete-time approach to stability analysis of systems with aperiodic sample-and-hold devices. *IEEE Transactions on Automatic Control*, 54(10), 2440-2445, 2009.
- [11] H. Gao, T. Chen and T. Chai. Passivity and passification for networked control systems. *SIAM Journal on Control and Optimization*, 46(4): 1299-1322, 2007.
- [12] H. Gao, X. Meng, T. Chen and J. Lam. Stabilization of networked control systems via dynamic output-feedback controllers. *SIAM Journal on Control and Optimization*, 48(5): 3643-3658, 2010.
- [13] J.C. Geromel, R.H. Korogui and J. Bernussou.  $H_2$  and  $H_\infty$  robust output feedback control for continuous time polytopic systems. *IET Control Theory & Applications*, 1(5), 1541-1549, 2007.
- [14] K. Gu, V. Kharitonov and J. Chen. *Stability of time-delay systems*. Birkhauser: Boston, 2003.
- [15] W.P.M.H. Heemels, A.R. Teel, N. van de Wouw and D. Nesic. Networked control systems with communication constraints: tradeoffs between transmission intervals, delays and performance. *IEEE Transactions on Automatic Control*, 55(8), 1781-1796, 2010.
- [16] K. Liu, E. Fridman and L. Hetel. Stability and  $L_2$ -gain analysis of networked control systems under Round-Robin scheduling: a time-delay approach. *Systems & Control Letters*, 61(5): 666-675, 2012.
- [17] K. Liu, E. Fridman and L. Hetel. Network-based control via a novel analysis of hybrid systems with time-varying delays. In *Proceedings of the 51th IEEE Conference on Decision and Control*, Maui, Hawaii, 2012.
- [18] P. Naghshtabrizi, J. Hespanha and A.R. Teel. Exponential stability of impulsive systems with application to uncertain sampled-data systems. *Systems & Control Letters*, 57, 378-385, 2008.

- [19] P. Naghshtabrizi, J. Hespanha and A.R. Teel. Stability of delay impulsive systems with application to networked control systems. *Trans. of the Inst. of Measurement and Control, Special Issue on Hybrid and Switched Systems*, 32(5), 511-528, 2010.
- [20] D. Nesic and A.R. Teel. Input-output stability properties of networked control systems. *IEEE Transactions on Automatic Control*, 49(10), 1650-1667, 2004.
- [21] P. Park, J. Ko and C. Jeong. Reciprocally convex approach to stability of systems with time-varying delays. *Automatica*, 47, 235-238, 2011.
- [22] A. Seuret. A novel stability analysis of linear systems under asynchronous samplings. *Automatica*, 48, 177-182, 2012.
- [23] G.C. Walsh, H. Ye and L.G. Bushnell. Stability analysis of networked control systems. *IEEE Control Systems Technology*, 10, 438-446, 2002.