



HAL
open science

A FIRST APPROACH FOR RAPID COPYING OF FREE-FORM SURFACES IN 5-AXIS MACHINING

Pierre Breteau, François Thiébaud, Pierre Bourdet, Claire Lartigue

► **To cite this version:**

Pierre Breteau, François Thiébaud, Pierre Bourdet, Claire Lartigue. A FIRST APPROACH FOR RAPID COPYING OF FREE-FORM SURFACES IN 5-AXIS MACHINING. Conference on Integrated Design and Manufacturing in Mechanical Engineering (IDMME), May 2006, Grenoble, France. hal-01226738

HAL Id: hal-01226738

<https://hal.science/hal-01226738>

Submitted on 10 Nov 2015

HAL is a multi-disciplinary open access archive for the deposit and dissemination of scientific research documents, whether they are published or not. The documents may come from teaching and research institutions in France or abroad, or from public or private research centers.

L'archive ouverte pluridisciplinaire **HAL**, est destinée au dépôt et à la diffusion de documents scientifiques de niveau recherche, publiés ou non, émanant des établissements d'enseignement et de recherche français ou étrangers, des laboratoires publics ou privés.

A FIRST APPROACH FOR RAPID COPYING OF FREE-FORM SURFACES IN 5-AXIS MACHINING

Pierre Breteau,

ENS de Cachan,

François Thiébaud,

IUT de Cachan, Université Paris-Sud 11,

Pierre Bourdet,

ENS de Cachan,

Claire Lartigue,

IUT de Cachan, Université Paris-Sud 11,

Laboratoire Universitaire de Recherche en Production Automatisée

Ecole Normale Supérieure de Cachan, 61 av. du Pt Wilson,

94235 Cachan cedex – France, Tel : +33 1 47 40 22 15 – fax : +33 1 47 40 22 20,

e-mail : name@lurpa.ens-cachan.fr

Abstract:

The paper deals with the various steps of free-form copying from surface acquisition to machining using 5 « positioned » axes. The originality of the proposed approach is to be free from surface reconstruction.

The object surface acquisition is performed using an optical digitizing system in order to obtain a representative image of the real surface. Relative positions and orientations sensor/surface are chosen to guarantee the completeness of the digitized points as regards the whole object surface. The next step concerns the pre-processing of the points. Indeed, the data are discrete, non homogeneous, dense and noisy. Cleaning, filtering and densification are essential steps. A voxel representation of the data is carried out with the objective to recreate “pseudo-continuity”. Therefore, the calculation of local characteristics such as local normal to the discrete data is thus possible. The last step is the choice of optimal part set-ups for the machining using 5 positioned axes. To initialize the automatic research of the best set-up, each relative orientation sensor/surface may define one set-up. For each set-up, the trajectory of the ball-en cutter tool is calculated in 3 axes, using the offset inverse method. The feasibility of the whole approach is illustrated through an example

Key words: Surface machining, digitized data, 5-positioned axis machining, voxel representation

1 Introduction

Rapid copying of complex-shaped parts is the process that consists in directly machine data points collected from the measurement of a physical model. More generally, existing methods to reproduce objects with free-form surfaces are made up of the two independent steps [1]: (1) surface reconstruction from the acquired data points; and (2) tool path generation using the constructed surface model. The first step, also well-known as Reverse Engineering, includes preliminary steps such as data pre-processing, data segmentation and data fitting. It is generally time consuming and strongly linked to the possibilities offered by the CAD system used. The resulting surface model is thus an approximation, more or less correct, of the digitized point cloud. The second step, which is performed independently,

relies on a CAM system. Henceforth, tool path generation using a CAM system is an activity well-controlled, offering numerous possibilities in 3-axis machining as well as in 5-axis machining. However, the calculated tool path is also an approximation of the CAD model [2]. The combined procedure suffers from error accumulation and inefficiency [1].

In this context, direct copying, that means directly calculating the tool path from the discrete data points, appears to be an interesting way to explore. Indeed, the step of surface reconstruction is removed, limiting approximation errors and time consuming. Nevertheless, few works propose direct tool path generation from data points. The main reasons are linked to the discrete nature of the data, the lack of data structure and the data quality. This point will be discussed in the next section. Furthermore, few approaches address the problem of 5-positioned axis machining. For each part set-up, the portion of surface accessible by the tool (most generally a ball-end cutter tool) is machined according to a 3-axis strategy. The issue here is to find the minimal number of set-ups allowing the whole surface to be machined.

This paper proposes a method for rapid copying of complex shape part in 5-positioned axis machining. The approach deals with the whole process of free-form copying, from the surface measurement to the actual machining of the surface (figure 1). The surface measurement is performed using an optical digitizing system: a CMM equipped with a laser plane sensor mounted on a PH10 head from Renishaw giving the sensor a large surface accessibility. In this first approach, the scan planning is not automated. Nevertheless, relative positions and orientations sensor/surface are chosen to guarantee the completeness of the digitized points as regards the whole object surface. As the data obtained are discrete, non homogeneous, dense and noisy, operations such as cleaning, filtering and densification are essential steps. For this purpose, a voxel representation of the data is carried out with also the objective to recreate "pseudo-continuity". Therefore, the calculation of local characteristics such as voxel normal and barycentre is thus possible. The last step is the choice of optimal part set-ups for the machining using 5 positioned axes. This is performed by examining for each voxel its accessibility by the tool for a given set-up. An approach is proposed to optimize the number of set-ups allowing the part to be completely machined. Note that, for each set-up, the trajectory of the ball-en cutter tool is calculated in 3 axes, using the offset inverse method.

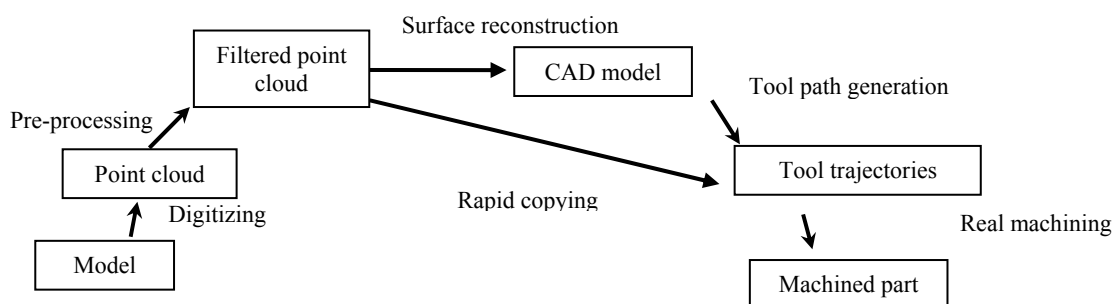

Figure 1. Free-form copying process.

The paper is organised as follows. Section 2 exposed the different stages of tool path generation and describes existing methods to generate tool path from discrete data. Section 3 deals with the digitizing and the data pre-processing based on a voxel representation. Then, section 4 details the method leading to optimised tool set-ups necessary to mill the part. Finally, section 5 is dedicated to an illustration of the whole process through an example. The paper is ended by some conclusions.

2 Tool path generation from discrete data

The tool-path generation consists in the calculation of a set of successive points (figure 2). Basically, for 3-axis machining using a ball-end cutter tool, the calculation relies on the surface geometry, the tool geometry and the machining strategy. The machining strategy defines the driving direction of the tool and the CAM parameters. Common calculation methods consist of three main steps [2]:

- Calculation of the tool location on the surface
- Calculation of a single path in the driving direction according to the machining tolerance
- Calculation of adjacent single paths in the perpendicular direction according to the transversal step.

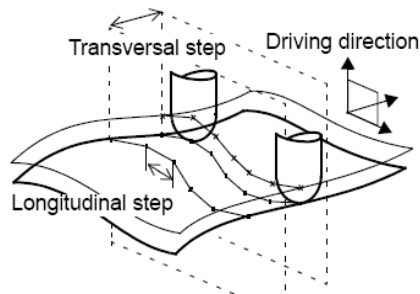

Figure 2. Tool path generation

Although various approaches exist and are efficient when the surface geometry is defined through a CAD model, few methods are proposed in literature when the surface geometry results from a measurement. Obviously, the main problem is the lack of continuity and structure of the data making difficult the calculation of differential geometry properties. The normal for instance is necessary to position the tool onto the surface [2]. Besides, classical parameters, the machining tolerance and the scallop height, defining the level of approximation between the CAD model and the tool path have less sense in such a case. More generally, the machining strategy retained is the usual parallel plane method, the size of the grid giving the level of precision. Nevertheless, different approaches for tool path generation from discrete data have been developed.

Lin and Liu [3] create a rectangular mesh from the digitizing lines obtained with contact or non-contact measuring devices. The rectangular mesh is oriented according to the driving measuring direction, and is the support for tool path generation. Hence, classical methods based on surface meshing can be used. This approach has the advantage to be close to classical methods. On the opposite, a mesh of the data involves a new approximation of the points which is not satisfactory. Indeed, it is difficult to create a mesh from massive point clouds, generally noisy and inhomogeneous. Park and Chung [4] based their approach on the digitising lines obtained with a laser plane sensor. The tool trajectories are directly built on the digitising lines. When different views are superposed, the difficulty is to define what a digitising line is. So this method fails when the object surface requires more than one scan path. Feng and Teng [1] present a method to generate tool path for which machining error and surface finish are explicitly considered. They base their approach on the definition of a CL-net (Cutter Location net) which consists in 2D cells sequentially organised. The size of the cell net is defined relatively to the machining tolerance (for its length) and the maximum scallop height allowed (for its side size). Each cell node corresponds to a CL point. Due to the

absence of continuity, authors evaluate machining errors based on two adjacent tool swept surfaces of the ball-end cutter tool. An optimization method of the position of the cell node is thus proposed to minimize the machining error. This method seems efficient but requires solving an optimization problem. Steps are numerous and difficult to implement.

The method developed by Osty et al [5] can work whatever the nature of the point cloud (figure 3). If z is the tool axis, a grid in the xy -plane is built so that each grid node represents a cutter location. The organisation of the grid defines the machining strategy. When using a parallel plane strategy, the y -direction may define the driving direction and thus the x -axis corresponds to the perpendicular direction. The sampling in both directions gives the level of precision in both directions.

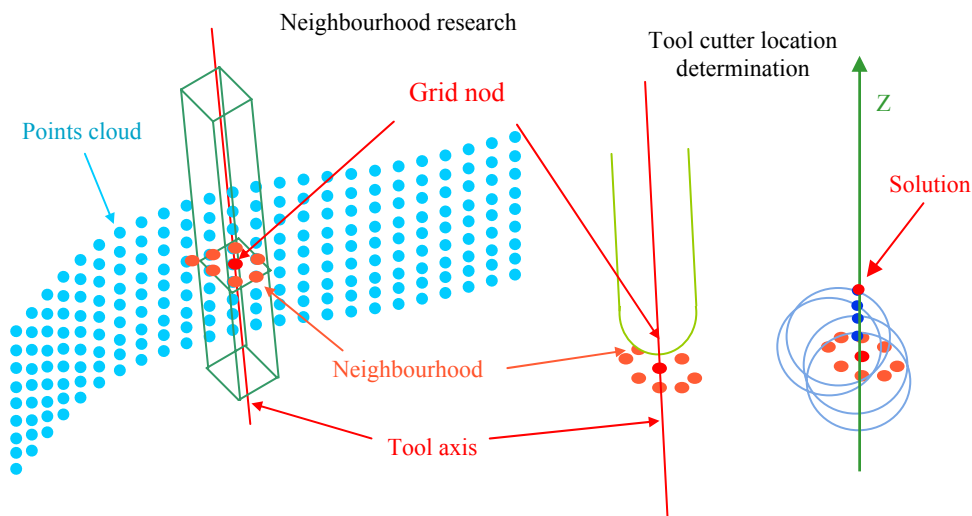

Figure 3. Tool cutter location on discrete data

Authors determine the z cutter locations using a method similar to the offset inverse method. They search points in the neighbourhood of the tool axis the location of which is defined by the grid node. Then, for each point belonging to the neighbourhood, authors calculate the z intersection between the tool axis and the spheres, the radius of which is equal to the tool radius, centred on each point. The CL point is defined by the maximal z value (figure 3). As the grid parameter is fixed, the final result is not optimized as regards the part quality. Indeed, to avoid facets onto the machined surface, the grid parameter is determined in function of the most discriminating part of the point cloud (in the point of view of the chordal deviation). This may involve over-quality for other portions of the surface. The use of an adaptive grid should optimise the method. On the other hand, this method is simple to implement.

We base our approach of direct copying in 5-positioned axis machining on the method proposed by Osty *et al* for 3-axis tool path generation from discrete data points using a ball-end cutter tool. As for most methods, the step of data pre-processing is required. This point is discussed in the next section.

3 Digitizing and data pre-processing

The proposed approach relies on digitized points resulting from 3D measurement of object surfaces. The measuring system used is a Coordinate Measuring Machine (CMM) equipped

with a laser-plane sensor mounted on a motorized indexed head. The sensor is moved in translation according the CMM axes, and the indexed head gives the sensor two additional possibilities of rotations. With such a configuration, each fixed orientation (given by the two rotation angles) defines a sensor setting relatively to the object surfaces. For each setting, the sensor is moved according to a certain direction and with several paths. To ensure the complete sweeping of the object surfaces, different settings are required. As a result, data acquired are dense, non homogeneous and noisy (the noise varying for each digitized point in function of the sensor setting) [6].

To work efficiently, direct copying requires a structure of the data, in order to reduce the amount of data to be treated, to clean the data (filter) and to give data a pseudo-continuity allowing various calculations. For this purpose, our approach is based on a voxel representation.

3.1 Voxel spaces

The voxel representation consists in cutting the volume including the point cloud into small cubes. Each voxel is thus classified in two classes: empty voxels and non-empty voxels. Each non-empty voxel contains a minimum number of digitized points from which voxel attributes are calculated. The most usual voxel attributes are the barycentre, the normal and the quality indicators. The latter quantifies the point cloud quality which is essential for direct copying [7].

For this specific application the following three quality indicators are relevant: the completeness, the noise and the density. Indeed, the point cloud must be complete free from digitizing gaps in particular for CL point calculation. The noise is also an important factor as it directly influences the normal calculation. To ensure that the normal calculation is efficient, the noise must be as small as possible. Digitizing with laser-plane sensors implies that the density of acquired points is not homogeneous: density is more important for digitizing lines than in other directions. Besides, over-lapping zones exist resulting from the various paths for a given setting. Previous works highlighted that the density must be homogeneous for a good surface finish.

In the next, we consider that a preliminary analysis of the point cloud has been performed, leading to data, complete as regards the actual surface, homogeneous, and with a digitizing noise admissible as regards predefined thresholds.

3.2 Normal calculation

The calculated normal can be interpreted as a local normal, representative of a small portion of the surface (a small sub-set of points). Therefore, the normal is calculated as a voxel attribute. The size of an elementary cube is fixed in function of the free form surface geometry and the dimension of the tool radius used for the milling. The main constraint is linked to the tool radius which gives a superior limit to the voxel size: the size is smaller than the tool radius. If the majority of the surfaces are tensed surfaces, the normal direction does not change abruptly. As a result, the voxel size can be large. At the opposite, when the normal direction bluntly changes the size of the voxel must be small in order to account for abrupt changes of normal directions.

The normal is calculated as the normal to the least square plane that best fits the points including in the voxel. This method works well as long as the point number is sufficient to calculate the normal. When locating close to the point cloud frontier, a voxel may only

contain one or two points which are not enough for plane association. In this case, the normal is calculated using the voxel and its 27 neighbours. Indeed, the voxel representation allows a rapid identification of a voxel neighbours. If a voxel is identified using the 3 indices (i, j, k), voxels neighbours are found by combining i, i-1, i+1 with k, k-1, k+1, and j, j-1, j+1. Once the voxel neighbours are identified, each voxel barycentre can be calculated. The normal thus corresponds to the normal to the plane that best fits the set of 27 barycentres.

To minimise the calculation time of the least-square plane, the method used is that of Shakarji [8] which leads to the exact solution of the plane. If pts is the matrix defining the collection of the n_{pts} points on which the plane is fitted. Pts is a matrix n_{pts} lines and 3 rows:

$$pts = \begin{bmatrix} x_1 & y_1 & z_1 \\ x_2 & y_2 & z_2 \\ \vdots & \vdots & \vdots \\ x_{n_{pts}} & y_{n_{pts}} & z_{n_{pts}} \end{bmatrix}$$

As the sum of the variations is null, the barycentre of the n_{pts} belongs to the least square plane. Then the origin of the n_{pts} coordinate referential is moved to the barycentre. In this configuration, the normal vector of the least square plane is the eigenvector associated to the smallest eigenvalues of the 3×3 matrix defined by $pts^T \times pts$.

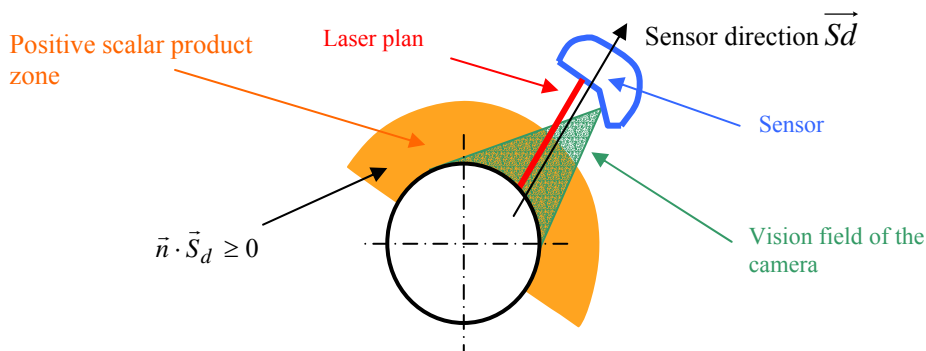

Figure 4. Sensor vision field.

For tool path calculation, the normal must be directed outward material. To correctly orient the normal we take advantages of the knowledge of the sensor orientation \vec{S}_d . If a point is seen by the sensor, the scalar product between the normal at this point and the sensor orientation must be positive (figure 4). Therefore if $\vec{n} \cdot \vec{S}_d \geq 0$, where \vec{n} is the normal at the considered point, then normal orientation is correct, if not the normal orientation is inverted.

At this stage, a couple (normal, barycentre) is affected to each voxel. Therefore, the whole point cloud can be substituted by its voxel representation making simple further steps. It gives data structure, pseudo-continuity and attributes allowing calculations such as accessibility.

4 Point cloud partitioning

Our application lies on free-form copying from surface acquisition to machining using 5 « positioned » axes. The machine tool we use is a five axis milling center “Mikron UCP710”.

In 5-positioned axes, the two rotation axes (A and C) of the milling machine are fixed for a given set-up (figure 5).

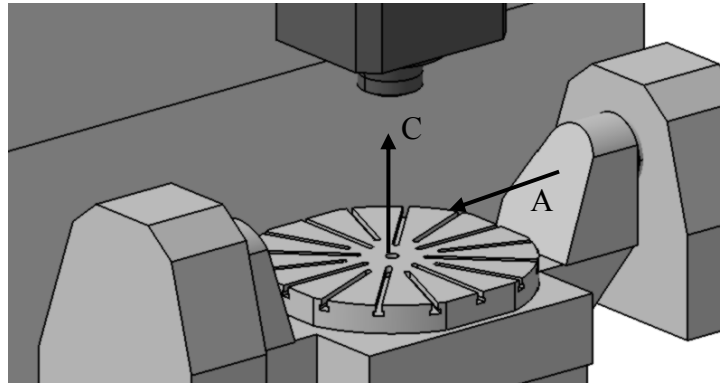

Figure 5. The machine tool axes

The two objectives of the partitioning are to obtain the collection of set-ups that permits to machine the whole part surface and to minimize the number of set-ups. The efficiency of the partitioning lies on the use of the voxel representation and its associated attributes. The proposed two step method consists in searching (1) to find admissible set-ups that allow milling the points which are included in a given voxel and (2) to group voxels according to the admissible set-ups. The first step of the method is called the voxel visibility determination.

According to the tool radius value, some details of the part surfaces can not be machined whatever the set-up (figure 6). Consequently, a second voxel representation is used for which the cube size is equal to the tool radius. The whole study developed in section 4 take advantage of barycentres and normals of the voxels of this second voxel representation.

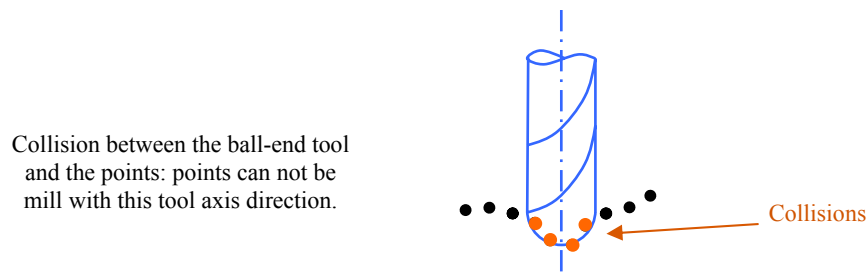

Figure 6. Collisions between the ball-end tool and the point cloud.

For this second voxel representation, the normal is calculated as the average of the normals assigned to the voxels of the first representation that are included within the new sized voxel.

4.1 Admissible set-ups

For a given voxel, a set-up is admissible if the points included in the voxel can be machined. As an approximation, we consider that a set-up is admissible if the least-square plane fitted to the points can be machined. Therefore, a set-up is admissible for a given voxel if the two following conditions are satisfied:

1. The tool axis belongs to the visibility cone built around the normal of the voxel and which vertex is the barycentre of the voxel.
2. There is no collision between the tool and the point cloud.

The goal of the visibility is to determine which set-ups may be admissible for each voxel according to machining criteria. That is called voxel visibility since the tool radius is not taken into account. Further, a voxel could be visible but non-accessible. The machining criteria are linked to the tool geometry and the quality of the machining. For a ball end tool, the contact between the tool and the part may be theoretically allowed all over the extremity of the tool. Practically, vibrations occur when machining close to the tool body. The resulting admissible orientations of the tool relative to the part must be included into the cone presented figure 7 which is called the visibility cone.

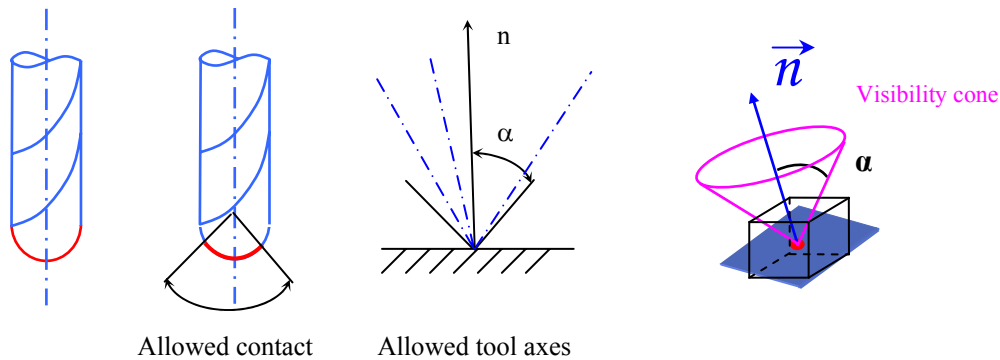

Figure 7. Determination of the visibility cone

For each voxel, the visibility cone is defined by the voxel barycentre which is the cone vertex and the voxel normal which its axis. The angle α defines the cone dimension (figure 7). On the other hand, a domain including all the tool/part orientations attainable by the machine is defined. This domain is called the tool axis domain. Theoretically to determine the tool/part orientations which make it possible to see a voxel, the intersection between the tool axis domain and the visibility cone must be done. In practice, that requires heavy calculations owing to the fact that the tool axis domain includes infinity of tool/part orientations. To simplify calculations, the tool axis domain is sampled.

To sample the tool axis domain, the two angles associated with the two rotation axis of the machine are used. An increment must be correctly chosen for both angles. The forms of the model which is copied influence the choice of the increment value. Indeed, for a model presenting many details accessible with particular tool/part orientations (a statuette of elephant for instance), a small value for the increment must be chosen. For the application developed in section 5 this increment is chosen equal to 15° . Each set-up is referenced thanks to a set-up number.

To determine the voxel visibility, a table is built. The row of this table contains one voxel number followed with the number of each admissible set-up. The table is filled out in the following way. For each set-up, if the tool axis is included within the visibility cone, the set-up reference is store in the table on the voxel row.

The second stage of the determination of admissible set-ups consists in searching for each set-up if there is a collision between the tool body and the voxel barycentres (figure 8). A

collision is detected when some voxel barycentres are included in the volume occupied by the tool. All the set-ups for which a collision is detected are removed from the table.

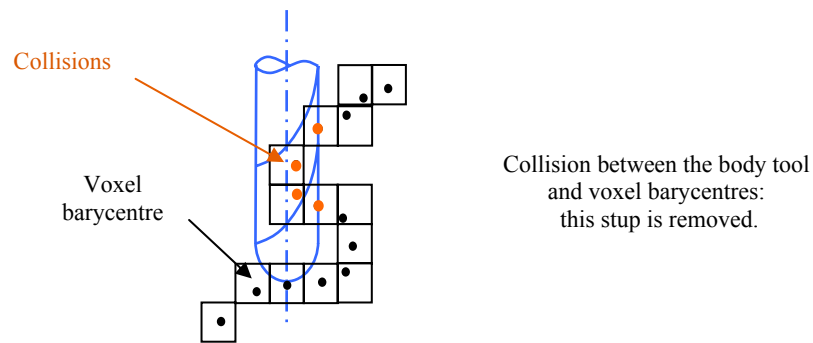

Figure 8. Collisions between the tool and the barycentres.

4.2 Voxel grouping

The result of the previous section consists in a table of the admissible set-up for each voxel. The last step of the partitioning consists in determining the collection of set-ups that permit to machine the entire part. The best partitioning is obtained while respecting the following constraints:

- the number of set-ups is minimal,
- the machined area for a given set-up is larger as possible,
- the number of small machined zones for a given set-up is smaller as possible.

The partitioning is performed through voxel grouping. Three methods are proposed to achieve the voxel grouping.

The first one consists in searching which set-up permits the machining of the maximum number of voxels. This method implemented by Germain [9] gives results when the part surface is tensed. If the surface is not tensed, the set-up that corresponds to the grouping of the maximum of admissible voxels may correspond to a large number of small machined zones which is not acceptable.

The second method consists in using a growing method. This method is initialised by choosing an initial group composed of a unique voxel and its associated admissible set-ups. Each non-empty voxel of the neighbourhood of the group is added to the group while a common admissible set-up exists. This method that depends of the initial voxel has not yet been implemented.

The third method consists in manually imposing set-ups. This method permits to group voxels for set-ups that seem obvious to the operator according to the shape of the part. The advantage of this third method is to drastically decrease the amount of calculation. This third method should advantageously be used as an initialisation method of the two other methods.

For each one of the three methods, voxels that are machined for a retained set-up are removed and the method is applied to the remaining voxels.

5 Application

In order to validate the efficiency of the proposed approach, its application is performed to the rapid copying of a little statue representing a cartoon character.

The first step is the object measurement. The scanning of the object is realised thanks to a laser plane sensor mounted on a CMM equipped with a laser plane sensor mounted on a PH10 head from Renishaw. The relative positions and orientations of the sensor relative to the surface are chosen to guarantee the completeness of the digitized points as regards the whole object surface. To obtain a complete point cloud, five sensor directions have been used; z, x, -x, y, -y. The point cloud resulting from the measurement is dense (221746 points), noisy and inhomogeneous (figure 9.b).

The second step is data pre-processing to substitute the point cloud to its voxel representation with attributes. The size of each cube is chosen equal to 2mm, which leads to 1437 voxels. The normal and barycentre are thus calculated for each voxel (figure 9.c).

The third step consists in the set-up determination, we take advantage of the knowledge of the 5 sensor/surface settings used to digitize the object surfaces. As presented in section 4.2, the five sensor/surface settings are imposed as tool/surface settings. Therefore, for each voxel, the accessibility by one of the 5 measuring directions is tested. The tests prove that the five imposed set-ups allow the surface to be entirely machined. The machine angle values that correspond to the 5 orientations are obtained: $(A=0, C=0)$, $(A=90, C=-90)$, $(A=90, C=90)$, $(A=90, C=180)$, $(A=90, C=0)$.

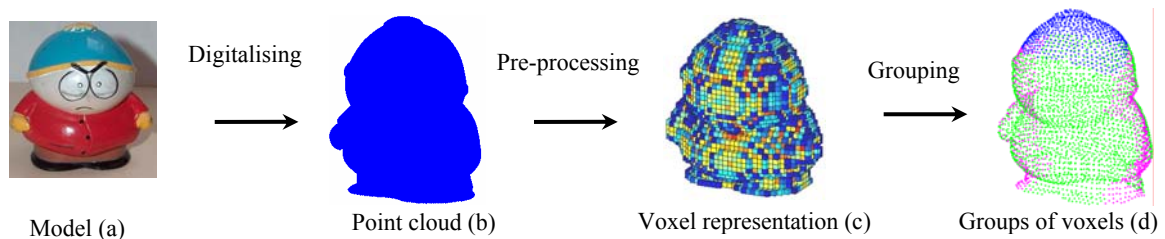

Figure 9. Pre-processing and voxel grouping

The groups of voxels are now defined for each set-up and the tool paths can be generated. The base of the algorithm developed for the tool-path calculation is the one developed by Osty and presented in section 2. In this method, the coordinates (x,y) of the successive CL points correspond to the nod coordinates on a rectangular grid.

Concerning the method we propose and for each set-up, the tool-path is calculated as follow:

- a plane, normal to the tool axis, is created (figure 10). Let us call (x_p, y_p) the coordinates of a point that belongs to this plane,
- the projection of all the voxel vertex that belong to the selected set-up is performed and a envelope rectangular grid is created (figure 10).
- the order the nods are selectioned from the grid is defined through the choice of the machining strategy,
- for each nod, if the tool axis intersects the group of voxels, the CL point is calculated,

- the successive CL points are collected that gives the tool-path (figure 10).

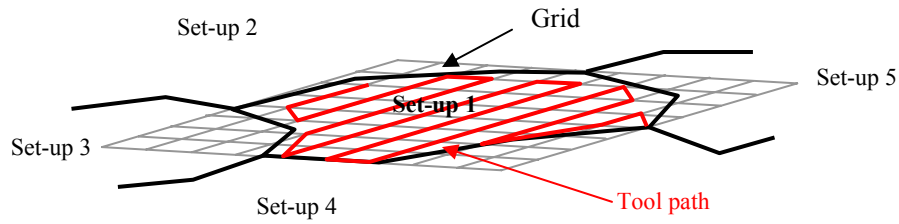

Figure 10. Machining zone.

Once tool paths are generated in 3-axis machining for each set-up, virtual machining is performed in order to check the calculated tool-paths using the module of simulation of CATIA V5[®]. The purpose of this virtual machining is to check that the tool-paths are free from collision with external systems. It also allows validating the machining covering of the whole surface using the different tool set-ups.

At final, the surface machining is carried out on the machine MIKRON UCP 710. A phase of roughing must be added in order to make operant the finishing phase. The method proposed by Lin [3] has been developed by Blat [10] and adapted by Breteau [11] to take into account the specificities of high speed machining.

Figure shows the result of the milling, which includes both phases, roughing and finishing using the 5 set-ups. Due to the limit of the tool radius, some surfaces can not be milled such as the neck of the little character. Nevertheless, some details like the eyes or the wind-breaker buttons are visible which brings out the efficiency of this approach.

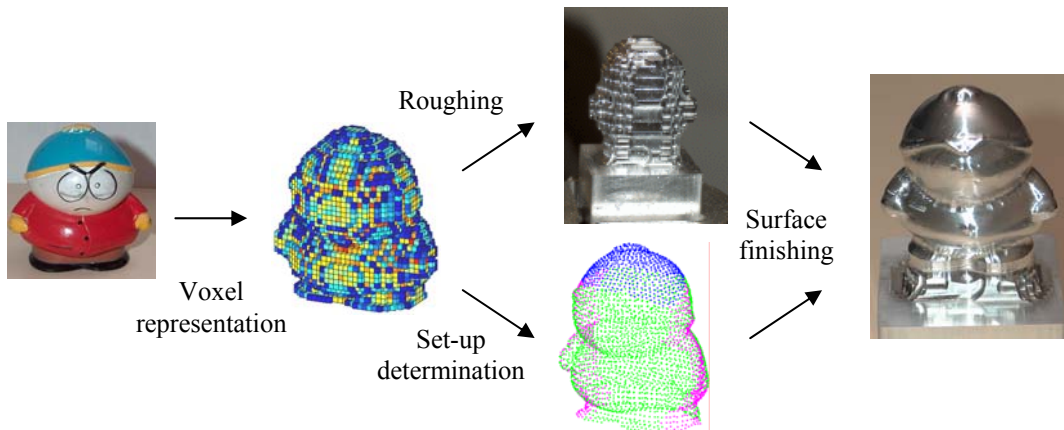

Figure 11. Copy of the part.

6 Conclusion

In this paper, various steps of free-form copying from surface acquisition to machining using 5 « positioned » axes have been presented.

First step concerns the pre-processing of the points. A voxel representation of the data is carried out. The cloud of point is certified as acceptable for the copying since the completeness, the noise and the density indicators are within acceptable ranges. Therefore, the calculation of local characteristics such as local normal to the discrete data is performed. The last step is the choice of optimal part set-ups for the machining using 5 positioned axes. A visibility cone and a collision research method are presented that permits to define the admissible set-ups for each voxel. The research of the retained set-ups for machining is performed while grouping voxels. Three methods are proposed to group the voxels.

The whole method has been developed and tested using the model Cartman[®]. The relative orientations sensor/surface define initial set-ups. For all voxels, at least one of the initial set-ups belongs to the admissible set-ups. So, voxel grouping is performed using these initial set-ups. For each retained set-up, the tool-path of the ball-end cutter tool is calculated in 5 “positioned” axes machining, using the offset inverse method. The copying of the part has been performed on a 5 axis milling centre that proves the feasibility of the whole method.

Improvements, in particular those concerning automated scan planning and tool path generation algorithms are in progress.

References

- [1] H-Y. FENG, Z. TENG, *Iso-planar piecewise linear NC tool path generation from discrete measured data points*, Computer-Aided Design, N°37, 2005, pp. 55-64.
- [2] E. DUC, C. LARTIGUE, *Algorithms for the evaluation of errors in the calculation of the NC tool paths*, 2nd International Seminar on Improving Machine Tool Performance, La Baule (France), CDRom paper 20 pages, July. 2000
- [3] A-C. LIN, H-T LIU, *Automatic generation of NC cutter path from massive data points*, Computer-Aided Design, N°30, 1998, pp. 77-90.
- [4] S-C. PARK, Y-C. CHUNG, *Tool-path generation from measured data*, Computer-Aided Design, N°35, 2003, pp. 467-475.
- [5] G. OSTY, A. CONTRI, E. DUC, *Free-form copying from point clouds; A tool-path calculation method using B-Spline interpolation*, RCFAO, Rapid production, 2000, pp. 367-382.
- [6] G. OSTY, *Extraction de particularités sur données discrètes issues de numérisation 3D : Partitionnement de grand nuage de points*, PhD. Thesis, ENS de Cachan, January 2001.
- [7] A. CONTRI, P. BOURDET, C. LARTIGUE, *Quality of 3D digitised points obtained with non-contact optical sensors*, Annals of the CIRP, 51(1), 2002
- [8] C-M. SHAKARJI, *Least-Squares Fitting Algorithms of the NIST Algorithm Testing System*, Journal of Research of the National Institute of Standards and Technology, Vol. 103, 1998, pp. 633-641.
- [9] F. GERMAIN, *Contribution à l'usinage direct d'un nuage de points : Partitionnement par visibilité et accessibilité*, DEA de Production Automatisée, ENS de Cachan, July 2004.
- [10] B. BLAT, *Numérisation et copiage de formes complexes*, DEA de Production Automatisée, ENS de Cachan, July 1999.
- [11] P. BRETEAU, *Copie de forme par usinage cinq axes positionnés; usinage direct d'un nuage de points*, Mémoire de Master, ENS de Cachan, 2005