



HAL
open science

Cross Layer Rate Control, Medium Access Control and Routing Design in Cooperative Multi-Hop Wireless Networks

Liang Zhou, Baoyu Zheng, Jingwu Cui, Benoit Geller, Anne Wei, Shan Xu

► **To cite this version:**

Liang Zhou, Baoyu Zheng, Jingwu Cui, Benoit Geller, Anne Wei, et al.. Cross Layer Rate Control, Medium Access Control and Routing Design in Cooperative Multi-Hop Wireless Networks. 9th International Conference on Intelligent Transport Systems Telecommunications,(ITST), 2009 , 2009, Lille, France. 10.1109/ITST.2009.5399303 . hal-01225698

HAL Id: hal-01225698

<https://hal.science/hal-01225698>

Submitted on 4 Dec 2015

HAL is a multi-disciplinary open access archive for the deposit and dissemination of scientific research documents, whether they are published or not. The documents may come from teaching and research institutions in France or abroad, or from public or private research centers.

L'archive ouverte pluridisciplinaire **HAL**, est destinée au dépôt et à la diffusion de documents scientifiques de niveau recherche, publiés ou non, émanant des établissements d'enseignement et de recherche français ou étrangers, des laboratoires publics ou privés.

Cross Layer Rate Control, Medium Access Control and Routing Design in Cooperative Multi-Hop Wireless Networks

Liang Zhou, Baoyu Zheng, Jingwu Cui, Benoît Geller, Anne Wei, Shan Xu

Abstract

In this paper, we address the rate control, the medium access control (MAC) and the routing problem for cooperative multi-hop wireless networks (MHWN) in the framework of the utility function maximization. Compared to its counterpart in traditional wireless network, control method in the cooperative wireless network is much more complex, which is due to the constraints arising from the cooperation among the users and the contention for the wireless channel access. At first, we construct a general mathematics model for the cooperative MHWN. And then, we develop a cross-layer solution which consists of the link capacity detection by adjusting persistence probability at the MAC layer, the flow rate control by achieving the maximal utility at the transport layer and the optimal routing at the network layer. This proposal is designed in distributed manner in order to support a simple and efficient implementation for MHWN. Finally, fairness issue for the cooperative network is presented to improve the practical performance of the proposed solution. The simulation results show the effectiveness of the proposed solution for the cooperative network.

Index Terms

cooperative; wireless network; multi-hop; medium access control; rate control; routing

L.Zhou, B.Y.Zheng, J.W.Cui and S. Xu are with the Electrical Engineering Department, Shanghai Jiao Tong University, Shanghai, China and the Institute of Signal Processing and Transmission, Nanjing University of Posts and Telecommunications, Nanjing, China; B. Geller and A.Weï are with the Laboratory of SATIE, Ecole Normale Supérieure de Cachan, Paris, France
E-mail:zking@sjtu.edu.cn (Liang Zhou)

I. INTRODUCTION

In a wireless cooperative communication system, each user is assumed to transmit data and act as a cooperative agent for another user. That is to say, each user transmits both its own bits as well as some information for its partner [1]. The idea of cooperative network is first proposed to handle “flash crowds” on the Internet, where end-hosts cooperate in order to improve the overall network performance [2]. In recent years, some cooperative strategies for content delivery and sharing in wireless network have been proposed [3-5]. However, most of research in this area is to optimize physical layer performance without considering much detail about how cooperation interacts with higher layers and improves network performance. Specially, there is no specific solution describing how to solve the data flow movement problem over multiple hops in this architecture. In fact, since the cooperative network is a classic multi-source-multi-path system, one of the most challenge issues is the flow rate control: the Internet is based on an end-to-end paradigm, where the transport protocol (e.g. TCP) instances at the endpoints to detect overload conditions at intermediate nodes. When congestion occurs, the source reduces flow rate [6]. However, cooperative network is usually a distributed dynamic system and the congested nodes might not be adjusted at all when the sources react to the congestion.

In this paper, we jointly formulate the rate control, medium access control and routing problem for cooperative multi-hop wireless networks (MHWN), and it is designed in distributed manner in order to support a simple and efficient implementation for MHWN. The fundamental purpose is to decompose the utility function into a flow control problem which determines the total source rate, and a division problem which describes how to split the total rate among a set of least congested paths according to the link persistence probability. The main contributions of this research are showed as follows: Firstly, we construct a general multi-source-multi-path model for this cooperative MHWN. Secondly, we develop a cross-layer solution which consists of the link capacity detection by adjusting persistence probability at the MAC layer, the flow rate control by achieving the maximal utility function value at the transport layer and the optimal routing at the network layer. The realization of joint rate control, MAC control and routing for the specific cooperative MHWN system is the highlight of this paper. Finally, fairness issue for the cooperative network is presented to improve the practical performance of the proposed solution.

The remainder of this paper is organized as follows. Section II constructs a general mathematics model for the cooperative MHWN. Based on the problem analysis, a joint optimal rate control, medium access control and routing algorithm is proposed in Section III. In Section IV, we present numerical results using the proposed algorithm, followed by the concluding remarks in Section V.

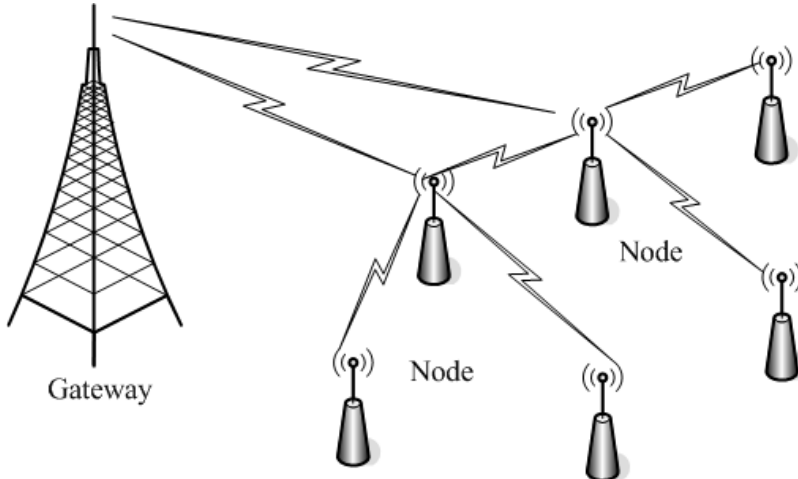

Fig. 1. The topology structure of the distributed cooperative MHW network.

II. SYSTEM MODEL

The system consists of a set of N nodes with same computation and transmission capabilities, communicating through bidirectional wireless links between each other. There are wireless gateways providing access to the other networks (i.e., Internet), and the system architecture is composed of such two kinds of communications as Node-to-Gateway and Node-to-Node, as shown in Fig.1. The characteristics of the wireless cooperative architecture and its differences with the traditional always-connected model motivate the need to revisit the design of the protocols designed for wired infrastructure. In this paper, we employ the cooperative protocol introduced in [7], which designs a network-wide broadcasting protocol that exploits cooperative diversity and addresses the challenges of: (a) enabling cooperation and (b) exploiting the diversity benefits due to cooperation.

Consider this wireless network whose links are denoted by $\mathbf{L} = \{1, 2, \dots, L\}$. Let c_l be the capacity of link $l \in \mathbf{L}$ and $\mathbf{c} = [c_1, c_2, \dots, c_L]^T$. Let $\mathbf{S} = \{1, 2, \dots, S\}$ be the set of sources. Each source s has n_s potential available paths from the source to the destination. Let the $L \times 1$ vector $\mathbf{R}_{s,i}$ denotes the set of links used by source $s \in \mathbf{S}$ on its path $i \in \{1, 2, \dots, n_s\}$, whose l th element equals to 1 if path contains link l and 0 otherwise, and $N_{s,i}$ denotes the number of links on the path i . The set of all the available paths of user s is defined by

$$\mathbf{R}_s = [\mathbf{R}_{s,1}, \mathbf{R}_{s,2}, \dots, \mathbf{R}_{s,n_s}] \quad (1)$$

and the total paths in the network are defined by a routing matrix \mathbf{R} ,

$$\mathbf{R} = [\mathbf{R}_1, \mathbf{R}_2, \dots, \mathbf{R}_S] \quad (2)$$

For each source s , let $x_{s,i}$ be the rate of source s on path $\mathbf{R}_{s,i}$, and $x_s = \sum_{i=1}^{n_s} x_{s,i}$ be the total source rate. Let $m_s \geq 0$ and $M_s \leq \infty$ be the minimum and maximum rates, respectively, i.e., $m_s \leq x_s \leq M_s$. When each source s transmits at a total rate of x_s , it attains a utility $U_s(x_s)$. We assume that $U_s: \mathfrak{R}_+ \rightarrow \mathfrak{R}$ is continuous, increasing and strictly concave. Let

$$x = [x_{1,1}, \dots, x_{1,n_1}, x_{2,1}, \dots, x_{2,n_2}, \dots, x_{n,1}, \dots, x_{n,n_s}]^T \in \mathfrak{R}_+^R \quad (3)$$

be the vector of all path rates of all sources. Our objective is to choose rates x so as to maximize the total utility $\sum_{s \in \mathcal{S}} U_s(x_s)$:

$$\begin{aligned} & \max_{x_s \geq 0} && \sum_{s \in \mathcal{S}} U_s(x_s) && (4) \\ & \text{subject to} && x_s \leq \sum_{i=1}^{n_s} x_{s,i}, \\ & && \mathbf{R}x \leq c \\ & && x_{s,i} \geq 0, m_s \leq x_s \leq M_s \end{aligned}$$

However, in the cooperative system, each node and each link has a contention resolution protocol based on the transmission persistence probability. Let $L_{out}(s)$ denotes the set of outgoing links from node $s \in \mathcal{S}$, $N_{to}^I(l)$ as the set of nodes whose transmissions cause interference to the receiver of link l , excluding the transmitter node of link, and $L_{from}^I(s)$ as the set of links whose transmissions get interfered from the transmission of node s , excluding the outgoing links from node s . Therefore, if the transmitter of link l and a node in $N_{to}^I(l)$ transmit data simultaneously, the transmission of link l fails. If node s and the transmitter of a link l in $L_{from}^I(s)$ transmit data simultaneously, the transmission of link l also fails. Assuming each node s transmits data with a probability p'_s , when it determines to transit data, it chooses one of its outgoing paths with a probability q_l , $l \in L_{out}(s)$. Consequently, link $l \in L_{out}(s)$ transmits data with a probability $p_l = p'_s q_l$, which is called persistence probability of link l . Therefore, the data rate on path i , $x_{s,i}$, is obtained as minimum rate of link in the path:

$$x_{s,i}(P_s) = \min_{l \in [1, N_{s,i}]} c_l p_l \prod_{k \in N_{to}^I(l)} (1 - \sum_{m \in L_{out}(k)} p_m) \quad (5)$$

where $P_s = [p_1, \dots, p_{N_{s,i}}]$, $P = [P_1, P_2, \dots, P_S]$.

With the above analysis, we can specify the cooperative wireless networks utility maximization with “contention” link:

$$\begin{aligned}
 & \max_{x_s \geq 0} && \sum_{s \in \mathcal{S}} U_s(x_s) && (6) \\
 & \text{subject to} && x_s \leq \sum_{i=1}^{n_s} x_{s,i}(P_s) \\
 & && \mathbf{R}x \leq c \\
 & && x_{s,i} \geq 0, m_s \leq x_s \leq M_s, 0 \leq P \leq 1
 \end{aligned}$$

III. JOINT OPTIMAL CONTROL ALGORITHM

In this section, we present a Joint Optimal Control (JOC) algorithm to jointly optimize rate control, medium access control and routing for the aforementioned cooperative wireless networks based on the cross-layer design.

A. JOC Algorithm

In the case of multi-path flow control problem, many literatures have been proposed by introducing the variable of path price to maximum the total utility function of the system [8-10]. In [9], the author solves the optimal congestion control problem by taking the path price into consideration, and the optimal source rate x_s^* is given by

$$x_s^* = \sum_{R_{s,i}^* \in R_s^*} x_{s,i}^* = \left[U'_s(p_s^{r*}) \right]_{m_s}^{M_s}, \quad \text{and} \quad x_{s,i} = 0 \quad \text{if} \quad p_{s,i}^r > p_s^{r*}$$

where $[z]_{m_s}^{M_s} = \max(m_s, \min(M_s, z))$, $p_{s,i}^r$ is the path price, p_s^{r*} is the minimum path price among R_s , path $R_{s,i}^*$ has the minimum path price $p_{s,i}^{r*} = p_s^{r*}$, and R_s^* defines the set of all minimum price paths $R_{s,i}^*$ of source s . The above equation suggests a way to adapt the total source rate to congestion, but it does not specify how to distribute the total rate among the available paths. A naive approach is to simply split it evenly along paths that have the least current price. This algorithm, however, does not converge, e.g. when multiple paths have different path prices. In the cooperative wireless system, we can view the persistence probability as a special path price, the distributed optimal x_s at each source can be adjusted according to the persistence probability of each link. Similarly, the persistence probability can also be adjusted according to current x_s . Intuitively, the expected result will allocate the “right” amount persistence probability to the “right” links to alleviate the congestion, which may then induce an increase in end-to-end throughput of the whole system. Therefore, we need to find an algorithm that distributively

and adaptively control the flow rate, persistence probability and routing from the link and source aspects, respectively.

JOC Algorithm: We assume that time is slotted, and the links are fixed within a time slot but independently change between different slots. During each time slot t , the following three units are carried out simultaneously until convergence.

- **MAC:** Each link l receives flow rates $x_{s,i}(t)$ for all paths $\mathbf{R}_{s,i}$ that contain link l , and computes a new persistence probability

$$p_l(t+1) = \left[p_l(t) + \kappa \frac{c_l - \sum_s \mathbf{R}_{s,i} x_{s,i}(t)}{p_l(t)} - \kappa \frac{\sum_{k \in L_{from}^l(t)} \varepsilon_k}{1 - \sum_{m \in L_{out}(t_l)} p_m} \right]_0^1 \quad (7)$$

t_l is the transmitter node whose path contains link l , $\kappa > 0$, and

$$\varepsilon_l = \begin{cases} 0, & \text{if } \sum_s x_{s,i}(t) \leq c_l p_l \prod_{k \in N_{to}^l(t)} (1 - \sum_{m \in L_{out}(k)} p_m) \\ 1, & \text{otherwise} \end{cases}$$

Informing new probability $p_l(t+1)$ to all sources s whose path $\mathbf{R}_{s,i}$ contains link l ; and each source receives $p_{s,i}^r = P_s^T \mathbf{R}_{s,i}$ from the network for all its paths $\mathbf{R}_{s,i}$, $i = 1, 2, \dots, n_s$ and decides the maximum persistence probability $p_s^{r*} = \max_{i=1,2,\dots,n_s} p_{s,i}^r(t)$.

- **Rate control:** Updates the source rate $x_s(t+1)$:

$$x_s(t+1) = [U'_s(p_s^{r*}(t))]_{m_s}^{M_s} \quad (8)$$

To these paths which do not have the maximum persistence probability, path rate $x_{s,i}(t+1)$ on path $\mathbf{R}_{s,i}$ is:

$$x_{s,i}(t+1) = [x_{s,i}(t) - \gamma(p_s^{r*}(t) - p_{s,i}^r(t))]^+, \gamma > 0 \quad (9)$$

To the path $\mathbf{R}_{s,j}$ that has the maximum persistence probability, we set its rate as:

$$x_{s,j}(t+1) = [x_s(t+1) - \sum_{i \in [1, n_s], i \neq j} x_{s,i}(t+1)]^+ \quad (10)$$

and then informs all the new flow rate $x_{s,j}(t+1)$ to links l contained in path $\mathbf{R}_{s,i}$.

- **Routing:** Over the chosen link, sending an amount of bits to destination according to the rate determined by the rate control unit.

Note that, the persistence probability of the link l depends on two aspects: one is the current flow rate relative to link capacity, while the other one is the current link affected by other users. In the case of path rate, the rates on all paths that have less than the maximum persistence probability are reduced

by an amount proportional to the absent probability, and the rate on the maximum probability path is increased, so that the new rates on all paths sum up to the new total source rate determined in the flow control decision.

B. Performance Evaluation

We first associate Lagrange multiplier for each of the constraints, and use the KKT optimality conditions for optimization [11-12], solving this problem is equivalent to satisfying the complementary slackness condition and finding the stationary points of the Lagrange.

$$\begin{aligned}
L_{sys} &= L(x, P, \bar{\lambda}, \underline{\lambda}) \\
&= \sum_{s \in S} U_s(x_s) - \bar{\lambda}_s(x_s - \sum_{i=1}^{n_s} x_{s,i}(P_s)) - \underline{\lambda}_l^T(\mathbf{R}x - c) \\
&= \left(\sum_{s \in S} U_s(x_s) - \bar{\lambda}_s x_s \right) + \bar{\lambda}_s \sum_{i=1}^{n_s} x_{s,i}(P_s) - \underline{\lambda}_l^T(\mathbf{R}x - c)
\end{aligned} \tag{11}$$

where $\bar{\lambda} = [\bar{\lambda}_1, \bar{\lambda}_2, \dots, \bar{\lambda}_S]$, $\underline{\lambda} = [\lambda_1, \lambda_2, \dots, \lambda_L]^T$. By linearity of the differentiation operator, this can be decomposed into two separate maximization problems

$$\begin{aligned}
\max_{x \geq 0} L_x(x, \bar{\lambda}) &= \sum_{s \in S} U_s(x_s) - \bar{\lambda}_s x_s \\
\max_{P \geq 0} L_P(\bar{\lambda}, \underline{\lambda}, P) &= \bar{\lambda}_s \sum_{i=1}^{n_s} x_{s,i}(P) - \underline{\lambda}_l^T(\mathbf{R}x - c) \\
&= \bar{\lambda}_s \sum_{i=1}^{n_s} \left(\min_{l \in [1, N_{s,i}]} c_l p_l \prod_{k \in N_{to}^I(l)} \left(1 - \sum_{m \in L_{out}(k)} p_m \right) \right) - \underline{\lambda}_l^T p_l (x_l - c_l)
\end{aligned}$$

The first maximization is already implicitly solved by the rate control mechanism for different U_s [13], while the second maximization still need to be solved which aims at allocating exactly the right persistence probability of each link to reduce the congestion at the network bottlenecks. Here, we focus on proving the convergence of the persistence probability problem.

Because $\max L_P(P)$ is a typical non-concave/convex problem, it is difficult to take the derivative of $L_P(P)$ with respect to p_l directly. To get around the difficulty, we take logarithm operator on $L_P(P)$ to get $L_P(\tilde{P})$, that is $L_P(\tilde{P}) = \min_{l \in [1, N_{s,i}]} \sum_{i=1}^{n_s} \log(c_l p_l \prod_{k \in N_{to}^I(l)} (1 - \sum_{m \in L_{out}(k)} p_m)) + \log p_l (x_l - c_l)$, where $\tilde{p}_l = \log p_l$. In appendix I, we will show that the partial Lagrange is a strictly concave function of a

logarithmically transformed probability vector. So we can decompose that

$$\begin{aligned}
L_P(\tilde{P}) &= \min_{l \in [1, N_{s,i}]} \sum_{i=1}^{n_s} \log \left(c_l p_l \prod_{k \in N_{to}^l(l)} \left(1 - \sum_{m \in L_{out}(k)} p_m \right) \right) + \log p_l (x_l - c_l) \\
&= \sum_{i=1}^{n_s} \log \left[c_l p_l \prod_{k \in N_{to}^l(l)} \left(1 - \sum_{m \in L_{out}(k)} p_m \right) - \sum_{n \in L_{from}^l(t_i)} c_n p_n \prod_{k \in N_{to}^l(n), k \neq t_i} \left(1 - \sum_{m \in L_{out}(k)} p_m \right) \right] \\
&\quad + \log p_l \left(c_l - \sum_s \mathbf{R}_{s,i} x \right) \tag{12}
\end{aligned}$$

Assuming

$$\varepsilon_l = \begin{cases} 0, & \sum_s x_{s,i}(t) \leq c_l p_l \prod_{k \in N_{to}^l(l)} \left(1 - \sum_{m \in L_{out}(k)} p_m \right) \\ 1, & \text{otherwise} \end{cases}$$

Taking the derivative of $L_P(\tilde{P})$ with respect to \tilde{p}_l , we have

$$\begin{aligned}
\nabla_l L_P(\tilde{P}) &= \left(c_l - \sum_s \mathbf{R}_{s,i} x \right) - p_l \frac{\prod_{k \in N_{to}^l(l)} \left(1 - \sum_{m \in L_{out}(k)} p_m \right) \varepsilon_k}{1 - \sum_{m \in L_{out}(t_i)} p_m} \\
&= \left(c_l - \sum_s \mathbf{R}_{s,i} x \right) - p_l \frac{\sum_{k \in L_{from}^l(t_i)} \varepsilon_k}{1 - \sum_{m \in L_{out}(t_i)} p_m} \tag{13}
\end{aligned}$$

Coming back to the P solution space instead of \tilde{P} , it is easy to verify that the derivate of $L_P(P)$ with respect to p_l is

$$\nabla_l L_P(P) = \frac{c_l - \sum_s \mathbf{R}_{s,i} x}{p_l} - \frac{\sum_{k \in L_{from}^l(t_i)} \varepsilon_k}{1 - \sum_{m \in L_{out}(t_i)} p_m} \tag{14}$$

Therefore, the logarithmic change of variables simply scales each entry of the gradient by p_l : $\nabla_l L_P(P) = \nabla_l L_P(\tilde{P})/p_l$. We now use the subgradient method [14], with a constant step size κ , to maximize $L_P(P)$

$$\begin{aligned}
p_l(t+1) &= p_l(t) + \kappa \nabla_l L_P(P) \\
&= \left[p_l(t) + \kappa \frac{c_l - \sum_s \mathbf{R}_{s,i} x}{p_l(t)} - \kappa \frac{\sum_{k \in L_{from}^l(t_i)} \varepsilon_k}{1 - \sum_{m \in L_{out}(t_i)} p_m} \right]_0^1
\end{aligned}$$

This is the exact MAC unit in the JOC algorithm. Substituting the known equation into $x_s(t+1) = [U'_s(p_s^{r^*}(t))]_{m_s}^{M_s}$ to compute the total rate of s at $t+1$, the following is the same as the proof in [8]. Since $x_{s,i}$ can be turned into a concave function in P , each constraint $x_s \leq \sum_{i=1}^{n_s} x_{s,i}(P)$ is upper bound constraint on a convex function in (x_s, P_s) , problem (6) can be turned into maximizing a strictly concave objective function over a convex constraint set. Therefore, the established convergence is towards the global optimum.

C. Extension: Fairness Issue for Cooperative Network

As stated previously, each user may transmit both its own bits as well as some information for its partner in the cooperative system, so how to keep the relative fairness between its own bits and partner's bits is a practical problem to be solved. In generic wireless network, the fairness strategy adopts the per-flow fairness, in which every flow has the equal "opportunity" to get to the destination, however, this is impractical in cooperative MHWN system. Here we can employ a content-based fairness strategy described in [15], which is scalable and does not require maintenance of any state information beyond a time slot which is important in a dynamic network. As to the content-based fairness strategy, that is when each node receives the packets, it judges the packet content whether it has hold or not. If has, it will throw out the packet directly and inform his partner do not transmit after that moment. If not, it will receive the packet and adjust the flow rate and persistence probability as stated before.

In addition, utility functions can also be interpreted as the "knobs" to control the tradeoff between the fairness and efficiency. Different shapes of utility functions lead to different types of fairness defined in the economics literature. For example, a family of utility functions, parameterized by $\alpha \geq 0$, is proposed as

$$U^\alpha = \begin{cases} (1 - \alpha)^{-1} x^{1-\alpha}, & \text{if } \alpha \neq 1 \\ \log x, & \text{otherwise} \end{cases} \quad (15)$$

If $\alpha = 0$, utility maximization reduces to system throughput maximization. If $\alpha = 1$, proportional fairness among competing users is attained; if $\alpha = 2$, then harmonic mean fairness; and if $\alpha \rightarrow \infty$, then max-min fairness. To accommodate multi-class services and attain the desired tradeoff between efficiency and fairness, it is important that the utility maximization framework can handle general types of convex or concave utility functions [16].

IV. NUMERICAL RESULTS

An illustrative numerical example is summarized below for the network with end-to-end paths and logical links shown in Fig. 2. Each of the three sources has its utility function parameterized by α as in (15). Due to page limit, we summarize the numerical results for the case of Node-to-Node. More specifically, there are two alternate paths from node A to C , i.e. a direct one-link path $A \rightarrow C$, and an indirect two-link path $A \rightarrow B \rightarrow C$. We assume that if the distance between the transmitter node and the receiver node is less than $2d$, the receiver node gets interference from the transmitter node.

Fig. 3 shows the convergence of link persistence probabilities regulated by JOC for the case of $\alpha = 3$. Fig. 4 shows the optimized source rates with each data point being the result of solving (6) for a given

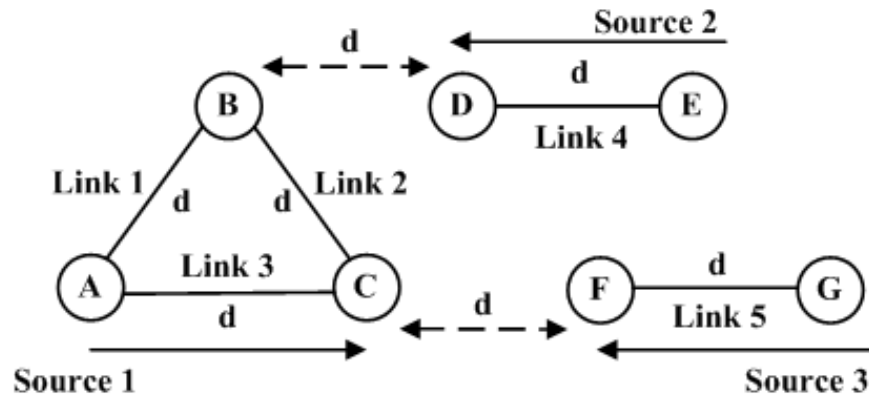

Fig. 2. Physical and logical topologies

fairness parameter α . A number of interesting observations can be made from this graph. For example, since source 1 traverses more heavily interfered links, at the optimal rate allocation that maximizes the network utility, it is allocated the lowest data rate. However, as the value of α increases, the gap among the source decreases, and the fairness among sources is improved.

V. CONCLUDING REMARKS

In this paper, we have been focusing on resolving the rate control, the medium access control and the routing problem for cooperative MHWN. At first, we construct a general mathematics model for the cooperative MHWN based on problem formulation. And then, we develop a joint optimal control algorithm which consists of the link capacity detection by adjusting persistence probability at the MAC layer, the flow rate control by achieving the maximal utility at the transport layer and the optimal routing at the network layer. In addition, fairness issue for the cooperative network is presented to improve the practical performance of the proposed algorithm.

VI. ACKNOWLEDGMENTS

This work is supported by the International Project PRA-SI (financed by France and China government) under Grant No.SI04-03, and the Nature Science Foundation of China under Grant No.60372107. What's more, we also thank the anonymous reviewers for insightful comments and suggestions.

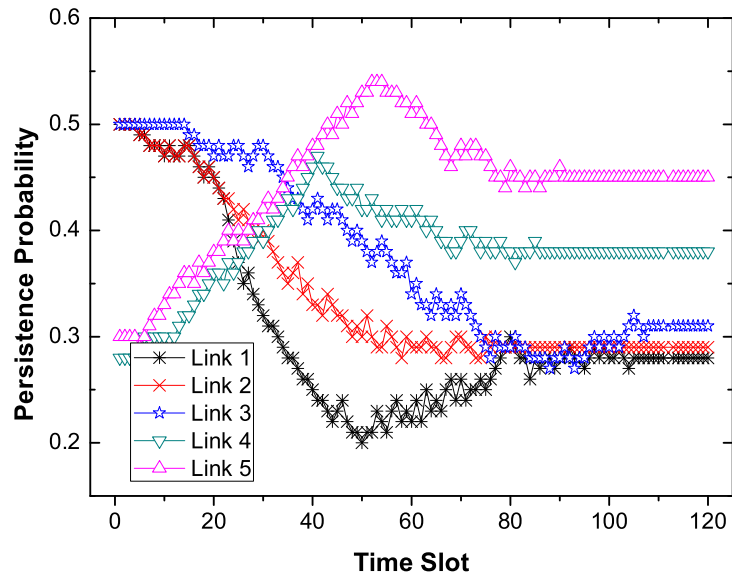

Fig. 3. Convergence of link persistence probabilities

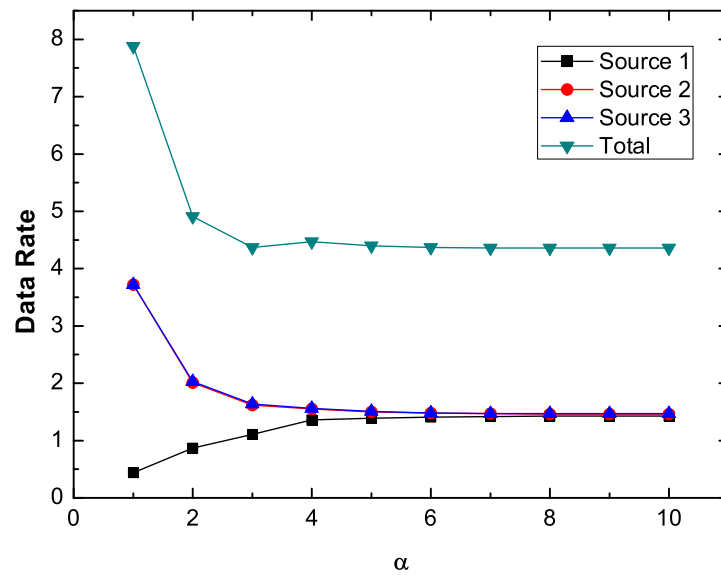

Fig. 4. Optimized source rates as fairness index α changes

APPENDIX I

PROOF OF STRICTLY CONCAVE FUNCTION

Taking derivatives again, for each of the nonlinear

$\sum_{i=1}^{n_s} \log[c_l p_l \prod_{k \in N_{to}^l(l)} (1 - \sum_{m \in L_{out}(k)} p_m) - \sum_{n \in L_{from}^l(t_l)} c_n p_n \prod_{k \in N_{to}^l(n), k \neq t_l} (1 - \sum_{m \in L_{out}(k)} p_m)]$ terms in $L_P(\tilde{P})$, we obtain the Hessian

$$H^l = \frac{-p_l}{(\sum_k (z_{lk}) + c_l p_l)^2} ((\sum_k z_{lk} + c_l p_l) \text{diag}(z_l) - z_l z_l^T) \quad (16)$$

where $z_{lk} = \exp(\tilde{p}_l) + c_l p_l \prod_{k \in N_{to}^l(l)} (1 - \sum_{m \in L_{out}(k)} p_m)$, and z_l is a column vector $[z_{l1}, z_{l2}, \dots, z_{lL}]^T$. Matrix H^l is indeed negative definite: for all vectors v ,

$$\begin{aligned} v^T H^l v &= \frac{-p_l (\sum_k (z_{lk}) + c_l p_l) (\sum_{k \in N_{to}^l(l)} (1 - \sum_{m \in L_{out}(k)} p_m) z_{lk})}{(\sum_k z_{lk} + c_l p_l)^2} \\ &+ \frac{p_l (\sum_{k \in N_{to}^l(l)} (1 - \sum_{m \in L_{out}(k)} p_m) z_{lk})^2}{(\sum_k z_{lk} + c_l p_l)^2} < 0 \end{aligned} \quad (17)$$

This is because the Cauchy Schwarz inequality $(a^T a)(b^T b) \geq (a^T b)^2$. Therefore, $L_P(\tilde{P})$ is a strictly concave function of \tilde{P} , and its Hessian is a negative definite block diagonal matrix $\text{diag}(H^1, H^2, \dots, H^L)$. ■

REFERENCES

- [1] A. Nosratinia, T. E. Hunter, A. Hedayat, "Cooperative communication in Wireless Networks", IEEE Communication Magazine, vol. 42, no.10, pp.74-80, Oct. 2004
- [2] Yao-Win Hong, Wan-Jen Huang, Fu-Hsuan Chiu etc., "Cooperative Communications in Resource-Constrained Wireless Networks", IEEE Signal Processing Magazine, vol.24, no.3, pp. 47-57, 2007.
- [3] Scaglione, A., Goeckel, D.L., Laneman, J.N., "Cooperative communications in mobile ad hoc networks", IEEE Signal Processing Magazine, vol.23, no.5, pp. 18-29, Sept. 2006.
- [4] Jakllari, G., Krishnamurthy, S.V., Faloutsos, M., etc., "On broadcasting with cooperative diversity in multi-hop wireless networks", IEEE Journal on Selected Areas in Communications, vol.25, no.2, pp.484-496, Feb.2007.
- [5] Sadek, A. K., Su, W., Liu, K. J. R., "Multinode Cooperative Communications in Wireless Networks" IEEE Transactions on Signal Processing, no. 55, no. 1, pp.341-355, Jan. 2007.
- [6] Yuan, J., Li, Z., Yu, W., Li, B, "A Cross-Layer Optimization Framework for Multihop Multicast in Wireless Mesh Networks", IEEE Journal on Selected Areas in Communications, vol.24, no.11, pp. 2092 -2103, Nov. 2006.
- [7] Gentian J, Srikanth V. K., Michalis F., etc., "On Broadcasting with Cooperative Diversity in Multi-Hop Wireless Networks", IEEE Journal on Selected Areas in Communications, vol.25, no.2, pp. 484-496, Feb. 2007.

- [8] X. Lin, Ness B. Shroff, "Utility Maximization for Communication Networks with Multi-path Routing", *IEEE Trans. on Automatic Control*, vol.51, no.5, pp.766-781, May 2006.
- [9] W.H. Wang, M. Palaniswami, and S. H. Low, "Optimal Flow Control and Routing in Multi-Path Networks", *Performance Evaluation*, vol. 52, no. 2-3, pp. 119-132, April 2003.
- [10] L. Chen, Steven H. Low, Mung Chiang, and John C.Doyle, "Cross-layer Congestion Control, Routing and Scheduling Design in Ad Hoc Wireless Networks", *INFOCOM 2006*.
- [11] R. T. Rockafellar, "Monotone Operators and the Proximal Point Algorithm", *SIAM J. Control and Optimization*, vol. 14, pp. 877-898, Aug. 1976.
- [12] M. Chiang, "To layer or not to layer: balancing transport and physical layers in wireless multihop networks", *Proc. IEEE INFOCOM*, vol.4, pp.2525-2536, Mar. 2004.
- [13] L. Xiao. M. Johnasson and S. Boyd, "Simultaneous routing and resource allocation via dual decomposition", *IEEE Trans. on Communications*, vol.52, no.7, pp. 1136-1144, July 2004.
- [14] S. H. Low, "A duality model of TCP and queue management algorithms", *IEEE/ACM Trans. on Networking*, vol. 11, no.4, pp. 525-536, Aug. 2003.
- [15] J. Mo and J. Walrand, "Fair end-to-end window-based congestion control," *IEEE/ACM Trans. on Networking*, vol. 8, no. 5, pp. 556-567, October 2000.
- [16] J-W. Lee, M. Chiang, and A. R. Calderbank, "Jointly optimal congestion and medium access control based on network utility maximization", *IEEE Communications Letters*, Vol. 10, No. 3, pp. 216-218, Mar. 2006.