



HAL
open science

Heredity for generalized power domination

Paul Dorbec, Seethu Varghese, Ambat Vijayakumar

► **To cite this version:**

Paul Dorbec, Seethu Varghese, Ambat Vijayakumar. Heredity for generalized power domination. 2015. hal-01207482v1

HAL Id: hal-01207482

<https://hal.science/hal-01207482v1>

Preprint submitted on 30 Sep 2015 (v1), last revised 21 Mar 2016 (v3)

HAL is a multi-disciplinary open access archive for the deposit and dissemination of scientific research documents, whether they are published or not. The documents may come from teaching and research institutions in France or abroad, or from public or private research centers.

L'archive ouverte pluridisciplinaire **HAL**, est destinée au dépôt et à la diffusion de documents scientifiques de niveau recherche, publiés ou non, émanant des établissements d'enseignement et de recherche français ou étrangers, des laboratoires publics ou privés.

Heredity for generalized power domination

Paul Dorbec^{1,2†} Seethu Varghese^{3‡} A. Vijayakumar^{3§}

¹Univ. Bordeaux, LaBRI, UMR 5800, F-33400 Talence, France

²CNRS, LaBRI, UMR 5800, F-33400 Talence, France

³Department of Mathematics, Cochin University of Science and Technology, Cochin-682022, India

In this paper, we study the behaviour of the generalized power domination number of a graph by small changes on the graph, namely edge and vertex deletion and edge contraction. We prove optimal bounds for $\gamma_{P,k}(G - e)$, $\gamma_{P,k}(G/e)$ and for $\gamma_{P,k}(G - v)$ in terms of $\gamma_{P,k}(G)$, and give examples for which these bounds are tight. We characterize all graphs for which $\gamma_{P,k}(G - e) = \gamma_{P,k}(G) + 1$ for any edge e . We also consider the behaviour of the propagation radius of graphs by similar modifications.

Keywords: power domination, electrical network monitoring, domination, edge critical graphs, propagation radius

1 Introduction

Domination is now a well studied graph parameter, and a classical topic in graph theory. To address the problem of monitoring electrical networks with *phasor measurement units* (see [3]), power domination was introduced as a variation of the classical domination [11]. The originality of power domination is the introduction of an additional propagation possibility, relative to the possible use of Kirchhoff's laws in an electrical network. From this propagation, a vertex can end up to be monitored even though it is at a large distance from any vertex in the graph. The original status of this new parameter and its applied motivation makes a subject of increasing interest from the community.

All graphs $G = (V(G), E(G))$ considered are finite and simple, that is, without multiple edges or loops. The *open neighbourhood* of a vertex v of G , denoted by $N_G(v)$, is the set of vertices adjacent to v . The *closed neighbourhood* of v is $N_G[v] = N_G(v) \cup \{v\}$. For a subset S of vertices, the *open* (resp. *closed*) *neighbourhood* $N_G(S)$ (resp. $N_G[S]$) of S is the union of the open (resp. closed) neighbourhoods of its elements. A vertex v in a graph is said to dominate its closed neighbourhood $N_G[v]$. A subset $S \subseteq V(G)$ of vertices is a dominating set if $N_G[S] = V(G)$, that is if every vertex in the graph is dominated by some vertex of S . The minimum size of a dominating set in a graph G is called its domination number, denoted by $\gamma(G)$.

For power domination, we need to define the set of vertices monitored by an initial set S (of PMU) iteratively. The initial set of vertices monitored by S is defined as the set of dominated vertices $\mathcal{P}_G^0(S) = N_G[S]$. This step is sometimes called the domination step. Then this set is iteratively extended by including all vertices that are the unique non-monitored neighbour of a monitored vertex. This second part is called the

[†]Email: dorbec@labri.fr.

[‡]Email: seethu333@gmail.com.

[§]Email: vambat@gmail.com.

propagation rule. More formally, we define directly the set of monitored vertices for k -power domination following the notation of [4] :

Definition 1 (Monitored vertices) Let G be a graph, $S \subseteq V(G)$ and $k \geq 0$. The sets $(\mathcal{P}_{G,k}^i(S))_{i \geq 0}$ of vertices monitored by S at step i are defined as follows:

$$\begin{aligned} \mathcal{P}_{G,k}^0(S) &= N_G[S] \text{ (domination step), and} \\ \mathcal{P}_{G,k}^{i+1}(S) &= \bigcup \{N_G[v] : v \in \mathcal{P}_{G,k}^i(S) \text{ such that } |N_G[v] \setminus \mathcal{P}_{G,k}^i(S)| \leq k\} \text{ (propagation steps).} \end{aligned}$$

Let us make some observations about this definition. First, the set of monitored vertices is monotone by inclusion, i.e. $\mathcal{P}_{G,k}^i(S) \subseteq \mathcal{P}_{G,k}^{i+1}(S)$. This is easy to check by induction, using the fact that whenever $N_G[v]$ has been included in $\mathcal{P}_{G,k}^i(S)$, it is included in $\mathcal{P}_{G,k}^{i+1}(S)$. This also implies that $\mathcal{P}_{G,k}^i(S)$ is always a union of neighbourhoods. Observe that when $k = 1$, the definition coincides with the intuition given above. Observe also that for some integer i_0 , $\mathcal{P}_{G,k}^{i_0}(S) = \mathcal{P}_{G,k}^{i_0+1}(S)$, then $\mathcal{P}_{G,k}^j(S) = \mathcal{P}_{G,k}^{i_0}(S)$ for all $j \geq i_0$. We thus denote this set $\mathcal{P}_{G,k}^{i_0}(S)$ by $\mathcal{P}_{G,k}^\infty(S)$. When the graph G is clear from the context, we simplify the notation to $\mathcal{P}_k^i(S)$ and $\mathcal{P}_k^\infty(S)$.

Definition 2 (k -power dominating set) A set S is a k -power dominating set of G (abbreviated k -PDS) if $\mathcal{P}_{G,k}^\infty(S) = V(G)$. The least cardinality of such a set is called the k -power domination number of G , denoted by $\gamma_{P,k}(G)$. A $\gamma_{P,k}(G)$ -set is a k -PDS in G of cardinality $\gamma_{P,k}(G)$.

Observe that k -power domination is also a generalization of domination, that we obtain when we set $k = 0$. In [4], the authors showed along with some early results about k -power domination that some bounds, extremal graphs and properties can be expressed for any k , including the case of domination. In [8], some bound from [17] on regular graphs is also generalized for any k .

The computational complexity of the power domination problem was considered in [1, 2, 10, 11], in which it was proved to be NP-complete on bipartite and chordal graphs as well as for bounded propagation variants. Linear-time algorithms are known for computing minimum k -power dominating sets in trees [4] and in block graphs [16]. The problem of characterizing the power domination number of a graph is non trivial for simple families of graphs. Early studies try to characterize it for products of paths/grids [7, 6] though do not reach complete characterization in a few cases. Other studies propose closed formulas for the power domination number in hexagonal grids [9] or in Sierpiński graphs [5].

In general, it remains difficult to prove lower bounds on the power domination number of a graph. One reason why it is so is that power domination do not behave well when taking subgraph. In this paper, we explore in detail the behaviour of the power domination number of a graph when small changes are applied to the graph, e.g. removing a vertex or an edge, or contracting an edge. (Recall that the graph obtained by contraction of an edge $e = xy$, denoted by G/e , is obtained from $G - e$ by replacing x and y by a new vertex v_{xy} (contracted vertex) which is adjacent to all vertices in $N_{G-e}(x) \cup N_{G-e}(y)$.) In particular, we prove in Section 2 that though the behaviour of the power domination is similar to the domination in the case of the removal of a vertex, the removal of an edge can decrease the power domination number and the contraction of an edge can increase the power domination number, both phenomena that are impossible in usual domination. We characterize the graphs for which the removal of any edge increases the k -power domination number.

Another recent but natural question about power domination is related to the propagation radius. In a graph, a vertex that is arbitrarily far apart from any vertex in the set S may eventually get monitored by S as in the case of paths. However, in the applied circumstances of the monitoring of an electrical network, applying too many times Kirchhoff's laws successively would induce an unreasonable cumulated margin of error. With this consideration in mind, it is natural to consider power domination with bounded time

constraints, as was first studied in [1], and then in [15]. Inspired by this study, the k -propagation radius of a graph G was introduced in [5] as a way to measure the efficiency of a minimum k -power dominating set (k -PDS). It gives the minimum number of propagation steps required to monitor the entire graph over all $\gamma_{\mathcal{P},k}(G)$ -sets.

Definition 3 *The radius of a k -PDS is defined by*

$$\text{rad}_{\mathcal{P},k}(G, S) = 1 + \min\{i : \mathcal{P}_{G,k}^i(S) = V(G)\}.$$

The k -propagation radius of the graph as defined in [5] can be expressed as

$$\text{rad}_{\mathcal{P},k}(G) = \min\{\text{rad}_{\mathcal{P},k}(G, S), S \text{ is a } k\text{-PDS of } G, |S| = \gamma_{\mathcal{P},k}(G)\}.$$

We finally recall a few graph notations that we use in the following. We denote by K_n the complete graph on n vertices, by $K_{m,n}$ the bipartite complete graph with partite sets of order m and n . The path and cycle on n vertices are denoted by P_n and C_n , respectively. For two graphs G and H , $G \square H$ denotes the Cartesian product of G and H , that is the graph with vertex set $V(G) \times V(H)$ and where two vertices (g, h) and (g', h') are adjacent if and only if either $g = g'$ and $hh' \in E(H)$, or $h = h'$ and $gg' \in E(G)$.

2 Variations on the power domination number

Before considering the different cases of vertex removal, edge removal and edge contraction, we propose the following technical lemma which should prove useful. It states that if two graphs differ only on parts that are already monitored, then propagation in the not yet monitored parts behave the same. For a graph $G = (V, E)$ and two subsets X and Y of V , we denote by $E(X, Y)$ the set of edges joining any vertex of X to any vertex of Y . Note that if $X \subseteq Y$, $E(X, Y)$ contains in particular all edges of the induced subgraph $G[X]$ of G on X . All along the rest of the paper, k denotes a positive integer.

Lemma 4 *Let $G = (V_G, E_G)$ and $H = (V_H, E_H)$ be two graphs, S a subset of vertices of G and i a non-negative integer. Define $X = V_G \setminus \mathcal{P}_{G,k}^i(S)$ and the subgraph G' with vertex set $N_G[X]$ and edge set $E_G(X, N_G[X])$. Suppose there exists a subset $Y \subseteq V_H$ such that the subgraph $H' = (N_H[Y], E(Y, N_H[Y]))$ is isomorphic to G' with a mapping $\varphi : N_G[X] \rightarrow N_H[Y]$ that maps X to Y . Then, if for some k -power dominating set $T \subseteq V_H$ and some integer j , $Y \subseteq V_H \setminus \mathcal{P}_{H,k}^j(T)$, then S is a k -PDS of G and $\text{rad}_{\mathcal{P},k}(G, S) \leq i - j + \text{rad}_{\mathcal{P},k}(H, T)$.*

Proof: For $\ell \geq 0$, denote by X^ℓ and Y^ℓ respectively the sets $X \cap \mathcal{P}_{G,k}^{i+\ell}(S)$ and $Y \cap \mathcal{P}_{H,k}^{j+\ell}(T)$. We prove by induction that for all ℓ , $Y^\ell \subseteq \varphi(X^\ell)$.

By hypothesis, $X^0 = \emptyset$ and so $\varphi(X^0) = \emptyset = Y^0$, so it holds for $\ell = 0$. Now assume that the property is true for some $\ell \geq 0$. Suppose that some vertex $v = \varphi(u) \in N_H[Y]$ satisfies the conditions for propagation in H at step $j + \ell$, i.e. $v \in \mathcal{P}_{H,k}^{j+\ell}(T)$ and $|N_H[v] \setminus \mathcal{P}_{H,k}^{j+\ell}(T)| \leq k$. We show that u also satisfies the conditions for propagation in G . First, remark that u is monitored at step $i + \ell$: indeed, if $u \notin X$, then by definition of X , $u \in \mathcal{P}_{G,k}^{i+\ell}$, otherwise if $u \in X$, then $v \in Y \cap \mathcal{P}_{H,k}^{j+\ell}(T) = Y^\ell$, and thus by induction, $u \in X^\ell \subseteq \mathcal{P}_{G,k}^{i+\ell}$. Now consider any neighbour u' of u not yet dominated. Then $u' \in X \setminus X^\ell$ and $\varphi(u') \in Y \setminus Y^\ell$. Moreover, by the isomorphism between G' and H' , $\varphi(u')$ is also adjacent to v , and was among the at most k non monitored neighbours of v in H . Therefore, u has at most k non monitored neighbours in G , and also propagates in G . Applying this statement to all vertices in G' , we infer that $Y^{\ell+1} \subseteq \varphi(X^{\ell+1})$. By induction, this is also true for $\ell = \text{rad}_{\mathcal{P},k}(H, T) - j - 1$, and we deduce that

$$X = \varphi^{-1}(Y) \subseteq \varphi^{-1}\left(Y^\ell = \left(\mathcal{P}_{H,k}^{\text{rad}_{\mathcal{P},k}(H,T)-j+i-1}(T) \cap Y\right)\right) \subseteq \left(X^\ell = \left(\mathcal{P}_{G,k}^{\text{rad}_{\mathcal{P},k}(H,T)-j+i-1}(S) \cap X\right)\right),$$

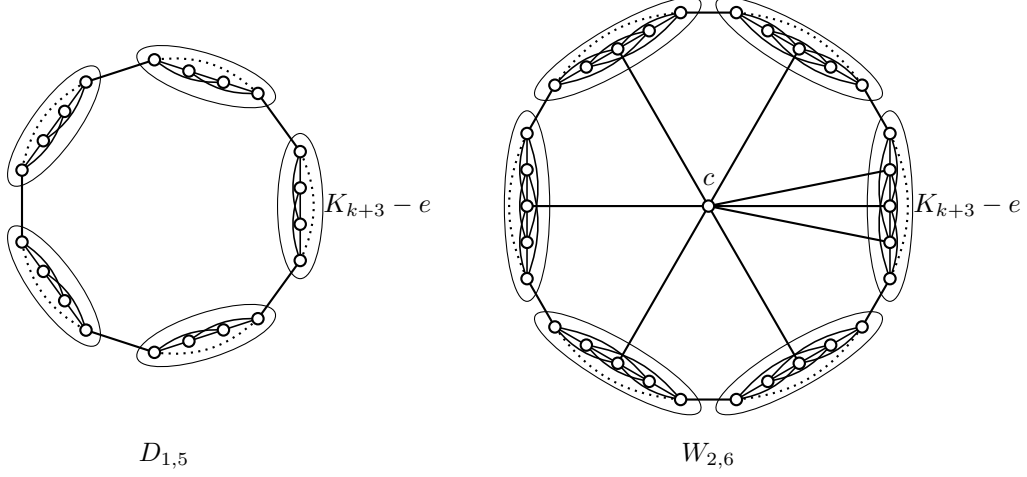

Fig. 1: The graphs $D_{k,n}$ and $W_{k,n}$ obtained by the addition of vertex c .

and thus that S is a k -power dominating set of G and $\text{rad}_{\mathbb{P},k}(G, S) \leq i - j + \text{rad}_{\mathbb{P},k}(H, T)$. \square

We now use this lemma to state how the k -power domination number of a graph may change with atomic variations of the graph.

2.1 Vertex removal

We denote by $G - v$ the graph obtained from G by removing a vertex v and all its incident edges. Similar to what happens for domination (see [12]), we have the following:

Theorem 5 *Let G be a graph and v be a vertex in G . There is no upper bound for $\gamma_{\mathbb{P},k}(G - v)$ in terms of $\gamma_{\mathbb{P},k}(G)$. On the other hand, we have $\gamma_{\mathbb{P},k}(G - v) \geq \gamma_{\mathbb{P},k}(G) - 1$ and this bound is tight. Moreover, when $\gamma_{\mathbb{P},k}(G - v) = \gamma_{\mathbb{P},k}(G) - 1$, then $\text{rad}_{\mathbb{P},k}(G) \leq \text{rad}_{\mathbb{P},k}(G - v)$.*

Proof:

We first prove the lower bound, using Lemma 4. We define $H = G - v$ with the obvious mapping φ from $V(G) \setminus v$ to $V(H)$. Let T be a power dominating set of $H = G - v$, that induces the minimum propagation radius. Then for the set $S = T \cup \{v\}$, the conditions of Lemma 4 hold already from $i = 0$ and $j = 0$ and the bound follows. Moreover, we also get that $\text{rad}_{\mathbb{P},k}(G, S) \leq j - i + \text{rad}_{\mathbb{P},k}(H, T) = \text{rad}_{\mathbb{P},k}(G - v)$.

A first example for which the tightness of this lower bound can be observed is the 4×4 grid $P_4 \square P_4$, for which we get $\gamma_{\mathbb{P},1}(P_4 \square P_4) = 2$ and $\gamma_{\mathbb{P},1}((P_4 \square P_4) - v) = 1$ for any v . Simple examples for larger k are the graph $K_{k+2,k+2}$, for which the removal of any vertex drops the k -power domination number from two to one, as well as the complete bipartite graph $K_{k+3,k+3}$ minus a perfect matching. We now describe two infinite families of graphs to illustrate these bounds. The family of graphs $D_{k,n}$ was defined in [4]. It is made of n copies of $k + 3$ -cliques minus an edge, organized into a cycle, and where the extremities of the missing edges are linked to the corresponding vertices in the adjacent cliques in the cycle (see Fig. 1).

Note that $\gamma_{\mathbb{P},k}(D_{k,n}) = n$, as each copy of $K_{k+3} - e$ must contain a vertex of a k -power dominating set. Its propagation radius is one since $D_{k,n}$ has a dominating set of size n . The removal of a vertex on the cycle does not change its k -power domination number, but the removal of any other vertex decreases it by

one (and increases the radius from one to two). So this forms an infinite family tightening the lower bound for any value of k and $\gamma_{\mathbb{P},k}(G)$.

For proving there is no upper bound for $\gamma_{\mathbb{P},k}(G - v)$ in terms of $\gamma_{\mathbb{P},k}(G)$, we can consider the star with n leaves $K_{1,n}$, for which the removal of the central vertex increases the k -power domination number from 1 to n . A more interesting example is a generalization of the wheel $W_{k,n}$ (depicted in Fig. 1). It is made of $D_{k,n}$ together with a vertex c adjacent to three vertices of degree $k + 2$ in one particular clique and to one vertex of degree $k + 2$ in all the other cliques. Observe that for $n \geq k + 2$, $\{c\}$ is the only power dominating set of $W_{k,n}$ of order one, and thus we get $\text{rad}_{\mathbb{P},k}(W_{k,n}) = \text{rad}_{\mathbb{P},k}(W_{k,n}, \{c\}) = 2 + 3\lfloor \frac{n-1}{2} \rfloor + 2((n-1) \bmod 2)$. The removal of c induces the graph $D_{k,n}$, increasing the k -power domination number from 1 to n , and dropping the propagation radius from roughly $\frac{3n}{2}$ to 1. \square

More constructions could be proposed to show that the propagation radius of the graph can evolve quite freely when a vertex is removed, and there is little hope for other bounds on this parameter when a vertex is removed. The most unlikely example is that the removal of a vertex increase both the k -power domination number and the propagation radius by unbounded value. This is possible with the following variation on $W_{k,pn}$. Consider pn subgraphs $(H_i)_{0 \leq i < pn}$, all isomorphic to a clique minus an edge, on $k + 3$ vertices when $i \equiv 0 \pmod p$ and on $k + 1$ vertices otherwise. We again connect the extremities of the missing edges in the clique into a cycle joining H_i to $H_{i+1 \pmod{pn}}$, and add a vertex c adjacent to three vertices of degree $k + 2$ in all copies H_i when $i \equiv 0 \pmod p$, and to one vertex of degree k in all the other copies. Then $\{c\}$ is a k -power dominating set of G inducing a propagation radius of two. On the other hand, $\gamma_{\mathbb{P},k}(G - c) = n$ (one vertex is needed in each $H_i, i \equiv 0 \pmod p$) and has propagation radius $1 + 3\lfloor \frac{pn-1}{2} \rfloor + 2((pn-1) \bmod 2)$.

2.2 Edge removal

In a graph G , removing an edge e can never decrease the domination number. More generally, we have that $\gamma(G) \leq \gamma(G - e) \leq \gamma(G) + 1$. However, the removal of an edge can decrease the k -power domination number as stated in the following result. Indeed, it may happen that the removal of one edge allows the propagation through another edge incident to a common vertex, and thus decreases the power domination number.

Theorem 6 *Let G be a graph and e be an edge in G . Then*

$$\gamma_{\mathbb{P},k}(G) - 1 \leq \gamma_{\mathbb{P},k}(G - e) \leq \gamma_{\mathbb{P},k}(G) + 1.$$

Moreover,

$$\begin{cases} \text{if } \gamma_{\mathbb{P},k}(G) - 1 = \gamma_{\mathbb{P},k}(G - e), \text{ then } \text{rad}_{\mathbb{P},k}(G) \leq \text{rad}_{\mathbb{P},k}(G - e) \\ \text{if } \gamma_{\mathbb{P},k}(G - e) = \gamma_{\mathbb{P},k}(G) + 1, \text{ then } \text{rad}_{\mathbb{P},k}(G - e) \leq \text{rad}_{\mathbb{P},k}(G). \end{cases}$$

Proof: We first prove that $\gamma_{\mathbb{P},k}(G - e) \leq \gamma_{\mathbb{P},k}(G) + 1$. Let T be a $\gamma_{\mathbb{P},k}(G)$ -set. If T is also a k -PDS of $G - e$, then we are done, so assume T is not. Let j_0 be the smallest integer j such that $\mathcal{P}_{G,k}^j(T) \not\supseteq \mathcal{P}_{G-e,k}^j(T)$, and let v be a vertex in $\mathcal{P}_{G,k}^{j_0}(T) \setminus \mathcal{P}_{G-e,k}^{j_0}(T)$. Since $v \in \mathcal{P}_{G,k}^{j_0}(T)$, there exists some neighbour u of v in $\mathcal{P}_{G,k}^{j_0-1}(T)$ such that $|N_G[u] \setminus \mathcal{P}_{G,k}^{j_0-1}(T)| \leq k$. Since $N_{G-e}[u] \subseteq N_G[u]$, $N_{G-e}[u]$ is also included in $\mathcal{P}_{G-e,k}^{j_0}(T)$, and v cannot be a neighbour of u any more, so $e = uv$. Thus we choose $S = T \cup \{v\}$ and using Lemma 4 (with the obvious mapping from $G - e$ to G , and $i = j = j_0$), we get that S is a k -PDS of $G - e$ of order $\gamma_{\mathbb{P},k}(G) + 1$. We also get that if $\gamma_{\mathbb{P},k}(G - e) = \gamma_{\mathbb{P},k}(G) + 1$, then $\text{rad}_{\mathbb{P},k}(G - e) \leq \text{rad}_{\mathbb{P},k}(G)$.

We now prove that $\gamma_{\mathbb{P},k}(G) - 1 \leq \gamma_{\mathbb{P},k}(G - e)$. Let T be a minimum k -PDS of $H = G - e$ and u be an extremity of e . We apply Lemma 4, for $S = T \cup \{u\}$ and $i = j = 0$. We get that S is a k -PDS of G and

$\text{rad}_{\mathbb{P},k}(G, S) = \text{rad}_{\mathbb{P},k}(G - e, T)$. We infer that if S is minimal (that is $\gamma_{\mathbb{P},k}(G) = \gamma_{\mathbb{P},k}(G - e) + 1$), then $\text{rad}_{\mathbb{P},k}(G) \leq \text{rad}_{\mathbb{P},k}(G - e)$. \square

As an illustration of these possibilities, in the graph G drawn in Fig. 2, the removal of the edge e_1 decreases the k -power domination number, the removal of the edge e_3 increases it, and the removal of the edge e_2 does not have any consequence.

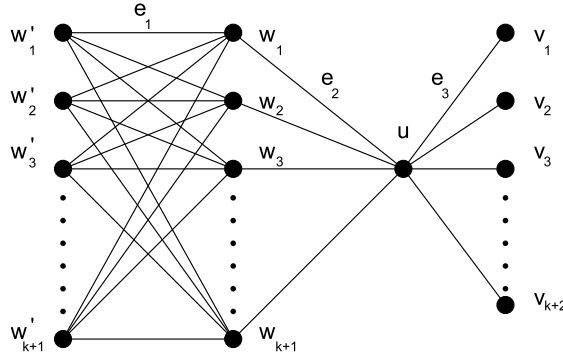

Fig. 2: A graph G where $\gamma_{\mathbb{P},k}(G) = 2 = \gamma_{\mathbb{P},k}(G - e_2)$, $\gamma_{\mathbb{P},k}(G - e_1) = 1$, $\gamma_{\mathbb{P},k}(G - e_3) = 3$.

We now propose a graph family where the removal of an edge decreases the k -power domination number but increases its propagation radius arbitrarily. The graph $G_{k,r,a}$ represented in Fig. 3 satisfies $\gamma_{\mathbb{P},k}(G) = 2$ and $\text{rad}_{\mathbb{P},k}(G) = a + 2$ (which is reached with the initial set $\{u, v\}$). If the edge e is removed, we get a new graph whose k -power domination number is 1 and which has propagation radius $(r + 3)(a + 1) + 2$. So no upper bound can be found for $\text{rad}_{\mathbb{P},k}(G - e)$ (in terms of $\text{rad}_{\mathbb{P},k}(G)$) when the removal of an edge decreases the power domination number.

Similar graphs where the edge removal increases the power domination number can also be found. For example, in the graph $G_{k,r,a}$, if we remove the topmost path of length $a + 2$ from w to v , except for the vertex adjacent to v , we get another graph G' such that $\{u\}$ is the only $\gamma_{\mathbb{P},k}(G')$ -set of order one, and with $\text{rad}_{\mathbb{P},k}(G') = (r + 2)(a + 1) + 3$. Removing the same edge e , now $\{u, v\}$ is a minimum $\gamma_{\mathbb{P},k}(G' - e)$ -set and $\text{rad}_{\mathbb{P},k}(G' - e) = a + 2$. This illustrates the fact that no lower bound can be found for $\text{rad}_{\mathbb{P},k}(G - e)$ (in terms of $\text{rad}_{\mathbb{P},k}(G)$) when the removal of an edge increases the power domination number.

We now characterize the graphs for which the removal of any edge increases the power domination number. Define a *generalized spider* as a tree with at most one vertex of degree $k + 2$ or more. See Fig. 4 for an example.

Theorem 7 *Let G be a graph. For each edge e in G , $\gamma_{\mathbb{P},k}(G - e) > \gamma_{\mathbb{P},k}(G)$ if and only if G is a disjoint union of generalized spiders.*

Proof:

First observe that if G is a disjoint union of generalized spiders, then its k -power domination number is exactly its number of components, and clearly $\gamma_{\mathbb{P},k}(G - e) > \gamma_{\mathbb{P},k}(G)$ for any edge e in G .

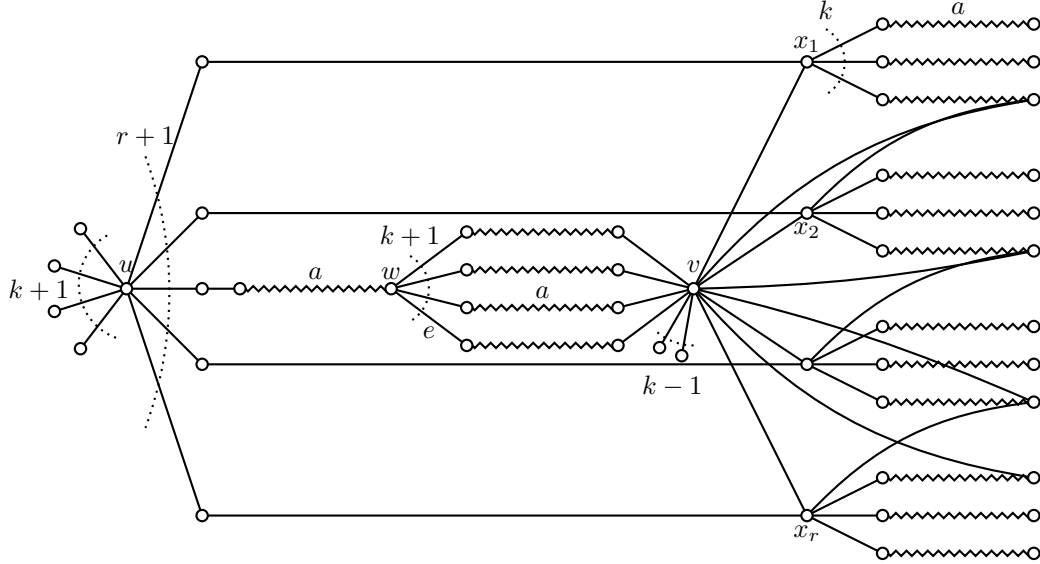

Fig. 3: The graph $G_{k,r,a}$ for $k = 3$ and $r = 4$ (zigzag edges represent paths of length a).

Let G be a graph and let S be a $\gamma_{P,k}(G)$ -set. We label the vertices of G with integers from 1 to n and consider the subsequent natural ordering on the vertices. For $i \geq 0$, we define $E'_i \subseteq E(G)$ as follows:

$$\begin{cases} E'_0 = \{uv \in E(G) \mid v \in N(S) \setminus S, u = \min\{x \in N(v) \cap S\}\} \\ E'_{i+1} = \{uv \in E(G) \mid v \in \mathcal{P}_k^{i+1}(S) \setminus \mathcal{P}_k^i(S), u = \min\{x \in \mathcal{P}_k^i(S) \cap N(v), |N[x] \setminus \mathcal{P}_k^i(S)| \leq k\}\} \end{cases}$$

where the minima are taken according to the ordering of the vertices. Let E' be the union of all E'_i for $i \geq 0$. If we consider the edges of E' as defined above oriented from u to v , then the in-degree of each vertex not in S is 1, of vertices in S is 0. Also the graph is acyclic, and each vertex not in S has out-degree at most k . Thus the graph induced by E' is a forest of generalized spiders. Note also that S is a k -PDS of this graph. We now assume that for any edge $e \in E(G)$, $\gamma_{P,k}(G - e) > \gamma_{P,k}(G)$, and we then prove that $E' = E(G)$.

By way of contradiction, suppose there exists an edge e in $E(G)$ and not in E' . We prove that S is a k -PDS of $G - e$. For that, we prove by induction that for all i , $\mathcal{P}_{G,k}^i(S) \subseteq \mathcal{P}_{G-e,k}^i(S)$. First observe that $\mathcal{P}_{G-e,k}^0(S) = \mathcal{P}_{G,k}^0(S)$. Indeed, suppose there exists a vertex x in $\mathcal{P}_{G,k}^0(S)$ but not in $\mathcal{P}_{G-e,k}^0(S)$, then e has to be of the form xv with $v \in S$. But since $e \notin E'_0$, there exists another vertex $u < v$ in S such that $ux \in E'_0$, and $x \in \mathcal{P}_{G-e,k}^0(S)$.

Assume now $\mathcal{P}_{G,k}^i(S) \subseteq \mathcal{P}_{G-e,k}^i(S)$ for some $i \geq 0$, and let us prove that $\mathcal{P}_{G,k}^{i+1}(S) \subseteq \mathcal{P}_{G-e,k}^{i+1}(S)$. Let x be a vertex in $\mathcal{P}_{G,k}^{i+1}(S)$. If $x \in \mathcal{P}_{G,k}^i(S)$, then by induction hypothesis, $x \in \mathcal{P}_{G-e,k}^{i+1}(S)$. If $x \notin \mathcal{P}_{G,k}^i(S)$, then there exists a vertex $v \in \mathcal{P}_{G,k}^i(S)$, $x \in N_G[v]$ such that $|N_G[v] \setminus \mathcal{P}_{G,k}^i(S)| \leq k$. Suppose $e \neq xv$. Then, since $N_{G-e}[v] \subseteq N_G[v]$ and by induction hypothesis, $v \in \mathcal{P}_{G-e,k}^i(S)$, $x \in N_{G-e}[v]$ and $|N_{G-e}[v] \setminus \mathcal{P}_{G-e,k}^i(S)| \leq k$, which implies $x \in \mathcal{P}_{G-e,k}^{i+1}(S)$. If $e = xv$ then by the choice of E'_{i+1} , there exists a vertex $w \in \mathcal{P}_{G,k}^i(S)$, $w < v$, $wx \in E'_{i+1}$ such that $|N_G[w] \setminus \mathcal{P}_{G,k}^i(S)| \leq k$ and $x \in N_G[w] \setminus \mathcal{P}_{G,k}^i(S)$. Then by induction hypothesis, $w \in \mathcal{P}_{G-e,k}^i(S)$, $x \in N_{G-e}[w]$ and $|N_{G-e}[w] \setminus \mathcal{P}_{G-e,k}^i(S)| \leq k$, which implies $x \in \mathcal{P}_{G-e,k}^{i+1}(S)$. Therefore $E(G) = E'$ and G is indeed a union of generalized spiders. \square

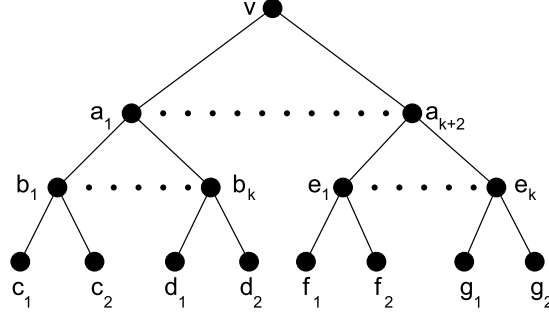

Fig. 4: A generalized spider, T

Observe that there also exist graphs for which the removal of any edge decreases the power domination number, though we did not manage to characterize them. The simplest example is the complete bipartite graph $K_{k+2, k+2}$, in which the removal of any edge decreases the k -power domination number from two to one. This graph already played a noticeable role among the $k+2$ -regular graphs, as observed in [8]. Another example is the graph $K_{k+3, k+3} - M$, where M is a perfect matching, in which we have $\gamma_{P,k}(K_{k+3, k+3} - M) = 2$ and $\gamma_{P,k}((K_{k+3, k+3} - M) - e) = 1$ for any edge e . More complex examples are the Cartesian product of K_4 and W_5 , where the k -power domination number decreases from three to two. A general family of graphs having this property is the Cartesian product of two complete graphs of the same order $K_a \square K_a$, which shall be described in Section 2.4.

2.3 Edge contraction

Contracting an edge in a graph may decrease its domination number by one, but cannot increase it [14]. As we prove in the following, increasing of the power domination number may occur.

Theorem 8 *Let G be a graph and e be an edge in G . Then*

$$\gamma_{P,k}(G) - 1 \leq \gamma_{P,k}(G/e) \leq \gamma_{P,k}(G) + 1.$$

Moreover,

$$\begin{cases} \text{if } \gamma_{P,k}(G) - 1 = \gamma_{P,k}(G/e), \text{ then } \text{rad}_{P,k}(G) \leq \text{rad}_{P,k}(G/e) \\ \text{if } \gamma_{P,k}(G/e) = \gamma_{P,k}(G) + 1, \text{ then } \text{rad}_{P,k}(G/e) \leq \text{rad}_{P,k}(G). \end{cases}$$

Proof: Let $e = xy$ be an arbitrary edge in G , we denote by v_{xy} the vertex obtained by contraction of e in G/e . We first prove that $\gamma_{P,k}(G/e) \geq \gamma_{P,k}(G) - 1$. Let T be a minimum k -PDS of $H = G/e$. Suppose first that the vertex $v_{xy} \in T$, then taking $S = T \setminus \{v_{xy}\} \cup \{x, y\}$, the conditions of Lemma 4 hold from $i = j = 0$ with the natural mapping from $G \setminus \{x, y\}$ to $H \setminus v_{xy}$. We infer that S is a k -PDS of G and $\text{rad}_{P,k}(G, S) = \text{rad}_{P,k}(G/e, T)$. We now consider the case when $v_{xy} \notin T$. Let j_0 be the smallest j such that $v_{xy} \in \mathcal{P}_{G/e, k}^j(T)$. Let w be a neighbour of v_{xy} that brought v_{xy} in $\mathcal{P}_{G/e, k}^j(T)$, i.e. if $j_0 = 0$, w is a neighbour of v_{xy} in T , otherwise when $j_0 > 0$, w is a neighbour of v_{xy} in $\mathcal{P}_{G/e, k}^{j_0-1}(T)$ such that $|N_{G/e}[w] \setminus \mathcal{P}_{G/e, k}^{j_0-1}(T)| \leq k$. By definition of edge contraction, the edge wv_{xy} corresponds to an edge wx or wy in $E(G)$. If $wx \in E(G)$, then take $S = T \cup \{y\}$, otherwise take $S = T \cup \{x\}$. Then, applying Lemma 4 (with the natural mapping from $G \setminus \{x, y\}$ to $H \setminus v_{xy}$ and $i = j = j_0$), we get that S is a

k -PDS of G and $\text{rad}_{\mathcal{P},k}(G, S) = \text{rad}_{\mathcal{P},k}(G/e, T)$. This implies that if $\gamma_{\mathcal{P},k}(G) = \gamma_{\mathcal{P},k}(G/e) + 1$, then $\text{rad}_{\mathcal{P},k}(G) \leq \text{rad}_{\mathcal{P},k}(G/e)$.

We now prove that $\gamma_{\mathcal{P},k}(G/e) \leq \gamma_{\mathcal{P},k}(G) + 1$. Let T be a minimum k -PDS of G and let $S = T \setminus \{x, y\} \cup \{v_{xy}\}$. Let j_0 be the smallest j such that $N_G[x] \cup N_G[y] \subseteq \mathcal{P}_{G,k}^j(T)$. Here also, we can use Lemma 4 (with the natural mapping from $(G/e) \setminus v_{xy}$ to $G \setminus \{x, y\}$ and $i = j = j_0$), and get that S is k -PDS of G/e . We also get that if $\gamma_{\mathcal{P},k}(G/e) = \gamma_{\mathcal{P},k}(G) + 1$, then $\text{rad}_{\mathcal{P},k}(G/e) \leq \text{rad}_{\mathcal{P},k}(G)$. \square

The bounds in Theorem 8 are tight. For example, the lower bound holds for the graphs $K_{k+2, k+2}$ and $K_{k+3, k+3} - M$, where M is a perfect matching, but also for the Cartesian product of two complete graphs of same order $K_a \square K_a$, as is described in the next section. The upper bound is attained for example for the generalized spider T in Fig. 4, which satisfy $\gamma_{\mathcal{P},k}(T) = 1$ and $\gamma_{\mathcal{P},k}(T/a_1 b_1) = 2$ for $k \geq 2$.

2.4 On the Cartesian product of twin complete graphs

The Cartesian product of two complete graphs of same (large enough) order is such that removing a vertex, removing an edge or contracting an edge decrease its power domination number. We here prove these properties.

Observation 9 *Let $a \geq 1$ and $G = K_a \square K_a$. Then $\gamma_{\mathcal{P},k}(G) = \begin{cases} a - k & \text{if } a \geq k + 2, \\ 1 & \text{otherwise.} \end{cases}$*

Proof: Denote by $\{v_1, \dots, v_a\}$ the vertices of K_a . If $a < k + 2$, then any vertex in $G = K_a \square K_a$ is a minimum k -PDS. Now, assume $a \geq k + 2$. Let $S = \{(v_i, v_i) \mid 1 \leq i \leq a - k\}$. Then $\mathcal{P}_k^0(S) = \{(v_i, v_j) \mid i \leq a - k \text{ or } j \leq a - k\}$ and the set of vertices $A = \{(v_i, v_j) \mid a - k + 1 \leq i, j \leq a\}$ is yet to be monitored. Since any vertex in $\mathcal{P}_k^0(S) \setminus A$ has either 0 or k neighbours in A and each vertex in A is adjacent to some vertex in $\mathcal{P}_k^0(S)$, $\mathcal{P}_k^1(S)$ covers the whole graph. Thus S is a k -PDS of G . Therefore, $\gamma_{\mathcal{P},k}(G) \leq a - k$.

We now prove that $\gamma_{\mathcal{P},k}(G) \geq a - k$. By way of contradiction, suppose S is a k -PDS of G such that $|S| \leq a - k - 1$. Without loss of generality, assume that the elements of S belong to the first $a - k - 1$ columns and rows of G . Then the vertices in the set $B = \{(v_i, v_j) \mid a - k \leq i, j \leq a\}$ are not adjacent to any vertex in S , and $\mathcal{P}_k^0(S) \cap B = \emptyset$. Since any vertex in $G \setminus B$ has either 0 or $k + 1$ neighbours in B , no vertices from this set may get monitored later on, a contradiction. \square

Observation 10 *Let $a \geq k + 2$ and $G = K_a \square K_a$. Then $\gamma_{\mathcal{P},k}(G - v) = a - k - 1$ for any vertex v in $V(G)$.*

Proof: Denote by $\{v_1, \dots, v_a\}$ the vertices of K_a . We prove the result for $v = (v_1, v_1)$ which induce the result for any v by vertex transitivity. First observe that $S = \{(v_i, v_i) \mid 2 \leq i \leq a - k\}$ is a k -PDS of $G - v$. Indeed $\mathcal{P}_k^0(S) = \{(v_i, v_j) \mid 2 \leq i \leq a - k \text{ or } 2 \leq j \leq a - k\}$ then vertices (v_i, v_1) (resp. (v_1, v_i)) with $2 \leq i \leq a - k$ have only vertices (v_j, v_1) (resp. (v_1, v_j)) with $a - k + 1 \leq j \leq a$ as unmonitored neighbours, which are thus all in $\mathcal{P}_k^1(S)$. The next propagation step covers the graph. Thus S is a k -PDS of $G - v$ and $\gamma_{\mathcal{P},k}(G - v) \leq a - k - 1$. Now by Theorem 5 and Observation 9, $\gamma_{\mathcal{P},k}(G - v) \geq a - k - 1$. \square

Observation 11 *Let $a \geq k + 2$ and $G = K_a \square K_a$. Then $\gamma_{\mathcal{P},k}(G - e) = a - k - 1$ for any edge e in $E(G)$.*

Proof: Denote by $\{v_1, \dots, v_a\}$ the vertices of K_a . By edge transitivity of G , we can assume that $e = (v_1, v_1)(v_2, v_1)$. Let $S = \{(v_i, v_i) \mid 2 \leq i \leq a - k\}$. Then $\mathcal{P}_k^0(S) = \{(v_i, v_j) \mid 2 \leq i \leq a - k \text{ or } 2 \leq j \leq a - k\}$. Now the vertex (v_2, v_1) has only k unmonitored neighbours, namely the vertices (v_j, v_1) for $a - k < j \leq a$, and they all are in $\mathcal{P}_k^1(S)$. Then all vertices (v_j, v_2) for $a - k < j \leq a$ have only k

unmonitored neighbours and thus $\mathcal{P}_k^2(S)$ contains all vertices (v_i, v_j) for $i \geq 2$. Then $\mathcal{P}_k^3(S)$ contains the whole graph and $\gamma_{\mathcal{P},k}(G-e) \leq a-k-1$. The lower bound follows from Theorem 6 and Observation 9. \square

Observation 12 *Let $a \geq k+2$ and $G = K_a \square K_a$. Then $\gamma_{\mathcal{P},k}(G/e) = a-k-1$ for any edge e in $E(G)$.*

Proof: Denote by $\{v_1, \dots, v_a\}$ the vertices of K_a . By edge transitivity of G , we can assume that $e = (v_1, v_1)(v_2, v_1)$ and we denote by v_e the vertex in G/e obtained by contracting (v_1, v_1) and (v_2, v_1) . Let $S = \{v_e\} \cup \{(v_i, v_i) \mid 3 \leq i \leq a-k\}$. Then $\mathcal{P}_k^0(S)$ contains all vertices (v_i, v_j) with $1 \leq i \leq a-k$ and $1 \leq j \leq a$. After one propagation step, the whole graph is monitored so $\gamma_{\mathcal{P},k}(G/e) \leq a-k-1$. The lower bound follows from Theorem 8 and Observation 9. \square

Acknowledgements

The authors thank the Erudite programme of the Kerala State Higher Education Council, Government of Kerala, India for funding the visit of the first author during March 2014. The second author is supported by Maulana Azad National Fellowship (F1-17.1/2012-13/MANF-2012-13-CHR-KER-15793) of the University Grants Commission, India.

References

- [1] A. Aazami, Domination in graphs with bounded propagation: algorithms, formulations and hardness results. *J. Comb. Optim.* 19 (2010), no. 4, 429–456.
- [2] A. Aazami, M.D. Stulp, Approximation algorithms and hardness for domination with propagation, *SIAM J. Discrete Math.* 23 (2009), no. 3, 1382–1399.
- [3] T. L. Baldwin, L. Mili, M. B. Boisen Jr, R. Adapa, Power system observability with minimal phasor measurement placement, *IEEE Trans. Power Systems* 8 (1993), no. 2, 707–715.
- [4] G. J. Chang, P. Dorbec, M. Montassier, A. Raspaud, Generalized power domination of graphs, *Discrete Appl. Math.* 160 (2012), no. 12, 1691–1698.
- [5] P. Dorbec, S. Klavžar, Generalized power domination: propagation radius and Sierpiński graphs, *Acta Appl. Math.* 134 (2014), no. 1, 75–86.
- [6] P. Dorbec, M. Mollard, S. Klavžar, S. Špacapan, Power domination in product graphs, *SIAM J. Discrete Math.* 22 (2008), no. 2, 554–567.
- [7] M. Dorfling, M. A. Henning, A note on power domination in grid graphs, *Discrete Appl. Math.*, 154 (2006), no. 6, 1023–1027.
- [8] P. Dorbec, M. A. Henning, C. Löwenstein, M. Montassier, A. Raspaud, Generalized power domination in regular graphs, *SIAM J. Discrete Math.* 27 (2013) 1559–1574.
- [9] D. Ferrero, Seema Varghese, A. Vijayakumar, Power domination in honeycomb networks, *J. Discrete Math. Sciences and Crypt.* 14 (2011), no. 6, 521–529.
- [10] J. Guo, R. Niedermeier, D. Raible, Improved algorithms and complexity results for power domination in graphs, *Algorithmica* 52 (2008), no. 2, 177–202.

- [11] T. W. Haynes, S. M. Hedetniemi, S. T. Hedetniemi, M. A. Henning, Domination in graphs applied to electric power networks, *SIAM J. Discrete Math.* 15 (2002), no. 4, 519–529.
- [12] T. W. Haynes, S. T. Hedetniemi, P. J. Slater (Eds.), *Fundamentals of Domination in Graphs*, Marcel Dekker, Inc., New York, 1998.
- [13] T. W. Haynes, S. T. Hedetniemi, P. J. Slater (Eds.), *Domination in Graphs: Advanced Topics*, Marcel Dekker, Inc., New York, 1998.
- [14] J. Huang, J.-M. Xu, Note on conjectures of bondage numbers of planar graphs, *Appl. Math. Sci.*, 6 (2012), no. 66, 3277 - 3287.
- [15] C.-S. Liao, Power domination with bounded time constraints, *J. Comb. Optim.* (2014) 1–18.
- [16] C. Wang, L. Chen, C. Lu, k -Power domination in block graphs, *J. Comb. Optim.* (2014) 1–9.
- [17] M. Zhao, L. Kang, G. J. Chang, Power domination in graphs, *Discrete Math.* 306 (2006), no. 15, 1812–1816.