



**HAL**  
open science

## Constructive solution of inverse parametric linear/quadratic programming problems

Ngoc Anh Nguyen, Sorin Olaru, Pedro Rodriguez-Ayerbe, Morten Hovd,  
Necoara Ion

► **To cite this version:**

Ngoc Anh Nguyen, Sorin Olaru, Pedro Rodriguez-Ayerbe, Morten Hovd, Necoara Ion. Constructive solution of inverse parametric linear/quadratic programming problems. [Research Report] Centrale-Supélec. 2015. hal-01207234v1

**HAL Id: hal-01207234**

**<https://hal.science/hal-01207234v1>**

Submitted on 30 Sep 2015 (v1), last revised 14 Sep 2016 (v3)

**HAL** is a multi-disciplinary open access archive for the deposit and dissemination of scientific research documents, whether they are published or not. The documents may come from teaching and research institutions in France or abroad, or from public or private research centers.

L'archive ouverte pluridisciplinaire **HAL**, est destinée au dépôt et à la diffusion de documents scientifiques de niveau recherche, publiés ou non, émanant des établissements d'enseignement et de recherche français ou étrangers, des laboratoires publics ou privés.

## Constructive solution of inverse parametric linear/quadratic programming problems

N. A. Nguyen · S. Oлару · P. Rodriguez-Ayerbe ·  
M. Hovd · I. Necoara

the date of receipt and acceptance should be inserted later

**Abstract** Inverse parametric linear/quadratic programming has recently received increasing attention due to its promising relevance in constrained control design for linear systems. Its aim is to construct an appropriate optimization problem composed of a set of linear constraints and a cost function such that the optimal solution to such a problem, is equivalent to the given continuous piecewise affine function defined over a polyhedral partition. This paper introduces a *constructive procedure* to find this formulation. The main idea is based on *convex lifting*. Accordingly, an algorithm to construct convex liftings of a given *convexly liftable partition* will be put forward. Following this idea, an important result will be presented in this article: any continuous piecewise affine function defined over a polytopic partition is the solution of a parametric linear/quadratic programming problem. Furthermore, this convex lifting based method requires at most one supplementary scalar variable. In view of linear model predictive control, it will be shown that any continuous piecewise affine control law can be obtained via a reformulated linear model predictive control problem with the control horizon at most equal to 2 prediction steps.

**Keywords** Convex liftings · Multiparametric convex programming · Inverse optimality · Piecewise affine functions

---

N. A. Nguyen, S. Oлару, P. Rodriguez Ayerbe  
Laboratory of Signals and Systems (L2S, UMR CNRS 8506), CentraleSupélec-CNRS-Université Paris Sud, Gif-sur-Yvette, France. Ngocanh.Nguyen, Sorin.Oлару, Pedro.Rodriguez-Ayerbe@supelec.fr

M. Hovd  
Department of Engineering Cybernetics, Norwegian University of Science and Technologies, Trondheim, Norway. morten.hovd@itk.ntnu.no

I. Necoara  
Politehnica University of Bucharest, Automatic Control and Systems Engineering Department, Bucharest, Romania. ion.necoara@acse.pub.ro

## 1 Introduction

Parametric convex programming (PCP) has attracted significant attention from the control community due to its interesting applications in model predictive control (MPC). A parametric convex programming problem, characterized by a set of linear constraints and a linear/quadratic cost function, is called a parametric linear/quadratic programming problem. It is already known that optimal solution of such a linear/quadratic programming problem is a piecewise affine (PWA) function defined over a polyhedral partition of the parameter space. In control theory, this structure of control laws appeared in the last decade as an approximation of the classical nonlinear control laws with respect to a predefined error [1–4]. Then, it is shown that this PWA structure is inherited by the exact optimal solution of a linear MPC problem with respect to a linear/quadratic cost function [5–10].

Inverse parametric linear/quadratic programming aims to construct a linear constraint set and a linear/quadratic cost function such that the optimal solution of their associated optimization problem is equivalent to a given PWA function, defined over a given polyhedral partition. This inverse optimality problem has been investigated for some years and has resulted in interesting results for the general nonlinear continuous functions [11] and recently for continuous PWA functions [12, 13].

The authors in [11] proved that *every continuous feedback law can be obtained by PCP*. This is an insightful mathematical result; however, it remains pure theoretical; neither a *constructive procedure* nor a qualitative interpretation of the dimension of the optimization arguments is provided. The present work is motivated by a comment therein: *A natural question that can arise from this note would be to particularize our results to piecewise linear controllers: can any continuous piecewise linear feedback law be obtained by parametric linear programming?* The answer is positive and one solution to such an inverse optimality problem is recently found in [12] wherein an indirect solution, built upon a decomposition of a continuous PWA function into the difference of two continuous convex functions, is introduced.

In this paper, we present the results obtained using a different approach: the convex lifting approach. It will be proved that the proposed method can recover the given PWA function with at most one supplementary 1–dimensional variable. The major contributions in this direction are: 1) the introduction of the convex lifting concept for use in the inverse optimality problem; 2) the convex liftability related condition for the existence of a solution of the inverse optimality problem; 3) a constructive procedure based on convex liftings for obtaining a solution of the inverse optimality problem.

The most important result related to Model Predictive Control can be stated as follows: *any continuous piecewise affine control law can be recovered via a linear model predictive control problem with a control horizon at most equal to 2 prediction steps*. The key concept used in the developments: the *lifting* can be defined as an inverse operation of orthogonal projection. As underlined by its definition, this operation allows lifting of a given partition onto a higher dimensional space. In particular, a so-called *convex lifting* of a given partition in  $\mathbb{R}^d$  amounts to a convex surface in  $\mathbb{R}^{d+1}$  such that

- each pair of neighboring regions are lifted onto two distinct hyperplanes and

– its image via the orthogonal projection onto  $\mathbb{R}^d$  coincides with the given partition.

It is worth reminding that the lifting notion was introduced for the first time in Maxwell's research publications e.g. [14] some 150 years ago. Later, a plethora of studies were dedicated for the existence conditions of such a *convex lifting* for a given partition [15–21]. However, most of these results are difficult to apply in numerical methods such as those usually employed in linear control design. Therefore, control theory needs a systematic approach for the use of a lifting procedure in the inverse optimality problem. This aspect will be discussed in details in this paper.

## 2 Notation and Definitions

$\mathbb{R}, \mathbb{R}_+, \mathbb{N}_{>0}$  denote the field of real numbers, the nonnegative real numbers set and the positive integer set, respectively. The following index set is also defined for ease of presentation, with a given  $N \in \mathbb{N}_{>0}$ :  $\mathcal{I}_N = \{i \in \mathbb{N}_{>0} \mid i \leq N\}$ .

A polyhedron is defined as the intersection of finite number of closed halfspaces. A polytope is defined as a bounded polyhedron. Given a full dimensional polytope  $\mathcal{S}$ , then  $\mathcal{V}(\mathcal{S})$  denotes the set of its vertices,  $\text{int}(\mathcal{S})$  denotes its interior.  $\dim(\mathcal{S})$  stands for the dimension of the affine hull of  $\mathcal{S}$ .  $\text{conv}(\mathcal{S})$  denotes the convex hull of a given set  $\mathcal{S}$ . If  $\mathcal{S}$  is an arbitrary set in  $\mathbb{R}^d$  and  $\mathbb{S}$  is a subspace of  $\mathbb{R}^d$ , then  $\text{Proj}_{\mathbb{S}} \mathcal{S}$  represents the orthogonal projection of  $\mathcal{S}$  onto the space  $\mathbb{S}$ . Further, if  $\mathcal{S} \subseteq \mathbb{R}^d$  is a full dimensional polyhedron, a face of  $\mathcal{S}$  is the intersection of  $\mathcal{S}$  and one of its supporting hyperplanes.  $k$ -face represents a face of dimension  $k$ . A 0-face is called a vertex, an 1-face is called an edge, a  $(d-1)$ -face is called a facet. Particularly,  $\emptyset, \mathcal{S}$  are called *improper faces* of polyhedron  $\mathcal{S}$ .  $\mathcal{F}(\mathcal{S})$  denotes the set of all facets of the polyhedron  $\mathcal{S}$ .

For a given  $d \in \mathbb{N}_{>0}$ ,  $0_d$  denotes a vector of dimension  $d$  whose elements are equal to 0. Similarly,  $0_{m \times n}$  denotes a matrix in  $\mathbb{R}^{m \times n}$  composed of the elements equal to 0.

Let us recall also some useful definitions.

**Definition 1** A collection of  $N \in \mathbb{N}_{>0}$  full-dimensional polyhedra  $\mathcal{X}_i \subset \mathbb{R}^d$ , denoted by  $\{\mathcal{X}_i\}_{i \in \mathcal{I}_N}$ , is called a *polyhedral partition of a polyhedron*  $\mathcal{X} \subseteq \mathbb{R}^d$  if:

1.  $\mathcal{X} = \bigcup_{i \in \mathcal{I}_N} \mathcal{X}_i$ ,
2.  $\text{int}(\mathcal{X}_i) \cap \text{int}(\mathcal{X}_j) = \emptyset$  with  $i \neq j$ ,  $(i, j) \in \mathcal{I}_N^2$ .

$(\mathcal{X}_i, \mathcal{X}_j)$  are called neighbours if  $(i, j) \in \mathcal{I}_N^2$ ,  $i \neq j$  and  $\dim(\mathcal{X}_i \cap \mathcal{X}_j) = d-1$ . Also, if  $\mathcal{X}$  is a compact set then  $\{\mathcal{X}_i\}_{i \in \mathcal{I}_N}$  is called *polytopic partition*.

The definition of a *cell complex* was presented by Grünbaum in [22]. For simplicity, a cell complex, in this paper, should be understood as a polyhedral partition whose face-to-face property is fulfilled i.e. any pair of regions share a common face (recall that  $\emptyset$  is also a face of a polyhedron). Accordingly, a polyhedral partition of a polyhedron is a cell complex if any pair of neighboring regions share a common facet.

**Definition 2** For a given polyhedral partition  $\{\mathcal{X}_i\}_{i \in \mathcal{I}_N}$  of a polyhedron  $\mathcal{X} \subseteq \mathbb{R}^d$ , a *piecewise affine lifting* is described by function  $z : \mathcal{X} \rightarrow \mathbb{R}$  with:

$$z(x) = A_i^T x + a_i \quad \text{for any } x \in \mathcal{X}_i, \quad (1)$$

and  $A_i \in \mathbb{R}^d$ ,  $a_i \in \mathbb{R}$ ,  $\forall i \in \mathcal{I}_N$ .

**Definition 3** Given a polyhedral partition  $\{\mathcal{X}_i\}_{i \in \mathcal{I}_N}$  of a polyhedron  $\mathcal{X} \subseteq \mathbb{R}^d$ , a piecewise affine lifting:  $z(x) = A_i^T x + a_i$  for  $x \in \mathcal{X}_i$ , is called *convex piecewise affine lifting* if the following conditions hold true:

- $z(x)$  is continuous over  $\mathcal{X}$ ,
- for each  $i \in \mathcal{I}_N$ ,  $z(x) > A_j^T x + a_j$  for all  $x \in \mathcal{X}_i \setminus \mathcal{X}_j$  and all  $j \neq i$ ,  $j \in \mathcal{I}_N$ .

The second condition in the above definition implies that  $z(x)$  is a convex function defined over  $\mathcal{X}$ . Moreover, the strict inequalities ensure that any pair of neighboring regions are lifted onto two distinct hyperplanes.

For ease of presentation, a slight abuse of notation is used in this paper: a *convex lifting* is understood as a *convex piecewise affine lifting*. From the above definition, if a polyhedral partition  $\{\mathcal{X}_i\}_{i \in \mathcal{I}_N}$  admits a convex lifting, then  $\{\mathcal{X}_i\}_{i \in \mathcal{I}_N}$  has to be a cell complex. This observation is stated by the following proposition.

**Proposition 1** *A polyhedral partition of a polyhedron which admits a convex lifting, is a cell complex.*

*Proof:* Suppose the given polyhedral partition  $\{\mathcal{X}_i\}_{i \in \mathcal{I}_N}$  of a polyhedron  $\mathcal{X} \subseteq \mathbb{R}^d$ , which admits a convex lifting, is not a cell complex. Let  $z(x) = A_i^T x + a_i$  for  $x \in \mathcal{X}_i$  denote this convex lifting of  $\{\mathcal{X}_i\}_{i \in \mathcal{I}_N}$ . Then there exists a pair of neighboring regions, denoted by  $\mathcal{X}_i, \mathcal{X}_j$ , whose facet-to-facet property is not fulfilled.

According to the definition of convex liftings, the hyperplane denoted by  $\mathcal{H}_0$ , containing  $\mathcal{X}_i \cap \mathcal{X}_j$ , can be described by

$$\mathcal{H}_0 = \{x \in \mathbb{R}^d \mid A_i^T x + a_i = A_j^T x + a_j\}.$$

Also, due to the non-satisfaction of the facet-to-facet property, there exists a point, denoted by  $x_0$ , such that  $x_0 \in \mathcal{H}_0 \cap \mathcal{X}_i$  but  $x_0 \notin \mathcal{X}_j$  (an illustration can be found in Fig.1).  $x_0 \in \mathcal{H}_0$  implies  $A_i^T x_0 + a_i = A_j^T x_0 + a_j$ . On the other hand,  $x_0 \in \mathcal{X}_i, x_0 \notin \mathcal{X}_j$  lead to  $A_i^T x_0 + a_i > A_j^T x_0 + a_j$ . These two last inclusions are clearly contradictory. Therefore, the partition  $\{\mathcal{X}_i\}_{i \in \mathcal{I}_N}$  has to be a cell complex.  $\square$

According to this proposition, a convex lifting is always defined over a cell complex. However, the cell complex characterization of  $\{\mathcal{X}_i\}_{i \in \mathcal{I}_N}$  is the necessary condition, but not a sufficient condition for the existence of a convex lifting.

**Definition 4** A given cell complex  $\{\mathcal{X}_i\}_{i \in \mathcal{I}_N}$  in  $\mathbb{R}^d$  has an *affinely equivalent polyhedron* if there exists a polyhedron  $\tilde{\mathcal{X}} \subset \mathbb{R}^{d+1}$  such that for each  $i \in \mathcal{I}_N$ :

1.  $\exists F_i \in \mathcal{F}(\tilde{\mathcal{X}})$  satisfying:  $\text{Proj}_{\mathbb{R}^d} F_i = \mathcal{X}_i$ ,
2. if  $\underline{z}(x) = \min_z z$  s.t.  $[x^T \ z]^T \in \tilde{\mathcal{X}}$ , then  $[x^T \ \underline{z}(x)]^T \in F_i$  for  $x \in \mathcal{X}_i$ .

An illustration can be found in Fig.2 where a cell complex in  $\mathbb{R}$  consists of the multicolored segments along the horizontal axis. One of its affinely equivalent polyhedra in  $\mathbb{R}^2$  is the pink shaded region. Moreover, the lower facets of this polytope are an illustration of the facets  $F_i$  appearing in the definition.

Notice that given a cell complex  $\{\mathcal{X}_i\}_{i \in \mathcal{I}_N}$  of a polyhedron  $\mathcal{X} \subseteq \mathbb{R}^d$ , affinely equivalent to a polyhedron  $\tilde{\mathcal{X}} \subset \mathbb{R}^{d+1}$ , if  $z$  denotes the last coordinate of  $\tilde{\mathcal{X}}$  such that

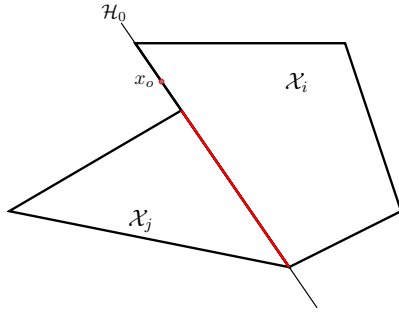

Fig. 1: An illustration for Proposition 1.

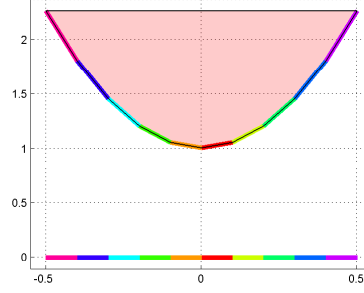

Fig. 2: An illustration of affinely equivalent polyhedron.

$[x^T \ z]^T \in \tilde{\mathcal{X}}$ , then  $\{\mathcal{X}_i\}_{i \in \mathcal{I}_N}$  is nothing other than the cell complex, associated with the optimal solution to the following parametric linear programming problem:

$$z^*(x) = \min_z z \text{ subject to } [x^T \ z]^T \in \tilde{\mathcal{X}}.$$

Also,  $z^*(x)$  represents a convex lifting for this cell complex.

### 3 Problem statement

#### 3.1 Parametric linear/quadratic programming problems

It is already known (see [5–9]) that a parametric linear/quadratic programming problem is defined as follows with respect to  $d_x, d_U \in \mathbb{N}_{>0}$ :

$$\min_U f(U, x) \quad \text{subject to:} \quad GU \leq W + Ex, \quad (2)$$

where  $x \in \mathbb{R}^{d_x}$  represents the parameter vector,  $U \in \mathbb{R}^{d_U}$  represents the decision variable, and  $f(U, x)$  represents a linear/quadratic cost function in  $U$  and  $x$ . The above problem has a continuous solution denoted as  $U^*(x)$  (see [23] and Theorem 4 in [5]), known to be a piecewise affine function defined over a polyhedral partition  $\{\mathcal{X}_i\}_{i \in \mathcal{I}_N}$  of the parameter space denoted as  $\mathcal{X}$ , as a polyhedron:

$$U^*(x) = f_{pwa}(x) = F_i x + G_i, \quad \forall x \in \mathcal{X}_i. \quad (3)$$

Notice that the optimal solution to a parametric quadratic programming problem is unique [5] in case  $f(U, x)$  along  $U$  is strictly convex. It is already known that this uniqueness may no longer be preserved in case of a parametric linear programming problem. However, a continuous selection of optimal solution to such a linear problem is shown in [23] to exist.

Conversely, given a continuous PWA function defined over a polyhedral partition, the question is whether there exists an optimization problem such that its optimal solution is equivalent to the given PWA function. The answer is shown in [11] to be

affirmative, although the numerical construction of such an optimization problem is still open. A possible candidate for this optimization problem may be characterized by a linear/quadratic cost function and a set of linear constraints. For the moment, the definition of an inverse parametric linear/quadratic programming problem is introduced.

### 3.2 Inverse parametric linear/quadratic programming problems

From the mathematical point of view, an inverse parametric linear/quadratic programming problem intends to reconstruct an appropriate optimization problem with respect to a given continuous piecewise affine function  $u(x) = f_{pwa}(x)$ , defined over a given polyhedral partition  $\{\mathcal{X}_i\}_{i \in \mathcal{I}_N}$  of the parameter space  $\mathcal{X} \subseteq \mathbb{R}^{d_x}$ , such that the optimal solution of this reconstructed problem is equivalent<sup>1</sup> to the given PWA function  $f_{pwa}(x)$ . This problem can be briefly stated as follows:

*Problem statement:* For a given polyhedral partition  $\{\mathcal{X}_i\}_{i \in \mathcal{I}_N}$  of the parameter space  $\mathcal{X} \subseteq \mathbb{R}^{d_x}$ , associated with a continuous PWA function  $f_{pwa}(x) : \mathcal{X} \rightarrow \mathbb{R}^{d_u}$ , find a linear/quadratic cost function  $J(x, z, u)$  and matrices  $H_x, H_u, H_z, K$  such that:

$$f_{pwa}(x) = \text{Proj}_{\mathbb{R}^{d_u}} \arg \min_{\begin{bmatrix} z \\ u^T \end{bmatrix}^T} J(x, z, u) \quad \text{s.t.} \quad H_x x + H_z z + H_u u \leq K. \quad (4)$$

As mentioned before, the convex-lifting based solution to such an inverse optimality problem is presented next. A definition of *invertibility* needs to be introduced in order to establish the working assumption of this convex lifting based method.

**Definition 5** A continuous PWA function defined over a polyhedral partition is called *invertible* if there exists an appropriate constraint set and a cost function such that their associated parametric convex programming problem admits the given continuous PWA function as its optimal solution.

## 4 A constructive convex lifting based approach for inverse parametric linear/quadratic programming

### 4.1 Existing results on convex liftings

Many studies dedicated to the existence of convex liftings for the cell complexes in  $\mathbb{R}^2$ , were investigated in [14–16, 20]. These results were then generalized to the cell complexes in the general dimensional space  $\mathbb{R}^d$  through different studies e.g. in [19]. It is shown therein that there exists a convex lifting for a cell complex in  $\mathbb{R}^d$  if and only if one of the followings holds:

- it admits a strictly positive  $d$ –stress,
- it is an additively weighted Dirichlet-Voronoi diagram,

<sup>1</sup> The equivalence hereafter means that the boundary between two regions of the parameter space partition corresponding to two different affine functions, is preserved and a subdivision or refinement of the regions corresponding to the same affine function is admissible.

- it is an additively weighted Delaunay decomposition,
- it is the section of a  $(d + 1)$ -dimensional Dirichlet-Voronoi partition<sup>2</sup>.

The above results cover the general class of cell complexes in  $\mathbb{R}^d$ . Unfortunately, despite the mathematical completeness of the existing results, the verification of these conditions are expensive. Furthermore, they do not provide any hint for the construction of a convex lifting. The next subsection presents such a construction in the general case of cell complexes.

#### 4.2 A construction of convex liftings

In this subsection, the main objective is to present an algorithm for the construction of a convex lifting for a given cell complex via linear/quadratic programming. This algorithm exploits the continuity and the convexity of neighboring regions. Note that we restrict our attention in this article to the polytopic partitions. Construction of convex liftings for cell complexes of an unbounded polyhedron can be found in [27].

Suppose we want to lift a given cell complex  $\{\mathcal{X}_i\}_{i \in \mathcal{I}_N}$  of a polytope  $\mathcal{X} \subset \mathbb{R}^d$ . Let  $\tilde{\mathcal{X}} \subset \mathbb{R}^{d+1}$  be one of its affinely equivalent polyhedra. For each region  $\mathcal{X}_i$ ,  $i \in \mathcal{I}_N$ , the hyperplane, containing the lower facet of  $\tilde{\mathcal{X}}$  whose orthogonal projection onto  $\mathbb{R}^d$  coincides with  $\mathcal{X}_i$ , has the following form:

$$\mathcal{H}_i = \left\{ \begin{bmatrix} x^T & z_i \end{bmatrix}^T \in \mathbb{R}^{d+1} \mid z_i = A_i^T x + a_i, A_i \in \mathbb{R}^d, a_i \in \mathbb{R} \right\}. \quad (5)$$

Let  $(i, j) \in \mathcal{I}_N^2$  be an index pair such that  $(\mathcal{X}_i, \mathcal{X}_j)$  are neighbors. The *continuity conditions* between them are described as follows:

$$\forall x \in \mathcal{X}_i \cap \mathcal{X}_j, i \neq j, z_i(x) = z_j(x). \quad (6)$$

Moreover, the *convexity conditions* between them can be handled as:

$$\forall x \in \mathcal{X}_i \setminus (\mathcal{X}_i \cap \mathcal{X}_j), z_i(x) > z_j(x). \quad (7)$$

Algorithm 1 summarizes the constructive procedure which allows for the computation of the gains  $(A_i, a_i)$ ,  $\forall i \in \mathcal{I}_N$  of a convex lifting. The following theorem serves as an explanation of this algorithm.

**Theorem 1** *If the optimization problem (10) is feasible, then the function  $z(x) = A_i^T x + a_i$  for  $x \in \mathcal{X}_i$  represents a convex lifting for the given cell complex  $\{\mathcal{X}_i\}_{i \in \mathcal{I}_N}$ .*

*Proof:* If the optimization problem (10) is feasible, then the continuity conditions on the function  $z(x)$  and the convexity conditions of its epigraph are all fulfilled. Accordingly, for two neighboring regions  $(\mathcal{X}_i, \mathcal{X}_j)$ , it follows that:

$$\begin{aligned} A_i^T x + a_i &= A_j^T x + a_j \quad \text{for all } x \in \mathcal{X}_i \cap \mathcal{X}_j, \\ A_i^T x + a_i &\geq A_j^T x + a_j + c > A_j^T x + a_j \quad \text{for all } x \in \mathcal{X}_i \setminus \mathcal{X}_j. \end{aligned} \quad (11)$$

<sup>2</sup> Other related results can be found in Konstantin Rybnikov's thesis [19], equally in [18, 24–26]. Note that an additively weighted Dirichlet-Voronoi partition is in fact a generalization of a power diagram.



---

**Algorithm 1** An algorithm for construction of a convex lifting for a given cell complex  $\{\mathcal{X}_i\}_{i \in \mathcal{I}_N}$  of a polytope  $\mathcal{X} \subset \mathbb{R}^d$ .

---

**Input:**  $\{\mathcal{X}_i\}_{i \in \mathcal{I}_N}$  and a given constant  $c > 0$ .

**Output:**  $(A_i, a_i), \forall i \in \mathcal{I}_N$ , an affinely equivalent polyhedron  $\tilde{\mathcal{X}} \subset \mathbb{R}^{d+1}$ .

1: Register all pairs of neighboring regions in  $\{\mathcal{X}_i\}_{i \in \mathcal{I}_N}$ .

2: For each pair of neighboring regions  $(\mathcal{X}_i, \mathcal{X}_j), (i, j) \in \mathcal{I}_N^2$ :

– Add continuity conditions  $\forall v \in \mathcal{V}(\mathcal{X}_i \cap \mathcal{X}_j)$ :

$$A_i^T v + a_i = A_j^T v + a_j. \quad (8)$$

– Add convexity conditions  $\forall u \in \mathcal{V}(\mathcal{X}_i), u \notin \mathcal{V}(\mathcal{X}_j)$ :

$$A_i^T u + a_i \geq A_j^T u + a_j + c. \quad (9)$$

3: Solve the following convex optimization problem by minimizing a chosen cost function e.g.

$$\min_{A_i, a_i} \sum_{i=1}^N (A_i^T A_i + a_i^T a_i) \quad \text{subject to (8), (9)}. \quad (10)$$

4: Construct an affinely equivalent polyhedron

$$\tilde{\mathcal{X}} = \text{conv} \left\{ \left[ v^T \ z(v) \right]^T \in \mathbb{R}^{d+1} \mid v \in \bigcup_{i \in \mathcal{I}_N} \mathcal{V}(\mathcal{X}_i), z(v) = A_i^T v + a_i \text{ if } v \in \mathcal{X}_i \right\}.$$

---

The same inclusion holds for the other pairs of neighboring regions. This leads to the continuity of  $z(x)$  and for each  $i \in \mathcal{I}_N$  :

$$A_i^T x + a_i > A_j^T x + a_j \quad \text{for all } x \in \mathcal{X}_i \setminus \mathcal{X}_j, \forall j \neq i, j \in \mathcal{I}_N. \quad (12)$$

Therefore, function  $z(x) = A_i^T x + a_i$  for  $x \in \mathcal{X}_i$  is a convex lifting defined over the cell complex  $\{\mathcal{X}_i\}_{i \in \mathcal{I}_N}$ , as defined in Definition 3.  $\square$

Note that the cost function chosen in (10) aims to avoid the unboundedness of optimal solution. Other choices of this cost function are possible as long as the boundedness of optimal solution is guaranteed. Also, as seen in (9), the strict convexity condition (7) can be easily transformed into inequality constraints in an optimization problem by adding a positive constant  $c$  on the right-hand side of (9), thus  $>$  can be replaced with  $\geq$ . Theoretically, if the given cell complex is convexly liftable, then any choice of this positive constant does not have any effect on the feasibility of the optimization problem (10). Since, (8) and (9) amount to

$$(\alpha A_i)^T v + (\alpha a_i) = (\alpha A_j)^T v + (\alpha a_j) \quad \text{for } v \in \mathcal{V}(\mathcal{X}_i \cap \mathcal{X}_j)$$

$$(\alpha A_i)^T u + (\alpha a_i) \geq (\alpha A_j)^T u + (\alpha a_j) + \alpha c \quad \text{for } u \in \mathcal{V}(\mathcal{X}_i), u \notin \mathcal{V}(\mathcal{X}_j).$$

In other words,  $\tilde{\ell}(x) = (\alpha A_i)^T x + (\alpha a_i)$  for  $x \in \mathcal{X}_i$  also represents a convex lifting of cell complex  $\{\mathcal{X}_i\}_{i \in \mathcal{I}_N}$  which may be resulted from Algorithm 1 with a given constant  $\alpha c$ . Therefore, the optimization problem (10) is still feasible with the constant  $\alpha c > 0$ . Accordingly, the feasibility of the optimization problem (10) can serve as

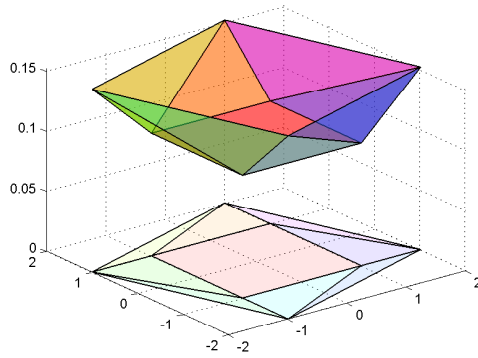

Fig. 3: A cell complex in  $\mathbb{R}^2$  and one of its affinely equivalent polyhedra in  $\mathbb{R}^3$ .

another necessary and sufficient condition for the existence of a convex lifting of a given cell complex. Furthermore, according to Proposition 1, the optimization problem (10) is infeasible for the polytopical partitions of polytopes whose facet-to-facet property is not fulfilled.

To illustrate Algorithm 1, a cell complex in  $\mathbb{R}^2$  is presented in Fig.3. One of its affinely equivalent polyhedra is the shaded polytope with the lower facets multicolored.

#### 4.3 Non-convexly liftable polyhedral partitions

It is already known that the parameter partition, associated with optimal solution to a parametric quadratic programming problem, may not be a cell complex but a polyhedral partition. This case usually takes place in linear model predictive control problems with respect to quadratic cost functions. Therefore, to solve the inverse optimality problem via convex liftings, it is necessary to treat such singular partitions in order that their convex liftability is retrieved. It is shown in [21] that any polyhedral partition can be subdivided into a convexly liftable partition provided its internal boundaries are still preserved. This result is recalled here for completeness.

**Theorem 2** *Given a non-convexly liftable polyhedral partition  $\{\mathcal{X}_i\}_{i \in \mathcal{I}_N}$  of a polyhedron  $\mathcal{X} \subseteq \mathbb{R}^d$ , there exists at least one subdivision, preserving the internal boundaries of this partition, such that the new cell complex is convexly liftable.*

Interested readers can find details about the proof in [21]. According to its proof, the *hyperplane arrangement* technique can be of use to carry out this goal. Practically, hyperplane arrangement is only one way to show the existence of modifications for the given non-convexly liftable polyhedral partition into a convexly liftable cell complex. In control theory, such a modification can increase the complexity of PWA control laws in the implementation. Therefore, such a *complete* refinement may not be necessary in practical applications. Many different refinement techniques exist.

We refer to [28] for an alternative technique for a class of particular cases in control theory.

## 5 Solution to inverse parametric linear/quadratic programming problems

The definition of an inverse parametric linear/quadratic programming problem has been introduced in Subsection 3.2. The solution to such inverse optimality problems is built in this paper upon the convex lifting approach. For the moment, some regularity assumptions need to be stated to make the present approach reasonable from the construction point of view. These assumptions are stated with respect to the notations in Subsection 3.2.

**Assumption 3** *The parametric linear/quadratic programming problems are exclusively considered as possible candidates for solutions to the inverse optimality problem. As a consequence, the cost function has the following form:*

$$J(x, z, u) = [x^T \ z \ u^T] Q \begin{bmatrix} x \\ z \\ u \end{bmatrix} + C^T \begin{bmatrix} x \\ z \\ u \end{bmatrix},$$

with positive semidefinite matrix  $Q^T = Q \geq 0$ .

**Assumption 4** *The polytopic partition  $\{\mathcal{X}_i\}_{i \in \mathcal{I}_N}$ , associated with a given continuous PWA function, is convexly liftable.*

**Assumption 5** *The parameter space  $\mathcal{X} = \bigcup_{i \in \mathcal{I}_N} \mathcal{X}_i$  is a polytope.*

Note that Assumption 3 provides a manageable framework for the constructive inverse optimality procedures. Larger classes of objective functions can provide more degrees of freedom, but the linearity of such parametric convex programming problems is lost. Assumption 5 restricts the inverse optimality problem to bounded feasible region given by a polytope. Since, linear constraints are exclusively of interest. Also, the construction presented below can be easily extended to polyhedral partitions of polyhedra, see [27]. Assumption 4 is not restrictive, since the convex liftability of the given polytopic partition can be enforced by refinement procedures according to Theorem 2. Note also that in the scope of this paper, we restrict our attention to the class of continuous PWA functions. It will be shown that due to this continuity property, the optimal solution to the recovered optimization problem is unique. Inverse optimality for the class of discontinuous PWA functions is studied in [29]. In this case, it is however shown that the uniqueness of optimal solution to the recovered optimization problem is lost.

The following intermediate result is necessary for the development of a constructive solution of the inverse optimality problem.

**Proposition 2** Let  $\Gamma_s \subset \mathbb{R}^{d_s}$  be a polytope with the set of vertices  $\mathcal{V}(\Gamma_s) = \{s^{(1)}, \dots, s^{(q)}\}$ . For any finite set of points  $\{t^{(1)}, \dots, t^{(q)}\} \subset \mathbb{R}^{d_t}$  defining a full-dimensional polytope in  $\mathbb{R}^{d_t}$ , an extension of the family  $\mathcal{V}(\Gamma_s)$  can be obtained in higher dimensional space  $\mathbb{R}^{d_s+d_t}$  for the concatenated vectors  $[s^T \ t^T]^T$  defining the set:

$$V_{[s^T \ t^T]^T} := \left\{ \begin{bmatrix} s^{(1)} \\ t^{(1)} \end{bmatrix}, \dots, \begin{bmatrix} s^{(q)} \\ t^{(q)} \end{bmatrix} \right\}.$$

The polytope  $\Gamma_{[s^T \ t^T]^T} = \text{conv}(V_{[s^T \ t^T]^T})$  satisfies:

$$V_{[s^T \ t^T]^T} = \mathcal{V}(\Gamma_{[s^T \ t^T]^T}).$$

*Proof:* Geometrically, this proposition shows that if  $s^{(i)}$  is a vertex of  $\Gamma_s \subset \mathbb{R}^{d_s}$ , then with any complementary vector  $t^{(i)} \in \mathbb{R}^{d_t}$  leading to an extended vector  $\begin{bmatrix} s^{(i)} \\ t^{(i)} \end{bmatrix} \in \mathbb{R}^{d_s+d_t}$ , this vector represents a vertex of the new polytope  $\Gamma_{[s^T \ t^T]^T}$  in  $\mathbb{R}^{d_s+d_t}$  defined as the convex hull of the extended set of points  $V_{[s^T \ t^T]^T}$ . By construction  $\mathcal{V}(\Gamma_{[s^T \ t^T]^T}) \subseteq V_{[s^T \ t^T]^T}$ . Therefore, in order to prove this claim, we will prove that  $\mathcal{V}(\Gamma_{[s^T \ t^T]^T}) \subset V_{[s^T \ t^T]^T}$  leads to a contradiction.

In fact, suppose  $\mathcal{V}(\Gamma_{[s^T \ t^T]^T}) \subset V_{[s^T \ t^T]^T}$ . According to this assumption, there exists a point in  $V_{[s^T \ t^T]^T}$  which lies in the interior of the polytope  $\Gamma_{[s^T \ t^T]^T}$  or can be described by a convex combination of the other points. Without loss of generality, let  $\begin{bmatrix} s^{(q)} \\ t^{(q)} \end{bmatrix}$  denote this point, then there exists a vector  $\alpha \in \mathbb{R}_+^{q-1}$  such that:

$$\begin{bmatrix} s^{(q)} \\ t^{(q)} \end{bmatrix} = \sum_{i=1}^{q-1} \alpha_i \begin{bmatrix} s^{(i)} \\ t^{(i)} \end{bmatrix}, \quad \sum_{i=1}^{q-1} \alpha_i = 1. \quad (13)$$

One can easily see from (13) that  $s^{(q)}$ , as a vertex of  $\Gamma_s$ , is described by a convex combination of the other vertices of  $\Gamma_s$ . This inclusion is contradictory to the definition of a vertex of a convex set. In other words, all elements of  $V_{[s^T \ t^T]^T}$  are the vertices of  $\Gamma_{[s^T \ t^T]^T}$ .  $\square$

*Remark 1* Note also that this proposition remains valid for the degenerate case where all points  $\{t^{(1)}, \dots, t^{(q)}\}$  are placed on a hyperplane in  $\mathbb{R}^{d_t}$ . However, in this case, the new polytope lies practically in a strict subspace of  $\mathbb{R}^{d_s+d_t}$ . This particular case of values  $t^{(i)}, \forall i \in \mathcal{I}_q$ , is excluded in the previous result as not relevant for the scope of this paper, even though the mathematical result holds.

Consider a given cell complex  $\{\mathcal{X}_i\}_{i \in \mathcal{I}_N}$  of a polytope  $\mathcal{X} \subset \mathbb{R}^{d_x}$  satisfying Assumption 4 and a continuous PWA function  $f_{pwa}(x) : \mathcal{X} \rightarrow \mathbb{R}^{d_u}$  defined over this cell complex. For ease of presentation, let  $\ell(x)$  denote a convex lifting defined over

$\{\mathcal{X}_i\}_{i \in \mathcal{I}_N}$ . Define also the following sets:

$$\begin{aligned} \Pi_{[x^T z]^T} &= \text{conv} \left\{ [v^T \ell(v)]^T \mid v \in \bigcup_{i \in \mathcal{I}_N} \mathcal{V}(\mathcal{X}_i) \right\}, \\ V_{[x^T z \ u^T]^T} &= \left\{ [v^T \ell(v) \ f_{pwa}^T(v)]^T \mid v \in \bigcup_{i \in \mathcal{I}_N} \mathcal{V}(\mathcal{X}_i) \right\}, \\ \Pi_{[x^T z \ u^T]^T} &= \text{conv} \left( V_{[x^T z \ u^T]^T} \right). \end{aligned} \quad (14)$$

With respect to the above notation, the solution to an inverse parametric linear/quadratic programming problem can be stated as follows.

**Theorem 6** *Given a continuous PWA function  $f_{pwa}(x)$  defined over a polytopic partition  $\{\mathcal{X}_i\}_{i \in \mathcal{I}_N}$  satisfying Assumptions 4, 5 and the sets defined in (14), the followings hold true:*

1.  $V_{[x^T z \ u^T]^T} = \mathcal{V}(\Pi_{[x^T z \ u^T]^T})$  and  $\Pi_{[x^T z]^T} = \text{Proj}_{[x^T z]^T} \Pi_{[x^T z \ u^T]^T}$ ,
2. The given PWA function  $f_{pwa}(x)$  is the image via the orthogonal projection onto  $\mathbb{R}^{d_u}$  of the optimal solution to the optimization problem below:

$$\min_{[z \ u^T]^T} z \quad \text{s.t.} \quad [x^T z \ u^T]^T \in \Pi_{[x^T z \ u^T]^T}. \quad (15)$$

*Proof:* 1. The first claim:  $V_{[x^T z \ u^T]^T} = \mathcal{V}(\Pi_{[x^T z \ u^T]^T})$ , is directly deduced from Proposition 2. The second claim follows from the construction of  $\Pi_{[x^T z \ u^T]^T}$  having all its vertices as non-degenerate extended vectors of the vertices of  $\Pi_{[x^T z]^T}$ .

2. It is known that  $\Pi_{[x^T z]^T} \subset \mathbb{R}^{d_x+1}$  represents an affinely equivalent polyhedron of the partition  $\{\mathcal{X}_i\}_{i \in \mathcal{I}_N}$ . Let  $F_{[x^T z]^T}^{(i)}$  for  $i \in \mathcal{I}_N$  denote the lower facet of  $\Pi_{[x^T z]^T}$  such that:  $\text{Proj}_x F_{[x^T z]^T}^{(i)} = \mathcal{X}_i$  and for any  $x \in \mathcal{X}_i$ ,  $[x^T z^*(x)]^T \in F_{[x^T z]^T}^{(i)}$  satisfies

$$z^*(x) = \min_z z \quad \text{s.t.} \quad [x^T z]^T \in \Pi_{[x^T z]^T}.$$

Also, there exists, in higher dimensional space  $\mathbb{R}^{d_x+d_u+1}$ , a  $d_x$ -face denoted as  $F_{[x^T z \ u^T]^T}^{(i)}$  of  $\Pi_{[x^T z \ u^T]^T}$  such that:  $\text{Proj}_{[x^T z]^T} F_{[x^T z \ u^T]^T}^{(i)} = F_{[x^T z]^T}^{(i)}$ . Thus, a point  $[x^T z \ u^T]^T \in \Pi_{[x^T z \ u^T]^T}$  satisfying  $x \in \mathcal{X}_i$  has the minimal value of  $z$  if and only if this point locates on  $F_{[x^T z \ u^T]^T}^{(i)}$ . It is worth stressing that the face  $F_{[x^T z \ u^T]^T}^{(i)}$  is defined as follows:

$$F_{[x^T z \ u^T]^T}^{(i)} = \text{conv} \left\{ [v^T \ell(v) \ f_{pwa}^T(v)]^T \mid v \in \mathcal{V}(\mathcal{X}_i) \right\}.$$

From the above argument, it follows that there exist non-negative scalars  $\alpha(v) \in \mathbb{R}_+$ , for  $v \in \mathcal{V}(\mathcal{X}_i)$  such that:

$$\begin{aligned} \sum_{v \in \mathcal{V}(\mathcal{X}_i)} \alpha(v) &= 1, \\ [x^T z^*(x) \ (u^*)^T(x)]^T &= \sum_{v \in \mathcal{V}(\mathcal{X}_i)} \alpha(v) [v^T \ell(v) \ f_{pwa}^T(v)]^T. \end{aligned}$$

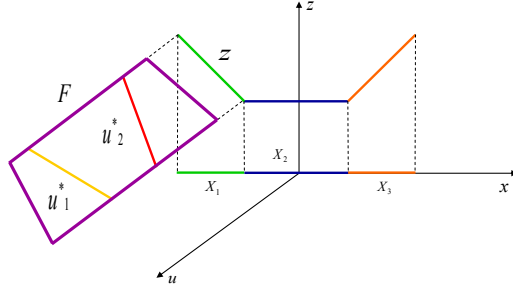

Fig. 4: An illustration of two different optimal solutions.

Since this property holds for all elements of  $\mathcal{X}_i$ , it can be deduced that:

$$\begin{bmatrix} z^*(x) \\ u^*(x) \end{bmatrix} = \sum_{v \in \mathcal{V}(\mathcal{X}_i)} \alpha(v) \begin{bmatrix} \ell(v) \\ f_{pwa}(v) \end{bmatrix} = \begin{bmatrix} \ell(x) \\ f_{pwa}(x) \end{bmatrix}, \quad \forall x \in \mathcal{X}_i.$$

Clearly,  $f_{pwa}(x)$  is a sub-component of this optimal solution.

To complete the proof, the uniqueness of such an optimal solution needs to be clarified. Suppose there exist two different optimal solutions to (15):

$$\begin{aligned} \begin{bmatrix} z_1^*(x) \\ u_1^*(x) \end{bmatrix} &= \arg \min_{\begin{bmatrix} z \\ u \end{bmatrix}} z, \quad \text{s.t.} \quad \begin{bmatrix} x^T & z & u^T \end{bmatrix}^T \in \Pi_{\begin{bmatrix} x^T & z & u^T \end{bmatrix}^T}, \\ \begin{bmatrix} z_2^*(x) \\ u_2^*(x) \end{bmatrix} &= \arg \min_{\begin{bmatrix} z \\ u \end{bmatrix}} z, \quad \text{s.t.} \quad \begin{bmatrix} x^T & z & u^T \end{bmatrix}^T \in \Pi_{\begin{bmatrix} x^T & z & u^T \end{bmatrix}^T}, \end{aligned}$$

then it is clear that  $z_1^*(x) = z_2^*(x) = \ell(x)$ . Accordingly, if  $u_1^*(x) \neq u_2^*(x)$  for  $x \in \mathcal{X}_i$ , there exists a  $(d_x + 1)$ -face denoted as  $F$  of  $\Pi_{\begin{bmatrix} x^T & z & u^T \end{bmatrix}^T}$  (illustrated in Fig.4) to which two optimal solutions  $\begin{bmatrix} z_1^*(x) \\ u_1^*(x) \end{bmatrix}^T$  and  $\begin{bmatrix} z_2^*(x) \\ u_2^*(x) \end{bmatrix}^T$  belong such that  $F$  is perpendicular to the space  $\begin{bmatrix} x^T & z \end{bmatrix}^T$ . This implies that the value of  $f_{pwa}(v)$  is not uniquely defined for vertices  $v \in \mathcal{V}(\mathcal{X}_i)$ . This consequence contradicts the construction of the constraint set  $\Pi_{\begin{bmatrix} x^T & z & u^T \end{bmatrix}^T}$  presented in (14). Therefore, such two optimal solutions have to be identical, leading to the uniqueness.  $\square$

The constructive procedure towards recovering a continuous PWA function defined over a convexly liftable polytopical partition is summarized through Algorithm 2.

Theorem 6 proves the existence of an optimization problem with respect to a linear cost function which has as a sub-component of the optimal solution, a given PWA function defined over a convexly liftable polytopical partition. The following theorem shows the existence of equivalent optimization problem with respect to a *quadratic cost function*.

**Theorem 7** Consider a continuous PWA function  $f_{pwa}(x)$  defined over a polytopical partition  $\{\mathcal{X}_i\}_{i \in \mathcal{I}_N}$  satisfying Assumptions 4, 5 and the sets defined in (14). Function

---

**Algorithm 2** Linear equivalent optimization problem
 

---

**Input:** A continuous PWA function  $f_{pwa}(x)$  defined over a convexly liftable polytopic partition  $\{\mathcal{X}_i\}_{i \in \mathcal{I}_N}$  of a polytope  $\mathcal{X} \subset \mathbb{R}^{d_x}$ .

**Output:**  $\Pi_{[x^T \ z \ u^T]^T}$  and  $J(x, z, u)$ .

- 1: Construct a convex lifting  $\ell(x)$  for  $\{\mathcal{X}_i\}_{i \in \mathcal{I}_N}$  via Algorithm 1.
- 2: Compute  $\Pi_{[x^T \ z \ u^T]^T}$  as in (14).
- 3: Define  $J(x, z, u) = z$ .
- 4: Solve the following parametric linear programming problem:

$$\left[ z^*(x) \ (u^*)^T(x) \right]^T = \arg \min_{\left[ z \ u^T \right]^T} z \quad \text{subject to} \quad \left[ x^T \ z \ u^T \right]^T \in \Pi_{[x^T \ z \ u^T]^T}.$$

- 5: Obtain the given PWA function:  $\text{Proj}_u \begin{bmatrix} z^*(x) \\ u^*(x) \end{bmatrix} = f_{pwa}(x)$ .
- 

$f_{pwa}(x)$  is the image via the orthogonal projection onto  $\mathbb{R}^{d_u}$  of the optimal solution to the following optimization problem:

$$\min_{\left[ z \ u^T \right]^T} (z - \sigma(x))^2 \quad \text{s.t.} \quad \left[ x^T \ z \ u^T \right]^T \in \Pi_{[x^T \ z \ u^T]^T}, \quad (16)$$

where  $\sigma(x) : \mathcal{X} \rightarrow \mathbb{R}$  denotes any function satisfying:  $\sigma(x) \leq \ell(x)$ .

*Proof:* Consider an affinely equivalent polyhedron  $\Pi_{[x^T \ z]^T}$  defined as in (14). According to its definition, we obtain:

$$\ell(x) = \min_z z \quad \text{subject to} \quad \left[ x^T \ z \right]^T \in \Pi_{[x^T \ z]^T}.$$

Therefore, for any function  $\sigma(x) : \mathcal{X} \rightarrow \mathbb{R}$  satisfying  $\sigma(x) \leq \ell(x)$ , the minimization of  $(z - \sigma(x))^2$  amounts to the minimization of  $z$  subject to the same set of constraints  $\Pi_{[x^T \ z \ u^T]^T}$ . According to Theorem 6, the given continuous PWA function  $f_{pwa}(x)$  is a sub-component of the optimal solution to (15) as well as (16).  $\square$

Algorithm 3 summarizes the constructive procedure of an equivalent optimization problem with respect to a quadratic cost function.

*Remark 2* Theorem 7 proposes a generic quadratic cost function of  $\left[ z \ u^T \right]^T$ . If the goal is to obtain a quadratic cost function of  $\left[ x^T \ z \ u^T \right]^T$ , then function  $\sigma(x)$  should be chosen as an affine function of  $x$ .

We will present in the sequel the important properties of the solution to IPL/QP problems via convex liftings i.e. the *invertibility* and the *complexity* of the above constructive inverse optimality procedures.

**Theorem 8 (Invertibility)** *Given a polytopic partition  $\{\mathcal{X}_i\}_{i \in \mathcal{I}_N}$  of a polytope  $\mathcal{X} \subset \mathbb{R}^{d_x}$ , then any continuous PWA function  $f_{pwa}(x) : \mathcal{X} \rightarrow \mathbb{R}^{d_u}$ , defined over  $\{\mathcal{X}_i\}_{i \in \mathcal{I}_N}$ , is invertible.*

---

<sup>3</sup> One can choose  $\sigma(x)$  to be an affine function composing  $\ell(x)$ .

**Algorithm 3** Quadratic equivalent optimization problem

**Input:** A continuous PWA function  $f_{pwa}(x)$  defined over a convexly liftable polytopic partition  $\{\mathcal{X}_i\}_{i \in \mathcal{I}_N}$  of a polytope  $\mathcal{X} \subset \mathbb{R}^{d_x}$ .

**Output:**  $\Pi_{[x^T \ z \ u^T]^T}$  and  $J(x, z, u)$ .

- 1: Construct a convex lifting  $\ell(x)$  for  $\{\mathcal{X}_i\}_{i \in \mathcal{I}_N}$  via Algorithm 1.
- 2: Compute  $\Pi_{[x^T \ z \ u^T]^T}$  as in (14).
- 3: Choose a function<sup>3</sup>  $\sigma(x) : \mathcal{X} \rightarrow \mathbb{R}$  such that  $\sigma(x) \leq \ell(x)$ .
- 4: Define  $J(x, z, u) = (z - \sigma(x))^2$ .
- 5: Solve the following parametric quadratic programming problem:

$$\begin{bmatrix} z^*(x) \\ (u^*)^T(x) \end{bmatrix}^T = \arg \min_{\begin{bmatrix} z \\ u^T \end{bmatrix}^T} (z - \sigma(x))^2 \quad \text{s.t.} \quad \begin{bmatrix} x^T & z & u^T \end{bmatrix}^T \in \Pi_{[x^T \ z \ u^T]^T}.$$

- 6: Project the optimal solution onto  $\mathbb{R}^{d_u} : \text{Proj}_u \begin{bmatrix} z^*(x) \\ u^*(x) \end{bmatrix} = f_{pwa}(x)$ .

*Proof:* If  $\{\mathcal{X}_i\}_{i \in \mathcal{I}_N}$  admits an affinely equivalent polyhedron, then Theorems 6 and 7 show a formulation of such an inverse parametric linear/quadratic programming problem. In case the convex liftable of  $\{\mathcal{X}_i\}_{i \in \mathcal{I}_N}$  is not fulfilled, according to Theorem 2,  $\{\mathcal{X}_i\}_{i \in \mathcal{I}_N}$  can be subdivided into a convexly liftable cell complex such that the internal boundaries are maintained.  $f_{pwa}(x)$  is replaced with an equivalent PWA function corresponding to this new convexly liftable cell complex. With these preconditionings, the problem is recast to recover a continuous PWA function defined over a convexly liftable cell complex.  $\square$

The complexity of an inverse parametric linear/quadratic programming problem based on convex liftings is also stated as follows:

**Theorem 9 (Complexity)** *Any continuous PWA function defined over a polytopic partition of a polytope can be equivalently obtained by a parametric linear/quadratic programming problem with at most one auxiliary 1–dimensional variable.*

*Proof:* Let  $\{\mathcal{X}_i\}_{i \in \mathcal{I}_N}$  denote this given polytopic partition of a polytope  $\mathcal{X}$ . If  $\{\mathcal{X}_i\}_{i \in \mathcal{I}_N}$  is convexly liftable, this 1–dimensional variable describes the convex lifting in the recovered optimization problem. Theorems 6, 7 show that this PWA function is invertible through the convex lifting based approach.

Otherwise, in case the given partition is not convexly liftable, Theorem 2 shows that there exists at least one way to subdivide the given non-convexly liftable polytopic partition into a convexly liftable cell complex, denoted by  $\{\tilde{\mathcal{X}}_i\}_{i \in \mathcal{I}_{\tilde{N}}}$ , meanwhile the internal boundaries are maintained. According to this subdivision, the given PWA function  $f_{pwa}(x)$  is also subdivided. This new PWA function, say  $\tilde{f}_{pwa}(x)$ , is equivalent to  $f_{pwa}(x)$  and defined over a convexly liftable cell complex  $\{\tilde{\mathcal{X}}_i\}_{i \in \mathcal{I}_{\tilde{N}}}$ .

Therefore, similar to the first case, a convex lifting of  $\{\tilde{\mathcal{X}}_i\}_{i \in \mathcal{I}_{\tilde{N}}}$ , represents the 1–dimensional auxiliary variable. Also, as proved in Theorems 6, 7,  $\tilde{f}_{pwa}(x)$ , associated with  $\{\tilde{\mathcal{X}}_i\}_{i \in \mathcal{I}_{\tilde{N}}}$ , is invertible via the convex lifting based method.  $\square$



## 6 Applications to linear MPC problems

The classical model predictive control problem aims to minimize a cost function over a finite prediction horizon  $N \in \mathbb{N}_{>0}$ :

$$F(U, x_k) = \sum_{i=0}^{N-1} \ell_i(x_{k+i|k}, u_{k+i|k}) + V_N(x_{k+N|k}), \quad (17)$$

where  $x_{k+i|k} \in \mathbb{R}^{d_x}$ ,  $u_{k+i|k} \in \mathbb{R}^{d_u}$  are the state variable, control variable, respectively, at time  $k+i$ , predicted at time  $k$  and

$$U = \left[ u_{k|k}^T \cdots u_{k+N-1|k}^T \right]^T.$$

$\ell_i(x_{k+i|k}, u_{k+i|k})$  represents a stage cost  $\forall i \in \mathcal{I}_{N-1} \cup \{0\}$  and  $V_N(x_{k+N|k})$  denotes a terminal cost function.

In case of linear model predictive control, this optimization problem is solved in the presence of constraints:

$$\begin{aligned} H_x^{(i)} x_{k+i|k} + H_u^{(i)} u_{k+i|k} &\leq k^{(i)}, \quad \forall i \in \mathcal{I}_{N-1} \cup \{0\}, \\ H_x^{(N)} x_{k+N|k} &\leq k^{(N)}, \end{aligned} \quad (18)$$

where the matrices  $H_x^{(i)}$ ,  $H_u^{(i)}$ ,  $k^{(i)}$  describe mixed state and input constraints for each stage of prediction horizon.

In addition, in the linear MPC literature,  $\ell_i(x_{k+i|k}, u_{k+i|k}) \forall i \in \mathcal{I}_{N-1} \cup \{0\}$  and  $V_N(x_{k+N|k})$  have one of the following forms:

1. quadratic stage cost and terminal cost  $\ell_i(x_{k+i|k}, u_{k+i|k}) = x_{k+i|k}^T Q_i x_{k+i|k} + u_{k+i|k}^T R_i u_{k+i|k}$ ,  $V_N(x_{k+N|k}) = x_{k+N|k}^T P x_{k+N|k}$ ,
2.  $1/\infty$ -norm stage cost and terminal cost  $\ell_i(x_{k+i|k}, u_{k+i|k}) = \|Q_i x_{k+i|k}\|_p + \|R_i u_{k+i|k}\|_p$ ,  $V_N(x_{k+N|k}) = \|P x_{k+N|k}\|_p$ ,

where  $P, Q_i \in \mathbb{R}^{d_x \times d_x}$ , are symmetric and positive semidefinite,  $R_i \in \mathbb{R}^{d_u \times d_u}$  is symmetric and positive definite in case of 2-norm, otherwise, in case  $p = 1/\infty$ -norms,  $P, Q_i, R_i$  are matrices of appropriate dimension.

These linear MPC problems can be formulated in a compact way [9, 30] as parametric linear/quadratic programming problems defined already in Subsection 3.1. Their solution can be written in the following form:

$$U^*(x) = \arg \min_U F(U, x_k) \text{ s.t. } GU \leq W + Ex_k, \quad (19)$$

where the control input sequence  $U$  represents the decision variable and the current state  $x_k$  stands for the parameter. In implementation, the interest of this optimal solution is restricted to the first part:  $u_k = \text{Proj}_{\mathbb{R}^{d_u}} U^*(x)$ ; it also inherits the piecewise affine structure. Therefore, a continuous explicit solution to a linear MPC problem also inherits the properties of an inverse optimality problem shown above. The main message of this paper is stated in the following theorem.

**Theorem 10** *Any continuous PWA control law can be equivalently obtained through a linear MPC problem with a linear or quadratic cost function and the control horizon at most equal to 2 prediction steps.*

*Proof:* Let  $u(x) : \mathbb{R}^{d_x} \rightarrow \mathbb{R}^{d_u}$  denote a continuous optimal control law to a linear MPC problem, defined over a state space partition  $\{\mathcal{X}_i\}_{i \in \mathcal{I}_N}$  of a polytope  $\mathcal{X} \subset \mathbb{R}^{d_x}$ . If  $\{\mathcal{X}_i\}_{i \in \mathcal{I}_N}$  is not convexly liftable, it can be subdivided into a convexly liftable cell complex according to Theorem 2. Therefore, one can exclusively focus on the case  $\{\mathcal{X}_i\}_{i \in \mathcal{I}_N}$  is convexly liftable.

Now, let  $\Pi_{[x_k^T \ z \ u_k^T]^T}$  denote the set of constraints in the recovered optimization problem i.e.

$$\min_{\begin{bmatrix} z \\ u_k^T \end{bmatrix}^T} z \quad \text{s.t.} \quad \begin{bmatrix} x_k^T & z & u_k^T \end{bmatrix}^T \in \Pi_{[x_k^T \ z \ u_k^T]^T}. \quad (20)$$

For ease of presentation, let  $\Pi_{[x_k^T \ z \ u_k^T]^T}$  be given in the following form:

$$H_x x_k + H_z z + H_u u_k \leq K.$$

If  $d_u = 1$ , then it suffices to use  $z$  as the second predicted control law i.e.  $u_{k+1|k} = z$ . Otherwise, the set of constraints  $H_x x_k + H_u u_k + H_z z \leq K$  amounts to the following constraints:

$$H_x x_k + H_u u_k + [H_z \ 0] \begin{bmatrix} z \\ s \end{bmatrix} \leq K,$$

where  $0$  denotes a matrix of appropriate dimension, composed of zeros with the number of columns equal to  $d_u - 1$ . Also,  $s \in \mathbb{R}^{d_u - 1}$  denotes auxiliary variable. Again, apply  $\begin{bmatrix} z \\ s \end{bmatrix}$  for the next predicted control variable i.e.  $u_{k+1|k} = \begin{bmatrix} z \\ s \end{bmatrix}$ . Accordingly, (20) can be written as follows:

$$\min_{\begin{bmatrix} u_k^T & u_{k+1|k}^T \end{bmatrix}^T} \begin{bmatrix} 0_{d_u}^T & 1 & 0_{d_u-1}^T \end{bmatrix} \begin{bmatrix} u_k \\ u_{k+1|k} \end{bmatrix} \quad \text{s.t.} \quad H_x x_k + [H_u \ H_z \ 0] \begin{bmatrix} u_k \\ u_{k+1|k} \end{bmatrix} \leq K,$$

known to be a linear MPC problem with respect to a linear cost function.

On the other hand, according to Theorem 7, the recovered optimization problem with a quadratic cost function can also be written in the following form:

$$\min_{\begin{bmatrix} z \\ u_k^T \end{bmatrix}^T} (z - \sigma(x_k))^2 \quad \text{s.t.} \quad \begin{bmatrix} x_k^T & z & u_k^T \end{bmatrix}^T \in \Pi_{[x_k^T \ z \ u_k^T]^T}, \quad (21)$$

where  $\sigma(x_k) \leq \ell(x_k)$ ,  $\ell(x_k)$  denotes the convex lifting for the given cell complex  $\{\mathcal{X}_i\}_{i \in \mathcal{I}_N}$ , used to compute  $\Pi_{[x_k^T \ z \ u_k^T]^T}$ . Suppose  $\ell(x_k) = A_i^T x_k + a_i$  for  $x_k \in \mathcal{X}_i$ , it suffices to choose  $\sigma(x_k) = A_i^T x_k + a_i$  over  $\mathcal{X}$ . Accordingly, similar to the case of linear MPC with a linear cost function, (21) can be easily written in the form of a linear MPC problem with respect to a quadratic function of  $\begin{bmatrix} u_k^T & u_{k+1|k}^T \end{bmatrix}^T$ . The proof is complete.  $\square$

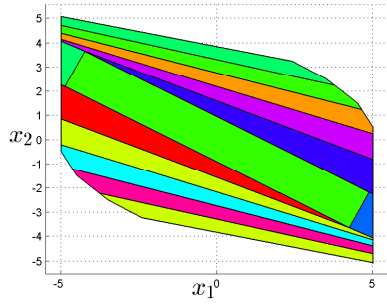

Fig. 5: A convexly liftable cell complex  $\{\mathcal{X}_i\}_{i \in \mathcal{I}_{13}}$  of the state space  $\mathcal{X}$ .

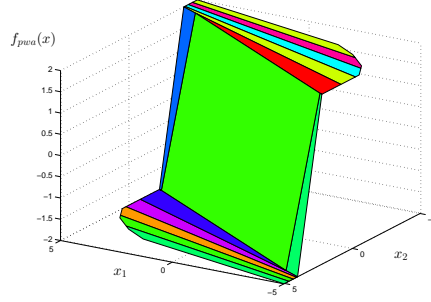

Fig. 6: The piecewise affine controller to recover.

## 7 Illustrative examples

This section considers numerical examples to illustrate the above results.

### 7.1 $\{\mathcal{X}_i\}_{i \in \mathcal{I}_N}$ is a convexly liftable cell complex

This example is induced from a double integrator system:

$$\begin{aligned} x_{k+1} &= \begin{bmatrix} 1 & 0.5 \\ 0 & 1 \end{bmatrix} x_k + \begin{bmatrix} 0.125 \\ 0.5 \end{bmatrix} u_k \\ y_k &= [1 \ 0] x_k \end{aligned} \quad (22)$$

An MPC problem, constructed with the minimization of a quadratic cost function over a prediction horizon  $N = 5$ , is presented as follows, with respect to weighting matrices  $Q = \begin{bmatrix} 10 & 0 \\ 0 & 10 \end{bmatrix}$ ,  $R = 0.5$ :

$$J = \sum_{i=0}^4 (x_{k+i|k}^T Q x_{k+i|k}^T + u_{k+i|k}^T R u_{k+i|k}) + x_{k+5|k}^T P x_{k+5|k},$$

where  $P$  is computed via the Riccati equation.

Constraints on the present control variable and output signal are given by:  $u_k \in [-2, 2]$  and  $y_k \in [-5, 5]$ . The terminal constraint is chosen as the maximal output admissible set as shown in [31]. The feedback control law is depicted in Fig.6; its associated partition  $\{\mathcal{X}_i\}_{i \in \mathcal{I}_{13}}$  is showed in Fig.5. A convex lifting for the state space cell complex  $\{\mathcal{X}_i\}_{i \in \mathcal{I}_{13}}$  is shown in Fig.7. Finally, the result of parametric linear programming problem constructed via Algorithm 2 is shown in Fig.8. It can be observed that the results in Fig.8 and Fig.6 are identical.

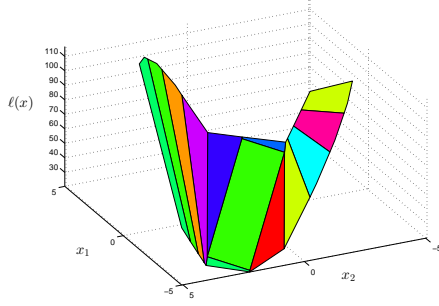

Fig. 7: A convex lifting for the cell complex of the state space in Fig.5.

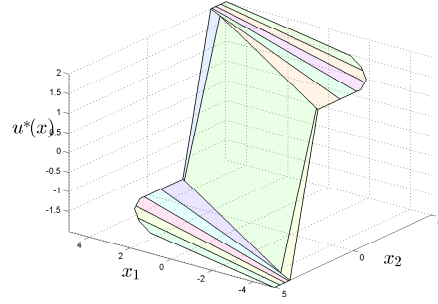

Fig. 8: Recovered PWA control law via Algorithm 2.

7.2  $\{\mathcal{X}_i\}_{i \in \mathcal{I}_N}$  is a polytopical partition inherited from an arbitrary parametric quadratic programming problem

To illustrate a case in which the given polytopical partition is not convexly liftable, consider example 1 presented in [32]:

$$\begin{aligned} & \min_x x^T x \quad \text{s.t. } x \in \mathcal{P}(\theta), \theta \in \Theta, \\ & \Theta = \left\{ \theta \in \mathbb{R}^2 \mid -\frac{3}{2} \leq \theta_i \leq \frac{3}{2}, i = 1, 2 \right\}. \\ & \mathcal{P}(\theta) = \left\{ x \in \mathbb{R}^3 \mid \begin{array}{l} x_1 - x_3 \leq -1 + \theta_1, \quad -x_1 - x_3 \leq -1 - \theta_1 \\ x_2 - x_3 \leq -1 - \theta_2, \quad -x_2 - x_3 \leq -1 + \theta_2 \\ \frac{3}{4}x_1 + \frac{16}{25}x_2 - x_3 \leq -1 + \theta_1 \\ -\frac{3}{4}x_1 - \frac{16}{25}x_2 - x_3 \leq -1 - \theta_1 \end{array} \right\}. \end{aligned}$$

The parameter space partition is shown in Fig.9 to be a polytopical partition but not a cell complex. Its associated continuous PWA function is presented in Fig.10. It is clear that this polytopical partition is not convexly liftable. One can also confirm this observation via the infeasibility of the optimization problem (10). This requires a subdivision into a convexly liftable cell complex. A subdivision of this partition into a convexly liftable cell complex can be found in Fig.11. One of its convex liftings is shown in Fig.12. Further, a continuous PWA function equivalent to the one shown in Fig.10, is presented in Fig.13, as a sub-component of the optimal solution to the recovered optimization problem via Algorithm 2.

## 8 Conclusions

This article presents a method to solve inverse parametric linear/quadratic programming problems. This method relies on convex lifting. It is shown that for any con-

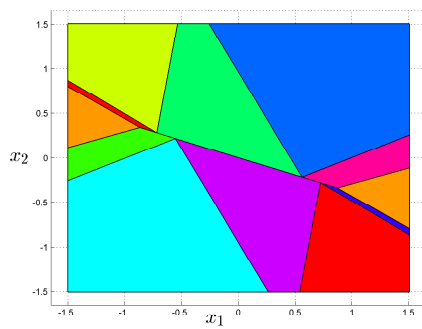

Fig. 9: A polytopic partition of the parameter space.

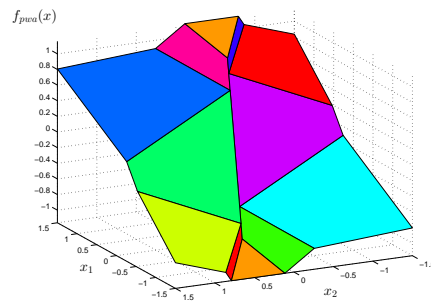

Fig. 10: A continuous PWA function associated with the polytopic partition in Fig.9

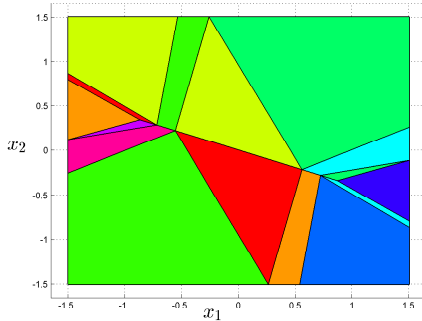

Fig. 11: A subdivision of the polytopic partition in Fig.9 into a convex liftable cell complex.

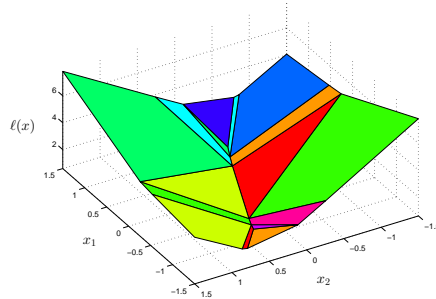

Fig. 12: A convex lifting for the cell complex in Fig.11.

tinuous PWA function defined over a polytopic partition, an appropriate equivalence of this function can be obtained by another parametric linear/quadratic programming problem with a supplementary variable of dimension equal to 1. In view of linear MPC, it has been shown that any continuous PWA control law can be obtained via another MPC problem with the prediction horizon equal to 2 prediction steps. The same statement can be reformulated as: *any linear MPC formulation has an equivalent MPC formulation with two steps of the prediction horizon*. Several numerical examples prove the effectiveness of this method.

## References

1. Johansen, T.A.: On multi-parametric nonlinear programming and explicit nonlinear model predictive control. In: Decision and Control, Proceedings of the 41st IEEE Conference on, vol. 3, pp. 2768–2773 (2002)

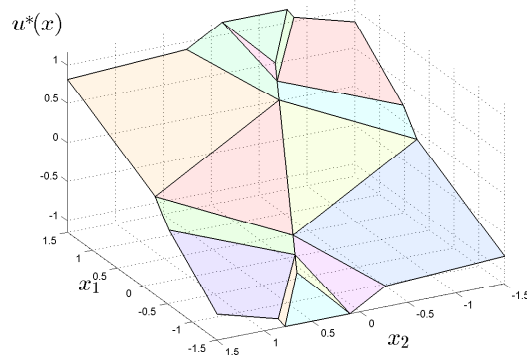

Fig. 13: A continuous PWA function equivalent to the one shown in Fig.10, resulted from Algorithm 2.

2. Johansen, T.A.: Approximate explicit receding horizon control of constrained nonlinear systems. *Automatica* **40**(2), 293 – 300 (2004)
3. Bemporad, A., Filippi, C.: An algorithm for approximate multiparametric convex programming. *Computational optimization and applications* **35**(1), 87–108 (2006)
4. Grancharova, A., Johansen, T.A.: *Explicit Nonlinear Model Predictive Control*. Springer (2012)
5. Bemporad, A., Morari, M., Dua, V., Pistikopoulos, E.N.: The explicit linear quadratic regulator for constrained systems. *Automatica* **38**(1), 3–20 (2002)
6. Tøndel, P., Johansen, T.A., Bemporad, A.: An algorithm for multi-parametric quadratic programming and explicit mpc solutions. *Automatica* **39**(3), 489–497 (2003)
7. Seron, M.M., Goodwin, G.C., Doná, J.A.: Characterisation of receding horizon control for constrained linear systems. *Asian Journal of Control* **5**(2), 271–286 (2003)
8. Olaru, S., Dumur, D.: A parameterized polyhedra approach for explicit constrained predictive control. In: *Decision and Control, 43rd IEEE Conference on*, vol. 2, pp. 1580–1585 (2004)
9. Pistikopoulos, E.N., Georgiadis, M.C., Dua, V.: *Multi-parametric programming*. Wiley-vch (2007)
10. Feller, C., Johansen, T.A., Olaru, S.: An improved algorithm for combinatorial multi-parametric quadratic programming. *Automatica* **49**(5), 1370–1376 (2013)
11. Baes, M., Diehl, M., Necoara, I.: Every continuous nonlinear control system can be obtained by parametric convex programming. *IEEE tran on Automatic Control* **53**(8), 1963–1967 (2008)
12. Hempel, A., Goulart, P., Lygeros, J.: On inverse parametric optimization with an application to hybrid system control. *Automatic Control, IEEE Transactions on* **60**(4), 1064–1069 (2015)
13. Nguyen, N.A., Olaru, S., Rodriguez-Ayerbe, P., Hovd, M., Necoara, I.: Inverse parametric convex programming problems via convex liftings. In: *19th IFAC World Congress, Cape Town, South Africa* (2014)
14. Maxwell, J.C.: On reciprocal diagrams and diagrams of forces. *Philosophical Magazine ser. 4*, **27**, 250–261 (1864)
15. Crapo, H., Whiteley, W.: Plane self stresses and projected polyhedra 1: the basic pattern. *Structural Topology* **19**, 55–73 (1993)
16. Crapo, H., Whiteley, W.: Spaces of stresses, projections and parallel drawings for spherical polyhedra. *Contributions to Algebra and Geometry* **35**(So. 2), 259–281 (1994)
17. Aurenhammer, F.: Recognising polytopical cell complexes and constructing projection polyhedra. *Journal of Symbolic Computation* **3**, 249–255 (1987)
18. Aurenhammer, F.: Criterion for the affine equivalence of cell complexes in  $r^d$  and convex polyhedra in  $r^{d+1}$ . *Discrete and Computational Geometry* **2**, 49–64 (1987)
19. Rybnikov, K.: *Polyhedral partitions and stresses*. Ph.D. thesis, Queen University, Kingston, Ontario, Canada (1999)

20. Schulz, A.: Lifting planar graphs to realize integral 3-polytopes and topics in pseudo-triangulations. Ph.D. thesis, Fachbereich Mathematik und Informatik der Freien Universität Berlin (2008)
21. Nguyen, N.A., Oлару, S., Rodriguez-Ayerbe, P., Hovd, M., Necoara, I.: On the lifting problems and their connections with piecewise affine control design. In: European Control Conference, Strasbourg, France (2014)
22. Grünbaum, B.: Convex polytopes. Wiley Interscience (1967)
23. Oлару, S., Dumur, D.: On the continuity and complexity of control laws based on multiparametric linear programs. In: Decision and Control, 45th Conference on, pp. 5465–5470. IEEE (2006)
24. Aurenhammer, F.: Voronoi diagrams: A survey of a fundamental data structure. *ACM Comput. Surveys* **23**, 345–405 (1991)
25. Aurenhammer, F.: Power diagrams: properties, algorithms and applications. *SIAM Journal on Computing* **16**(1), 78–96 (1987)
26. Nguyen, N.A., Oлару, S., Rodriguez-Ayerbe, P.: Recognition of additively weighted voronoi diagrams and weighted delaunay decompositions. In: European Control Conference, Linz, Austria (2015)
27. Nguyen, N.A., Oлару, S., Rodriguez-Ayerbe, P.: Inverse parametric linear/quadratic programming problem for continuous pwa functions defined on polyhedral partitions of polyhedra. In: 54th IEEE Conference on Decision and Control, Osaka, Japan (2015)
28. Gulan, M., Nguyen, N.A., Oлару, S., Rodriguez-Ayerbe, P., Rohal’-Ilkiv, B.: Implications of inverse parametric optimization in model predictive control. In: S. Oлару, A. Grancharova, F.L. Pereira (eds.) *Developments in Model-Based Optimization and Control*. Springer (2015)
29. Nguyen, N.A., Oлару, S., Rodriguez-Ayerbe, P.: Any discontinuous pwa function is optimal solution to a parametric linear programming problem. In: 54th IEEE Conference on Decision and Control, Osaka, Japan (2015)
30. Pistikopoulos, E.: Perspectives in multiparametric programming and explicit model predictive control. *AIChE journal* **55**(8), 1918–1925 (2009)
31. Gilbert, E.G., Tan, K.T.: Linear systems with state and control constraints: The theory and application of maximal output admissible sets. *IEEE Transactions on Automatic Control* **36**(9), 1008:1020 (1991)
32. Spjøtvold, J., Kerrigan, E.C., Jones, C.N., Tøndel, P., Johansen, T.A.: On the facet-to-facet property of solutions to convex parametric quadratic programs. *Automatica* **42**(12), 2209–2214 (2006)