



HAL
open science

A Low Complexity Iterative Soft Detection for Bit Interleaved Coded CPM

Malek Messai, Karine Amis Cavalec, Frédéric Guilloud

► **To cite this version:**

Malek Messai, Karine Amis Cavalec, Frédéric Guilloud. A Low Complexity Iterative Soft Detection for Bit Interleaved Coded CPM. ISTC 2014: proceedings of the 8th International Symposium on Turbo Codes and Iterative Information Processing, Aug 2014, Bremen, Germany. pp.12-16, 10.1109/ISTC.2014.6955076 . hal-01188813

HAL Id: hal-01188813

<https://hal.science/hal-01188813v1>

Submitted on 27 May 2022

HAL is a multi-disciplinary open access archive for the deposit and dissemination of scientific research documents, whether they are published or not. The documents may come from teaching and research institutions in France or abroad, or from public or private research centers.

L'archive ouverte pluridisciplinaire **HAL**, est destinée au dépôt et à la diffusion de documents scientifiques de niveau recherche, publiés ou non, émanant des établissements d'enseignement et de recherche français ou étrangers, des laboratoires publics ou privés.



Distributed under a Creative Commons Attribution - NonCommercial 4.0 International License

A Low Complexity Iterative Soft Detection for Bit Interleaved Coded CPM

MESSAI Malek, AMIS Karine and GUILLOUD Frédéric
Institut Télécom; Télécom Bretagne; UMR CNRS 3192 Lab-STICC
Technopôle Brest Iroise CS 83818 29238 Brest, France
Université européenne de Bretagne
Email: Firstname.Lastname@telecom-bretagne.eu

Abstract—In this paper, we propose a low-complexity iterative soft detection algorithm for a bit interleaved coded continuous phase modulation (CPM). The reduction of complexity is obtained by using a modulation index at the receiver side which is different from the one used at the transmitter side. This difference is balanced thanks to a soft-input soft-output (SISO) coherent CPM demodulator based on the per survivor processing (PSP) technique. Compared to the state of the art, the error rate performance is improved. We also show that our algorithm converges close to the coherent maximum a posteriori (MAP) algorithm, with a few additional iterations.

I. INTRODUCTION

Continuous phase modulations (CPM) are constant envelope modulations known for their high power and spectral efficiency but also robustness to nonlinearities [1]. CPM are also well suited for serial concatenation with a forward error correction (FEC) code via an interleaver which allows to achieve the near Shannon-limit performance with the use of iterative demodulation/decoding [2], [3], [4].

Recently, several soft-input soft-output (SISO) noncoherent detection algorithms suitable for iterative detection/decoding have been designed for CPM modulations transmitted over channels affected by time varying phase (see for example [5], [6] and [7]). These techniques are based on a joint demodulation and phase estimation. The non coherent iterative detection makes itself an attractive strategy in practice for its robustness to phase noise (PN). On the other hand, optimal detection, which minimizes the symbol error probability is achieved by *maximum a posteriori* (MAP) symbol decision. By using a probabilistic derivation based on the chain rule of a Markov source properties, the MAP symbol detection algorithm is efficiently implemented by using the Bahl, Cocke, Jelinek and Raviv (BCJR) algorithm [8].

The MAP symbol detection strategy relies on the trellis state description of the CPM which can be implemented only when the modulation index is a rational number of the form $\frac{k}{p}$, where k and p are relative prime integers. Recently, the per survivor processing (PSP) [9] has been applied in [10] to soft-in soft-out (SISO) CPFSK detection with an irrational modulation index. The low cost of the CPM transmitters could lead to an irrational modulation index rather than the desired rational one or a rational modulation index with large denominator [11] which involves a high receiver complexity.

The reduction of complexity is generally obtained by reducing the number of trellis states and/or the number of matched filters (MF). Huber and Liu [12] have been concerned with obtaining a set of basis function which can be used in the place of MFs. The detector uses only a limited number of these basis functions in order to reduce complexity. In this paper, we focus on the decrease of complexity based on a lower number of trellis states. A reduced state number trellis is built by using a rational modulation index denoted by h_{rx} with a small denominator. The low complexity receiver takes into account the difference between the transmission and the reception modulation indices. In [10], the PSP is only applied to a specific case (binary full-response CPFSK). Moreover, the bit interleaved coded CPFSK (BIC-CPFSK) receiver developed in [10] doesn't take into account the extrinsic APPs (*a posteriori* probability) on both information symbols and coded symbols which degrades the performance.

The contributions of this paper compared to [10] are two-fold. First, we extend the PSP-SISO principle to the M -ary partial response CPM signals. Second, we propose an enhanced BIC-CPM receiver by taking into account the extrinsic APPs. By adjusting the parameters and considering the extrinsic information, the proposed algorithm can achieve near optimal performance with lower complexity. The paper is organized as follows: we first briefly introduce the system model in Section II. Then we define the generalized PSP based SISO CPM demodulation in Section III. We give some simulation results in Section IV and present conclusions in Section V.

II. SYSTEM MODEL

A. Signal model

The BIC-CPM system model considered in this paper is shown in Fig. 1. The transmitted bits, $\mathbf{b} = \{b_n\}$, are encoded using a convolutional channel encoder. Then, the coded bits $\mathbf{c} = \{c_n\}$ are interleaved and mapped to an M -ary alphabet $\{\pm 1, \pm 3, \dots, \pm(M-1)\}$ denoted by $\mathbf{a} = \{a_n\}$. The resulting symbols are then used to generate the complex envelope $s(t, \mathbf{a})$ of the CPM signal:

$$s(t, \mathbf{a}) = \sqrt{\frac{E}{T}} e^{j\phi(t, \mathbf{a})}, \quad (1)$$

where E is the average symbol energy, T is the symbol

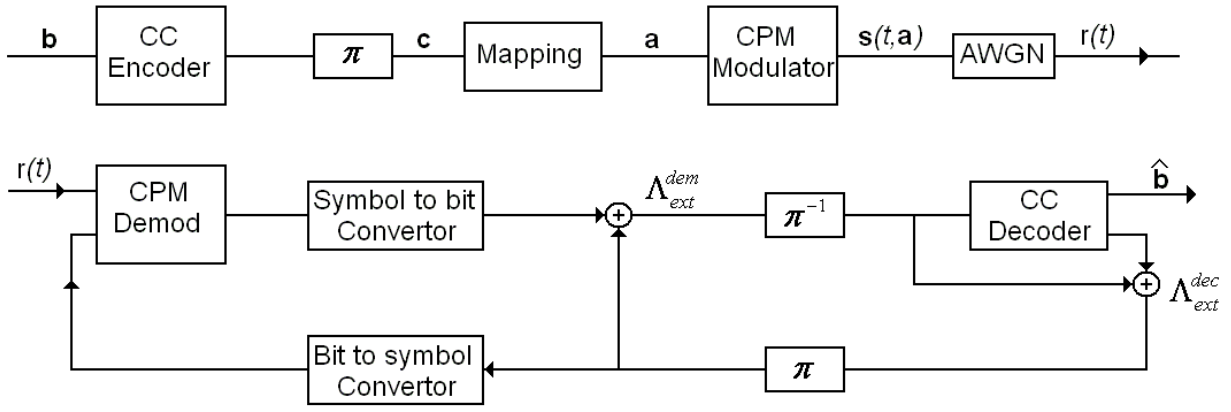

Fig. 1. System model.

duration and $\phi(t, \mathbf{a})$ the information-carrying phase given by:

$$\phi(t, \mathbf{a}) = 2\pi h_{tx} \sum_{i=0}^{N-1} a_i q(t - iT). \quad (2)$$

The function $q(t)$ is the phase response and its derivative is the frequency pulse $g(t)$ of duration LT , which satisfies the two following conditions:

$$\begin{aligned} g(t) &= g(LT - t), \\ \int_0^t g(\tau) d\tau &= q(LT) = \frac{1}{2}, \quad t \geq LT. \end{aligned} \quad (3)$$

Using this, we can rewrite (2) during the n -th time interval as: $t \in [nT, (n+1)T)$, $n \in \mathbb{N}$:

$$\begin{aligned} \phi(t, \mathbf{a}) &= 2\pi h_{tx} \sum_{i=0}^{\infty} a_i q(t - iT), \\ &= \pi h_{tx} \sum_{i=0}^{n-L} a_i + 2\pi h_{tx} \sum_{i=n-L+1}^n a_i q(t - iT), \\ &= \theta_{tx,n} + \phi_{tx,n}(t). \end{aligned} \quad (4)$$

From (4), it is obvious that the modulated signal over the n -th interval depends both on the phase state denoted by $\theta_{tx,n}$ and on the L most recent symbols, i.e. $(a_{n-L+1}, \dots, a_{n-1}, a_n)$. For a rational modulation index $h_{tx} = \frac{k_{tx}}{p_{tx}}$, the phase state $\theta_{tx,n}$ modulo 2π can take only p_{tx} or $2p_{tx}$ different values according to the parity, respectively even or odd, of the numerator of the modulation index denoted by k_{tx} . Therefore, the phase evolution can be described by a finite state machine, where each state is represented by an L -dimensional vector

$$\mathbf{x}_n = (\theta_{tx,n}, a_{n-L+1}, \dots, a_{n-2}, a_{n-1}) \quad (5)$$

So, the CPM signal can be regarded as a recursive convolutional code with memoryless length L and code rate 1, followed by a memoryless phase modulator [13]. Consequently, the number of such states in the CPM trellis denoted by N_s is $p_{tx} M^{L-1}$.

B. MAP symbol coherent detection of CPM signals

We assume that the signal is transmitted over a Gaussian channel. The equivalent baseband received signal, denoted by $r(t)$, is defined as:

$$r(t) = s(t, \mathbf{a}) + w(t), \quad (6)$$

where $w(t)$ is a complex-valued additive white Gaussian noise (AWGN) process with independent components, each with two-sided power spectral density N_0 and zero mean.

Optimal detection, which minimizes the symbol error probability is achieved by *maximum a posteriori* (MAP) symbol decision of the information symbol a_n [14]. The corresponding symbol-by-symbol MAP detector maximizes the *a posteriori* probability (APP) $p(a_n | \mathbf{r})$:

$$\hat{a}_n = \arg \max_a p(a_n = a | \mathbf{r}) \quad (7)$$

Using the definition of \mathbf{x}_n given in (5), we can express the conditional probability of (7) as

$$p(a_n = a | \mathbf{r}) = \sum_{\mathbf{x}_{n+1} | a_n = a} p(\mathbf{x}_{n+1} | \mathbf{r}) \quad (8)$$

Based on to the BCJR algorithm [8], we associate to each node in the trellis the corresponding APP $p(\mathbf{x}_n | \mathbf{r})$ and associate to each branch in the trellis the corresponding $p(\mathbf{x}_{n-1}, \mathbf{x}_n | \mathbf{r})$,

$$\begin{aligned} \lambda_n(\mathbf{x}_n) &= p(\mathbf{x}_n | \mathbf{r}), \\ &= p(\mathbf{x}_n | \mathbf{r}_0^{n-1}) \cdot p(\mathbf{r}_n^N | \mathbf{x}_n, \mathbf{r}_0^{n-1}), \\ &= p(\mathbf{x}_n | \mathbf{r}_0^{n-1}) \cdot p(\mathbf{r}_n^N | \mathbf{x}_n), \\ &= \alpha_n(\mathbf{x}_n) \beta_n(\mathbf{x}_n), \end{aligned} \quad (9)$$

where \mathbf{r}_0^n is the received signal until the end of the n -th time interval. $\alpha_n(\mathbf{x}_n)$ and $\beta_n(\mathbf{x}_n)$ denote the forward-accumulated and backward-accumulated metrics, respectively and are recursively computed as

$$\alpha_n(\mathbf{x}_n) = \sum_{\mathbf{x}_{n-1}} \alpha_n(\mathbf{x}_{n-1}) \gamma_n(\mathbf{x}_{n-1}, \mathbf{x}_n), \quad (10)$$

and

$$\beta(\mathbf{x}_n) = \sum_{\mathbf{x}_{n+1}} \beta_n(\mathbf{x}_{n+1}) \gamma_n(\mathbf{x}_n, \mathbf{x}_{n+1}), \quad (11)$$

where the branch metric $\gamma_n(\mathbf{x}_n, \mathbf{x}_{n+1})$ is defined as:

$$\begin{aligned} \gamma_n(\mathbf{x}_n, \mathbf{x}_{n+1}) &= p(\mathbf{x}_n, \mathbf{r}_n | \mathbf{x}_{n-1}) \\ &= p(\mathbf{r}_n | \mathbf{x}_n, \mathbf{x}_{n-1}) p(\mathbf{x}_n | \mathbf{x}_{n-1}) \\ &= \frac{1}{2\pi N_0} e^{-\frac{1}{2N_0} \int_{(n-1)T}^{nT} |r(t) - s(t, \alpha)|^2 dt} \cdot p(\mathbf{x}_n | \mathbf{x}_{n-1}) \\ &\propto e^{\frac{1}{N_0} \int_{(n-1)T}^{nT} r(t) s^*(t, \alpha) dt} \cdot p(\mathbf{x}_n | \mathbf{x}_{n-1}). \end{aligned} \quad (12)$$

As α and β are calculated iteratively, we need just to initialize $\alpha(\mathbf{x}_0) = 1$ and $\beta(\mathbf{x}_N) = \frac{1}{N_s}$.

III. PROPOSED RECEIVER

The proposed receiver relies on the decomposition of h_{tx} in the form $h_{rx} + \Delta h$ with h_{rx} being a rational number. The key idea is to use the BCJR algorithm with modified branch and state metrics on a trellis designed upon h_{rx} . It takes into account a phase difference proportional to Δh and computed on a PSP basis [9].

Going back to the information-carrying phase expression given in (5), we express it as a function of h_{rx} and Δh :

$$\phi(t, \mathbf{a}) = \theta_{rx,n} + \phi_{rx,n}(t) + \Delta\theta_n + 2\pi\Delta h \sum_{i=n-L+1}^n a_i q(t-iT). \quad (13)$$

$\Delta\theta_n$ is the phase difference which is built up at every symbol. We propose to build a trellis at the receiver based on h_{rx} and we modify the state description by adding one parameter. For each state $\mathbf{x}_n^i (\theta_{rx}^i, a_{n-L+1}^i, \dots, a_{n-1}^i)$ at the time index n , we store $\Delta\theta_n^i$. Its computation will be precised later on. The proposed modified BCJR algorithm can be described as follows. We first carry out a forward recursion to compute α_n according to (10) where the branch metric between states \mathbf{x}_n^j and \mathbf{x}_{n+1}^i is modified as follows:

$$\begin{aligned} \gamma_n(\mathbf{x}_n, \mathbf{x}_{n+1}) &\propto \exp\left(\int_{(n-1)T}^{nT} r(t)\right) \\ &e^{-j(\theta_{rx,n} + \Delta\theta_n^i + 2\pi(h_{rx} + \Delta h) \sum_{i=n-L+1}^n a_i q(t-iT)) dt} \cdot p(\mathbf{x}_n | \mathbf{x}_{n-1}) \end{aligned} \quad (14)$$

To calculate the term $\gamma_n(\mathbf{x}_n, \mathbf{x}_{n+1})$, we need to know $\Delta\theta_n^i$ at each state. We propose to compute $\Delta\theta_n^i$ recursively using the PSP technique:

$$\Delta\theta_n^i = \Delta\theta_{n-1}^j + \pi a_{n-L+1}^j \Delta h \quad (15)$$

where $j = \arg \max_k \{\alpha_n(\mathbf{x}_{n-1}^k) \gamma_n(\mathbf{x}_{n-1}^k, \mathbf{x}_n^i)\}$. and a_{n-L}^j is the second coefficient of the definition of \mathbf{x}_{n-1}^j (see (5)).

In the reduced-state number trellis, it is necessary to keep track of the survivor associated to each transition at each epoch only in the forward recursion of α_n . Then, these survivors are used in the backward recursion of β_n [15]. It means that the value of transition $\gamma_n(\mathbf{x}_n, \mathbf{x}_{n+1})$ will be saved during the forward recursion to be used in the backward recursion. The proposed algorithm is summarized thereafter:

The Proposed Algorithm

- Step 1: Initialization ($n = 0$)
 $\Delta\theta_n^i = 0$ for all states \mathbf{x}_n^i
 if $\mathbf{x}_n = \mathbf{x}^0$ $\alpha_0(\mathbf{x}^0) = 1$ otherwise $\alpha_0(\mathbf{x}_n) = 0$
- Step 2: Forward Recursion $n : 1 \rightarrow N$
 Calculate for all possible transitions $\mathbf{x}_{n-1}^j \rightarrow \mathbf{x}_n^i$ the branch metrics $\gamma_n(\mathbf{x}^j, \mathbf{x}^i)$ according to (14).
 The forward-accumulated metric is calculated using (10) $\alpha_n(\mathbf{x}_n) = \sum_{\mathbf{x}_{n-1}} \alpha_{n-1}(\mathbf{x}_{n-1}) \gamma_n(\mathbf{x}_{n-1}, \mathbf{x}_n)$. Then, for \mathbf{x}_n^i , update $\Delta\theta_n^i$ according to (15)
- Step 3 : Backward Recursion $n : N - 1 \rightarrow 0$
 Initialize $\beta_N = \frac{1}{N_s}$ for all states.
 Update backward-accumulated metric β_n according to (11)

IV. SIMULATIONS

This section provides numerical results to analyze the performance of the proposed iterative BIC-CPM demodulation algorithm on an AWGN channel. In all simulations we use a binary convolutional code defined by its polynomials (7,5) in octal and a pseudo-random interleaver. Performances of the proposed BIC-CPM algorithm are evaluated in terms of BER versus E_b/N_0 , where E_b is the received average signal energy per information bit.

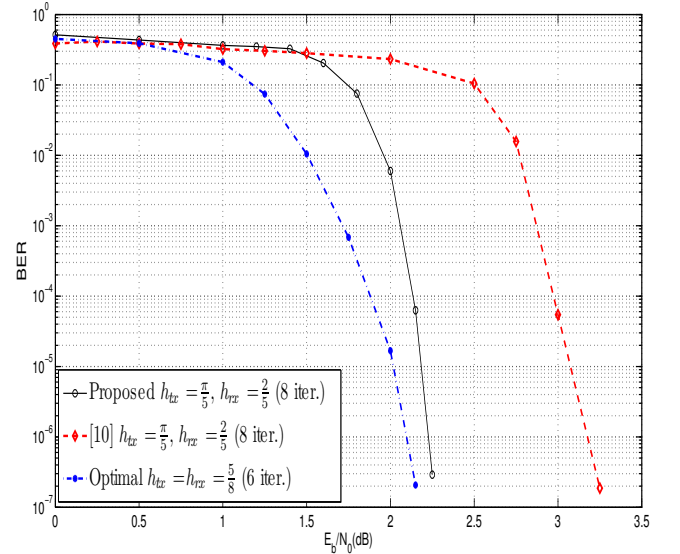

Fig. 2. BER Performance of the Proposed receiver compared with the Optimal coherent SISO detection for a CPFSK modulation with $h_{tx} = \frac{\pi}{5}$, CC(7,5) and pseudo-random interleaver length equal to 8192. The number of iterations required to reach convergence is given in brackets.

In Fig. 2, the same parameters as in [10] are taken, namely a CPFSK modulation with an irrational transmission modulation index of $\frac{\pi}{5}$. We aim to show the improvements of performance compared to [10] when we take into account the extrinsic APPs information. As an optimal coherent detection for an

irrational modulation index is not feasible with the MAP algorithm, our solution allows us to overcome this limitation, by using a trellis constructed with $h_{rx} = \frac{2}{5}$. The BER performance is compared first with the optimal MAP coherent detection of a CPFSK transmission with a rational modulation index of $h_{tx} = h_{rx} = \frac{5}{8}$ which is very close to the irrational modulation index mentioned above. It is shown from Fig. 2 that our proposed iterative BIC-CPM algorithm with a random interleaver of length 8192 converges after 8 iterations and performs close to the near optimum coherent MAP detection for $h_{tx} = h_{rx} = \frac{5}{8}$ that converges after only 6 iterations. A complexity reduction is however achieved as the trellis based on $h_{rx} = \frac{2}{5}$ consists of 5 phase states compared to 16 in the case of $\frac{5}{8}$. Compared to [10], we observe that considering the extrinsic APPs information in the detection allows to have a gain of 1.1 dB at $BER = 10^{-5}$.

The second example is a partial response CPM where the transmission modulation index is taken rational to have an exact comparison with the optimal one. In Fig. 3, we consider a binary GMSK modulation with $L = 3$. A pseudo-random interleaver of size 2048 is taken. A detection with the proposed receiver with $h_{rx} = \frac{2}{3}$ yields to have 12 states in the received trellis. However, the optimum detection requires a trellis of 16 states. The convergence of the proposed algorithm is achieved at the 12th iteration while for the optimal MAP detection it's achieved after 9 iterations. We also see that for a BER of 10^{-5} , compared to the optimum MAP receiver, the performance loss is around 0.1 dB. Compared to the receiver that uses the principle of [10], we observe a gain of 1 dB for a BER of 10^{-5} .

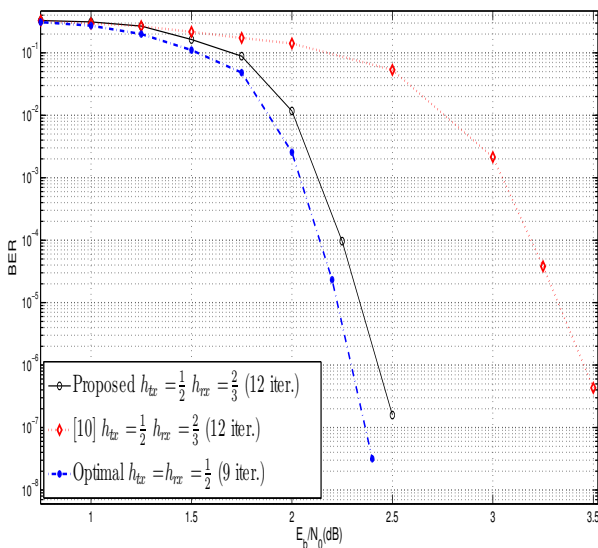

Fig. 3. BER Performance of the Proposed receiver for a binary GMSK modulation with $BT = 0.4$, $L = 3$, CC(7,5) and pseudo-random interleaver length equal to 2048. The number of iterations required to reach convergence is given in brackets.

In Fig. 4, we present the simulations of Quaternary ($M=4$)

CPM with raised-cosine frequency pulse where the transmission modulation index $h_{tx} = \frac{1}{4}$. A pseudo-random interleaver of size 4096 is employed. The reception modulation index is chosen empirically, it has been found that $h_{rx} = \frac{2}{5}$ gives a good compromise between performance and complexity. A trellis built with $h_{rx} = \frac{2}{5}$ has 20 states and allows to have near optimum performance after 10 iterations with a loss of 0.1 dB at $BER = 10^{-5}$. However, the use of $h_{rx} = \frac{2}{3}$ at the receiver side allows to have a trellis with only 12 states but a higher BER degradation is obtained. For the optimum coherent MAP, the trellis has 32 states and the convergence occurs after only 8 iterations. Compared to the receiver that uses the principle of [10], we observe a gain of 1 dB for a BER of 10^{-5} .

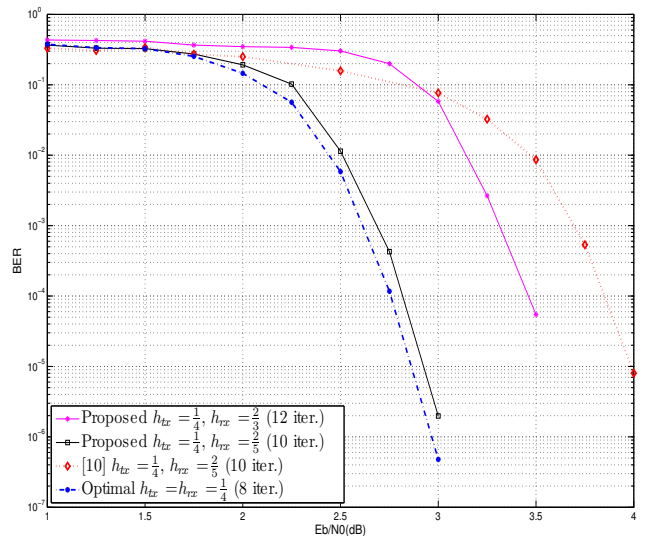

Fig. 4. BER Performance of the Proposed receiver for a quaternary RC modulation with $L = 2$ and $h_{tx} = \frac{1}{4}$, CC(7,5) and pseudo-random interleaver length equal to 4096. The number of iterations required to reach convergence is given in brackets.

V. CONCLUSION

In this paper, we proposed a low complexity iterative coherent detection algorithm for BIC-CPM. By using the PSP approach, a reduced-state number trellis with lower complexity compared with the optimal coherent detection one is constructed. Simulations carried out for different CPMs have shown that the proposed receiver achieves near optimal performance. Our approach can be also combined with all the complexity reduction techniques where a trellis structure is used.

REFERENCES

- [1] J. Anderson, T. Aulin, and C. Sundberg, *Digital Phase Modulation*. Springer, 1986.
- [2] M. Xiao and T. M. Aulin, "Serially concatenated continuous phase modulation with convolutional codes over rings," *Communications, IEEE Transactions on*, vol. 54, no. 8, pp. 1387–1396, Aug 2006.

- [3] P. Moqvist and T. M. Aulin, "Serially concatenated continuous phase modulation with iterative decoding," *Communications, IEEE Transactions on*, vol. 49, no. 11, pp. 1901–1915, Nov 2001.
- [4] A. Graell i Amat, C. Nour, and C. Douillard, "Serially concatenated continuous phase modulation for satellite communications," *Wireless Communications, IEEE Transactions on*, vol. 8, no. 6, pp. 3260–3269, June 2009.
- [5] Q. Zhao, H. Kim, and G. Stuber, "Innovations-based MAP estimation with application to phase synchronization for serially concatenated cpm," *Wireless Communications, IEEE Transactions on*, vol. 5, no. 5, pp. 1033–1043, May 2006.
- [6] A. Barbieri and G. Colavolpe, "Simplified soft-output detection of CPM signals over coherent and phase noise channels," *Wireless Communications, IEEE Transactions on*, vol. 6, no. 7, pp. 2486–2496, July 2007.
- [7] N. Noels, M. Moeneclaey, F. Simoons, and D. Delaruelle, "A low-complexity iterative phase noise tracker for bit-interleaved coded CPM signals in AWGN," *Signal Processing, IEEE Transactions on*, vol. 59, no. 9, pp. 4271–4285, Sept 2011.
- [8] L. Bahl, J. Cocke, F. Jelinek, and J. Raviv, "Optimal decoding of linear codes for minimizing symbol error rate (corresp.)," *Information Theory, IEEE Transactions on*, vol. 20, no. 2, pp. 284–287, Mar 1974.
- [9] R. Raheli, A. Polydoros, and C.-K. Tzou, "Per-survivor processing: a general approach to mlse in uncertain environments," *Communications, IEEE Transactions on*, vol. 43, no. 234, pp. 354–364, Feb 1995.
- [10] S. Zarei, W. Gerstacker, G. Kilian, and W. Koch, "An iterative detection algorithm for coded CPFSK signals with irrational modulation index," in *Signal Processing Conference (EUSIPCO), 2012 Proceedings of the 20th European*, Aug 2012, pp. 2541–2545.
- [11] M. Speth, M. Madden, M. Hammes, and A. Neubauer, "MLSE based detection for GFSK signals with arbitrary modulation index," in *Communications, 2004 International Zurich Seminar on*, 2004, pp. 228–231.
- [12] J. Huber and W. Liu, "An alternative approach to reduced-complexity CPM-receivers," *Selected Areas in Communications, IEEE Journal on*, vol. 7, no. 9, pp. 1437–1449, Dec 1989.
- [13] B. Rimoldi, "A decomposition approach to CPM," *Information Theory, IEEE Transactions on*, vol. 34, no. 2, pp. 260–270, Mar 1988.
- [14] P. A. Murphy, G. E. Ford, and M. Golanbari, "MAP symbol detection of CPM bursts," in *IN PROC. 7TH VIRGINIA TECH. SYMP. ON WIRELESS PERS. COMM*, 1997.
- [15] G. Colavolpe, G. Ferrari, and R. Raheli, "Reduced-state BCJR-type algorithms," *Selected Areas in Communications, IEEE Journal on*, vol. 19, no. 5, pp. 848–859, May 2001.