



HAL
open science

Induction Motors Energy Optimized Control Strategy by Means of Phaseback Voltage Control

Mohamed Benbouzid

► **To cite this version:**

Mohamed Benbouzid. Induction Motors Energy Optimized Control Strategy by Means of Phaseback Voltage Control. *Electromotion*, 1997, 4 (4), pp.165-169. hal-01184274

HAL Id: hal-01184274

<https://hal.science/hal-01184274>

Submitted on 13 Aug 2015

HAL is a multi-disciplinary open access archive for the deposit and dissemination of scientific research documents, whether they are published or not. The documents may come from teaching and research institutions in France or abroad, or from public or private research centers.

L'archive ouverte pluridisciplinaire **HAL**, est destinée au dépôt et à la diffusion de documents scientifiques de niveau recherche, publiés ou non, émanant des établissements d'enseignement et de recherche français ou étrangers, des laboratoires publics ou privés.

Induction Motors Energy Optimized Control Strategy by Means of Phaseback Voltage Control

M.E.H. Benbouzid

A method for improving the efficiency of a slightly loaded induction motor is suggested. It is based upon the optimal-efficiency power factor tracking by adjusting the input voltage. It has adopted the triac-converter fed induction motor drive system. All the control loops are implemented by the Intel 8754 microprocessor. By this method, 10% or more improvement is obtained at a quarter of the full load.

1. Introduction

A great quantity of electrical power has been consumed as an energy source by electrical or mechanical facilities. Sixty percent of their total consumption is for electrical rotary machine drives. Especially, among different types of electrical motors, the induction motors has a lot of inherent advantages for industrial applications. Therefore, about 80 percent of all motors, by the virtue of their merit, are induction motors [1]. Thus, it is very important to improve their efficiency for energy savings.

In general, an induction motor is designed to maintain high efficiency when it is driven in the region of 75 percent to the full load. However, not all the motors are always driven under these circumstances. Hence, as the load factor becomes low, the efficiency of an induction motor can be substantially improved by controlling the voltage V [2].

This paper proposes a real-time microprocessor-based energy optimized control strategy for a variable input voltage three-phase induction motor. Although limited to those applications where the motor duty cycle includes substantial periods of operation at light load, the concept is applicable to both fixed and variable frequency inverter drivers. This paper will be concerned primarily with fixed frequency three-phase drives. It experimentally explored the concept of voltage control using the motor power factor as the primary independent control variable.

2. Control algorithm

In a conventional drive system, the induction motor is driven under constant V . There is only one torque-speed curve which meets a load torque curve at a given reference speed. Thus, the power factor is fixed. However, if the

induction motor is driven under variable V , there are many torque-speed curves which meet a load torque curve at a given reference speed. Therefore, each power factor is different.

It is well known that the efficiency of an induction motor is widely varied with power factor. It can be easily verified that the maximum-efficiency (optimal-efficiency) power factor, which can be calculated from the equivalent circuit of an induction motor shown in Fig. 1, is constant at a particular speed regardless of load condition.

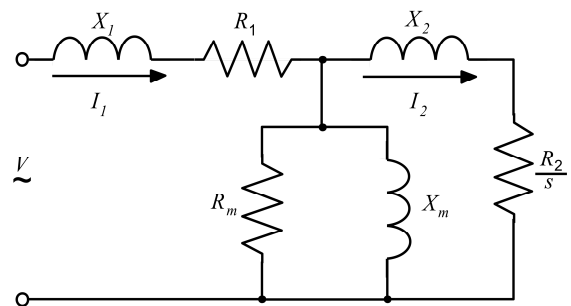

Fig. 1. Conventional per phase equivalent circuit.

As a starting point, the power factor has been chosen as a primary independent control variable because it is always lagging and set by external quantities. So, if an automatic voltage controller is used to maintain the power factor constant at some optimum value, the efficiency remains not only constant but also optimum. The development of microprocessor-based control techniques provides new implementation means for sophisticated efficiency-improvement control strategies for electric motors. Such controls appear to be especially effective when applied to

induction motors, in which the energy dissipated in the motor strongly depends on the load profile. The principle of such

type of automatic system is proposed in Fig. 2.

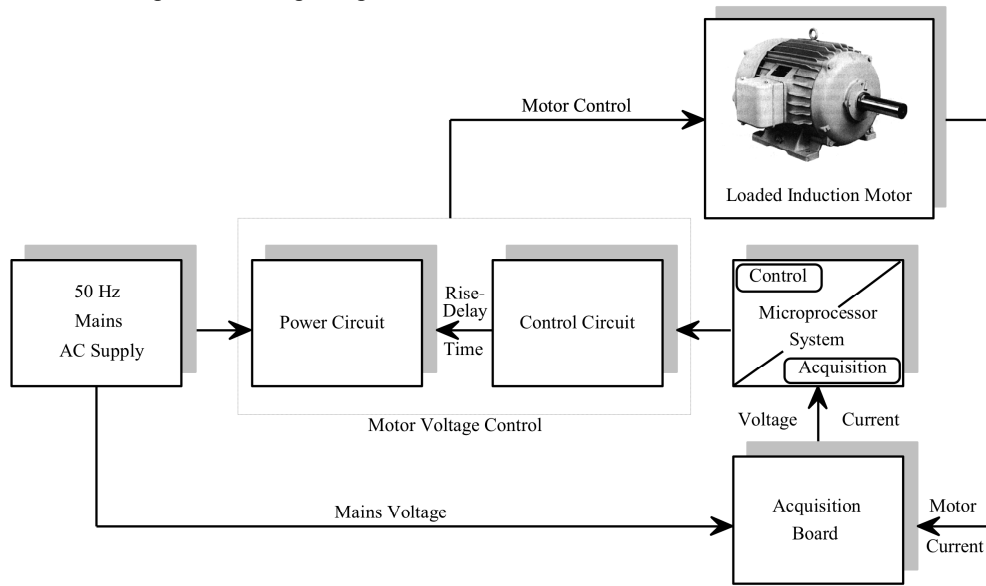

Fig. 2. Hardware block diagram.

2.1 Power circuit

Figure 3 shows a schematic diagram of a practical three-phase induction motor voltage controller. In this circuit, three triacs are placed in series with the motor supply. Voltage control is implemented by varying the conducting time of a triac. Typical voltage and current waveforms observed during operation of the controller are illustrated in Fig. 4. The angle corresponding to the instant at which a triac is triggered on with the respect to the voltage zero crossing is called the firing delay angle, α . The angle φ , or phase delay angle corresponds to the time between a voltage zero crossing and the instant at which the current fundamental component first reaches zero following that voltage zero crossing. The angle φ is somewhat erroneously also called the power factor which is only true in the case of sinusoidal steady-state. Finally, ψ is the phase delay angle introduced by the induction motor fed a triac-converter. Therefore, the voltage control is performed under the following condition, so as to minimize the harmonic pollution.

$$\alpha = \psi \tag{1}$$

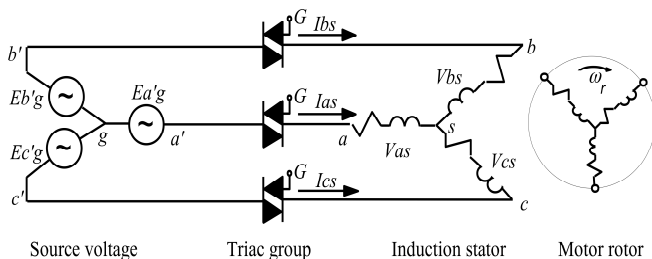

Fig. 3. Induction motor voltage controller.

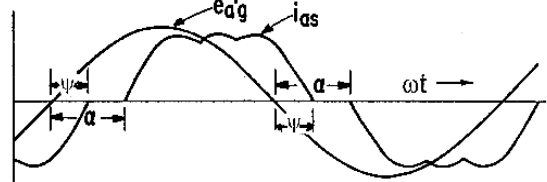

Fig. 4. Voltage controller resulting waveforms.

2.2 Acquisition and control circuits

Figures 5 and 6 show the implemented control strategy. A line voltage zero crossing detector is used to produce a signal, recognizable by the control logic, at the moment of each line voltage zero crossing. A current zero detector produces a signal, again recognizable by the control logic, indicating when the input current reaches zero. A control logic block determines the firing delay angle α required to satisfy the voltage control command (1). Contrary to Nola patent [3], an Intel 8754 microprocessor and 8 dual-in-line pin (DIP) have been used to implement the control logic block. The 8 DIP switches provide a means to input desired values for the firing delay angle.

2.3 Control algorithm

The control algorithm, as illustrated by Fig. 7, determines the phase delay angle φ by marking the instant of a voltage zero crossing and measuring the interval of time until the next current fundamental component zero crossing. Assume initially that α has been adjusted such that the current waveform is sinusoidal. As the motor load decreases, the

motor appears as a more inductive load and harmonics are introduced into the current waveform. The controller

responds by decreasing α , causing a decrease in the applied voltage fundamental component.

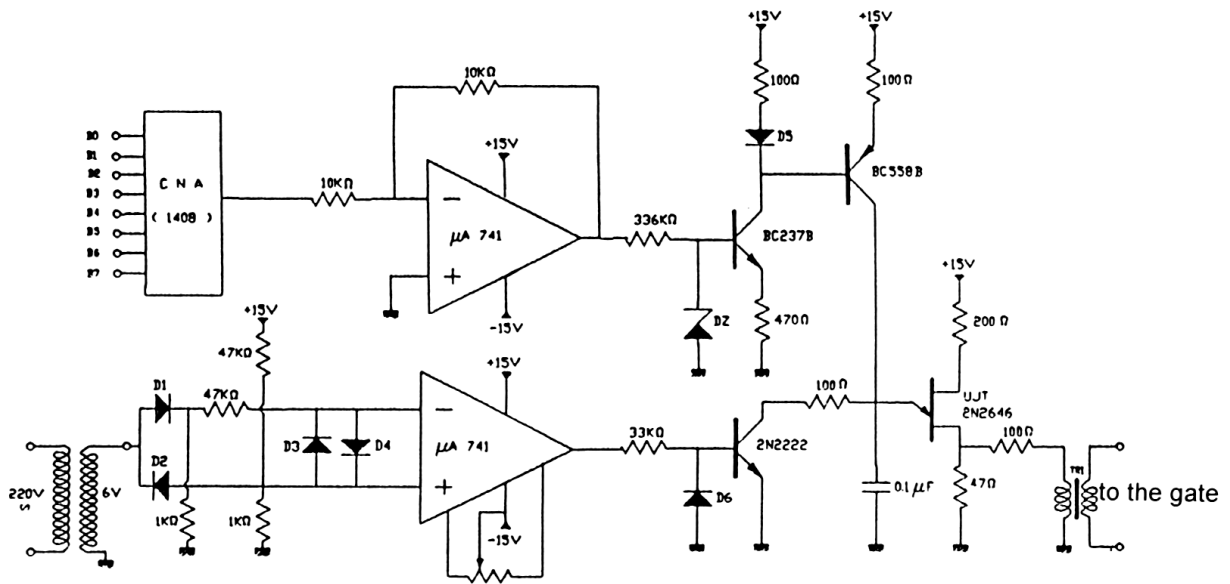

(CNA: digital-to-analog converter, UJT: uni-junction transistor)

Fig. 5. Control and firing circuit for the triac.

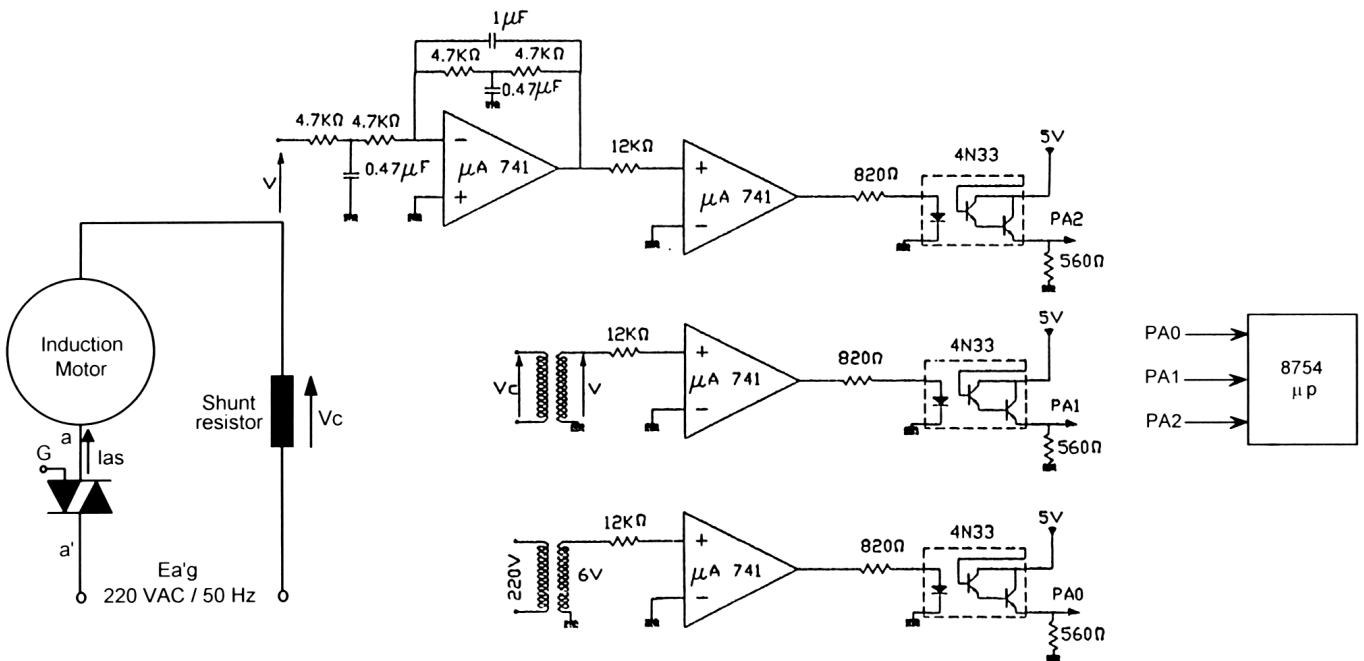

(PA0: Mains voltage, PA1: motor voltage, PA2: Motor current fundamental component)

Fig. 6. Per phase control variable acquisition circuit.

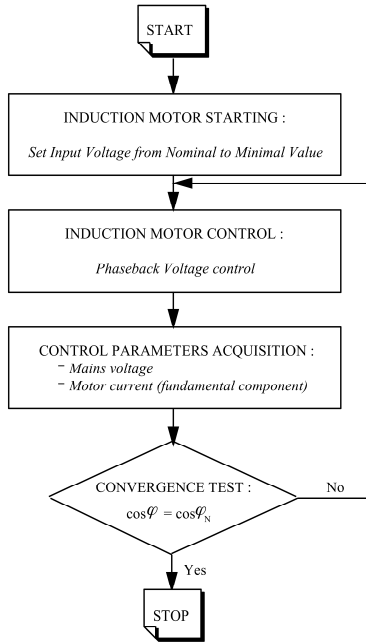

Fig. 7. Control algorithm flowchart.

The overall effect is that the motor appears as a less reactive load than when the load first decreased. The controller continues to decrease the firing delay angle α until the condition (1) is satisfied. A similar but reverse motor effect and control response occurs for increases of the load up to a load corresponding to α equal zero. A firing delay angle equal to zero means that full supply voltage has been applied to the motor. The controller now simply sends gate pulse to the triacs so as to allow full conduction.

3. Experimental tests

3.1 Experimental set-up

Experimental tests have been performed using a three-phase induction motor which ratings are summarized in the appendix. The selected motor has undergone a series of careful measurements in order to establish the proper machine parameters. It was mechanically loaded by means of a dc generator whose efficiency was evaluated at various outputs (Fig. 8).

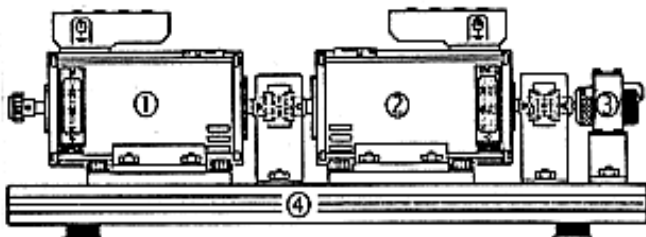

(1. DC motor, 2. DC generator, 3. Impulse transmitter, 4. Base)

Fig. 8. View of the experimental benchmark.

3.2 Experimental results

The optimized results obtained by using the voltage control algorithm are plotted in Fig. 9 and a comparison is made with the conventional system where the full voltage is applied to the motor at all loads. Voltage control, with 30% or 60% of the full voltage, substantially reduces the power consumed by the motor at low load levels. The reduction in power consumed P_C due to voltage control for various power outputs P_{OUT} is illustrated in Table I, where all powers are expressed as a percentage of the motor rated power. The power factor (PF), as an image of the motor efficiency, is considerably improved during the voltage control process (Fig. 10).

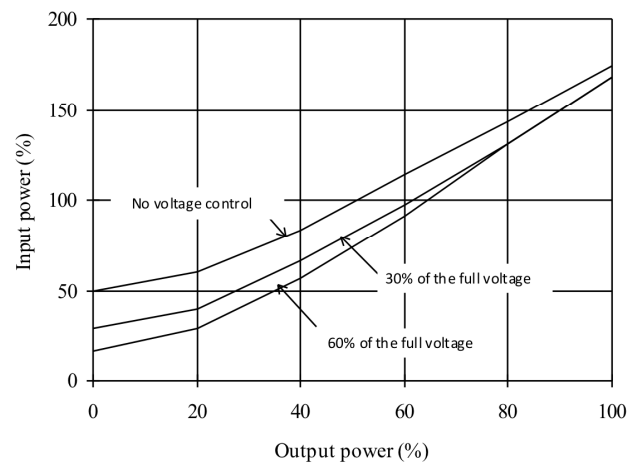

Fig. 9. Effect of voltage reduction on the power consumption.

TABLE I
REDUCTION OF THE POWER CONSUMED DUE TO VOLTAGE CONTROL

P_{out}	P_C (30%)	P_C (60%)
00.00	11.00	25.00
18.00	11.00	22.00
35.00	13.00	20.00
55.00	13.00	12.00
75.00	10.00	08.00
95.00	02.00	02.00

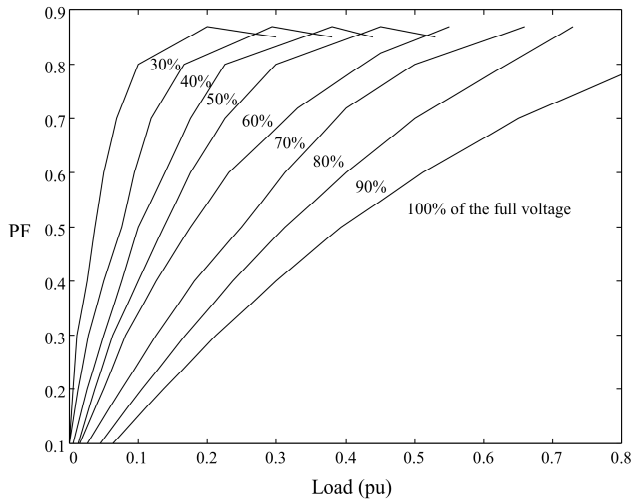

Fig. 10. Power factor versus per unit load for different input voltages.

3.3 Experimental results analysis

The energy savings with 30% or 60% of the full input voltage become essentially the same once the motor output exceeds 70% of the rated full-load value as illustrated by Table I. The reason for this lies to the fact that once the motor is substantially loaded down, the maximum efficiency is obtained at a voltage only slightly below the rated value [4]. Therefore, during reasonably loaded conditions, the wide voltage variation range provided by 60% of the full input voltage cannot be fully used. It was observed that, except at absolutely no-load, more than 50% reduction in voltage tends to stall the induction motor. This could be considered as the limit on voltage reduction. During loaded conditions, the reduction in voltage beyond a certain value causes the efficiency to decrease and the motor current to increase. The motor efficiency and current seem to reach their extrema at the same value of the motor voltage.

4. Conclusion

The key to solve the problem of optimizing (maximizing) the induction motor efficiency by a controller is to adjust the input voltage according to the required input power. The presented energy-optimal control strategy, as shown by experimental results, brings on substantial energy savings, particularly at substantial periods of light loads.

Appendix

Ratings of tested induction motor

Power	1.1	kW
Frequency	50	Hz
Voltage (Δ/Y)	220/380	V
Current (Δ/Y)	4.5/2.6	A
Speed	2820	rpm
Power factor ($\cos\phi_N$)	0.8	
Pole pair (p)	2	

References

1. N. Mohan, "Improvement in energy efficiency of induction motor by means of voltage control," *IEEE Trans. Power Apparatus and Systems*, vol. 99, n°4, July-August 1980, pp. 1466-1471.
2. R. Spée and A.K. Wallace, "Comparative evaluation of power factor improvement techniques for squirrel cage induction motors," *IEEE Trans. Industry Applications*, vol. 28, n°2, March-April 1992, pp. 381-386.
3. F. Nola, "Phase detector for three-phase power factor controller," *US Patent 4 459 528*, July 10, 1984.
4. N. Mohan, "Evaluation and comparison of state of the art techniques for energy conservation by reduced losses in ac motors," *EPRI Project RP1201-13*, 1981.

Biography



Mohamed El Hachemi Benbouzid was born in Batna, Algeria, on January 3, 1968. He received the *B.Sc.* degree in Electrical Engineering, in 1990, from the Electrical Engineering Institute of Batna University, Algeria; the *M.Sc.* degree in Electrical and Computer Engineering, in 1991, from the National Polytechnic Institute of Grenoble, France; and finally the

Ph.D. degree also in Electrical and Computer Engineering, in 1994, from the National Polytechnic Institute of Grenoble, France. After graduation, he joined the University of Picardie - Jules Verne, France, where he is Associate Professor of Electrical and Computer Engineering at the Professional Institute of Amiens. His current research interests include electric machines and drives, computational of electromagnetics, and electromechanical actuation, as well as technics for energy savings. He is actually leading a research program on the monitoring and the diagnostics of induction machine drives for the French Picardie Region. Dr. Benbouzid has published more than 40 technical papers including 10 refereed publications in journals. He is a member of the French Society of Electrical Engineers SEE. He is active in the IEEE Power Engineering Society, and is the treasurer of the French Chapter of the IEEE Power Electronics Society.