



**HAL**  
open science

# An Up-to-Date Review of Low-Voltage Ride-Through Techniques for Doubly-Fed Induction Generator-Based Wind Turbines

Mohamed Benbouzid, Sm Muyeen, Farid Khoucha

► **To cite this version:**

Mohamed Benbouzid, Sm Muyeen, Farid Khoucha. An Up-to-Date Review of Low-Voltage Ride-Through Techniques for Doubly-Fed Induction Generator-Based Wind Turbines. *International Journal on Energy Conversion*, 2015, 3 (1), pp.1-9. hal-01176088

**HAL Id: hal-01176088**

**<https://hal.science/hal-01176088v1>**

Submitted on 14 Jul 2015

**HAL** is a multi-disciplinary open access archive for the deposit and dissemination of scientific research documents, whether they are published or not. The documents may come from teaching and research institutions in France or abroad, or from public or private research centers.

L'archive ouverte pluridisciplinaire **HAL**, est destinée au dépôt et à la diffusion de documents scientifiques de niveau recherche, publiés ou non, émanant des établissements d'enseignement et de recherche français ou étrangers, des laboratoires publics ou privés.

# An Up-to-Date Review of Low-Voltage Ride-Through Techniques for Doubly-Fed Induction Generator-Based Wind Turbines

Mohamed Benbouzid<sup>1</sup>, S.M. Muyeen<sup>2</sup> and Farid Khoucha<sup>1,3</sup>

---

**Abstract** – This paper deals with low-voltage ride-through capability of wind turbines driven by a doubly-fed induction generator. This is one of the biggest challenges facing massive deployment of wind farms. With increasing penetration of wind turbines in the grid, grid connection codes in most countries require that they should remain connected to maintain reliability during and after a short-term fault. This results in low-voltage ride-through with only 15% remaining voltage at the point of common coupling, possibly even less. In addition, it is required for wind turbines to contribute to system stability during and after fault clearance. To fulfill the low-voltage ride-through requirement for doubly-fed induction generator-based wind turbines, there are two problems to be addressed, namely, rotor inrush current that may exceed the converter limit and the DC-link overvoltage. Further, it is required to limit the doubly-fed induction generator transient response oscillations during the voltage sag to increase the gear lifetime and generator reliability. There is a rich literature addressing countermeasures for LVRT capability enhancement in DFIGs; this paper is therefore intended as an up-to-date review of solutions to the low-voltage ride-through issue. Moreover, attempts are also made to highlight future issues so as to index some emerging solutions. **Copyright © 2015 Praise Worthy Prize S.r.l. - All rights reserved.**

**Keywords:** Wind turbine, doubly-fed induction generator, low voltage ride-through, grid requirements.

---

## Nomenclature

WT	=	Wind Turbine;
DFIG	=	Doubly-Fed Induction Generator;
LVRT	=	Low-Voltage Ride-Through;
PCC	=	Point of Common Coupling;
FRT	=	Fault Ride-Through;
SDR	=	Stator Damping Resistor;
ECS	=	Energy Capacitor System;
ESS	=	Energy Storage System;
RSC	=	Rotor Side Converter;
PGSR	=	Parallel Grid Side Rectifier;
SGSC	=	Series Grid Side Converter;
PMSG	=	Permanent Magnet Synchronous;
HOSM	=	High-Order Sliding Mode.

## I. Introduction

The attention soars towards the sustainable energy sources, in particular the wind energy. This one is considered as the most important and most promising renewable energy sources in terms of development. As wind-power capacity has increased, so has the need for wind power plants to become more active participants in maintaining the operability and power quality of the power grid. As a result, it becomes necessary to require wind power plants to behave as much as possible as conventional power plants [1]. An increasing number of power system operators have implemented technical

standards known as *grid codes* that wind turbines must meet when connecting to the grid [2-5]. The grid code technical specifications are divided into static and dynamic requirements. The static requirements discuss the steady state behavior and the power flow at the connection point to the transmission grid. While the dynamic requirements concern the desired wind turbine generator behavior during fault and disturbance periods. Generally, these requirements cover many topics such as, voltage operating range, power factor regulation, frequency operating range, grid support capability, and low fault ride-through capability. Indeed, grid codes dictate FRT requirements. LVRT capability is considered to be the biggest challenge in wind turbines design and manufacturing technology [6]. LVRT requires wind turbines to remain connected to the grid in presence of grid voltage sags.

The DFIG is one of the most frequently deployed large grid-connected wind turbines. Indeed, when compared with the full-scale power converter WT concept, the DFIG offers some advantages, such as reduced inverter and output filter costs due to low rotor- and grid-side power conversion ratings (25%–30%) [7-10], Power-factor control can be implemented at lower cost, because the DFIG associated to the four-quadrant converter basically operates similar to a synchronous generator. The converter has to provide only excitation energy. However, DFIG-based WTs are very sensitive to grid disturbances, especially to voltage dips [11-13].

In this particular context, this paper is intended as an up-to-date review of solutions to the low-voltage ride-through issue. Moreover, attempts are also made to highlight future issues so as to index some industrial solutions [14].

## II. Grid-Code Requirements

Grid-code requirements typically refer to large wind farms connected to the transmission system, rather than smaller stations connected to the distribution network. These new grid codes stipulate that wind farms should contribute to power system control (frequency and also voltage), much as the conventional power stations, and emphasize wind farm behavior in case of abnormal operating conditions of the network (such as in case of voltage dips). The most common requirements include FRT capability, extended system voltage and frequency variation limits, active power regulation, and frequency control, as well as reactive power/power factor and voltage regulation capabilities [15-19]. The typical grid codes main requirements are given below.

### II.1. Active Power

Wind power plants must have the ability to regulate their active power output to ensure a stable frequency in the system and to prevent overloading of transmission lines and to minimize the effect of the dynamic operation of wind turbines on the grid (during extreme wind conditions). Maximum ramp rates are imposed on the wind turbine.

### II.2. Reactive Power

Wind power plants should have a reactive power capability to maintain the reactive power balance and the power factor in the desired range (typically between 0.9 (lag) to 0.98(lead)).

### II.3. Frequency Operating Range

Wind power plants are required to run continuously within typical grid frequency variations between 49.5 Hz and 50.5 Hz.

### II.4. Low Voltage Ride-Through

In the event of a voltage drop, turbines are required to remain connected for specific time duration before being allowed to disconnect. This requirement is to ensure that there is no generation loss for normally cleared faults. Disconnecting a wind generator too quickly could have a negative impact on the grid, particularly with large wind farms.

Grid codes invariably require that large wind farms must withstand voltage sags down to a certain percentage of the nominal voltage and for a specified duration. Such constraints are known as FRT or LVRT requirements. They are described by a voltage versus time characteristic, denoting the minimum required immunity of the wind power station to the system voltage sags (Figs.1 and 2) [20].

## III. Problem Statement

As previously mentioned, DFIGs suffer from grid-disturbance sensitivity. The reason behind this problem is related to the fact that the DFIG stator is directly connected to the grid, as shown in Fig. 3 [21].

During grid faults, one or more of the phase voltages at the PCC may suddenly drop to close to zero. This results in large stator current transients, leading to high currents flowing through the converters due to the magnetic coupling between stator and rotor windings [20]. As the converter ratings are defined according to the desired variable speed range under normal grid voltage conditions, it may not be possible to synthesize the control action required to control the rotor currents during transients. Indeed, when the rotor-side voltage or current reaches the power converter limit, DFIG control is lost and protected against the converter thermal breakdown. Even if the DFIG is subjected to small stator voltage imbalance, with the converter operating inside its limits, the stator current may be highly unbalanced, leading to torque pulsations that result in acoustic noise and, at high levels, may destroy the rotor shaft, gearbox, and blade assembly [23-24].

Dedicated countermeasures, in terms of protection and control, are therefore needed.

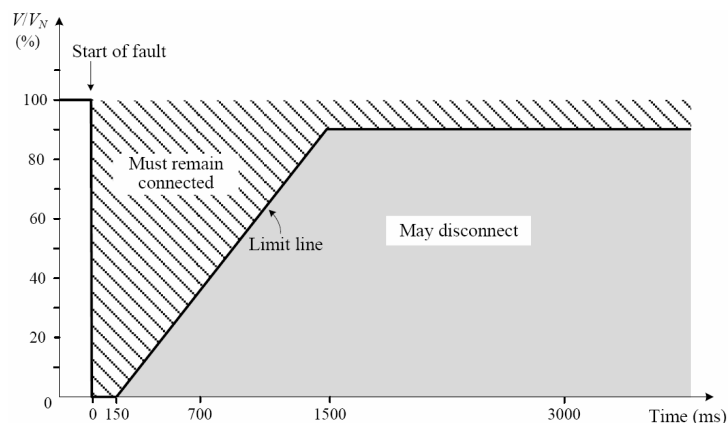

Fig. 1. Typical LVRT curve.

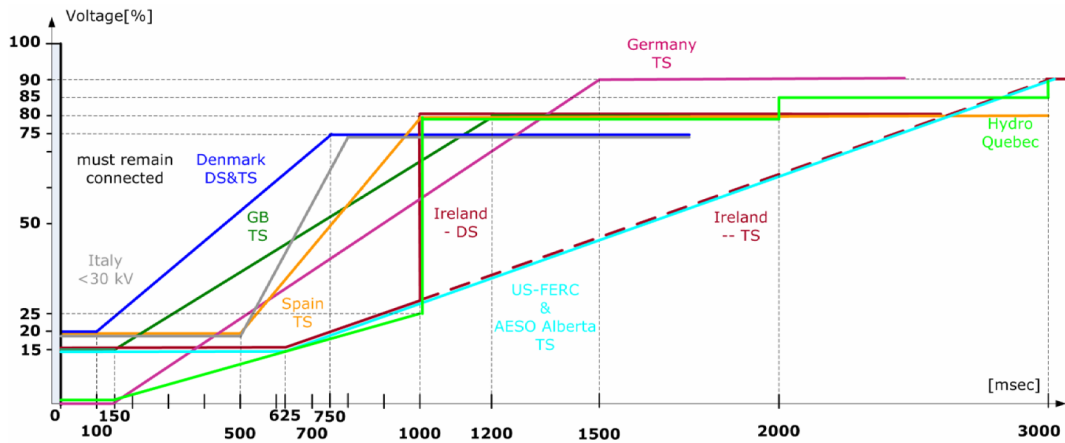

Fig. 2. LVRT requirements for different countries [20].

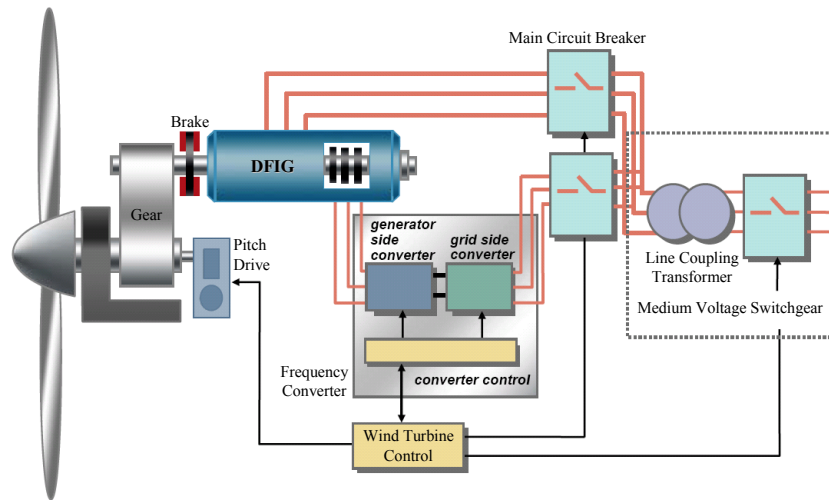

Fig. 3. Schematic diagram of a DFIG-based wind turbine.

#### IV. DFIG-Based WT LVRT Technologies Review

Several countermeasures discussed in the literatures have addressed the LVRT capability enhancement in DFIGs.

These approaches can be divided into two main categories: 1) *Passive Methods* using additional equipments such as blade pitch angle control, crowbar methods; ECS or DC capacitor sizing, and ESS or DC bus energy storage circuit (Fig. 4); and 2) *Active Methods* using appropriate converter control.

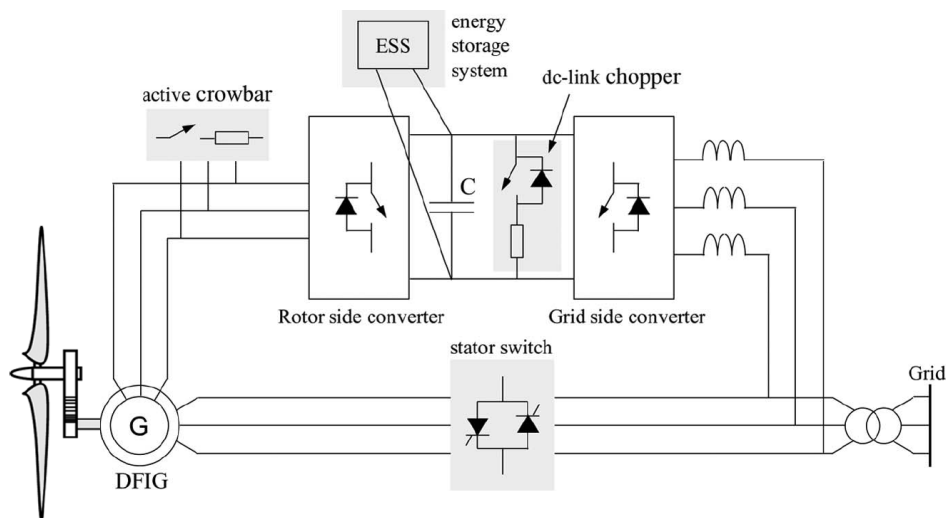

Fig. 4. Rotor and converter protection devices.

#### IV.1. Passive Methods

1) *Blade pitch angle control.* Pitch control achieves power reduction by rotating each blade to reduce their attack angle. In comparison with passive stall, pitch control provides an increased energy capture at rated wind speed and above. Constant-speed wind turbines can be equipped with pitch drives which quickly increase the pitch angle when rotor acceleration is detected. This reduces the mechanical power and consequently limits the rotor speed and the reactive power consumption after the fault [25-26]. Figure 5 illustrates the basic principle of a pitch angle controller, where  $\theta$  is the pitch angle.

2) *Crowbar methods.* The classical solution to fulfill LVRT requirements is the use of the rotor crowbar method as shown in Fig. 6 [11-12], [23]. It is the mainstream scheme adopted by manufacturers to ride-through grid faults. Although the crowbar is a cost-effective method able to protect the generator and the converter during the faults, it has some disadvantages that cannot be overlooked. Its major disadvantage is that, the DFIG loses its controllability once the crowbar is triggered, due to the rotor-side converter deactivating. In such a situation, the DFIG absorbs a large amount of reactive power from the grid, leading to further grid voltage degradation. In addition, the crowbar resistance should also be carefully calculated, chosen as 20 times the rotor resistance, in order to provide sufficient damping and minimum energy consumption.

Considering these drawbacks, another crowbar arrangement was proposed [27], where the crowbar is in series with the stator windings as shown in Fig. 7. Nevertheless, there are conduction losses of the bidirectional switches during normal operation. Therefore, special consideration should be taken when designing the power electronics, for minimizing these losses.

In the same passive context, it has also been proposed to use Stator Damping Resistor located in series with the stator windings. SDR consists of three resistors in parallel with three bypassing bidirectional static switches as illustrated by Fig. 8 [28]. In normal conditions, the bidirectional static switches remain closed and the stator current will not flow through the SDR. The proposed LVRT approaches seem to be more efficient than those using conventional crowbars mainly due to lower oscillations of DFIG transient response. In addition, using these approaches, it seems possible to enhance DFIG ride-through capability as the main drawback of the crowbar is losing the DFIG control during faulty operation [29].

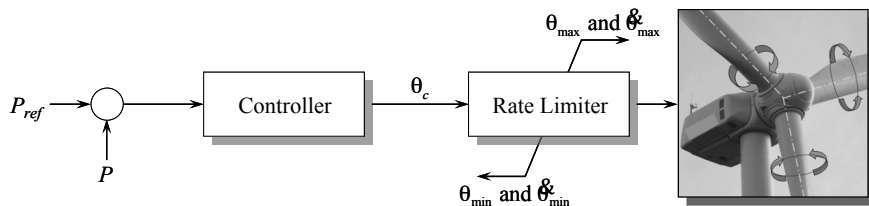

Fig. 5. Pitch angle control strategy.

3) *Energy capacitor system.* The DC capacitor sizing method is similar to some extent to a crowbar configuration, except that this method protects the IGBTs from overvoltage and can dissipate energy. However, this has no effect on the rotor currents [30-31].

An ECS consists of a voltage converter, a DC link, a DC-DC buck/boost regulator connected to an Electrical Double Layer Capacitor (EDLC) as shown by Fig. 9.

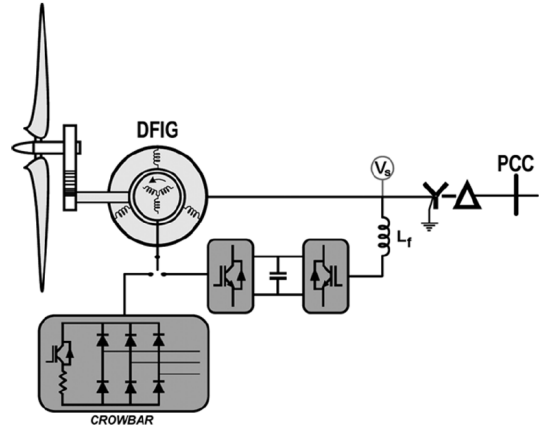

Fig. 6. Classical rotor-side crowbar [23].

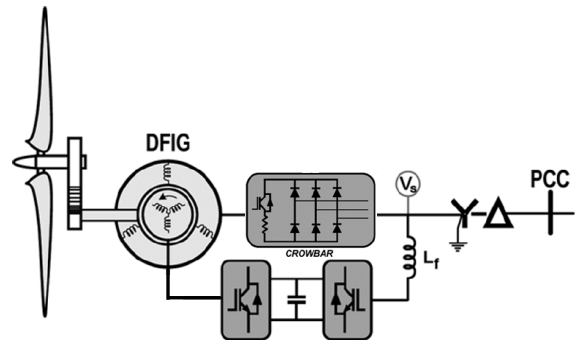

Fig. 7. Stator-side crowbar.

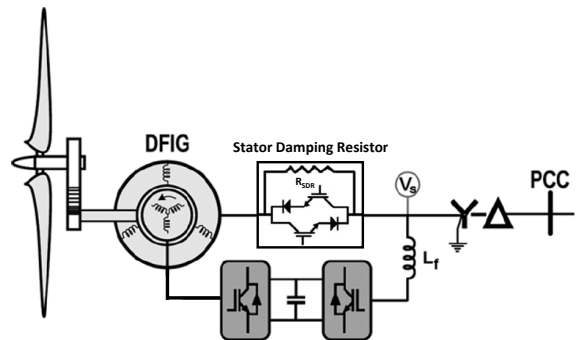

Fig. 8. DFIG-based wind turbine with SDR [28].

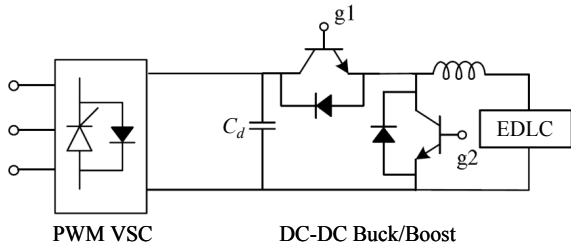

Fig. 9. ECS configuration.

4) *Energy storage system.* ESS-based methods have the ability to control the generator during the fault. However, the rotor-side converter must be sized accordingly in order to allow fault currents to flow through the DFIG rotor circuit as illustrated by Fig. 10. Moreover, additional energy storage devices are required leading to the system increased cost and complexity [32-34].

The ESS incorporated in the system combines the FRT improvement with grid injected power smoothing. However, riding through faults might affect the ability to smooth power fluctuations and vice-versa, as both operations use the same energy storage device. In this context, a specific control design is required [35].

Although an ESS can help stabilize the DC link voltage and smooth the output power simultaneously, it is very difficult to eliminate the overcurrent and electromagnetic torque oscillations. To solve this proposed in [36] a superconducting fault-current limiter magnetic energy storage system. The proposed system is composed of three isolation transformers, a diode rectifier, and a superconducting coil (Fig. 11). In this context, the superconducting coil will be used as the energy storage device and the fault-current limiting inductor simultaneously. It can therefore help the DFIG to smooth output power fluctuations and enhance LVRT capability.

#### IV.2. Actives Methods

In this context, it has also been proposed combination between hardware modifications (e.g., crowbar) and control strategies [37-38]. The authors propose a feed-forward transient current control scheme for the RSC of a DFIG with crowbar protection.

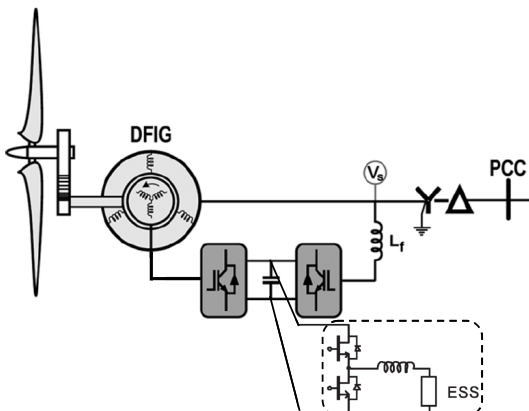

Fig. 10. DFIG-based WT equipped with ESS.

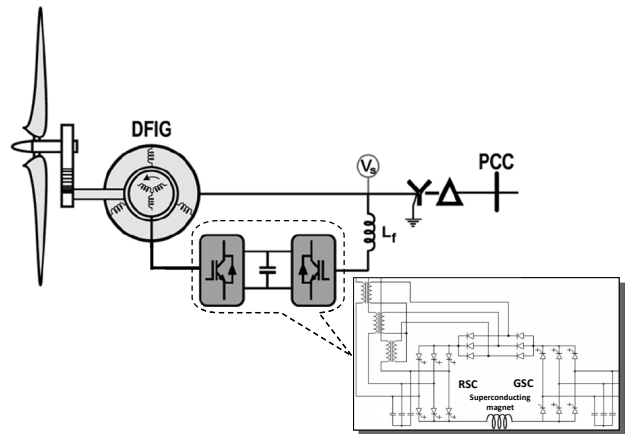

Fig. 11. DFIG-based WT equipped with a superconducting fault-current limiter.

By injecting additional feed-forward transient compensation terms into the outputs of a conventional (PI) RSC current controller, the RSC AC-side output voltage will be aligned with the transient-induced voltage resulting in minimum transient rotor current and minimum occurrence of crowbar interruptions. Compared to the conventional controller, little additional computation effort is needed in this new control scheme.

Another solution is proposed by [39]. The proposed configuration uses a parallel grid side rectifier (PGSR) with a series grid side converter (SGSC) as shown in Fig. 12. The combination of these two converters enables unencumbered power processing and robust voltage disturbance ride through. It was reported that the generator side converter recovers the rotor slip into the DC link as in a traditional DFIG. However, a series-connected grid side converter is used to inject the DC link power into the grid. Although this approach allows power flow control over a typical operating range above and below synchronous speed, the DFIG suffers at subsynchronous speeds. Therefore, a parallel-connected passive rectifier rated at a small fraction of the total power is used to restore the overall system maximal utilization.

Yet, all these solutions require additional devices. This leads to extra costs and increase the system complexity. In contrast, the Brushless DFIG (BDFIG) typically has a larger series leakage reactance and thereby experiences a reduced transient current when compared to an equivalent DFIG [11] from the machine-side converter view.

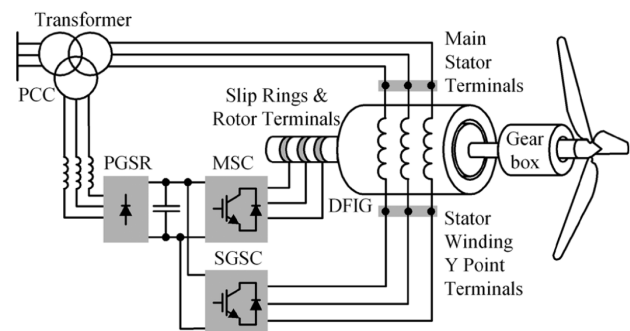

Fig. 12. DFIG-based WT with PGSR and SGSC [39].

Therefore, it may be possible for the BDFIG to ride through a low-voltage fault without the need of a crowbar circuit or additional zero-sequence current compensation or creating any virtual impedance by using extra control feedback loop. Hence, the system cost will be reduced, and the machine-side converter can also be utilized to supply reactive current during the fault to satisfy grid regulations [40].

For a classical DFIG, it would be better to eliminate additional devices. With these considerations, the implementation of classical flux-oriented vector control techniques (PI controllers) has been proven to work well for the accomplishment of the initial grid code requirements [41-42]. But, this kind of control could be easily saturated when dealing with substantial sag. Moreover, it is sensitive to the generator parameters and other phenomena such as disturbances and unmodeled dynamics [43-46].

### IV.3. Advanced Actives Methods

Recent network operator requirements seem to lead to more robust control techniques [15]. Indeed, the above classical control techniques main drawback is their linear nature that lacks robustness when facing a worst-case operation scenario. Nonlinear controllers usually have a more complicated structure and seem harder to implement in practice. From an industrial point of view, it is preferable to use simple linear robust controllers in wind turbines; however, for robust performance, the nonlinearities need to be taken into account when the controllers are designed. In this context, it should be mentioned that there are few publications addressing the nonlinear control of DFIGs during grid faults [25], [47-51].

For instance, the work presented in [25] proposes a robust nonlinear controller based on the sliding mode. This controller is designed in a stationary reference frame. The behavior of this controller is investigated and tested under unbalanced voltage dip conditions. Some experimental results are given to confirm the proposed controller efficiency. The main limitation of this solution is the chattering problem.

In [48], the authors try to extend the concept of DFIG LVRT without the use of additional hardware in the case of a fault resulting in a bigger voltage dip, as it is required from grid codes. In this case, the controllers were designed based on fuzzy logic and genetic algorithms to handle the system modeling uncertainties and its nonlinearity. This LVRT approach still needs experimental validation. In this [49], it is proposed a method which is used to design a linear controller that is sufficiently robust to accommodate post-fault low-voltage conditions. The designed robust decentralized output-feedback control seems guaranteeing stability if the system post-fault operating point is in the region for which the controller is designed. The GSC control has been designed to stabilize both internal and external dynamics and limit DC link voltage fluctuations. In [50], an LVRT scheme for a PMSG-based WT is proposed. Based on the feedback linearization theory, the DC link

voltage is controlled by the generator rotor-side converter instead of the grid-side converter which is usually used. In [51], it is suggested a susceptance control strategy which can cater for the reactive power requirement. The susceptance is adjusted through a robust feedback controller included in the terminal voltage driven automatic excitation control circuit. The fixed parameter robust controller design was carried out in frequency domain using multiplicative uncertainty modeling and  $H_\infty$  norms. The robust controller has demonstrated capability to ride through low voltage conditions. However, this LVRT approach still needs experimental validation.

Recently, in [52-54], another control strategy using a high-order sliding mode (HOSM) technique has been proposed (Fig. 13). Such a control scheme, contrary to the traditional PI controller, presents attractive features such as chattering-free behavior (no extra mechanical stress), finite reaching time, and robustness with respect to external disturbances (grid) and unmodeled dynamics (DFIG and WT). The achieved results show promising successful ride-through performances over well-known PI-based control and even over classical sliding mode control (first-order). In addition, it should be particularly mentioned that the proposed HOSM control approach does not need any specific adjustments to fault ride-through purposes [54].

## V. Technology Solutions to the LVRT Issue

Newer turbine models from industry leaders come with LVRT as integral. Full converter wind turbines have the greatest ability to meet the most restrictive grid codes (although many products currently on the market do not) [55]. These also offer the highest levels of flexibility in generator technology, and are gaining ground in the marketplace. For example, ENERCON has a full converter turbine, as does VESTAS in its *V112 3MW* model.

However, turbines based upon the DFIG concept, which use relatively small converters, are also in almost all cases unable to meet rising LVRT and reactive power requirements. This is the dominant technology in terms of existing capacity [56].

Technology suppliers have therefore been working with transmission grid operators and turbine manufacturers to introduce technological solutions to the LVRT issue. Companies such as ELSPEC [57] have introduced systems to inject reactive power, while AMSC [58] and ZIGOR [59] have developed uninterruptible supply solutions.

In particular W2PS has developed a voltage sag compensator, named Coverdip<sup>®</sup>, to provide wind turbines with LVRT capability. The developed compensator uses a series connected converter to inject the exact voltage that is required to fill in the voltage sag at the terminals of the wind turbine. It has been tested under the Spanish grid code requirements [56], [60].

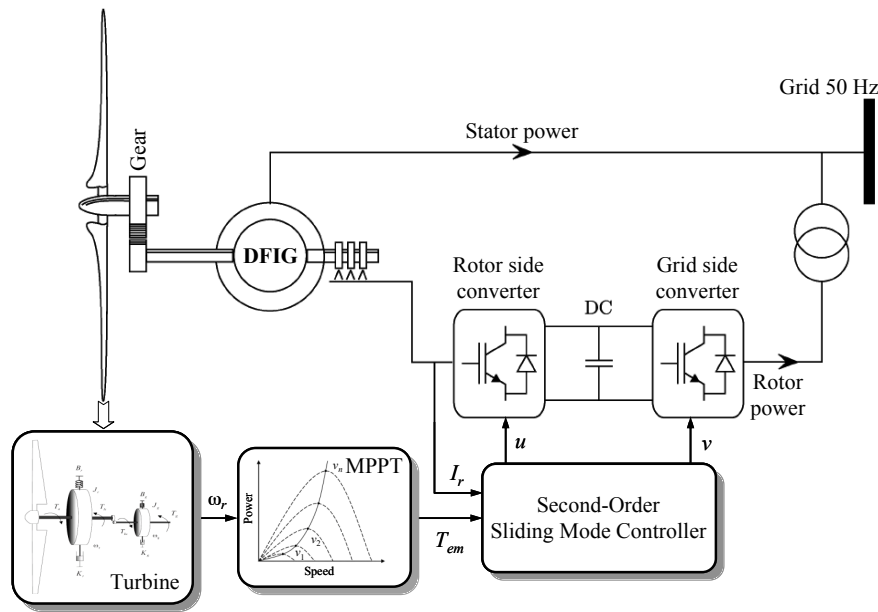

Fig. 13. DFIG-based WT LVRT using HOSM [54].

## VI. Summary

LVRT is found to be one of the biggest challenge facing wind turbine farms massive deployment; in particular those using DFIGs. This type of generator is unfortunately sensitive to grid disturbance, in particular voltage sags. To overcome this sensitivity, several hardware and control strategies have been proposed. These strategies have been examined and advantages and disadvantages of each one have been discussed. The use of additional hardware can be avoided if the rotor-side converter is able to counter the grid disturbance effects. Therefore, particular attention has been drawn to nonlinear control strategies. At this time, just few papers deals with this cost-effective solution to the LVRT issue. In this context, Future investigations should therefore be focused on the development of DFIG robust nonlinear control strategies.

## References

- [1] R. Passey, T. Spooner, I. MacGill, M. Watt and K. Syngellakis, "The potential impacts of grid-connected distributed generation and how to address them: A review of technical and non-technical factors," *Energy Policy*, vol. 39, n°10, pp. 6280-6290, October 2011.
- [2] FERC, "Interconnection for wind energy," Docket N°RM05-4-000 – Order N°661, USA, June 2005.
- [3] FERC, "Interconnection for wind energy," Docket N°RM05-4-001; Order N°661-A, USA, December 2005.
- [4] E.On Netz GmbH, Bayreuth, Grid Code, High- and Extra-High Voltage, April 2006, available at <http://www.eon-netz.com/>.
- [5] Ireland National Grid, Grid Code Version 2, "Wind farm power station grid code provisions, WFPS1," pp.213-216, January 2007.
- [6] X. Yingcheng and T. Nengling, "Review of contribution to frequency control through variable speed wind turbine," *Renewable Energy*, vol. 36, n°6, pp 1671-1677, June 2011.
- [7] M. Liserre, R. Cardenas, M. Molinas and J. Rodriguez, "Overview of multi-MW wind turbines and wind parks," *IEEE Trans. Industrial Electronics*, vol. 58, n°4, pp. 1081-1095, April 2011.
- [8] Mohsen Rahimi, "Dynamic performance assessment of DFIG-based wind turbines: A review," *Renewable and Sustainable Energy Reviews*, vol. 37, pp. 852-866, September 2014.
- [9] C. Sasi and G. Mohan, "Power quality improvement of grid connected wind energy conversion system during transient fault," *International Journal on Energy Conversion*, vol. 1, n°1, pp. 28-34, January 2013.
- [10] Y. Amirat, M.E.H. Benbouzid, B. Bensaker and R. Wamkeue, "Generators for wind energy conversion systems: State of the art and coming attractions," *Journal of Electrical Systems*, vol. 3, n°1, pp. 26-38, March 2007.
- [11] S. Tohidi, P. Tavner, R. McMahon, H. Oraee, M.R. Zolghadri, S. Shao and E. Abdi, "Low voltage ride-through of DFIG and brushless DFIG: Similarities and differences," *Electric Power Systems Research*, vol. 110, pp. 64-72, May 2014.
- [12] H.T. Jadhav and R. Roy, "A comprehensive review on the grid integration of doubly fed induction generator," *International Journal of Electrical Power & Energy Systems*, vol. 49, pp. 8-18, July 2013.
- [13] E. Gómez-Lázaro, J.A. Fuentes, A. Molina-García and M. Cañas-Carretón, "Characterization and visualization of voltage dips in wind power installations," *IEEE Trans. Power Delivery*, vol. 24, n°4, pp. 2071-2078, October 2009.
- [14] M. Ezzat, M.E.H. Benbouzid, S.M. Mueeen and L. Harnefors, "Low-voltage ride-through techniques for DFIG-based wind turbines: State-of-the-art review and future trends," in *Proceedings of the 2013 IEEE IECON*, Vienna (Austria), pp. 7681-7686, November 2013.
- [15] M. Tsili and S. Papathanassiou, "A review of grid code technical requirements for wind farms," *IET Renewable Power Generation*, vol. 3, n°3, pp. 308-332, September 2009.
- [16] B. Singh and S.N. Singh, "Wind power interconnection into the power system: A review of grid code requirements," *The Electricity Journal*, vol. 22, n°5, pp. 54-63, 2009.
- [17] B. Singh, S.N. Singh and L. Wang, *Electric grid connection and system operational aspect of wind power generation*, in *Wind Energy Conversion System: Technology and Trends*, S.M. Mueeen, (Eds.), Springer-Verlag: UK 2012.
- [18] M. Mohseni and S.M. Islam, "Review of international grid codes for wind power integration: Diversity, technology and a case for global standard," *Renewable and Sustainable Energy Reviews*, vol.16, n°6, pp. 3876-3890, August 2012.
- [19] M. Mohseni and S.M. Islam, "Transient control of DFIG-Based wind power plants in compliance with the Australian grid code," *IEEE Trans. Power Electronics*, vol. 27, n°2, pp. 2813-2824, June 2012.



- [20] F. Iov, A. D. Hansen, P. Sørensen and N. A. Cutululis, "Mapping of grid faults and grid codes," *Tech. Rep. Risø-R-1617(EN)*, Risø Nat. Lab., Tech. Univ. Denmark, Roskilde, Denmark, Jul. 2007.
- [21] G.D. Marques and D.M. Sousa, "Understanding the doubly fed induction generator during voltage dips," *IEEE Trans. Energy Conversion*, vol. 27, n°2, pp. 421-431, June 2012.
- [22] Y. Ling and X. Cai, "Rotor current dynamics of doubly fed induction generators during grid voltage dip and rise," *International Journal of Electrical Power & Energy Systems*, vol. 44, n°1, pp. 17-24, January 2013.
- [23] F.K.A. Lima, A. Luna, P. Rodriguez, E.H. Watanabe and F. Blaabjerg, "Rotor voltage dynamics in the doubly fed induction generator during grid faults," *IEEE Trans. Power Electronics*, vol. 25, n°1, pp. 118-13, January 2010.
- [24] P. da Costa, H. Pinheiro, T. Degner and G. Arnold, "Robust controller for DFIGs of grid-connected wind turbines," *IEEE Trans. Industrial Electronics*, vol. 58, n°9, pp. 4023-4038, September 2011.
- [25] M.J. Hossain, H.R. Pota, V.A. Ugrinovskii and R.A. Ramos, "Simultaneous STATCOM and pitch angle control for improved LVRT capability of fixed-speed wind turbines," *IEEE Trans. Sustainable Energy*, vol. 1, n°3, pp. 142-151, October 2010.
- [26] M.J. Hossain, H.R. Pota and R.A. Ramos, "Robust STATCOM control for the stabilisation of fixed-speed wind turbines during low voltages," *Renewable Energy*, vol. 36, n°11, pp. 2897-2905, November 2011.
- [27] K.E. Okeku, S.M. Mueeen, R. Takahashi and J. Tamura, "Wind farms fault ride through using DFIG with new protection scheme," *IEEE Trans. Sustainable Energy*, vol. 3, n°3, pp. 242-254, April 2012.
- [28] M. Rahimi and M. Parniani, "Efficient control scheme of wind turbines with doubly fed induction generators for low-voltage ride-through capability enhancement," *IET Renewable Power Generation*, vol. 4, n°3, pp. 242-252, 2010.
- [29] M. Rahimi and M. Parniani, "Low voltage ride-through capability improvement of DFIG-based wind turbines under unbalanced voltage dips," *International Journal of Electrical Power & Energy Systems*, vol. 60, pp. 82-95, September 2014.
- [30] S.M. Mueeen, R. Takahashi, T. Murata, J. Tamura, M.H. Ali, Y. Matsumura, A. Kuwayama and T. Matsumoto, "Low voltage ride through capability enhancement of wind turbine generator system during network disturbance," *IET Renewable Power Generation*, vol. 3, n°1, pp. 65-74, 2009.
- [31] S.M. Mueeen, R. Takahashi, M.H. Ali, T. Murata and J. Tamura, "Transient stability augmentation of power system including wind farms by using ECS," *IEEE Trans. Power Systems*, vol. 23, n°3, pp. 1179-1187, August 2008.
- [32] F. Díaz-González, A. Sumper, O. Gomis-Bellmunt and R. Villafañila-Robles, "A review of energy storage technologies for wind power applications," *Renewable and Sustainable Energy Reviews*, vol. 16, n°4, pp. 2154-2171, May 2012.
- [33] A.H.M.A. Rahim and E.P. Nowicki, "Supercapacitor energy storage system for fault ride-through of a DFIG wind generation system," *Energy Conversion and Management*, vol. 59, pp. 96-102, July 2012.
- [34] M.J. Hossain, H.R. Pota, V.A. Ugrinovskii and R.A. Ramos, "Improved low-voltage-ride-through capability of fixed speed wind turbines using decentralised control of STATCOM with energy storage system," *IET Generation, Transmission & Distribution*, vol. 6, n°8, pp. 719-730, 2012.
- [35] S.I. Gkavanoudis and C.S. Demoulias, "A combined fault ride-through and power smoothing control method for full-converter wind turbines employing supercapacitor energy storage system," *Electric Power Systems Research*, vol. 106, pp. 62-72, January 2014.
- [36] W. Guo, L. Xiao and S. Dai, "Enhancing low-voltage ride-through capability and smoothing output power of DFIG with a superconducting fault-current limiter-magnetic energy storage system," *IEEE Trans. Energy Conversion*, vol. 27, n°2, pp. 277-295, June 2012.
- [37] J. Liang, W. Qiao and R.G. Harley, "Feed-forward transient current control for low-voltage ride-through enhancement of DFIG wind turbines," *IEEE Trans. Energy Conversion*, vol. 25, n°3, pp. 836-843, September 2010.
- [38] D. Ramirez, S. Martinez, F. Blazquez and C. Carrero, "Use of STATCOM in wind farms with fixed-speed generators for grid code compliance," *Renewable Energy*, vol. 37, n°1, pp. 202-212, January 2012.
- [39] P.S. Flannery and G. Venkataramanan, "A fault tolerant doubly fed induction generator wind turbine using a parallel grid side rectifier and series grid side converter," *IEEE Trans. Power Electronics*, vol. 23, n°3, pp. 1126-1135, May 2008.
- [40] L. Teng, S. Shiyi, P. Malliband, E. Abdi and R.A. McMahon, "Crowbarless fault ride-through of the brushless doubly fed induction generator in a wind turbine under symmetrical voltage dips," *IEEE Trans. Industrial Electronics*, vol. 60, n°7, pp. 2833-2841, July 2013.
- [41] L. Yang, Z. Xu, J. Ostergaard, Z.Y. Dong and K.P. Wong, "Advanced control strategy of DFIG wind turbines for power system fault ride through," *IEEE Trans. Power Systems*, vol. 27, n°2, pp. 713-722, May 2012.
- [42] A.E. Leon, J.M. Mauricio and J.A. Solsona, "Fault ride-through enhancement of DFIG-based wind generation considering unbalanced and distorted conditions," *IEEE Trans. Energy Conversion*, vol. 27, n°3, pp. 775-783, September 2012.
- [43] R. Cardenas, R. Pena, S. Alepuz and G. Asher, "Overview of control systems for the operation of DFIGs in wind energy applications," *IEEE Trans. Industrial Electronics*, vol. 60, n°7, pp. 2776-2798, July 2013.
- [44] T. Long, S. Shao, C.Y. Li, Chun-Yin, E. Abdi and R.A. McMahon, "Crowbarless fault ride-through of the brushless doubly fed induction generator in a wind turbine under symmetrical voltage dips," *IEEE Trans. Industrial Electronics*, vol. 60, n°7, pp. 2833-2841, July 2013.
- [45] H. Geng, C. Liu and G. Yang, "LVRT capability of DFIG-based WECS under asymmetrical grid fault condition," *IEEE Trans. Industrial Electronics*, vol. 60, n°6, pp. 2495-2509, June 2013.
- [46] S. Xiao, G. Yang, H. Zhou and H. Geng, "An LVRT control strategy based on flux linkage tracking for DFIG-based WECS," *IEEE Trans. Industrial Electronics*, vol. 60, n°7, pp. 2820-2832, July 2013.
- [47] M.J. Hossain, H.R. Pota and R.A. Ramos, "Robust STATCOM control for the stabilisation of fixed-speed wind turbines during low voltages," *Renewable Energy*, vol. 36, n°11, pp. 2897-2905, November 2011.
- [48] T.D. Vrionis, X.I. Koutiva and N.A. Vovos, "A genetic algorithm-based low voltage ride-through control strategy for grid connected doubly fed induction wind generators," *IEEE Trans. Power Systems*, vol. 29, n°3, pp. 1325-1334, May 2014.
- [49] M.J. Hossain, T.K. Saha, N. Mithulananthan and H.R. Pota, "Control strategies for augmenting LVRT capability of DFIGs in interconnected power systems," *IEEE Trans. Industrial Electronics*, vol. 60, n°6, pp. 2510-2522, June 2013.
- [50] K.H. Kim, Y.C. Jeung, D.C. Lee and H.G. Kim, "LVRT scheme of PMSG wind power systems based on feedback linearization," *IEEE Trans. Power Electronics*, vol. 27, n°5, pp. 2376-2384, May 2012.
- [51] A.H.M.A. Rahim and E.P. Nowicki, "Performance of a grid-connected wind generation system with a robust susceptance controller," *Electric Power Systems Research*, vol.81, n°1, pp. 149-157, January 2011.
- [52] M.E.H. Benbouzid, B. Beltran, Y. Amirat, G. Yao, J. Han and H. Mangel, "Second-order sliding mode control for DFIG-based wind turbines fault ride-through capability enhancement," *ISA Transactions*, vol. 53, n°3, pp. 827-833, May 2014.
- [53] M.E.H. Benbouzid, B. Beltran, M. Ezzat and S. Breton, "DFIG driven wind turbine grid fault-tolerance using high-order sliding mode control," *International Review on Modelling and Simulations*, vol. 6, n°1, pp. 29-32, February 2013.
- [54] B. Beltran, M.E.H. Benbouzid and T. Ahmed-Ali, "Second-order sliding mode control of a doubly fed induction generator driven wind turbine," *IEEE Trans. Energy Conversion*, vol. 27, n°2, pp. 261-269, June 2012.
- [55] D. Ramirez, S. Martinez, C. Carrero and C.A. Platero, "Improvements in the grid connection of renewable generators with full power converters," *Renewable Energy*, vol. 43, pp. 90-100, July 2012.

- [56] P. Crossley and A. Beviz, "Smart energy systems: Transitioning renewables onto the grid," *Renewable Energy Focus*, vol. 11, n°5, pp. 58-59, September–October 2010.
- [57] <http://www.elspec-ltd.com/>
- [58] <http://www.amsc.com/>
- [59] <http://www.zigor.com/>
- [60] J.M. Corcelles, J.L. Rodríguez-Amenedo, D. Santos and S. Arnaltes, "Voltage sag compensation for providing wind turbine low voltage ride-through capability," in *Proceedings of the 2009 EVEC*, Marseille (France), pp.1-3, March 2009.

<sup>1</sup>University of Brest, EA 4325 LBMS, Rue de Kergoat, CS 93837, 29238 Brest Cedex 03, France (e-mail: Mohamed.Benbouzid@univ-brest.fr).

<sup>2</sup>Electrical Engineering Department, Petroleum Institute, Abu Dhabi 2533, United Arab Emirates (e-mail: smmuyeen@pi.ac.ae).

<sup>3</sup>Ecole Militaire Polytechnique, Laboratoire d'Electronique de Puissance, 16111 Algiers, Algeria (e-mail: fkhoucha04@yahoo.fr).



**Mohamed El Hachemi Benbouzid** was born in Batna, Algeria, in 1968. He received the B.Sc. degree in electrical engineering from the University of Batna, Batna, Algeria, in 1990, the M.Sc. and Ph.D. degrees in electrical and computer engineering from the National Polytechnic Institute of Grenoble, Grenoble, France, in 1991 and 1994, respectively, and the Habilitation à Diriger des Recherches degree from the University of Picardie "Jules Verne," Amiens, France, in 2000.

After receiving the Ph.D. degree, he joined the Professional Institute of Amiens, University of Picardie "Jules Verne," where he was an Associate Professor of electrical and computer engineering. Since September 2004, he has been with the Institut Universitaire de Technologie de Brest, University of Brest, Brest, France, where he is a Professor of electrical engineering. His main research interests and experience include analysis, design, and control of electric machines, variable-speed drives for traction, propulsion, and renewable energy applications, and fault diagnosis of electric machines.

Prof. Benbouzid is an IEEE Senior Member. He is the Editor-in-Chief of the INTERNATIONAL JOURNAL ON ENERGY CONVERSION (IRECON). He is also an Associate Editor of the IEEE TRANSACTIONS ON ENERGY CONVERSION, the IEEE TRANSACTIONS ON INDUSTRIAL ELECTRONICS, the IEEE TRANSACTIONS ON SUSTAINABLE ENERGY, and the IEEE TRANSACTIONS ON VEHICULAR TECHNOLOGY. He was an Associate Editor of the IEEE/ASME TRANSACTIONS ON MECHATRONICS from 2006 to 2009.



**Dr. S. M. Mueen** (S'03–M'08–SM'12) received his B.Sc. Eng. Degree from Rajshahi University of Engineering and Technology (RUET), Bangladesh formerly known as Rajshahi Institute of Technology, in 2000 and M. Sc. Eng. and Dr. Eng. Degrees from Kitami Institute of Technology, Japan, in 2005 and 2008, respectively, all in Electrical and Electronic Engineering. His PhD research work focused on wind farm stabilization from the viewpoint of LVRT and frequency fluctuation.

After completing his Ph.D. program he worked as a Postdoctoral Research Fellow under the versatile banner of Japan Society for the Promotion of Science (JSPS) from 2008-2010 at the Kitami Institute of Technology, Japan. At the present, he is working as Associate Professor in Electrical Engineering Department at the Petroleum Institute, Abu Dhabi. His research interests are power system stability and control, electrical machine, FACTS, energy storage system (ESS), Renewable Energy, and HVDC system. He has published over 100 articles in different journals and international conferences. He has published five books as an author or editor. Dr. Mueen is the senior member of IEEE.



**Farid Khoucha** was born in Khenchela, Algeria, in 1974. He received the BSc, the MSc, and the PhD degrees all in Electrical Engineering, from the Ecole Militaire Polytechnique, Algiers, Algeria, in 1998, 2003, 2012 respectively.

In 2000, he joined the Ecole Militaire Polytechnique, Algiers, Algeria as a Teaching Assistant. Since January 2013, he is an Associate Professor. His current research interests include electric and hybrid vehicle control, energy management and smart grids.