



HAL
open science

Simulation and experimentation of an RFID system in the UHF band for the reliability of passive tags

Sanae Taoufik, Ahmed El Oualkadi, Farid Temcamani, B Delacressonniere, Pascal Dherbécourt

► **To cite this version:**

Sanae Taoufik, Ahmed El Oualkadi, Farid Temcamani, B Delacressonniere, Pascal Dherbécourt. Simulation and experimentation of an RFID system in the UHF band for the reliability of passive tags. MEDICT, 2015, SAIDIA, France. hal-01171801

HAL Id: hal-01171801

<https://hal.science/hal-01171801>

Submitted on 8 Jul 2015

HAL is a multi-disciplinary open access archive for the deposit and dissemination of scientific research documents, whether they are published or not. The documents may come from teaching and research institutions in France or abroad, or from public or private research centers.

L'archive ouverte pluridisciplinaire **HAL**, est destinée au dépôt et à la diffusion de documents scientifiques de niveau recherche, publiés ou non, émanant des établissements d'enseignement et de recherche français ou étrangers, des laboratoires publics ou privés.

Simulation and experimentation of an RFID system in the UHF band for the reliability of passive tags

S. Taoufik^(1,2), A. El Oualkadi⁽¹⁾, F. Temcamani⁽³⁾, B. Delacressonniere⁽³⁾,
P. Dherbécourt⁽²⁾

(1) Laboratory of Information Technology and Communication
National School of Applied Sciences of Tangier, university Abdelmalek Essaadi, Morocco

(2) Materials Physics Group, UMR CNRS 6634 university of Rouen
Avenue de l'université B.P 12 76801 Saint Etienne du Rouvray, France

Email: sanae.taou@gmail.com

(3) ECS-Lab EA3649 National School of Electronics and its applications
6 Avenue du Ponceau 95014 Cergy Pontoise, France

Abstract. In this article, we propose the simulation of architecture of a system RFID UHF for passive tags, using the Agilent Advanced Design System (ADS) software [1]. The implementation of this system requires two main parts, on one hand the reader simulation and on the other hand the tag. For that we use discrete components in order to allow at the same time a simple design and an optimization of the performances by providing UHF coverage and a power setting. Also temporal measurements, on a commercial system, allow us analyzing and validating the principles of communication between the reader and the tag. Finally, we propose the experimental measurement in order to evaluate the reliability of the tags aged thermally in stern operational conditions.

1. Introduction

Radio Frequency Identification (RFID) is a generic term used to describe a system which transmits an object or a person identity by using a radiofrequency link. Nowadays, the RFID technologies are used in many domains such transport, medical treatment, smart cards, and management of the supply chain...

Generally, RFID systems consist in two basic elements, a reader and a tag. The reader is constituted by a high-frequency module, a control unit and an antenna [2]. The tag attached to an object, consists in an antenna and a silicon chip, containing an identification code. According to the working frequency, RFID systems can be classified in four frequency bands: low frequencies (LF) around 125 kHz, high frequencies (HF) at 13.56 MHz, ultra-high frequencies (UHF) at 860-960 MHz, and the microwaves at 2.4 GHz [3]. For the LF and HF systems, the communication distance is lower than one meter. For UHF RFID systems, it reaches around five meters. The RFID systems are also classified according to the tag technology. The

passive tags which retro-modulate the wave received from the reader. They have no internal energy source and do not integrate RF transmitter. Active tags include an RF transmitter and a power supply source. The communication with the reader is a peer to peer type [4]. In this paper, we present the conception of a passive UHF RFID system.

EPC class1 Generation2: air interface protocol, first published by EPCglobal in 2004, defines the physical and logical requirements for an RFID system of interrogators and passive tags, operating in the 860 MHz - 960 MHz UHF range. Over the past decade, EPC class1 Gen2 has established itself as the standard for UHF implementations across multiple sectors, and is at the heart of more and more RFID implementations [5].

1. Description of the architecture of the RFID system

The reader consists in a transceiver, with an antenna that communicates with a passive tag. The tag returns by retro-modulation its identification code. The RFID system, shown in figure 1, is simulated using the co-simulation between the numeric front end and the radio front end.

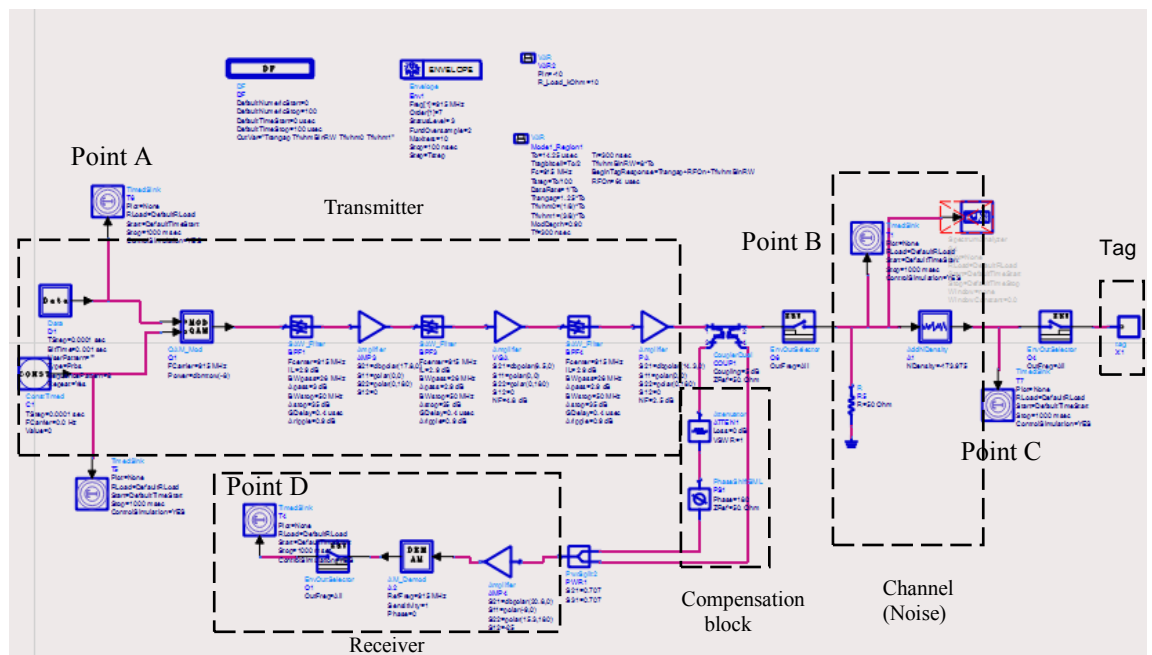

Fig1: block diagram of the RFID communication system

The transmitter part in the figure 1, is mainly made up of a digital data source and an ASK (amplitude shift keying) modulator with internal oscillator. Filtering

and amplification stages are also included, with bandwidth in the (860-960) MHz range. Filters are used to reject the out-of-band spectrum.

The receiver part is also presented in figure 1. The received signal is first amplified by a low-noise amplifier (LNA), and then filtered and demodulated by an ASK demodulator.

The emitted and received signals are separated by a directional coupler. A compensation block is implemented to attenuate and phase shift the signal in order to reduce, at the reception, the isolation defects [6].

The communication channel defect is modelled by an additive Gaussian filter to introduce sources of noise representing the environment.

Considering EPC Class 1 protocol, tags respond to the reader by retro-modulation sending the encode form signal shown in Figure 2. Two transitions are observed for a binary zero and four transitions are observed for a binary one during one elementary cell. The data rate of the returned signal is 140.35 kbps (in North America) and 30 kbps (in Europe)[6].

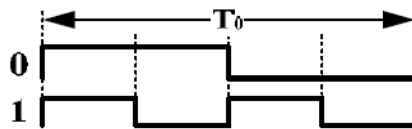

Fig2: EPC Class1 protocol signal encoding

2. Simulation results

In this section, we present significant simulation results for each part of the system. Figure 3 shows the simulation of PRBS (Pseudo Random Binary Sequence) data generated by the data-source from the reader transmitter (point A on Figure 1). The data rate is chosen equal to 100 Kbit/s corresponding to a bit time equal to $10\mu\text{s}$. Figure 4 shows the modulated signal (point B on Figure 1) using DSB-ASK (Double-sideband amplitude shift keying) modulation sent by the reader transmitter.

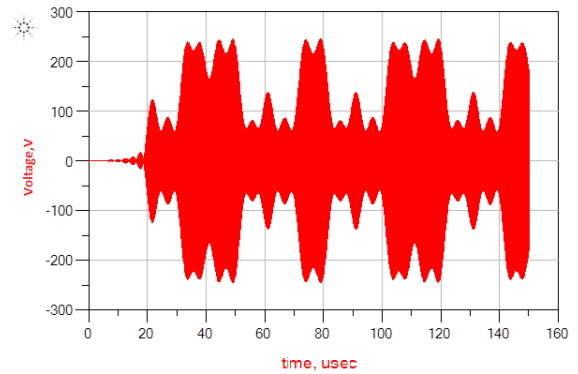
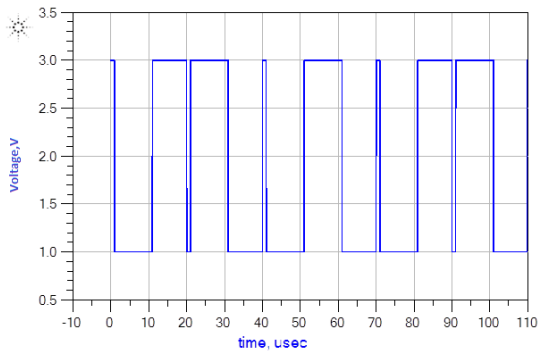

Fig3: Digital data to be transmitted Fig4: Carrier modulated by the data

Considering the operational working, the modulated signal is transmitted to the tag, which returns its coded identification. In order to simulate this process, the tag is considered as a data autonomous source. Figure 5 shows the encoded data sent by the tag (point C on Figure 1). Figure 6 (point D on Figure 1) shows the demodulated signal using the encoding according to Class 1 protocol. The data represent the binary sequence “111111100100001...”. The modulated signal is transmitted through the compensation bloc. The data are thus available at the output of the receiver circuit. Figure 6 shows that the received data correspond to the data sent by the tag in line with our expectations.

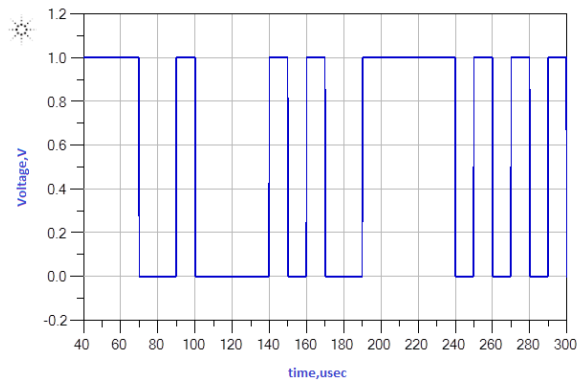
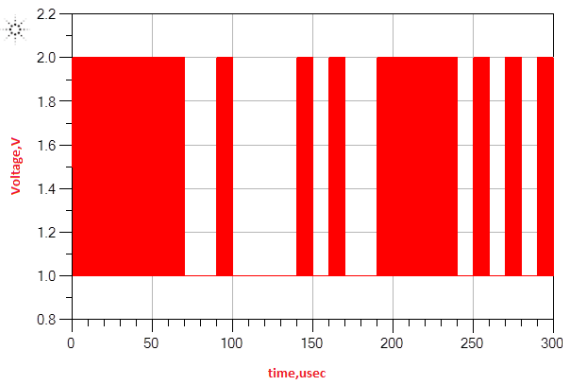

Fig5: Signal sent by the tag

Fig6: Signal received by the reader

3. Description of measuring bench

In order to study the robustness and the reliability of passive tags submitted to severe environmental constraints, we have developed a measurement bench depicted in Figure 7. The commercial reader SPEEDWAY[7] is controlled by the PC (hot), it is

connected to an antenna placed on a turntable 360°. The tag to be tested is placed on a stand disposed on a slide rail for a distance of up to 2 meters. Placed in an open environment of obstacles, this bench allows readings of the power reflected by the tag depending on the distance.

The bench can operate with four possible frequencies in the UHF band: 866.30MHz-866.90MHz-867.5MHz or 865.7MHz, the emitted power of the reader can reach 30dBm; the gain of the antenna is 6dBi.

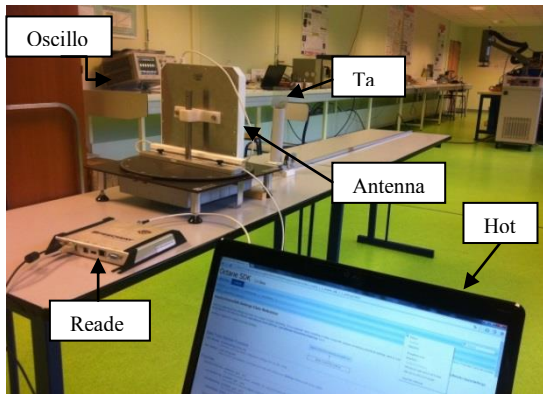

Fig.7.a: Vie of the test bench



Fig.7.b: Tag mounted on the sliding support

The passive tag chosen for this study is shown in the photograph in Figure 7.c. Its size is 40 mm x 54mm and it easily attaches to the object to be stored. It meets the requirements of EPC Class 1 Generation 2 (Gen 2) ISO 18 000-6C, and has an antenna attached to an integrated memory chip containing its unique identifier whose memory is 96 bits, or 12 bytes.

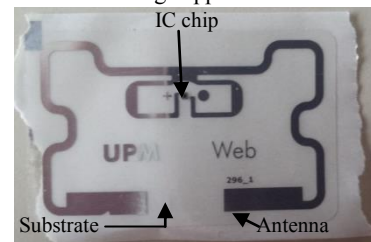

Fig.7.c:View of the UPM Web tag

4. Time measurements for the communication Reader / tag

Figure 8 shows chronograms recorded using the oscilloscope "Agilent Infinium" with a 6 GHz bandwidth, covering thereby the UHF range. Figure 8 shows the signal sent by the reader with the presence of a tag placed in the reading field. As expected, one can see a DSB-ASK modulation.

As shown in chronograms, part A of the signal represents the continuous wave (CW) signal suitable to feed the tag. Part B represents the instruction sent to the tag.

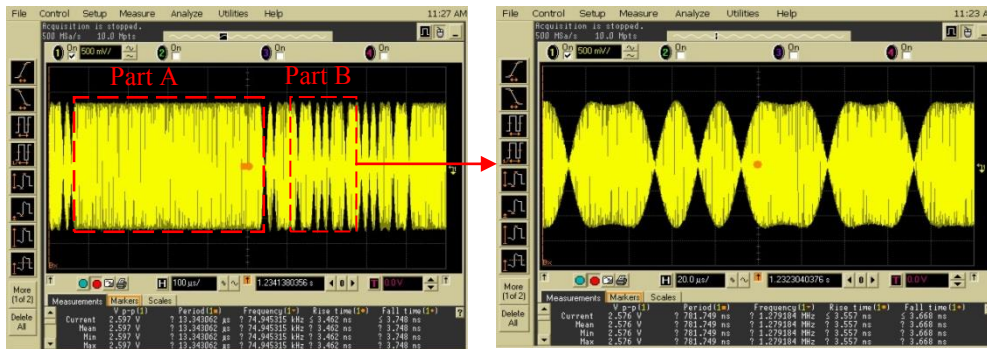

Fig.8: Time measurements for communication between reader /tag.

5. Measurements of the response of the tags

Using the bench describes in paragraph 3, some tests on tags are performed and presented in this section. The operating frequency band depends mainly on the RFID reader used. The chosen working frequency is 865.7MHz corresponding to the European norm. The reader generates a radio frequency signal transmitted by a SMA type cable to the antenna. The tag under test is positioned on a rail. The distance can be adjusted in a 200 cm range. It receives the signal and returns its identification code, the reflected power measured and displayed on the screen of a PC connected to the RFID reader.

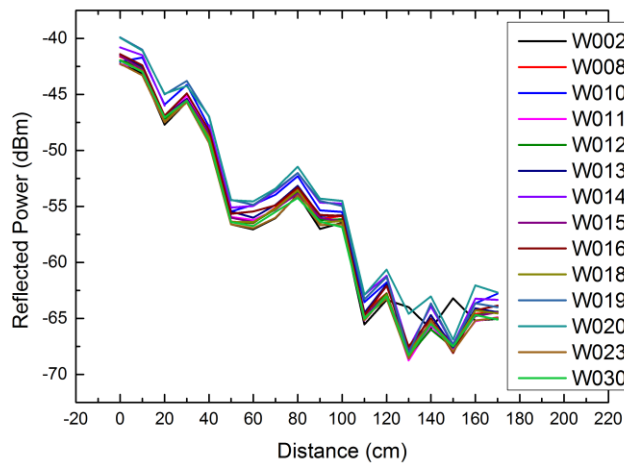

Fig.9: Reflected power by tags depended on distance.

Fourteen tags are tested; the results are shown in Figure 9. The power emitted by the reader is fixed to 27 dBm. The measurements reveal no significant variations of the reflected power for the different tags, showing a similar behavior. These results, show that the bench is fully operational to meet the needs of our study.

6. Conclusion and perspectives

Based on the simulations developed under ADS software, it is conceivable to consider the possibility of developing a reader based on discrete components. The system will be able to communicate with the tags to be tested by varying the transmit power and the frequency throughout the whole UHF band.

In order to evaluate the degradation of the tags performances, the measuring bench dedicated to power measurements is now operational and enables accurate measurements of the tags response. The tags have an operating temperature range between -40°C and 80°C . To study the impact of an accelerated aging, storage under high temperatures has been performed on three tags. The starting temperature was set at 100°C corresponding to an overtaking close to 20% of the maximum value recommended by the manufacturer. The step selected is 20°C ; storage time is 72 hours by step. As a result, for two temperatures equal to 100°C and 120°C , after the first tests, no significant variations of the performance of the tags are observed. More stringent aging conditions and new aging campaigns are underway. The purpose of this work is the study of the robustness and reliability of RFID systems in the UHF band under stern environmental conditions. A failure analysis will be implemented in order to accurately determine the type of defect. The metallization of the antenna should also be examined with an optical microscope to identify any cracks which might affect the performance of the tag. In addition, with a series of thirty devices, a statistical analysis using the predicted reliability calculation tools should be implemented.

Keywords: RFID, Passive tag, UHF band, simulation ADS, Reliability.

References

- [1] Agilent EEsof EDA, Advanced Design System, The Industry's Leading RF, Microwave and High-Speed Design Platform.
- [2] D. Dobkin, "The RF in RFID Passive UHF RFID in practice", Editor Elsevier, ISBN:978-0-7506-8209-1, 2008.
- [3] Ming K. Lim, Witold Bahr, Stephen C.H. Leung, "RFID in the warehouse: A literature analysis (1995–2010) of its applications, benefits, challenges and future trends." International Journal of Production Economics, Volume 145, Issue 1, Pages 409–430, September 2013.
- [4] P. Huet. L'identification par radiofréquence (RFID) techniques et perspectives, article invité, REE No.10, Novembre 2006.
- [5] EPC™ Radio-Frequency Identity Protocols, Generation-2 UHF RFID, Specification for RFID Air Interface, Protocol for Communications at 860 MHz – 960 MHz. Version 2.0.0 Ratified
- [6] Bin You, Bo Yang, Xuan Wen, and Liangyu Qu, "Implementation of Low-Cost UHF RFID Reader Front-Ends with Carrier Leakage Suppression Circuit", International Journal of Antennas and Propagation, Article ID 135203, 8 pages, 2013.
- [7] UHF GEN 2 RFID, SpeedwayR installation and operations guide version 5.2, Copyright © 2012 - 2014 Impinj, Inc. All rights reserved, <http://www.impinj.com>.
- [8] L. Jin, T. Cheng, "Analysis and Simulation of UHF RFID System", IEEE ICSP2006 Proceedings, 2006.
- [9] Huiyun Li. Development and Implementation of RFID Technology, chapter 1. I-Tech Education and Publishing, January 2009.