



HAL
open science

Power control of a photovoltaic system connected to a distribution frid in Vietnam

Xuan Truong Nguyen, Dinh Quang Nguyen, Tung Tran

► **To cite this version:**

Xuan Truong Nguyen, Dinh Quang Nguyen, Tung Tran. Power control of a photovoltaic system connected to a distribution frid in Vietnam. Vietnam Academy of Science and Technology Journal of Science and Technology, 2015, pp.331-336. hal-01166546

HAL Id: hal-01166546

<https://hal.science/hal-01166546>

Submitted on 23 Jun 2015

HAL is a multi-disciplinary open access archive for the deposit and dissemination of scientific research documents, whether they are published or not. The documents may come from teaching and research institutions in France or abroad, or from public or private research centers.

L'archive ouverte pluridisciplinaire **HAL**, est destinée au dépôt et à la diffusion de documents scientifiques de niveau recherche, publiés ou non, émanant des établissements d'enseignement et de recherche français ou étrangers, des laboratoires publics ou privés.

POWER CONTROL OF A PHOTOVOLTAIC SYSTEM CONNECTED TO A DISTRIBUTION GRID IN VIETNAM

Nguyen Xuan Truong^{1,*}, Nguyen Dinh Quang^{1,2}, Tran Tung¹

¹*Clean energy and sustainable development laboratory, Renewable energies department,
University of Science and Technology of Hanoi*

²*Institute of Energy Science, Vietnam Academy of Science and Technology*

*Email: nguyen-xuan.truong@usth.edu.vn

Received: May 10, 2015; Accepted for Publication: June 15, 2015

ABSTRACT

The demand for electrical energy is increasing in Vietnam in recent decades; which has motivated the use of renewable energy sources (RES). Among them, Photovoltaic (PV) energy is becoming a promising energy sources because of their advantages. The connection and use of PV in distribution grid in Vietnam should be in line with the framework of sustainable energy development worldwide. The different techniques of modeling and control of grid connected PV system with objective to help intensive penetration of PV electricity into grid have been proposed so far in different literatures. The current methodologies for optimizing of generation power of PV system are not completely efficient. Therefore many researches are required for overall configuration of the grid connected PV system, the Maximum Power Point Tracking algorithm, the synchronization of the inverter. This paper presents a control technique of the PV generation power by shift of phase angle of the inverter output voltage and grid voltage. In order to synchronize an alternative current output of the PV system's inverter into grid, the proposed method has been described, simulated in MATLAB/Simulink. The work helps to give a study results about interconnection standard, power generation optimization method of PV system into power grid.

Keywords: grid-connected PV systems, power control, interconnection standard, phase shifting

1. INTRODUCTION

Renewable energy sources such as solar energy, wind power, biomass and geothermal energy are abundant, inexhaustible and widely available. The development and use of renewable energy sources can enhance diversity in energy supply markets, contribute to securing long-term sustainable energy supplies, and help reduce local and global environmental impacts. Photovoltaic (PV) power system has attracted the interest of governments, industry and researchers alike due to its zero greenhouse gas emission. It consisting of solar cells converts sun light into electricity through the photoelectric effect. This system is being used regularly to supply electricity to individual and/or grid-connected systems. Grid-connected PV systems have many technical advantages such as flexibility, simplicity to install in many area where the solar

irradiation is available, being non-polluting, emitting no noise and requiring little maintenance [1]. The PV system shows a non linear current-voltage characteristics varying with the irradiance and temperature which affects its power output. It is normally used a maximum power point tracking (MPPT) technique to continuously deliver highest possible power in different conditions. The MPPT control is critical for the success of a PV generation system [2]. In application of PV system connected to the grid, the core technology associated with PV system is an *inverter* unit that converts the solar output electrically (DC voltage) to the utility grid (AC voltage) with nominal specification same with grid's specification (angle, frequency, amplitude).

The main purpose for PV grid-connected system is to control the power flow between the primary renewable energy source and the grid, as well as the power factor of PV inverter-grid connection with high power quality [3-5]. This paper is organized in the following manner: Section 2.1 introduces the basic operation principle of the PV grid-connected system. Section 2.2 describes the control strategy based on the phase shifting of the inverter output voltage. Section 3 shows the simulation results demonstrating the validity and performance of the control strategy. Conclusions are finally drawn in the last section. We focus only on the interconnection and use of PV in low-voltage grid for household's application. The voltage output of the PV grid-connected inverter must be obeys the standards given by the power company in general, such as safety conditions, grid's specification, and synchronization conditions [6].

2. GRID-CONNECTED PV GENERATION SYSTEM

2.1 Operational principle

Figure 1(a) shows the configuration of the grid-connected PV system for single-phase inverter composed by a DC/DC Boost converter, and in cascaded with an inverter DC/AC. The DC/DC Boost converter performs MPPT for maximizing the output power of PV array to fully utilize the PV power and voltage boost to match that of grid inverter. The boost converter controls the PV array operating point by the switch duty command, and the post single phase inverter controls the DC-link capacitor voltage C_{PV} and controls the output current to be in-phase with the grid voltage. Then a single-phase buck DC/AC inverter with four power switches IGBT is used to step down and to modulate the output voltage according to the grid voltage ($\pm 10^\circ$, 49.7÷50.3 Hz, and 220 Vrms $\pm 10\%$). Power switches are controlled by a pulse-width modulation (PWM) technique to open and close in low and supply AC voltage to the grid. Commonly, energy storage elements, such as the DC-link capacitor C_{DC} , are used to compensate the difference between the DC power from the PV array and the time-varying instantaneous power absorbed by the grid. The filter $L_f C_f$ is designed to reduce high-order harmonics introduced by the sinusoidal pulse generator of the DC/AC inverter. Moreover, the control of the power flow to the grid, according to the European standards (*EN 61727*), is based on the control of active and reactive power [3, 6]. The shortage of load power from the PV array is supplemented by the grid. On the contrary, the excessive power from the PV array to the load can be fed to the grid. The balance of power flow is controlled through the inverter.

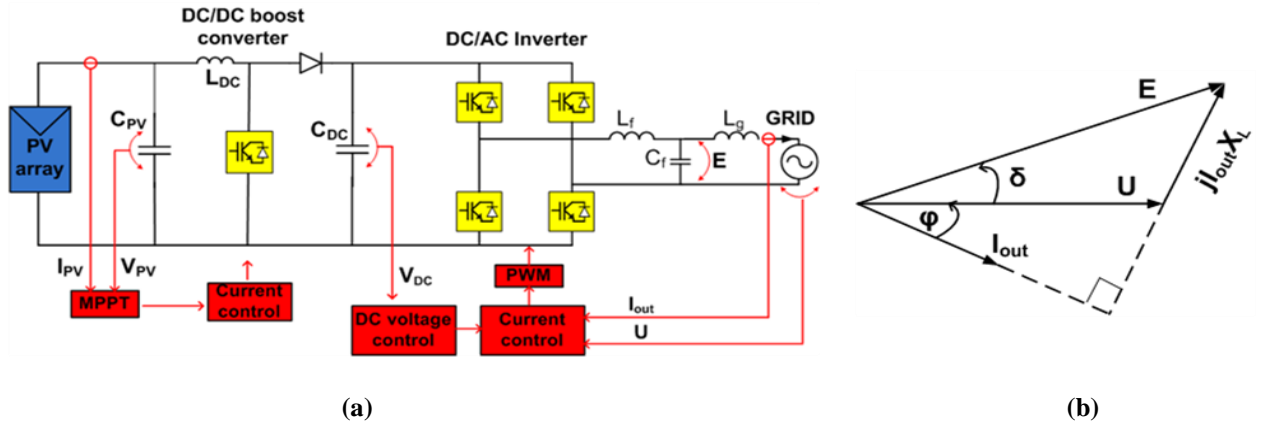

Figure 1. Single-phase inverter connected to the grid (a), Phase diagram of E , V_L , I_{out} , U and angle δ (b)

2.2. Power control method for a single phase grid-connected PV generation system

2.2.1 Grid-connected inverter control description

The characteristics of the circuit can be understandable when see on the Figure 1(b), which represents the phase diagram of the fundamental components, including the inverter output voltage (E), the inverter output current (I_{out}), the drop voltage on the inductance L ($V_L = jX_L I_{out}$), and the fundamental component of the grid (U) [4, 5].

φ is power angle the phase shift between the grid voltage and the inverter output current. And, δ represents for phase shift between inverter output voltage (E) and grid voltage (U). The following equation can be expressed, according to the figure 1:

$$\overset{*}{E} = \overset{*}{U} + \overset{*}{V}_L = \overset{*}{U} + jX_L \overset{*}{I}_{out} \quad (1)$$

$$E \sin \delta = V_L \cos \varphi = X_L I_{out} \cos \varphi \quad (2)$$

The active power (P) output of inverter inject to grid can be expressed as following:

$$P = UI_{out} \cos \varphi = \frac{U \cdot E \sin \delta}{X_L} \quad (3)$$

And the reactive power (Q) provided by the converter to the grid can be represented:

$$Q = U \cdot I_{out} \sin \varphi \quad (4)$$

$$X_L \cdot I_{out} \cdot \sin \varphi = E \cos \delta - U$$

$$Q = \frac{U(E \cos \delta - U)}{X_L} \quad (5)$$

Base on the figure (1) and equation (3), it can seen that the active power inject in to grid will be affected by the variable of grid voltage (U), inverter output (E), inductance L and also the shift angle (δ) between inverter output voltage and grid voltage. On the other hand, to inject power into grid, the value of the DC voltage must be high enough so that the output voltage E can get a value which is equal or greater than the grid peak voltage.

It can also be deduced that active power (P) can be controlled by change the value of amplitude of E and the phase shift (δ). However, the injected power into grid affected direct proportional by the grid voltage (U). So, the PV energy send into grid will be changed if the amplitude of U variation. According to equation (5) at the same time, the reactive power can be controlled by the inverter output voltage magnitude (E) [2-6].

2.2.2 Power control structure for single-phase Grid-connected PV

The control structure for a single-phase inverter grid-connected is shown in the figure 2(a) [2-6]. The system is composed of a PV array, a DC/DC converter with MPPT controller, a PWM single-phase inverter DC/AC, and an active and reactive power controller. The control circuit consists of two stages. The front stage controls the active power injected and/or absorbed into grid by the phase shift (δ), and the latter stage controls the reactive power through the inverter output voltage magnitude (E). The control structure is associated with proportional-integral (PI) controllers since they have a satisfactory behavior when regulating DC variables. As show in figure 2(a), the capacity of PV source (P_r),-the reference signal, is compared with output active power of inverter P_g which produced by the controller, generating an active power error. This different active power through PI controller, the principle of controller is repeat that the higher or lower of active power is injected into grid will be adjusted by reducing or increasing the value of $\sin(\delta)$ in order to keep equation (3) constant. Resulting is corresponding shift angle δ . This angle is then added to phase-angle of grid voltage (θ_u), and generate output voltage phase-angle of inverter is $(\delta + \theta_u)$. On the other hand, the controller compensate the reactive power injected into the grid (Q_g) and compares it with its reference Q_r , - the output capacity of PV inverter, originating an reactive power error. This value pass the other PI controller, the output that is suitable voltage ΔE is added to grid voltage amplitude U_m . The output voltage amplitude E_m is result of this processing. The amplitude E_m is multiplied by $\sin(\delta + \theta_u)$, the output of inverter is represented below:

$$e = E_m \sin(\delta + \theta_u) \text{ , where } E_m = U_m + \Delta E \quad (6)$$

This control strategy is implementation at control circuit at digital sinusoidal pulse width modulation. We shift the time generate pulse which to active open IGBT, the method creates the delays the time generate pulse is t (second). The time (t) is calculated as below:

$$t = T - \frac{\delta T}{360^\circ} = T(1 - \frac{\delta}{360^\circ}) \quad (7)$$

Where, (t) the shifting time correspond to shift angle δ° , and (T) the period of grid voltage. At that time we have the inverter voltage output earlier than grid voltage shift angle is δ° .

3. SIMULATION RESULTS AND DISCUSSION

In this report we assign a constant value to output voltage of PV source, this is responsibility of MPPT technique and DC/DC Boost converter. So it is working as constant DC source. Matlab/simulink software were used in all simulations, which shows the results obtained for voltage waveform, active, reactive and apparent powers on the AC side supplied to the grid. The rate value of grid voltage ($U = 220$ Vrms) and the inverter is connected to the grid through a coupling inductance $L_g = 10$ mH. A simulation at low power scale (less than 3 kW) is implemented in predicting the behavior of the system for experiments will be performed on our laboratory test bench and because it is suitable for household scale.

3.1. Variation of load

Figure 2(b) represented how inverter output power and grid power influence by local load variation. In this situation, the inverter is connected to grid at 0.02 (sec) without load, it can be seen the output active power of inverter ($P_{Int} = 732$ watt) is injected into grid fully, pink curve is the active power of grid receive or inject to load. At 0.08 sec to 0.16 sec, the load is connected to system with 242 watt, it can be seen that the red curve is represented for power of load by time. During this period the grid receive less power from inverter, the power reduction equal load power. At 0.16 sec the load demand increase to 1500 watt, over the capacity of inverter, the local load consumes power on both inverter and grid site. The output power of inverter is stable although power of load change.

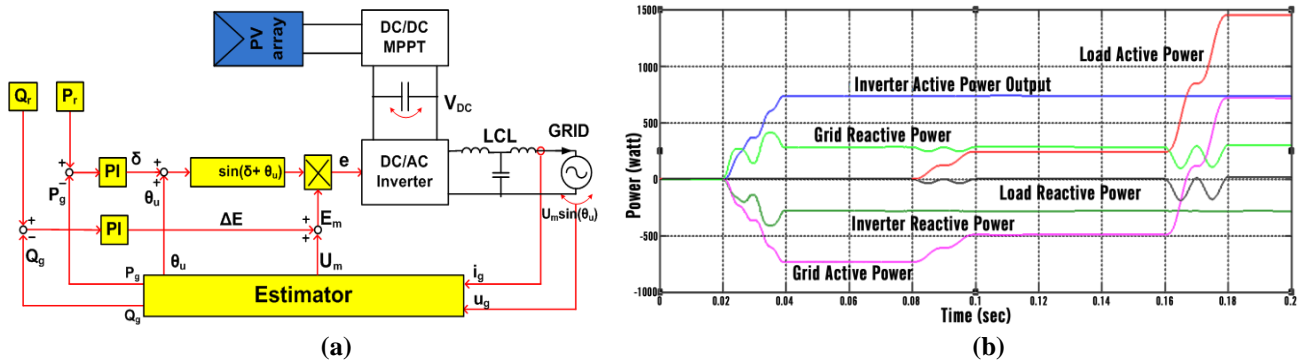

Figure 2. Control structure for a single phase grid-connected PV system (a) [2-5], Inverter output power and grid power respond to variation of local load (b)

3.2. Variation of grid voltage

The Figure 3(a) shows behavior of output power of inverter corresponding to grid voltage. The grid voltage is kept at 220 volt until 0.04 sec, inverter inject active power to grid is 667 watt as shows on red curve. At 0.04 sec the grid voltage is reduced to 200 volt, the corresponding inverter power output is reduced to 623 watt. At 0.08 sec, the grid voltage is increase to 240 volt, the inverter power output is increase to 672 watt. The grid receives active power is represented by blue curve, amounts of power equal to output power of inverter at correspond time.

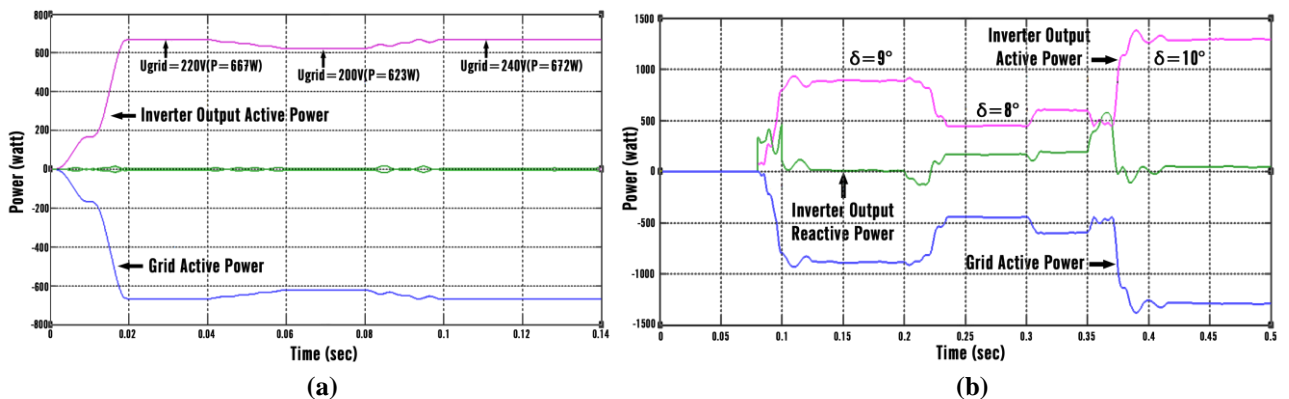

Figure 3. Inverter output power and grid power respond to variation of grid voltage (a), and respond to variation shift angle δ (b)

3.3. Variation of shift angle between inverter voltage and grid voltage

The relation between inverter output power and shifting angle δ are represented by red curve in Figure 3(b). Inverter is controlled to inject power into grid at 0.08 sec, it take a 0.1 sec to reach stable and keep constant around 900 watt correspond at $\delta=9^\circ$ until 0.2 sec. At that time we control the δ reduce from 9° to $\delta = 8^\circ$, result is output inject in to grid is fluctuated and stable at lower value around 500 watt. At 0.3 sec, we increase δ to 10° , the output power increase back and stability around 1300 watt. On the other hand, the blue curve show the grid absorb power, and this value as same as output power of inverter.

4. CONCLUSIONS

This work presented the power control shifting phase technique for controlling a power of the single phase grid-connected PV system, which controls inverter output power by control the phase angle δ between PV inverter output voltage and grid voltage. This control strategy does not require complicated device, it is foundation for promotes low cost grid-connected PV system. It allows controlling not only an active power needs to be injected into grid but also a reactive power. When the reactive power reference is zero, the power factor will approach to the unity. The modeling and simulation of a single-phase grid-connected PV system was carried. The simulation results express quite clear the behavior of inverter output how influence by variation of grid voltage, the phase angle δ between the inverter output voltage respect to the grid voltage and loader. The results are explainable by theory and also it help to give a study about interconnection standard of PV system into power grid. In addition, the results of test in real time were being carried out on experimental bench in our laboratory with the real conditions (solar radiation, grid conditions, load conditions). The experimental results were corresponding to the proposal control method and simulation results.

5. REFERENCES

1. Makrides G, Zinsser B, Norton M, Georghiou G, Schubert M, and Werner J. – Potential of photovoltaic systems in countries with high solar irradiation, *Renewable Sustainable Energy. Reviews.* **15** (2010), pp. 754-762.
2. Hassaine L, Olias E, Quintero J, and Barrado A. – Power control for grid connected applications based on the phase shifting of the inverter output voltage with respect to the grid voltage, *Electrical Power and Energy Systems.* **57** (2014), pp. 250-260.
3. Guerrero-Rodriguez N. F, Herrero-de Lucas L. C, Alexis. B. Rey-Boué, and Martinez-Rodrigo F. – Control and synchronization algorithms for a grid-connected photovoltaic system under harmonic distortions, frequency variation and unbalances, *Electric Power Systems Research* **80** (2015), pp. 380-395.
4. Rezapour E, Tavakoli Bina Md, Hajizadeh A. – Active and reactive power controller for single phase connected photovoltaic systems, *International Journal of Emerging Science and Engineering.* **2** (5) (2014), pp. 22-24.
5. Tran-Cong B, Mai-Tuan D, Ngo-Manh D, Phan-Quang A, Pham-Dinh T and Nguyen-Huu P. – Active and reactive power controller for single-phase grid-connected photovoltaic systems, *Proceedings of AUN-SEEDNet Conference on Renewable Energy- Bandung-Indonesia, March* (2009).
6. IEEE Standard for Interconnecting distributed resources with electronic power systems, *IEEE 1547-1*, (2005).