



**HAL**  
open science

# The chemical approach to typestate-oriented programming

Silvia Crafa, Luca Padovani

► **To cite this version:**

Silvia Crafa, Luca Padovani. The chemical approach to typestate-oriented programming. 2015. hal-01155682v1

**HAL Id: hal-01155682**

**<https://hal.science/hal-01155682v1>**

Preprint submitted on 27 May 2015 (v1), last revised 5 Aug 2015 (v2)

**HAL** is a multi-disciplinary open access archive for the deposit and dissemination of scientific research documents, whether they are published or not. The documents may come from teaching and research institutions in France or abroad, or from public or private research centers.

L'archive ouverte pluridisciplinaire **HAL**, est destinée au dépôt et à la diffusion de documents scientifiques de niveau recherche, publiés ou non, émanant des établissements d'enseignement et de recherche français ou étrangers, des laboratoires publics ou privés.

# The chemical approach to tpestate-oriented programming

Silvia Crafa

Università di Padova, Italy  
crafa@math.unipd.it

Luca Padovani

Università di Torino, Italy  
luca.padovani@di.unito.it

## Abstract

We study a novel approach to tpestate-oriented programming based on the chemical metaphor: state and operations on objects are molecules of messages and state transformations are chemical reactions. This approach allows us to investigate tpestate in an inherently concurrent setting, whereby objects can be accessed and modified concurrently by several processes, each potentially changing only part of their state. We introduce a simple behavioral type theory to express in a uniform way both the private and the public interfaces of objects, to describe and enforce structured object protocols consisting of possibilities, prohibitions, and obligations, and to control object sharing.

**Categories and Subject Descriptors** D.1.3 [Concurrent Programming]; D.2.4 [Software/Program Verification]: Class invariants; F.3.3 [Studies of Program Constructs]: Type structure

**Keywords** Tpestate, Concurrency, Behavioral Types, Join Calculus

## 1. Introduction

In an object-oriented program, the *interface* of an object describes the whole set of methods supported by the object throughout its entire lifetime. However, the usage of the object is more precisely explained in terms of its *protocol* [2], describing the sequences of method calls that are legal, possibly depending on the object's internal state. Typical examples of objects with structured protocols are files, iterators, and locks: a file can be read or written only after it has been opened; an iterator can be asked to access the next element of a collection only if such element has been verified to exist; a lock should be released if (and only if) it was previously acquired. Usually, such constraints on the legal sequences of

method calls are only informally documented as *comments* along with method descriptions; in this form, however, they cannot be used by the compiler to detect protocol violations.

In [12], DeLine and Fähndrich have adapted the concept of *tpestate* [26], originally introduced for imperative programs, to the object-oriented paradigm. Tpestates are machine-understandable abstractions of an object's internal state that can be used (1) to identify the subset of fields and operations that are valid when the object is in some given state and (2) to specify the effect of such operations on the state itself. For example, on a file in state CLOSE the compiler would permit invocations of the open method and forbid invocations of the read method, whereas on a file in state OPEN it would only permit invocations of read, write, and close methods and forbid open. Furthermore, the type of open would be refined so as to specify that its invocation changes the state of the file from CLOSE to OPEN. Tpestate-oriented programming (TSOP for short) [1, 9, 17, 27] goes one step further and promotes tpestates to a native feature of the programming language that encourages programmers to design objects around their protocol. Languages supporting TSOP provide explicit constructs for defining state-dependent object interfaces and for changing and possibly querying at runtime an object's tpestate.

Tpestate information is useful as long as the compiler can track with sufficient precision the points in the code where the state of an object changes, and so does its interface. Consequently, all languages with tpestate rely on more or less sophisticated forms of aliasing control [5] which may hinder the applicability of tpestate to *concurrent objects*. Damiani *et al.* [9] have shown how to conjugate tpestate and concurrency relying on some runtime support: users of an object can invoke methods at any time; a method invocation blocks if the object is in a state for which that method is illegal; tpestate information is used *within* methods, to make sure that only valid fields are accessed. This approach has both computational and methodological costs: it forces all methods of a concurrent object to be synchronized, and it guarantees protocol compliance only within methods, where some form of aliasing control can be used.

In the present paper we put forward a radically different approach to TSOP and make the following contributions.

(1) We approach TSOP in an *inherently concurrent* setting, whereby objects can be shared and accessed concurrently, and (portions of) their state can be changed while they are simultaneously used by several processes. As suggested by [9], such setting requires support from the runtime environment. However, in our case the extent and kind of concurrency allowed on objects is tuned by the type system: shared/aliased objects rely on *runtime synchronization* to resolve races and execute methods at the right time; non-aliased objects fully benefit from *static typestate checking*; the typing of objects regulates the tradeoff between these extremes and enables a whole range of intermediate scenarios.

(2) Instead of extending an existing object-oriented language with concurrency and support for TSOP, we adopt a basic model of concurrent objects where method definition relies on the *explicit coupling of state with operations*. Quite remarkably, such model is provided out-of-the-box by the Objective Join Calculus [14, 15], a calculus well-known in the process algebra community that originates as a viable model of distributed communication. Not only we show that the Objective Join Calculus is also a natural and simple model for TSOP, but we observe that it natively supports high-level concepts such as *compound* and *multidimensional* states [27]. This allows us to formally investigate the issues arising when states are partially/concurrently updated.

(3) In the Objective Join Calculus both state and operations are modeled using the same feature: *messages*. Thus, we are able to describe in a uniform and compositional way the encapsulated part of objects (state), their public interface (operations), as well as their protocol using a simple language of *behavioral types* with an intuitive semantics: the type of an object denotes the set of message configurations that are legal according to its protocol. Such interpretation induces a *subtyping relation* that serves multiple purposes: aside from realizing the obvious form of subtype polymorphism, it provides – at no additional cost – a key tool for deriving the protocol of objects with uncertain state. On objects without typestates, subtyping collapses to the traditional one.

**Structure of the paper.** We start with an informal overview of TSOP in the Objective Join Calculus (Section 2) before presenting its syntax and semantics (Section 3). Then, we define syntax and semantics of types (Section 4), we describe the rules of the type system (Section 5), and comment on its safety properties (Section 6). We conclude with a more detailed discussion of closely related work (Section 7) and future research directions (Section 8). *Proofs of the results can be found in the appendix, beyond the page limit.*

## 2. The chemistry of typestates

**The chemical metaphor.** The Join Calculus [14, 15] originates from the Chemical Abstract Machine [4], a formal model of computations as sequences of chemical reactions transforming molecules. The Objective Join Calculus [16] is a mildly sugared version of the Join Calculus with object-

```

1 def o = FREE | acquire(r) ▷ o.BUSY | r.reply(o)
2   or   BUSY | release  ▷ o.FREE
3 in o.FREE
4 | def c = reply(o') ▷ o'.release in o.acquire(c)

```

**Listing 1.** A lock in the Objective Join Calculus.

oriented features: a program is made of a set of *objects* and a *chemical soup* of messages that can combine into complex molecules; each object consists of *reaction rules* corresponding to its methods; reaction rules are made of a *pattern* and a *body*: when a molecule in the chemical soup matches the pattern of a reaction, the molecule is consumed and the corresponding body produces other molecules.

Listing 1 shows the idiomatic implementation and use of a *lock* in the Objective Join Calculus. The definition on lines 1-2 creates a new object *o* with two reaction rules, separated by `or`. The symbol  $\triangleright$  separates the pattern from the body of each rule, while `|` combines messages into complex molecules. The first reaction “fires” if a `FREE` message and an `acquire` message (with argument *r*) are sent to *o*: the two messages are consumed and those on the right hand side of  $\triangleright$  are produced. In this case, the argument *r* of `acquire` is a reference to another object representing the process that wants to acquire the lock. Hence the effect of triggering the first reaction is that a `BUSY` message is sent to *o* (in jargon, to “self”) and a `reply` message is sent to *r* to notify the receiver that the lock has been successfully acquired. The second reaction specifies that the object can also consume a molecule consisting of a `BUSY` message and a `release` message. The reaction just sends a `FREE` message to *o*. The lock is initialized on line 3, by sending a `FREE` message to *o*.

The process on line 4 shows a typical use the lock. Since communication in the Join Calculus is asynchronous, sequential composition is modeled by means of *continuation passing*: the process creates a continuation object *c* that reacts to the `reply` message sent by the lock; then, the process manifests its intention to acquire the lock by sending `acquire(c)` to *o*. When the reaction on line 1 fires, the `reply` triggers the reaction in *c* on line 4, causing the lock to be released. One aspect not explained in the above description is the passing of *o* in the `reply` message on line 1 which is bound to *o'* on line 4. Since on line 1 *o* corresponds to “self”, sending *o* in the message `reply(o)` enables *method chaining*. In fact, with some appropriate syntactic sugar we could rewrite the process on line 4 just as

```
o.acquire.release
```

We will introduce a generalization of such syntactic sugar later on (see Example 3.2 and Listing 3). We will also see that method chaining is not just a trick for writing compact code, but is a key feature that our type system hinges on.

In the next section we will discuss a more complex use case (Example 3.3) where the lock defined in lines 1-2 is

shared by two processes that compete for acquiring it. In that case, we will see that the complex molecules in the patterns of the lock’s reaction rules are essential to make sure that the lock behaves correctly, namely that only one process can hold the lock at any time. In particular, if an `acquire(c’)` message is available but there is no `FREE` message in the soup (because another process has previously acquired the lock thereby consuming `FREE`), the reaction in line 1 cannot fire and the process waiting for the `reply` message on `c’` blocks until the lock is released.

**State and operations in the Join Calculus.** Listing 1 provides a clear illustration of TSOP in the Join Calculus: a lock is either free or busy; it can only be acquired when it is free, and it can only be released when it is busy; acquisition makes the lock busy, and release makes it free again. The compound molecules in the patterns specify the valid combinations of state and operations, and the state is explicitly changed within the body of reactions.

These observations lead to a natural classification of messages in two categories: `FREE` and `BUSY` encode the *state* of the lock, while `acquire` and `release` represent its *operations* (we follow the convention that “state” messages are written in upper case and “operation” messages in lower case). Ideally, lock users should not even be aware of the existence of `FREE` and `BUSY`, if only to prevent accidental or malicious violations of the lock protocol. Our type system will enforce an encapsulation mechanism to prevent users from sending state messages (Section 5).

Messages in the chemical soup encode the current state of the object and the (pending) operations on it: for instance, the presence of a message `o.FREE` in the soup encodes the fact that the object `o` is in state `FREE`; the presence of a message `o.acquire` in the soup encodes the fact that *there is a pending invocation* to the `acquire` method of the object `o`. Representing state using (molecules of) messages makes it simple to model so-called *and-states* [27], which we will see at work in Example 5.8. On the contrary, `FREE` and `BUSY` are examples *or-states* which mutually exclude each other. The typing of the lock object will guarantee that there is always exactly one message among `FREE` and `BUSY`, *i.e.* that the state of the lock is always uniquely determined.

**Behavioral types for the Join Calculus.** Since in the Join Calculus there is no sharp distinction between (private) messages that encode the object’s state and (public) messages that represent the object’s operations, we can devise a type language to describe the legit configurations of messages, both private and public, that objects can/must handle. In fact, we can use types to specify (and enforce) the object protocol. Object types are built from message types  $m(\tilde{t})$  using three behavioral connectives, the *product*  $\otimes$ , the *choice*  $\oplus$ , and the *exponential*  $*$ . An object of type  $m(\tilde{t})$  *must* be used for sending an  $m$ -tagged message with a (possibly empty) tuple of arguments of type  $\tilde{t}$ ; an object of type  $t \otimes s$  *must* be used **both** as specified by  $t$  **and** as specified by  $s$ ; an object

of type  $t \oplus s$  *must* be used **either** as specified by  $t$  **or** as specified by  $s$ ; an object of type  $*t$  *can* be used any number of times (even zero), each time as specified by  $t$ .

As an example, let us illustrate the type of the lock object. It is useful to keep in mind the intuition that the type of the lock should describe the whole set of legit configurations of messages targeted to the lock. In this respect, we recall that:

- there *must* be exactly one message among `FREE` and `BUSY` that encodes the state of the lock;
- there *can* be an arbitrary number of `acquire` messages regardless of the state of the lock (the lock is useful only if it is shared among several processes);
- there *must* be one `release` message if the lock is `BUSY` (this is an eventual obligation).

We express all of these constraints with the type

$$t_{lock} \stackrel{\text{def}}{=} *acquire(reply(release)) \otimes (FREE \oplus (BUSY \otimes release))$$

It is no coincidence that the only occurrence of  $*$  is used in front of the only message (`acquire`) for which there are no obligations: the lock *can* be acquired, but it is not mandatory to acquire it. However, if the lock is acquired, then it *must* be released; whence the lack of  $*$  in front of `release`. There is no  $*$  in front of `FREE` and `BUSY` either, meaning that there is an obligation to produce these messages too, but since `FREE` and `BUSY` occur in different branches of a  $\oplus$  type, only one of them must be produced. In addition to possibilities and obligations,  $t_{lock}$  expresses prohibitions: all message configurations containing multiple `FREE` or `BUSY` messages or both `FREE` and `release` messages are prohibited by the type. Our type system will guarantee that any lock object is always in a configuration that is legal according to  $t_{lock}$ . This implies, for example, that a well-typed process never attempts to release a lock that is in state `FREE`.

There is one last thing to discuss before we end this informal overview, that is the type of the argument of `acquire`, named `r` in Listing 1. If we look at the code, we see that `r` is the reference to an object to which the lock sends a `reply(o)` message. Not surprisingly then, the argument of `acquire` has type `reply(release)` in  $t_{lock}$ . This means that the reference `o’` in Listing 1 has type `release`, which is consistent with the way it is used on line 4. In other words, we use method chaining to express the change in the (public) type of an object as methods are invoked. Both `o` and `o’` refer to the same lock object, but they have different interfaces: the former can be used for acquiring the lock; the latter must be used (once) for releasing it.

### 3. The Objective Join Calculus

The syntax of the Objective Join Calculus is defined in Table 1. We assume countable sets of *object names*  $a, b, c, \dots$  and of *variables*  $x, y, \dots$ . We let  $u, v, \dots$  denote

$P, Q ::=$	<code>null</code> <code>  u . M</code> <code>  P   Q</code> <code>  def a = C in P</code>	<b>Process</b> (null process) (message sending) (process composition) (object definition)
$M, N ::=$	<code>m(<math>\tilde{u}</math>)</code> <code>  M   N</code>	<b>Molecule / Pattern</b> (message) (molecule composition)
$C, D ::=$	<code>J <math>\triangleright</math> P</code> <code>  C or D</code>	<b>Class</b> (reaction rule) (class composition)

**Table 1.** Syntax of the Objective Join Calculus.

names, which are either object names or variables, and use  $m, \dots$  to range over *message tags*. We write  $\tilde{u}$  for a (possibly empty) tuple  $u_1, \dots, u_n$  of names; we will use this notation extensively for denoting tuples of various entities. In a few occasions, we will also use  $\tilde{u}$  as the set of names in  $\tilde{u}$ .

The syntax of the calculus comprises the syntactic categories of *processes*, *molecules*, and *classes*. Molecules are assemblies of messages and each message  $m(\tilde{u})$  is made of a tag  $m$  and a tuple  $\tilde{u}$  of arguments; we will abbreviate  $m()$  with  $m$ ; *join patterns* (or simply patterns)  $J, \dots$  are molecules whose arguments are all variables, and variables and message tags occurring in them are pairwise distinct. This *linearity condition* of patterns is typical of most presentations of the Join Calculus and is usually motivated by efficiency reasons. In our case, it is necessary for the soundness of the type system (see Remark 5.4).

The process `null` is inert and does nothing. The process `u . M` sends the messages in the molecule  $M$  to  $u$ . The process `P | Q` is the parallel composition of  $P$  and  $Q$ . Finally, `def a = C in P` creates a new instance  $a$  of the class  $C$ . The name  $a$  is bound both in  $C$  (where it plays the role of “self”) and in  $P$ . A class is a disjunction of *reaction rules*, which we will often represent as a set  $\{J_i \triangleright P_i\}_{i \in I}$ . Each rule consists of a *pattern*  $J_i$  and a *body*  $P_i$ . The variables in  $J_i$  are bound in  $P_i$ . An instance of  $P_i$  is spawned each time a molecule matching  $J_i$  is sent to an object that is instance of the class.

We omit the formal definition of free and bound names, which can be found in [16]. We write  $\text{fn}(P)$  for the set of free names in  $P$  and we identify processes up to renaming of bound names. In this paper we use an additional constraint, which is not restrictive and simplifies the type system: we require classes to have no free names other than “self”.

We now turn to the operational semantics of the calculus, which describes the evolution of a *solution*  $\mathcal{D} \Vdash \mathcal{P}$  made of a set  $\mathcal{D} = \{a_i = C_i\}_{i \in I}$  of object definitions and a multiset  $\mathcal{P}$  of parallel processes. Intuitively,  $\mathcal{P}$  is a “soup” of pro-

```

1 def ArrayIterator = new(a,r)  $\triangleright$ 
2   def o =
3     INIT(a,n)  $\triangleright$ 
4     if n < #a then o.SOME(a,n) else o.NONE
5   or SOME(a,n) | next(r)  $\triangleright$ 
6     o.INIT(a,n+1) | r.reply(a[n],o)
7   or SOME(a,n) | peek(r)  $\triangleright$  o.SOME(a,n) | r.some(o)
8   or NONE      | peek(r)  $\triangleright$  o.NONE      | r.none(o)
9   in o.INIT(a,0) | r.reply(o)
10 in ...

```

**Listing 2.** An array iterator.

cesses and molecules that is subject to changes in the temperature (expressed by a relation  $\rightleftharpoons$ ) and reactions (expressed by a relation  $\rightarrow$ ). Heating  $\rightarrow$  breaks things apart, while cooling  $\leftarrow$  recombines them together, in possibly different configurations. Heating and cooling are reversible transformations of the soup, defined by the first four rules in Table 2: rule [NULL] states that `null` processes may evaporate or condense; rule [DEF] moves objects definitions to/from the  $\mathcal{D}$  component of solutions, having care not to capture free names (disposing of a countable set of object names, we can always silently perform suitable alpha-renamings to avoid captures); rule [COMP-1] breaks and recombines processes and rule [COMP-2] does the same with molecules. In all the rules we omit definitions and processes unaffected by the relation. Rule [RED] defines reactions as non-reversible transformations of the soup. A reaction may happen whenever the soup contains a molecule targeted to some object  $a$  such that the shape of the molecule matches the pattern of one of the rules in the class of  $a$ , up to some substitution  $\sigma$  mapping variables to object names. In this case, the molecule is consumed by the reaction and replaced by the body of the rule, with the substitution  $\sigma$  applied.

In the rest of the section we illustrate the calculus by means of examples. For better clarity, we augment the calculus with conditionals and a few native data types, which can be either encoded or added without difficulties.

**Example 3.1** (iterator). Listing 2 shows a possible modeling of an array iterator class in the Objective Join Calculus. Like in object-based languages, the class is modeled as an object `ArrayIterator` providing just one factory method, `new` (line 1), whose arguments are an array  $a$  and a continuation object  $r$  to which the fresh instance of the iterator is sent. The iterator itself is an object `o` that can be in one of three states, `INIT`, `SOME`, and `NONE`. States `INIT` and `SOME` have arguments  $a$  (the array being iterated) and  $n$  (the index of the current element in the array). `INIT` is a transient state used for initializing the iterator (lines 3–4): the iterator spontaneously moves into either state `SOME` or state `NONE`, depending on whether  $n$  is smaller than the length  $\#a$  of the array or not. When in state `SOME`, the iterator provides a `next` operation (lines 5–6) for reading the current element  $a[n]$

[NULL]	$\Vdash$ null	$\Rightarrow$	$\Vdash$
[DEF]	$\mathcal{D} \Vdash \mathcal{P}, \text{def } a = C \text{ in } P$	$\Rightarrow$	$\mathcal{D}, a = C \Vdash \mathcal{P}, P \quad a \notin \text{fn}(\mathcal{P})$
[COMP-1]	$\Vdash P \mid Q$	$\Rightarrow$	$\Vdash P, Q$
[COMP-2]	$\Vdash a.(M \mid N)$	$\Rightarrow$	$\Vdash a.M, a.N$
[RED]	$a = \{J_i \triangleright P_i\}_{i \in I} \Vdash a.\sigma J_k$	$\rightarrow$	$a = \{J_i \triangleright P_i\}_{i \in I} \Vdash \sigma P_k \quad k \in I$

**Table 2.** Reduction semantics of the Objective Join Calculus.

of the array and moving onto the next one. Since  $n$  might be the index of the last element of the array, the iterator transits to state INIT, which appropriately re-initializes the iterator. The iterator also provides a peek operation that can be used for querying the state of the iterator (lines 7–8). The operation does not change the state of the iterator and sends a message on the continuation  $r$  with either tag `some` or tag `none`, depending on the internal state of the iterator. ■

**Example 3.2** (sequential composition). In this example we see how to encode a sequential composition construct

$$\text{let } \tilde{u} = u.m(\tilde{v}) \text{ in } P$$

in the Objective Join Calculus. Intuitively, this construct invokes method  $m$  on object  $u$  with arguments  $\tilde{v}$ , waits for the results  $\tilde{u}$  of the invocation, and continues as  $P$ . We let

$$\begin{aligned} \text{let } \tilde{u} = u.m(\tilde{v}) \text{ in } P &\stackrel{\text{def}}{=} \\ \text{def } c = \text{WAIT}(\tilde{x}) \mid \text{reply}(\tilde{u}) \triangleright P\{\tilde{x}/\tilde{w}\} & \\ \text{in } c.\text{WAIT}(\tilde{w}) \mid u.m(\tilde{v}, c) & \end{aligned}$$

where  $c$  and  $\tilde{x}$  are fresh,  $\tilde{w} = \text{fn}(P) \setminus \tilde{u}$ , and  $P\{\tilde{x}/\tilde{w}\}$  denotes  $P$  where  $\tilde{u}$  have been replaced by  $\tilde{x}$ . The twist in this encoding is that all the free names of  $P$  except  $\tilde{u}$  are temporarily spilled into a message `WAIT` and then recovered when the callee sends the `reply` message on  $c$ . Normally, such spilling is not necessary in the encoding with continuation passing. We do it here to comply with our working assumption that classes have no free names other than “self”. ■

Using this construct we rephrase the code of Listing 1 into that of Listing 3, which also encapsulates the lock definition into the `Lock` class. The re-binding of the `lock` name on lines 5 and 6 is typical of languages with explicit continuations [18]. An actual language would provide either adequate syntactic sugar or a native synchronous method call [15]. The types in comments will be described in Section 4. ■

**Example 3.3** (dining philosophers). We now discuss an example where the same lock is shared by two concurrent processes. Listing 4 models two philosophers that compete for the same fork when hungry. The fork is created on line 7 and shared by two instances of the `Philosopher` class (line 8). Each philosopher alternates between states `THINK` and `EAT`. In addition, the `FORK` message holds a reference to the shared fork and is meant to be an invariant part of each philosopher’s state. Transitions occur non-deterministically: while in state `THINK`, the reaction on line 2 may fire; at that point,

```

1 def Lock = new(r) ▷
2   def o = FREE | acquire(r) ▷ o.BUSY | r.reply(o)
3     or   BUSY | release  ▷ o.FREE
4   in o.FREE | r.reply(o)
5 in let lock = Lock.new      (* lock : tACQUIRE *)
6 in let lock = lock.acquire (* lock : tRELEASE *)
7 in lock.release

```

**Listing 3.** Lock class definition.

```

1 def Philosopher = new(fork) ▷
2   def o = THINK | FORK(fork) ▷
3     o.FORK(fork) |
4     let f = fork.acquire in o.EAT(f)
5     or   EAT(f) ▷ o.THINK | f.release
6   in o.THINK | o.FORK(fork)
7 in let fork = Lock.new (* fork : tACQUIRE *)
8 in Philosopher.new(fork) | Philosopher.new(fork)

```

**Listing 4.** Two dining philosophers.

the philosopher restores the `FORK` message (line 3) and attempts to acquire the fork; when the fork is acquired, the philosopher transits into state `EAT` (line 4). While in state `EAT`, the philosopher holds a reference  $f$  to the acquired fork; when the reaction on line 5 fires, the fork is released and the philosopher goes back to state `THINK`. Note that this reaction consumes only part of the philosopher’s state, which also comprises the `FORK` message. ■

## 4. Syntax and semantics of types

In this section we define a type language to describe objects protocols in terms of the *valid configurations* of messages they accept. *Types*  $t, s, \dots$  are the regular trees [8] coinductively generated by the productions below:

$$t, s ::= \mathbb{0} \mid \mathbb{1} \mid m(\tilde{t}) \mid t \oplus s \mid t \otimes s \mid *t$$

The type  $m(\tilde{t})$  denotes an object that *must* be used for sending a message with tag  $m$  and arguments of type  $\tilde{t}$ ; when  $\tilde{t}$  is the empty tuple, we omit the parentheses altogether. Compound types are built using the behavioral connectives  $\oplus$ ,  $\otimes$ , and  $*$ : an object of type  $t \oplus s$  *must* be used either according to  $t$  or according to  $s$ ; an object of type  $t \otimes s$  *must* be used both according to  $t$  and also according to  $s$ ; an object of type  $*t$  *can* be used any number of times, each time

according to  $t$ . Finally, we introduce the constants  $\mathbb{0}$  and  $\mathbb{1}$ , which respectively represent the empty sum and the empty product. Intuitively,  $\mathbb{0}$  is the type of all objects and  $\mathbb{1}$  is the type of all objects without obligations. Occasionally we will also use basic types such as `int` and `real` for denoting the respective constants.

Some examples: an object of type  $m(\text{int})$  must be used for sending an  $m$  message with one argument of type `int`; an object of type  $m(\text{int}) \oplus \mathbb{1}$  can be used for sending an  $m$  message, or it can be left alone; an object of type  $m \oplus m'$  must be used for sending either an  $m$  message or an  $m'$  message, while an object of type  $m \otimes m'$  must be used for sending both an  $m$  message and an  $m'$  message; finally, an object of type  $*(m \oplus m')$  can be used for sending any number of  $m$  and  $m'$  messages. There is no legal way to use an object of type  $\mathbb{0}$ .

We do not devise an explicit syntax for recursive types. We work instead with (possibly infinite) regular terms directly. Recall that regular terms can always be finitely represented either as systems of equations or using the well-known  $\mu$  notation; [8] is the standard reference for the theory of regular trees. For example, the type satisfying the equation  $t = \mathbb{1} \oplus m(t)$  denotes an object that can be used for sending an  $m$ -tagged message with an argument which is itself an object with type  $t$ . We require every infinite branch of a type to go through infinitely many message type constructors. This condition (a strengthened contractiveness) excludes meaningless terms such as  $t = t \oplus t$  or  $t = *t$  and provides us with an induction principle on the structure of types that we will use in Definition 4.1 below.

We reserve some notation for useful families of types: we use  $M$  to range over *message types*  $m(\tilde{t})$  and  $T, S$  to range over *molecule types*, namely types of the form  $\bigotimes_{i \in I} M_i$ ; we identify molecule types modulo associativity and commutativity of  $\otimes$  and product with  $\mathbb{1}$ ; if  $T = \bigotimes_{i \in I} m_i(\tilde{t}_i)$ , we write  $\bar{T}$  for its *signature*, namely the set  $\{m_i\}_{i \in I}$ .

The following definition formalizes the idea that types describe the valid configurations of messages that can be sent to objects. Whenever  $X$  and  $Y$  are sets of molecule types, we let  $XY \stackrel{\text{def}}{=} \{T \otimes S \mid T \in X \wedge S \in Y\}$  and we write  $X^n$  for the  $n$ -th power of  $X$  for  $n \in \mathbb{N}$ , where  $X^0 = \{\mathbb{1}\}$ .

**Definition 4.1** (valid configuration). The *interpretation* of a type  $t$ , denoted by  $\llbracket t \rrbracket$ , is the set of molecule types inductively defined by the following equations:

$$\begin{array}{lll} \llbracket \mathbb{0} \rrbracket \stackrel{\text{def}}{=} \emptyset & \llbracket t \oplus s \rrbracket \stackrel{\text{def}}{=} \llbracket t \rrbracket \cup \llbracket s \rrbracket & \llbracket M \rrbracket \stackrel{\text{def}}{=} \{M\} \\ \llbracket \mathbb{1} \rrbracket \stackrel{\text{def}}{=} \{\mathbb{1}\} & \llbracket t \otimes s \rrbracket \stackrel{\text{def}}{=} \llbracket t \rrbracket \llbracket s \rrbracket & \llbracket *t \rrbracket \stackrel{\text{def}}{=} \bigcup_{n \in \mathbb{N}} \llbracket t \rrbracket^n \end{array}$$

We say that  $T$  is a *valid configuration* for  $t$  if  $T \in \llbracket t \rrbracket$ .

For instance,  $\llbracket m \oplus m' \rrbracket = \{m, m'\}$  and  $\llbracket m \otimes m' \rrbracket = \{m \otimes m'\}$ . Indeed, in the first case one can choose to send *either*  $m$  or  $m'$ , whereas in the second case one must send *both*. Note that  $\mathbb{0}$  has no valid configurations and that type  $*t$  has, in general, infinitely many valid configurations. For instance,  $\llbracket *m \rrbracket = \{\mathbb{1}, m, m \otimes m, m \otimes m \otimes m, \dots\}$ .

We have collected all the ingredients for defining the subtyping relation. Since types are possibly infinite terms, we must resort to a coinductive definition:

**Definition 4.2** (subtyping). We write  $\leq$  for the largest relation between types such that  $t \leq s$  and  $\bigotimes_{i \in I} m_i(\tilde{s}_i) \in \llbracket s \rrbracket$  imply  $\bigotimes_{i \in I} m_i(\tilde{t}_i) \in \llbracket t \rrbracket$  and  $\tilde{s}_i \leq \tilde{t}_i$  for every  $i \in I$ . If  $t \leq s$  holds, then we say that  $t$  is a *subtype* of  $s$  and  $s$  a *supertype* of  $t$ . We write  $t \simeq s$  if  $t \leq s$  and  $s \leq t$ .

To understand subtyping, it helps keeping in mind the usual safe substitution principle: when  $t \leq s$ , it is safe to use an object of type  $t$  where an object of type  $s$  is expected. In our setting, “using an object of type  $s$ ” means sending to the object a message configuration that is valid for  $s$ . Definition 4.2 requires each valid configuration for  $s$  to also be a valid configuration for  $t$ , modulo contravariant subtyping of argument types. More specifically, whenever  $S \in \llbracket s \rrbracket$ , there exists some  $T \in \llbracket t \rrbracket$  with the same signature as  $S$  such that the arguments of corresponding messages in  $T$  and  $S$  are related contravariantly. For instance, if  $s = m(\text{int})$ , then using an object of type  $s$  means sending to the object one message of the form  $m(n)$ , where  $n$  is an integer number. Then, assuming `int`  $\leq$  `real`, it is safe to replace such object with another one of type  $t = m(\text{real})$ : the message  $m(n)$  sent to the former object will be understood without problems also by the latter object, as any integer number is also a real number. Therefore,  $m(\text{real}) \leq m(\text{int})$ .

We wish to reassure the reader bewildered by Definition 4.2 that  $\leq$  shares most traits with conventional subtyping relations for object-oriented languages (see Example 4.5). In particular, we have  $m \oplus m' \leq m$ , namely an object to which it is possible to send either an  $m$  message or a  $m'$  message can be safely used in place of an object that accepts only the former kind of messages. On the contrary,  $m \otimes m'$  and  $m$  are *not* related: the former object must be used for sending both  $m$  and  $m'$ , hence sending only  $m$  is an illegal way of using it. Another notable relation is  $m(t) \oplus m(s) \leq m(t \oplus s)$ .

The interested reader can verify a number of additional useful properties: that  $\mathbb{0}$  and  $\mathbb{1}$  are indeed the units of  $\oplus$  and  $\otimes$ ; that  $\mathbb{0}$  is absorbing for  $\otimes$ ; that  $\oplus$  distributes over  $\otimes$ . We capture all these properties by the following proposition.

**Proposition 4.3.** *The following properties hold:*

1.  $\leq$  is a pre-order and a pre-congruence;
2. the language of types taken modulo the  $\simeq$  equivalence is a commutative Kleene algebra [7].

We give a useful taxonomy of types: *linear* types denote objects that *must* be used; *non-linear* types denote objects without obligations; *usable* types denote objects that *can* be used, in the sense that there is a valid way of using them.

**Definition 4.4** (type classification). We say that  $t$  is *non linear*, notation  $\text{nl}(t)$ , if  $t \leq \mathbb{1}$ ; that  $t$  is *linear*, notation  $\text{lin}(t)$ , if  $t \not\leq \mathbb{1}$ ; that  $t$  is *usable*, notation  $\text{usable}(t)$ , if  $t \not\approx \mathbb{0}$ .

If  $t \leq \mathbb{1}$ , then  $\mathbb{1} \in \llbracket t \rrbracket$  namely it is allowed not to send any message to an object of type  $t$ . If  $t \simeq \mathbb{0}$ , then  $t$  is linear but not usable, hence it denotes *absurd* objects that must be used, but at the same time such that there is no valid way of using them.

**Example 4.5** (standard class type). The class of a conventional object-oriented language can be described as the type  $\otimes_{i \in I} *m_i(\tilde{t}_i)$ , saying that the objects of this class can be used for unlimited invocations of all of the available methods, in whatever order. Our subtyping relation is consistent with that typically adopted in such languages, since  $\otimes_{i \in I} *m_i(\tilde{t}_i) \leq \otimes_{j \in J} *m_j(\tilde{s}_j)$  if and only if  $I \supseteq J$  and  $\tilde{t}_j \geq \tilde{s}_j$  for all  $j \in J$  (the subclass has more methods, with arguments of larger type). ■

**Example 4.6** (lock interfaces). We illustrate the typing of the lock object used in Listings 1 and 3. Observe that the type  $t_{lock}$ , discussed in Section 2, describes both states and operations and is a valid type for the lock object as a whole. Correspondingly,  $t_{lock}$  can be correctly assigned to the binding occurrence of `o` on line 2 in Listing 3 according to the type system we will define in Section 5. Lock users are solely concerned with the public interfaces of the lock, which only refer to the `acquire` and `release` methods. We define:

$$\begin{aligned} t_{ACQUIRE} &\stackrel{\text{def}}{=} *acquire(\text{reply}(t_{RELEASE})) \\ t_{RELEASE} &\stackrel{\text{def}}{=} \text{release} \end{aligned}$$

respectively for the interface of unacquired and acquired locks. Observe that  $t_{ACQUIRE}$  is non linear, indicating no obligations on unacquired locks (they can be used any number of times) whereas  $t_{RELEASE}$  is linear, indicating that acquired locks must (eventually) be released. These interfaces can be “derived” (quite literally) by removing the state types from  $t_{lock}$ ; we will make this relation precise in Section 5.

The fact that (unacquired) locks can be shared without constraints is a consequence of the relation

$$t_{ACQUIRE} \simeq t_{ACQUIRE} \otimes t_{ACQUIRE}$$

stating an expected property of the exponential: “duplicating” a fork has no effect on its type. This relation is precisely the one needed for typing the code in Listing 4, where one fork of type  $t_{ACQUIRE}$  is created (line 7) and then shared by two philosophers (line 8). ■

**Example 4.7** (iterator interfaces). Let consider the array iterator defined in Listing 2. We postpone the description of the whole type of the iterator object until Section 5, and we discuss here just the public interfaces exposed by the object in the different states, with the help of the transition diagram in Figure 1. When in state NONE, the iterator has reached the end of the array and there is only one method available, `peek`, which replies with a `none` message containing the iterator unchanged. Therefore, the public interface of the

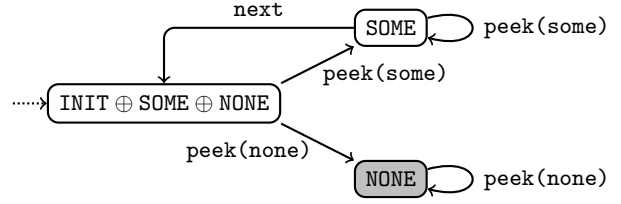

**Figure 1.** Transition diagram of the iterator.

iterator in state NONE is the type satisfying the equation

$$t_{NONE} = \text{peek}(\text{none}(t_{NONE})) \oplus \mathbb{1}$$

The  $\mathbb{1}$  term makes  $t_{NONE}$  non linear, allowing the disposal of the iterator when in state NONE. Without it, linearity would force us to keep using the iterator even at the end of the iteration. This is depicted in Figure 1 with a shaded box.

The interface of the iterator in state SOME must give access to both the `next` and `peek` operations. A tentative type for the iterator in this state is the one satisfying the equation

$$t_{SOME} = \text{peek}(\text{some}(t_{SOME})) \oplus \text{next}(\text{reply}(\text{int}, t_?))$$

where `peek` replies with a `some` message containing the iterator unchanged, whereas `next` returns the current element of the array being scanned (of type `int`) and the iterator in an updated state. Inspection of Listing 2 reveals that, after a `next` operation, the iterator temporarily moves into state INIT and then eventually reaches either state SOME or state NONE. Therefore, the type  $t_?$  exposing the public interface in this unresolved state is obtained as the “intersection” of the interfaces of the two possible states. More precisely,  $t_?$  must be a supertype of both  $t_{NONE}$  and  $t_{SOME}$ . It is not difficult to verify that the  $\leq$ -least upper bound of  $t_{NONE}$  and  $t_{SOME}$  is

$$t_{BOTH} = \text{peek}(\text{some}(t_{SOME})) \oplus \text{none}(t_{NONE})$$

showing that, when the state of the iterator is uncertain, only `peek` is allowed. Observe also that `peek` has different types, depending on whether the state of the iterator is known or not: when the state is known, the type of `peek` is more precise (only `some` or only `none` is sent); when the state is unknown, the type of `peek` is less precise (either `some` or `none` is sent). Subtyping tunes the precision of the types of objects, according to the knowledge of their state. ■

## 5. Type system

**Type environments.** We use type environments for tracking the type of the objects used by processes. A *type environment*  $\Gamma$  is a finite mapping from names to types, written  $u_1 : t_1, \dots, u_n : t_n$  or  $\tilde{u} : \tilde{t}$  or  $\{u_i : t_i\}_{i \in I}$  as convenient. We write  $\text{dom}(\Gamma)$  for the domain of  $\Gamma$  and  $\Gamma_1, \Gamma_2$  for the union of  $\Gamma_1$  and  $\Gamma_2$ , when  $\text{dom}(\Gamma_1) \cap \text{dom}(\Gamma_2) = \emptyset$ .

Since each object may be used in different parts of a program according to different interfaces, we need a more flexible environment combination operator than (disjoint) union.



The environment in which a process is typed describes how the process uses the objects for which there is a type assignment in the environment. If the *same* object is simultaneously used by two (or more) processes, its type will be the combination (*i.e.*, the product) of all the types it has in the environments used for typing the processes. For example, if some object  $u$  is shared by two distinct processes  $P$  and  $Q$  running in parallel,  $P$  uses  $u$  according to  $t$  and  $Q$  uses  $u$  according to  $s$ , then the parallel composition of  $P$  and  $Q$  uses  $u$  according to  $t \otimes s$ . If, on the other hand, the object  $u$  is used by only one of the two processes, say  $P$ , according to  $t$ , then it is used according to  $t$  also by the parallel composition of  $P$  and  $Q$ . Formally, we define an operation  $\otimes$  for combining type environments, thus:

**Definition 5.1** (environment combination). The *combination* of  $\Gamma_1$  and  $\Gamma_2$  is the type environment  $\Gamma_1 \otimes \Gamma_2$  such that  $\text{dom}(\Gamma_1 \otimes \Gamma_2) = \text{dom}(\Gamma_1) \cup \text{dom}(\Gamma_2)$  defined by:

$$(\Gamma_1 \otimes \Gamma_2)(u) \stackrel{\text{def}}{=} \begin{cases} \Gamma_1(u) & \text{if } u \in \text{dom}(\Gamma_1) \setminus \text{dom}(\Gamma_2) \\ \Gamma_2(u) & \text{if } u \in \text{dom}(\Gamma_2) \setminus \text{dom}(\Gamma_1) \\ \Gamma_1(u) \otimes \Gamma_2(u) & \text{otherwise} \end{cases}$$

Many substructural type systems define analogous operators for combining type environments. See for example  $+$  in [22] or  $\uplus$  in [24].

It is also convenient to extend the subtyping relation to type environments, to ease the application of subsumption. Intuitively, the relation  $t \leq s$  indicates that an object of type  $t$  “has more features” than an object of type  $s$ . Similarly, we wish to extend  $\leq$  to environments so that  $\Gamma \leq \Delta$  indicates that the environment  $\Gamma$  has more resources with possibly more features than  $\Delta$ . We must be careful not to introduce in  $\Gamma$  linear resources that are not in  $\Delta$ , for this would allow processes to ignore objects for which they have obligations. Technically, we allow weakening for non-linear objects only. The extension of  $\leq$  to type environments is formalized thus:

**Definition 5.2** (environment subtyping). We write  $\Gamma \leq \Delta$  if:

1.  $\text{dom}(\Delta) \subseteq \text{dom}(\Gamma)$ , and
2.  $\Gamma(u) \leq \Delta(u)$  for every  $u \in \text{dom}(\Delta)$ , and
3.  $\text{nl}(\Gamma(u))$  for every  $u \in \text{dom}(\Gamma) \setminus \text{dom}(\Delta)$ .

Using environment subtyping, we can express the fact that an environment  $\Gamma$  only contains non-linear resources by checking whether  $\Gamma \leq \emptyset$  holds. In this case, we write  $\text{nl}(\Gamma)$ .

With these notions, we can start commenting on the rules of the type system, shown in Table 3. The rules allow deriving various judgments, for processes, molecules, patterns, classes, and solutions.

Rule [T-NULL] states that the idle process is well typed only in an empty environment. Since the idle process does nothing, the absence of linear objects in the environment makes sure that no linear object is left unused. On the other hand, non-linear objects can always be discharged using subsumption [T-SUB], which will be described shortly.

### Typing rules for processes

$$\boxed{\Gamma \vdash P}$$

$$\begin{array}{c} \text{[T-NULL]} \\ \frac{}{\emptyset \vdash \text{null}} \end{array} \quad \begin{array}{c} \text{[T-SEND]} \\ \frac{\Gamma \vdash M :: T}{\Gamma \otimes u : T \vdash u.M} \end{array} \quad \begin{array}{c} \text{[T-PAR]} \\ \frac{\Gamma_i \vdash P_i \ (i=1,2)}{\Gamma_1 \otimes \Gamma_2 \vdash P_1 \mid P_2} \end{array}$$

$$\begin{array}{c} \text{[T-OBJECT]} \\ \frac{a : t \vdash C \quad \Gamma, a : t \vdash P}{\Gamma \vdash \text{def } a = C \text{ in } P} \end{array} \quad \begin{array}{c} \text{[T-SUB]} \\ \frac{\Delta \vdash P}{\Gamma \vdash P} \quad \Gamma \leq \Delta \end{array}$$

### Typing rules for molecules

$$\boxed{\Gamma \vdash M :: T}$$

$$\begin{array}{c} \text{[T-MSG-M]} \\ \frac{\text{usable}(\tilde{t}) \quad \tilde{u} = u_1, \dots, u_n}{\otimes_{i=1..n} u_i : t_i \vdash \text{m}(\tilde{u}) :: \text{m}(\tilde{t})} \quad \tilde{t} = t_1, \dots, t_n \end{array}$$

$$\begin{array}{c} \text{[T-COMP-M]} \\ \frac{\Gamma_i \vdash M_i :: T_i \ (i=1,2)}{\Gamma_1 \otimes \Gamma_2 \vdash M_1 \mid M_2 :: T_1 \otimes T_2} \end{array}$$

### Typing rules for patterns

$$\boxed{\Gamma \vdash J :: T}$$

$$\begin{array}{c} \text{[T-MSG-P]} \\ \frac{\text{usable}(\tilde{t})}{\tilde{x} : \tilde{t} \vdash \text{m}(\tilde{x}) :: \text{m}(\tilde{t})} \end{array} \quad \begin{array}{c} \text{[T-COMP-P]} \\ \frac{\Gamma_i \vdash J_i :: T_i \ (i=1,2)}{\Gamma_1, \Gamma_2 \vdash J_1 \mid J_2 :: T_1 \otimes T_2} \end{array}$$

### Typing rules for classes

$$\boxed{u : t \vdash C}$$

$$\begin{array}{c} \text{[T-REACTION]} \\ \frac{\Gamma \vdash J :: T \quad \Gamma, a : s \vdash P}{a : t \vdash J \triangleright P} \quad \begin{array}{l} t \downarrow T \\ t \leq t[T] \otimes s \end{array} \end{array}$$

$$\begin{array}{c} \text{[T-CLASS]} \\ \frac{a : t \vdash C_i \ (i=1,2)}{a : t \vdash C_1 \text{ or } C_2} \end{array}$$

### Typing rules for solutions

$$\boxed{\vdash \mathcal{D} \Vdash \mathcal{P}}$$

$$\begin{array}{c} \text{[T-DEFINITIONS]} \\ \frac{a_i : t_i \vdash C_i \ (i \in I)}{\{a_i : t_i\}_{i \in I} \vdash \{a_i = C_i\}_{i \in I}} \end{array} \quad \begin{array}{c} \text{[T-PROCESSES]} \\ \frac{\Gamma_i \vdash P_i \ (i \in I)}{\otimes_{i \in I} \Gamma_i \vdash \{P_i\}_{i \in I}} \end{array}$$

$$\begin{array}{c} \text{[T-SOLUTION]} \\ \frac{\Gamma \vdash \mathcal{D} \quad \Delta \vdash \mathcal{P}}{\vdash \mathcal{D} \Vdash \mathcal{P}} \quad \Gamma \leq \Delta \end{array}$$

**Table 3.** Typing rules.

Rule [T-SEND] types message sending  $u.M$ , where  $u$  is an object and  $M$  a molecule of messages. This process is well typed if the type of the object coincides with that of the molecule, which as we will see is just the  $\otimes$ -composition of the types of the messages in it. Note the use of  $\otimes$  in the type environment allowing  $u$  to possibly occur in  $M$  as the argument of some message.

Rule [T-PAR] types parallel compositions  $P_1 \mid P_2$ . The rule combines the type environments used for typing  $P_1$  and  $P_2$  to properly keep track of the overall use of the objects shared by the two processes.

Rule [T-OBJECT] types object definitions  $\text{def } a = C \text{ in } P$ . A type  $t$  is guessed for the object  $a$  and checked to be appropriate for the class  $C$  (“appropriateness” will be discussed along with the typing rules for classes) and assigned to  $a$  also for typing  $P$ . Note that the class  $C$  is checked in an environment that contains only  $a$  (that is “self”). That is, the type system forces classes to contain no free names other than the reference to self. In principle this is not a restriction, as we have seen in Example 3.2, although in practice it is desirable to allow for more flexibility. We have made this choice to keep the type system as simple as possible. In fact, the type system would remain sound if we allowed  $C$  to access non-linear objects. Allowing  $C$  to access linear objects is a much more delicate business that requires non-trivial reasoning on the sequence of firings of the rules in  $C$ ; we leave this as a future extension.

Rule [T-SUB] is the subsumption rule, allowing us to enrich the type environment of a process according to Definition 5.2. Intuitively, if  $P$  is well typed using the objects described by  $\Delta$ , then it certainly is well typed in an environment  $\Gamma \leq \Delta$  where the same objects have more features than those actually used by  $P$ . This rule is also useful for rewriting the types in the environment as well as for weakening  $\Delta$  with non-linear objects.

The typing rules for molecules derive judgments of the form  $\Gamma \vdash M :: T$ . The environment  $\Gamma$  describes the type of the arguments *sent* along the messages in  $M$ . The only remarkable feature is the side condition  $\text{usable}(\tilde{t})$  in [T-MSG-M], which requires the arguments of a message to be usable or, at least, discardable. This condition is essential for the soundness of the type system (see Example 6.5).

The typing rules for patterns have the form  $\Gamma \vdash J :: T$  and are similar to those for molecules. Recall that patterns occur on the left hand side of reaction rules. In this case, the environment  $\Gamma$  describes the type of the arguments *received* when the pattern matches a molecule in the soup. There is a technical difference between [T-COMP-M] and [T-COMP-P]: the former uses the operator  $\otimes$  for combining type environments, as it may happen that the same object is sent as argument in different messages; the latter takes the union of the environments, which are known to have disjoint domains because of the linearity restriction we have imposed on patterns. Also recall that joined patterns must have disjoint signatures.

Before looking at the typing rules for classes, let us get rid of those for solutions  $\mathcal{D} \Vdash \mathcal{P}$ , which are essentially unremarkable. Each object definition in  $\mathcal{D}$  is typed as in rule [T-OBJECT] and the processes in the multiset  $\mathcal{P}$  are typed as if they were all composed in parallel. The two typings are kept consistent by the fact that [T-SOLUTION] uses *related* environments  $\Gamma$  and  $\Delta$  for both  $\mathcal{D}$  and  $\mathcal{P}$ . The reason why  $\Delta$  is not exactly  $\Gamma$  is purely technical and accounts for the formal mismatch between processes composed in parallel and processes in a multiset (details are in Appendix A).

The type system described so far is rather ordinary: the typing rules track the usage of objects, most of the heavy lifting is silently done by subtyping and the  $\otimes$  operator. The heart of the type system is [T-REACTION], which verifies that a reaction rule  $J \triangleright P$  is appropriate for an object  $a$  of type  $t$ . The rule determines the type  $T$  and bindings  $\Gamma$  of the pattern  $J$  and checks that the body  $P$  of the rule is well typed in the environment  $\Gamma, a : s$ . Having  $a$  in the environment grants  $P$  access to “self”. Now, we have to understand which relations should hold among  $t$ ,  $T$ , and  $s$  in order for the reaction rule to be safe. In this context “safe” means that:

- (1)  $T$  describes correctly the type of the received arguments. This is not obvious, because the same tag can be used in messages with arguments of different types (see for example `peek` in Example 3.1) while reduction picks messages solely looking at their tag (Table 2).
- (2) By using  $a$  according to  $s$ ,  $P$  restores the state of  $a$  into one of its valid configurations, described by  $t$ . Again this is not obvious, because the only knowledge that  $P$  has regarding the state of  $a$  comes from the matching of  $J$ , which in general is a fraction of all the messages targeted to  $a$  at the time of the reaction.

Condition (1) is characterized by a predicate  $t \downarrow T$  saying when a given molecule type  $T$  is not ambiguous in  $t$ :

**Definition 5.3** (clear pattern). We say that  $T$  is *clear* in  $t$ , notation  $t \downarrow T$ , if  $\{S \mid S \otimes R \in \llbracket t \rrbracket \wedge \bar{S} = \bar{T}\} = \{T\}$ .

In words,  $t \downarrow T$  holds if for each valid configuration  $S \otimes R$  of  $t$  that includes a molecule type  $S$  sharing the same signature as  $T$ , the molecule type is exactly  $T$ . In addition, there must be a valid configuration of  $t$  that includes  $T$ . This means that, whenever  $t \downarrow T$  holds,  $t$  is usable.

For example, take  $t \stackrel{\text{def}}{=} (A \otimes \text{m}(\text{int})) \oplus (B \otimes \text{m}(\text{real}))$  and observe that the argument of message  $\text{m}$  has different types depending on whether the state of the object is  $A$  or  $B$ . Then, neither  $t \downarrow \text{m}(\text{int})$  nor  $t \downarrow \text{m}(\text{real})$  holds, for matching an  $\text{m}$ -tagged message does not provide enough information for deducing the type of its argument. However, both  $t \downarrow A \otimes \text{m}(\text{int})$  and  $t \downarrow B \otimes \text{m}(\text{real})$  do hold, since in these cases the signature of the matched molecule disambiguates the type of  $\text{m}$ ’s argument.

*Remark 5.4.* Suppose  $t = (\text{m}(\text{foo}) \otimes \text{m}(\text{bar})) \oplus \mathbb{1}$  and that the reaction  $J \triangleright x.\text{foo} \mid y.\text{bar}$  where  $J = \text{m}(x) \mid \text{m}(y)$  is

allowed, despite  $m$  occurs twice in  $J$ . We have

$$x : \text{foo}, y : \text{bar} \vdash J :: T$$

where  $T = m(\text{foo}) \otimes m(\text{bar})$ . Now  $t \downarrow T$  does hold, because  $t$  has only one valid configuration with the same signature as  $T$ . However, there is no guarantee that, once  $J$  matches a molecule,  $x$  is actually bound to the object of type  $\text{foo}$  and  $y$  is actually bound to the object of type  $\text{bar}$ , and not vice versa. For this reason, pattern linearity is a key restriction in our type system, where messages with the same tag can have arguments with different types. ■

To find guidance for verifying condition (2) it helps recalling the chemical interpretation of the Objective Join Calculus: the effect of a reaction  $J \triangleright P$  where  $J$  has type  $T$  and  $P$  uses the object according to  $s$  is to *consume* a molecule of messages of type  $T$  and to *produce* molecules according to type  $s$ . The reaction is safe if the overall balance between what is consumed and what is produced preserves the object's configuration as one that is described by its type  $t$ . Formally, this is expressed by the side condition  $t \leq t[T] \otimes s$ , where the type  $t[T]$  represents the “residual” of  $t$  after a molecule with type  $T$  (the pattern of the reaction rule) has been removed; such residual is combined (in the sense of  $\otimes$ ) with  $s$ , which is what  $P$  sends to the object; the resulting type  $t[T] \otimes s$  is compatible with the object's type  $t$  if it is a supertype of  $t$ . The type residual operator is defined thus:

**Definition 5.5** (type residual). The *residual* of  $t$  with respect to  $M$ , written  $t[M]$ , is inductively defined thus:

$$\begin{aligned} \emptyset[M] &= \mathbb{1}[M] = \emptyset \\ m(\dot{t})[m'(\dot{s})] &= \emptyset && \text{if } m \neq m' \\ m(\dot{t})[m(\dot{s})] &= \mathbb{1} \\ (t \oplus s)[M] &= t[M] \oplus s[M] \\ (t \otimes s)[M] &= (t[M] \otimes s) \oplus (t \otimes s[M]) \\ (*t)[M] &= t[M] \otimes *t \end{aligned}$$

We extend the residual to molecule types in the obvious way, that is  $t[\mathbb{1}] = t$  and  $t[M \otimes T] = t[M][T]$ .

Note that the type residual operator (Definition 5.5) is nothing but *Brzozowski derivative* [6, 7] adapted to a commutative Kleene algebra over message types.

To better illustrate the side condition, we work out some examples in which we consider different objects  $a$  of type  $t$  and we write  $T \triangleright s$  for denoting a reaction  $J \triangleright P$  where  $J$  has type  $T$  and  $P$  is typed in an environment that includes  $a : s$ . We will say that  $T \triangleright s$  is valid or invalid depending on whether the condition holds or not.

- If  $t \stackrel{\text{def}}{=} A \oplus (B \otimes m)$ , then  $A \triangleright B \otimes m$  and  $B \otimes m \triangleright A$  are valid but  $B \triangleright A$  is not. For example, we have  $t[B] = m$  and  $t \not\leq m \otimes A$ . When in state  $B$ , there is also a message  $m$  that is forbidden in state  $A$ .
- If  $t \stackrel{\text{def}}{=} (A \otimes m) \oplus (B \otimes (\mathbb{1} \oplus m))$ , then  $A \triangleright B$  is valid but  $B \triangleright A$  is not. We have  $t[B] = \mathbb{1} \oplus m$  and  $t \not\leq (\mathbb{1} \oplus m) \otimes A$ .

In general, the transition from a state in which a message is linear ( $m$ ) to another where the message is not linear ( $\mathbb{1} \oplus m$ ) cannot be reversed, because the object may have been discarded or aliased.

- If  $t \stackrel{\text{def}}{=} A \oplus (B \otimes *foo) \oplus (C \otimes *foo \otimes *bar)$ , then  $A \triangleright B$  and  $B \triangleright C$  are valid, but neither  $B \triangleright A$  nor  $C \triangleright B$  is. It is unsafe for the object to move from state  $C$  to state  $B$  because there could be residual  $\text{bar}$  messages not allowed in state  $B$ . In general, non-linear messages such as  $\text{foo}$  and  $\text{bar}$  can only accumulate monotonically across state transitions.
- If  $t \stackrel{\text{def}}{=} (A \otimes m(\text{int})) \oplus (B \otimes m(\text{real}))$ , then  $A \triangleright B$  is valid, but  $B \triangleright A$  is not. Indeed  $t[B] = m(\text{real})$  and  $t \not\leq m(\text{real}) \otimes A$ . The transition  $A \triangleright B$  is safe because the  $\text{int}$  argument of message  $m$  in state  $A$  can be subsumed to  $\text{real}$  in state  $B$ , but not vice versa.

**Example 5.6** (lock). We illustrate the type system at work showing that the two reactions of the lock (lines 2–3 in Listing 3) are well typed using  $t_{\text{lock}}$ , the types  $t_{\text{ACQUIRE}}$  and  $t_{\text{RELEASE}}$  of Example 4.6, and also  $t_{\text{REP}} \stackrel{\text{def}}{=} \text{reply}(t_{\text{RELEASE}})$ . Consider the first reaction; for its pattern we derive

$$r : t_{\text{REP}} \vdash \text{FREE} \mid \text{acquire}(r) :: T$$

where  $T \stackrel{\text{def}}{=} \text{FREE} \otimes \text{acquire}(t_{\text{REP}})$ . Let  $s \stackrel{\text{def}}{=} \text{BUSY} \otimes t_{\text{RELEASE}}$ , then for the body of the reaction we derive

$$\frac{\frac{}{o : t_{\text{RELEASE}} \vdash \text{reply}(o) :: t_{\text{REP}}}}{o : \text{BUSY} \vdash o.\text{BUSY}} \quad r : t_{\text{REP}}, o : t_{\text{RELEASE}} \vdash r.\text{reply}(o)}{r : t_{\text{REP}}, o : s \vdash o.\text{BUSY} \mid r.\text{reply}(o)}$$

Now  $t_{\text{lock}} \downarrow T$  holds and furthermore

$$t_{\text{lock}} \leq t_{\text{lock}}[T] \otimes s = t_{\text{ACQUIRE}} \otimes \text{BUSY} \otimes t_{\text{RELEASE}}$$

hence the side conditions of [T-REACTION] are satisfied. For the pattern in the second reaction we derive

$$\vdash \text{BUSY} \mid \text{release} :: \text{BUSY} \otimes \text{release}$$

and it is easy to see that the body of the reaction is also well typed. Now, we have  $t_{\text{lock}} \downarrow \text{BUSY} \otimes \text{release}$  and

$$t_{\text{lock}} \leq t_{\text{lock}}[\text{BUSY} \otimes \text{release}] \otimes \text{FREE} \simeq t_{\text{ACQUIRE}} \otimes \text{FREE}$$

so the side conditions of [T-REACTION] are again satisfied, this time taking  $s \stackrel{\text{def}}{=} \text{FREE}$ . ■

**Example 5.7** (iterator). We conclude the typing of the array iterator in Example 3.1 (Listing 2). By composing the public interfaces defined in Example 4.7, we can define the type of the iterator object  $o$  as follows:

$$\begin{aligned} t_{\text{iter}} &\stackrel{\text{def}}{=} (\text{INIT}(\text{int} [], \text{int}) \otimes t_{\text{BOTH}}) \\ &\oplus (\text{SOME}(\text{int} [], \text{int}) \otimes t_{\text{SOME}}) \\ &\oplus (\text{NONE} \otimes t_{\text{NONE}}) \end{aligned}$$

```

1 def Channel = new(c) ▷
2   def o =
3     LE    | lsend(v,c) ▷ o.LF(v) | c.reply(o)
4   or LF(v) | rrecv(c) ▷ o.LE    | c.reply(v,o)
5   or RE    | rsend(v,c) ▷ o.RF(v) | c.reply(o)
6   or RF(v) | lrecv(c) ▷ o.RE    | c.reply(v,o)
7   in o.LE | o.RE | c.reply(o)
8 in ...

```

**Listing 5.** Full-duplex channel.

Notice that  $t_{iter}$  is obtained as a disjunction of three types, each corresponding to a pair encoding a possible state and the public interface of the iterator in that state.

In order to check the typing of the definition of the object  $o$  in Listing 2, we have to check four reactions; we just discuss two of them and, for readability, we only consider message tags omitting argument types. The first reaction  $INIT \triangleright SOME \oplus NONE$  is valid since  $t_{iter}[INIT] = t_{BOTH}$  and

$$\begin{aligned}
t_{iter} &\leq (SOME \oplus NONE) \otimes t_{BOTH} \\
&\simeq (SOME \otimes t_{BOTH}) \oplus (NONE \otimes t_{BOTH})
\end{aligned}$$

because  $t_{SOME} \leq t_{BOTH}$  and  $t_{NONE} \leq t_{BOTH}$  as we have argued in Example 4.7. The reaction  $SOME \otimes next \triangleright INIT \otimes t_{BOTH}$  is also valid since  $t_{iter}[SOME \otimes next] = \mathbb{1}$  and now

$$t_{iter} \leq \mathbb{1} \otimes INIT \otimes t_{BOTH} \simeq INIT \otimes t_{BOTH}$$

Observe that the code in Listing 2 does not contain any reaction involving both the state  $INIT$  and the operation  $peek$ , since the iterator in state  $INIT$  eventually moves into either state  $SOME$  or  $NONE$ ; nevertheless  $t_{iter}$  exposes the interface  $t_{BOTH}$  while in state  $INIT$ , instead of the empty interface. This is because, in lines 6 and 9, a reference  $o$  to the iterator is returned to the caller while the iterator is moving to state  $INIT$ . Such reference could be used by a quick caller to send a  $peek$  message to the iterator while the iterator is still in the transient state  $INIT$ , and this requires  $INIT \otimes peek$  to be a valid configuration of  $t_{iter}$ .

It is possible to make sure that the reference  $o$  returns to the caller only once the iterator has moved away from state  $INIT$ , by reshaping  $INIT$  into a synchronous operation. ■

**Example 5.8** (full-duplex channel). Listing 5 shows the modeling of a bidirectional, full-duplex channel for connecting two peer processes, called “left” and “right” and identified by a letter  $p \in \{l, r\}$ . The channel provides two pairs of operations  $p\text{send}$  and  $p\text{recv}$  used by peer  $p$  for sending and receiving messages. The state of the channel is modeled by two 1-place buffers, one for each peer. For the left peer,  $LE$  represents the Empty buffer and  $LF(v)$  the Full buffer with a value  $v$ . Tags  $RE$  and  $RF$  are used for representing the buffer of the right peer in a similar way. Observe that each buffer is either empty or full, but the two buffers coexist and can change state independently. This means that  $LE$  and  $LF$  are

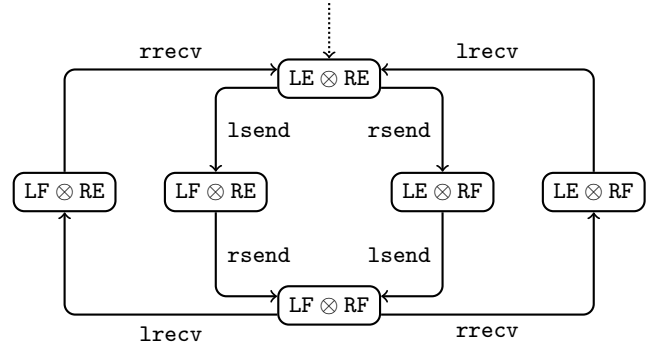

**Figure 2.** Transition diagram of the full-duplex channel.

*or-states*, and so are  $RE$  and  $RF$ : on the contrary,  $Lx$  and  $Ry$  are *and-states*. This will be reflected in the type of the channel, where different states of the same buffer are combined by  $\oplus$ , whereas states of different buffers are combined by  $\otimes$ .

We want to enforce a usage protocol of the full-duplex channel such that each peer  $p$  alternates send and receive operations. In this way, the  $p\text{send}$  of peer  $p$  fills the corresponding buffer and enables the  $\bar{p}\text{recv}$  of the other peer  $\bar{p}$ , but only after  $\bar{p}$  has sent its own message. Figure 2 depicts the transition diagram of the full-duplex channel used according to this protocol. The interface of the channel from the viewpoint of  $p$  is described by the type  $t_{ps}$  defined by

$$\begin{aligned}
t_{ps} &= p\text{send}(\text{int}, \text{reply}(t_{pr})) \\
t_{pr} &= p\text{recv}(\text{reply}(\text{int}, t_{ps}))
\end{aligned}$$

The types of the interfaces are combined with state message types to form the type of the channel as follows

$$\begin{aligned}
t_{chan} \stackrel{\text{def}}{=} & (LE \otimes RE \otimes t_{ls} \otimes t_{rs}) \oplus (LF \otimes RF \otimes t_{lr} \otimes t_{rr}) \\
& \oplus (LF \otimes RE \otimes t_{lr} \otimes t_{rs}) \oplus (LE \otimes RF \otimes t_{ls} \otimes t_{rr}) \\
& \oplus (LF \otimes RE \otimes t_{ls} \otimes t_{rr}) \oplus (LE \otimes RF \otimes t_{lr} \otimes t_{rs})
\end{aligned}$$

where we have elided the type of values in the buffers.

Inspection of  $t_{chan}$  reveals that the reference  $o$  returned on line 7 has type  $t_{ls} \otimes t_{rs}$ , that is the composition of the two public interfaces of the channel, each corresponding to one of the peers. Therefore, the *same* reference to the channel can be used by two parallel processes, according to these two types, as illustrated by the code snippet below:

```

let c = Channel.new in      (* c : tls ⊗ trs *)
{ let c = c.lsend(1) in    (* c : tlr *)
  let c = c.lrecv in ...  (* c : tls *)
| let c = c.rsend(2) in   (* c : trr *)
  let c = c.rrecv in ... } (* c : trs *)

```

The internal state of the full-duplex channel is the *combination* of distinct messages  $Lx$  and  $Ry$  that are consumed and produced *concurrently* by the users of the channel. In particular, each reaction rule in Listing 5 changes only *part* of the channel’s state, leaving the rest unchanged. The last

side condition of rule  $[\text{T-REACTION}]$  verifies that such partial change maintains the channel's overall state in one of the configurations described by  $t_{chan}$ . The interested reader can verify that each reaction rule is indeed well typed with respect to  $t_{chan}$ .

As a final consideration, the fact that  $t_{chan}$  and the diagram in Figure 2 list 6 configurations (instead of the 4 corresponding to all possible combinations of  $Lx$  and  $Ry$ ) suggests that the interface of the channel depends not only on its *current state* (encoded as a pair  $Lx \otimes Ry$ ) but also on its *past history*. For instance, in the two states identified by the combination of messages  $LF \otimes RE$ , the peer  $l$  has produced its own message while the buffer of peer  $r$  is empty. But this can be either because  $r$  has not produced its own message yet, or because  $r$  has indeed produced the message, but peer  $l$  has already received it. ■

## 6. Properties of well-typed processes

In this section we prove a few properties enjoyed by well-typed processes. To begin with, we state a completely standard, yet fundamental result showing that typing is preserved under heating, cooling, and reductions.

**Theorem 6.1** (subject reduction). *If  $\vdash \mathcal{D} \Vdash \mathcal{P}$  and*

$$\mathcal{D} \Vdash \mathcal{P} \mathcal{R} \mathcal{D}' \Vdash \mathcal{P}'$$

where  $\mathcal{R} \in \{\rightarrow, \dashv, \rightarrow\}$ , then  $\vdash \mathcal{D}' \Vdash \mathcal{P}'$ .

Theorem 6.1 is key for the next results, since it assures that the properties enjoyed by well-typed processes are invariant under arbitrarily long process reductions.

The first proper soundness result states that a well-typed process respects the prohibitions expressed by the types of the objects it manipulates. We formulate this property stating that if a well-typed solution contains messages  $m_1, \dots, m_n$  targeted at some object  $a$  and  $a$  has type  $t$ , then there is a valid configuration of  $t$  that includes at least all the  $m_i$ , and possibly more messages.

**Theorem 6.2** (respected prohibitions). *If*

$$\Gamma, a : t \vdash P \mid a.m_1(\tilde{c}_1) \mid \dots \mid a.m_n(\tilde{c}_n),$$

then there exist  $S$  and  $\tilde{s}_i$  such that  $t \leq S \otimes \bigotimes_{i=1..n} m_i(\tilde{s}_i)$ .

The theorem can be rephrased in terms of prohibitions as follows: if the type of an object prohibits invocation of a particular method when the object is in some particular state, then there is no well-typed soup of processes containing pending invocations to that method when the object is in that state. To illustrate, consider the lock object in Listing 1. The type  $t_{lock}$  of the lock we have defined in Section 2 prohibits invocation of method `release` when the lock is in state `FREE`. Also recall that the lock being in the `FREE` state is identified by the presence of the `o.FREE` molecule in the solution. Then, the following judgment is *not* derivable

$$\Gamma, o : t_{lock} \vdash P \mid o.FREE \mid o.release$$

Similarly, the type  $t_{lock}$  states that, when in state `BUSY`, there can be exactly one pending invocation to `release`. So,

$$\Gamma, o : t_{lock} \vdash P \mid o.BUSY \mid o.release \mid o.release$$

is another judgment that cannot be derived. Remarkably, we can infer a great deal of information regarding the state of an object solely looking at its type, knowing virtually nothing about the rest of the (well-typed) program. For instance, no soup containing both a `FREE` and a `BUSY` message simultaneously targeted to the same lock is well typed, meaning that the state of every lock is always uniquely determined.

The second soundness result states that a well-typed process fulfills all the obligations with respect to the objects it owns. More precisely, that if a process  $P$  is typed in an environment that contains a linear object  $a$ , that is an object whose type mandates the (eventual) invocation of a particular method, then  $a$  cannot be discarded by  $P$ , but must be held by  $P$  and used according to its type.

**Theorem 6.3** (weakly fulfilled obligations). *If  $\Gamma \vdash P$  and  $a \in \text{dom}(\Gamma)$  and  $\text{lin}(\Gamma(a))$ , then  $a \in \text{fn}(P)$ .*

Another way of reading this theorem is that well-typed processes can only drop non-linear objects, namely objects for which they have no pending obligations. For example, since  $t_{lock}$  mandates the invocation of method `release` once the lock has been acquired, omitting the `f.release` from line 5 in Listing 4 would result into an ill-typed philosopher.

We have labeled the property stated in Theorem 6.3 “weak” obligation fulfillment because the property may indeed look weaker than desirable. One would probably expect a stronger property saying that every method that must be invoked *is* eventually invoked. Such stronger property, which is in fact a *liveness* property, is however quite subtle to characterize and hard to achieve. In particular, it would require well-typed process to be free from deadlocks, which is something that goes well beyond the capabilities of the type system we have presented in Section 5.

Note that there is one trivial way to honor all pending obligations (as by Theorem 6.3), namely postponing them forever. For example, let

$$\text{forever}(u) \stackrel{\text{def}}{=} \text{def } c = m(x) \triangleright c.m(x) \text{ in } c.m(u)$$

where  $c$  is a fresh name. The judgment  $a : t \vdash \text{forever}(a)$  is derivable provided that  $\text{usable}(t)$ . In particular,  $t$  may be linear, and yet  $\text{forever}(a)$  never invokes any method on  $a$ . Although  $\text{forever}(a)$  fools the type system into believing that all pending obligations on  $a$  have been honored, we think that processes like  $\text{forever}(a)$  are sufficiently contrived to be rarely found in actual code. In other words, we claim that Theorem 6.3 provides practically useful guarantees about the actual use of objects with non-linear types.

Finally, we draw the attention on a general property of the type system that is key for proving Theorem 6.2:

**Lemma 6.4.** *There exist no  $\Gamma$  and  $P$  such that  $\Gamma, u : \emptyset \vdash P$ .*

This property states that there is no well-typed process that can hold an unusable object. The result may look obvious, but it has important consequences: we have remarked the role of subtyping for deducing the interface of objects with uncertain state. For instance,  $t_{\text{BOTH}}$  (Example 4.7) is obtained as the *least upper bound* of  $t_{\text{NONE}}$  and  $t_{\text{SOME}}$ . Since  $\emptyset$  is the top type, the least upper bound of two (or more) types *always* exists, but it can be  $\emptyset$ . For example, had we forgotten to equip the iterator with a peek operation in state `SOME` (line 7 of Listing 2),  $t_{\text{BOTH}}$  would be  $\emptyset$  and the iterator would be essentially unusable. Lemma 6.4 tells us that the type system detects such mistakes.

**Example 6.5.** The side condition in rule [T-MSG-M] requires the arguments of a message to have a usable type. If this condition were not enforced, the following derivation would be legal and Theorem 6.2 would not hold:

$$\frac{\frac{\frac{\vdots}{a : \emptyset \vdash \text{forever}(a)} \quad \frac{\frac{}{\vdash \text{bar} :: \text{bar}} \quad \text{[T-MSG-M]}}{a : \text{bar} \vdash a.\text{bar}} \quad \text{[T-SEND]}}{a : \emptyset \otimes \text{bar} \vdash \text{forever}(a) \mid a.\text{bar}} \quad \text{[T-PAR]}}{a : \text{foo} \vdash \text{forever}(a) \mid a.\text{bar}} \quad \text{[T-SUB]}}$$

Since  $\text{foo} \leq \emptyset \otimes \text{bar} \simeq \emptyset$ , the subsumption rule could be used for allowing spurious method invocations (`bar`) knowing that these would be absorbed by  $\emptyset$  types in other parts of the derivation. Note that the message invocation in *forever(a)* sends an object with type  $\emptyset$ . ■

## 7. Related Work

In [12] class states are represented as invariants describing predicates over fields. They support verification in presence of inheritance and depend on a classification of references as not aliased or possibly aliased. This approach is refined in [1, 5] with a flexible access permission system that permits state changes even in the presence of aliasing. Shared access permissions has been investigated in a concurrent framework in [25], but its integration with the tpestate mechanism is left as future work. In Plaid [27], the tpestate of an object directly corresponds to its class, and that class can change dynamically. Plaid supports the major state modeling features of Statecharts: state hierarchy, *or-states*, and *and-states*, allowing states dimensions to change independently.

The foundations of Plaid and, in general, of TSOP are formally studied in [17] by means of a nominal object-oriented language with mutable state enriched with primitive notions of tpestate change and tpestate checking. The language is equipped with a permission-based type system integrated with a gradual typing mechanism that combines static and dynamic checking. Progress and type preservation properties are formally proved.

To the best of our knowledge, TSOP has been investigated in a concurrent setting only in [9] and partly in [19]. Damiani *et al.* [9] develop a type and effect system for a Java-like

language to trace how the execution of a method changes the state of the receiver object. To forbid access to fields that are not available in the current object’s state, only direct invocations of methods on `this` can change the state of the current object. Since each class method is synchronized, two concurrent threads cannot simultaneously execute in the same object. Our approach relaxes such restrictions. For instance, the full-duplex channel (Example 5.8) can be used in true concurrency by the two peers, and each is statically guaranteed to comply with (its view of) the channel protocol. Gay *et al.* [19] study an integration of tpestate and session types targeting distributed objects. The focus of their work is more on the modularization of sessions across different methods rather than on tpestates themselves. In fact, the work rests on the assumption that *non-uniform* objects (those whose interface changes with time) must be linear.

There is a substantial literature on *behavioral types* which we are not able to fully address here for space limitations. We just remark that most behavioral type theories use *session types* [21] for describing communication protocols. In this respect, our language of behavioral types is an original contribution of this paper and is also the first behavioral type theory for the Objective Join Calculus. The use of explicit continuations for describing structured behaviors is not new. For example, it is at the base of the encoding of session types into linear channel types [10]. Our type system uses essentially the same technique, except that continuations are objects instead of channels. Continuations have been found to be convenient even when types account for structured protocols, to describe the effect of functions on channels [18].

## 8. Concluding remarks

We have found evidence that the Objective Join Calculus is a natural model for TSOP. The choice of this particular model allowed us (1) to approach TSOP in a challenging setting involving concurrency, object sharing/aliasing, and partial/concurrent state updates; (2) to capture the characterizing facets of TSOP (multidimensional state, operations, protocols, aliasing control) with a single, elegant language of behavioral types supported by an intuitive semantics (Section 4); (3) to devise a manageable type system (Section 5) that statically guarantees valuable properties (Section 6) and includes a characterization of safe partial/concurrent state transitions in terms of subtyping (see the side condition of [T-REACTION]).

In this paper we focused on the theoretical foundations of the chemical approach to TSOP, which pave the way to more practical but equally important aspects. Below is a non-exhaustive list of extensions and future developments that we find particularly relevant or intriguing.

**Aliasing.** In our type system, fine-grained aliasing control is realized by the  $\otimes$  connective: an object of type (equivalent to)  $t \otimes s$  can (actually, must) be used according to both  $t$  and  $s$ , by possibly parallel processes. Uncontrolled aliasing re-

quires using the exponential  $*$ . However, neither  $\otimes$  nor  $*$  express with sufficient precision some forms of aliasing/sharing of objects. It would be interesting to investigate whether and how our type language integrates with other forms of aliasing control [5, 13, 25].

**Implementation.** There exist standalone, embedded, and library implementations of the Join Calculus<sup>1</sup> that could be used as the basis for integrating our type system. We think that the Objective Join Calculus equipped with our type theory can also be used as a high-level *specification language* for TSOP to generate corresponding (template) classes for more conventional object-oriented languages.

**Synchronous methods.** Implementations of the Join Calculus support native synchronous methods [3, 14, 15]. Synchronous methods can be easily reflected in the type system using message types of the form  $m(\vec{t}) ; s$  indicating that, after invocation of method  $m$ , the type of the object turns to  $s$ .

**Compiler optimizations.** Efficient compilation techniques for join patterns [23] rely on atomic operations and finite-state automata for tracking the presence messages with a given tag. Our type system paves the way to further optimizations: for example,  $t_{lock}$  says that, when the method `release` is invoked, the lock is *for sure* in state `BUSY`. In other words, the reaction involving `BUSY` and `release` can be triggered without requiring an actual synchronization and invocations to `release` compiled as ordinary method calls.

**Type inference.** Early experiments indicate that it is possible to implement a type inference algorithm for our type system with some minimal help from the programmer. This feature is crucial for the effectiveness of the approach given the use of structural subtyping and the richness of types. We are comforted by the fact that inference of object protocols has been investigated in a number of works (a detailed survey is given in [11]), some of which use specification languages inspired to regular expressions [20] as we do.

**Inheritance.** Inheritance for concurrent objects is a known source of challenging problems. For the Objective Join Calculus, it has been studied in [16], but with a (non-behavioral) type system focused on privacy. We plan to investigate how our type discipline affects the realization of this feature.

## References

[1] J. Aldrich, J. Sunshine, D. Saini, and Z. Sparks. Typestate-oriented programming. In *Proceedings of OOPSLA'09*, pages 1015–1022. ACM, 2009.

[2] N. E. Beckman, D. Kim, and J. Aldrich. An empirical study of object protocols in the wild. In *Proceedings of ECOOP'11*, LNCS 6813, pages 2–26. Springer, 2011.

[3] N. Benton, L. Cardelli, and C. Fournet. Modern concurrency abstractions for C#. *ACM TOPLAS*, 26(5):769–804, 2004.

<sup>1</sup>The Wikipedia page on Join patterns, at the address <http://en.wikipedia.org/wiki/Join-pattern>, contains several pointers.

[4] G. Berry and G. Boudol. The chemical abstract machine. *Theor. Comput. Sci.*, 96(1):217–248, 1992.

[5] K. Bierhoff and J. Aldrich. Modular typestate checking of aliased objects. In *OOPSLA'07*, pages 301–320. ACM, 2007.

[6] J. A. Brzozowski. Derivatives of regular expressions. *J. ACM*, 11(4):481–494, Oct. 1964.

[7] J. Conway. *Regular Algebra and Finite Machines*. William Clowes & Sons Ltd, 1971.

[8] B. Courcelle. Fundamental properties of infinite trees. *Theor. Comp. Sci.*, 25:95–169, 1983.

[9] F. Damiani, E. Giachino, P. Giannini, and S. Drossopoulou. A type safe state abstraction for coordination in Java-like languages. *Acta Inf.*, 45(7-8):479–536, 2008.

[10] O. Dardha, E. Giachino, and D. Sangiorgi. Session types revisited. In *PPDP'12*, pages 139–150. ACM, 2012.

[11] G. de Caso, V. A. Braberman, D. Garbervetsky, and S. Uchitel. Enabledness-based program abstractions for behavior validation. *ACM Trans. Softw. Eng. Methodol.*, 22(3):25, 2013.

[12] R. DeLine and M. Fähndrich. Typestates for objects. In *ECOOP'04*, LNCS 3086, pages 465–490. Springer, 2004.

[13] M. Fähndrich and R. DeLine. Adoption and focus: Practical linear types for imperative programming. In *Proceedings of PLDI'02*, pages 13–24. ACM, 2002.

[14] C. Fournet and G. Gonthier. The reflexive CHAM and the join-calculus. In *POPL'96*, pages 372–385. ACM Press, 1996.

[15] C. Fournet and G. Gonthier. The join calculus: A language for distributed mobile programming. In *Summ. Sch. Appl. Sem.*, LNCS 2395, pages 268–332. Springer, 2000.

[16] C. Fournet, C. Laneve, L. Maranget, and D. Rémy. Inheritance in the join calculus. *J. Logic Alg. Progr.*, 57(12):23–69, 2003.

[17] R. Garcia, É. Tanter, R. Wolff, and J. Aldrich. Foundations of typestate-oriented programming. *ACM TOPLAS*, 36(4):12, 2014.

[18] S. J. Gay and V. T. Vasconcelos. Linear type theory for asynchronous session types. *J.Fun. Progr.*, 20(1):19–50, 2010.

[19] S. J. Gay, V. T. Vasconcelos, A. Ravara, N. Gesbert, and A. Z. Caldeira. Modular session types for distributed object-oriented programming. In *POPL'10*, pages 299–312. ACM, 2010.

[20] T. A. Henzinger, R. Jhala, and R. Majumdar. Permissive interfaces. In *ESEC-FSE'05*, pages 31–40. ACM, 2005.

[21] K. Honda. Types for dyadic interaction. In *Proceedings of CONCUR'93*, LNCS 715, pages 509–523. Springer, 1993.

[22] N. Kobayashi, B. C. Pierce, and D. N. Turner. Linearity and the pi-calculus. *ACM TOPLAS*, 21(5):914–947, 1999.

[23] F. Le Fessant and L. Maranget. Compiling join-patterns. *Electr. Notes Theor. Comput. Sci.*, 16(3):205–224, 1998.

[24] D. Sangiorgi and D. Walker. *The Pi-Calculus - A theory of mobile processes*. Cambridge University Press, 2001.

[25] S. Stork, P. Marques, and J. Aldrich. Concurrency by default: using permissions to express dataflow in stateful programs. In *Proceedings of OOPSLA'09*, pages 933–940. ACM, 2009.

- [26] R. E. Strom and S. Yemini. Typestate: A programming language concept for enhancing software reliability. *IEEE Trans. Software Eng.*, 12(1):157–171, 1986.
- [27] J. Sunshine, K. Naden, S. Stork, J. Aldrich, and É. Tanter. First-class state change in Plaid. In *Proceedings of OOP-SLA'11*, pages 713–732. ACM, 2011.



## A. Proofs

**Definition A.1** (substitution). A *substitution*  $\sigma$  is a map from names to names that differs from the identity for a finite subset of its domain. We write  $\text{dom}(\sigma)$  for the (finite) set of names for which  $\sigma$  is *not* the identity.

**Proposition A.2.** *If  $t \leq s$  and  $\bar{T} = \bar{S}$ , then  $t[T] \leq s[S]$ .*

*Proof.* It is straightforward to see that Definition 5.5 is only affected by the signature of a molecule type and not by the type of the message arguments. Therefore, we can assume  $T = S$  without loss of generality. The result follows by simple arguments using Definition 4.2.  $\square$

**Proposition A.3.** *If  $T_1 \otimes T_2 \leq S_1 \otimes S_2$  and  $\bar{T}_i = \bar{S}_i$  for  $i = 1, 2$  and  $\bar{T}_1 \cap \bar{T}_2 = \emptyset$ , then  $T_i \leq S_i$  for every  $i = 1, 2$ .*

*Proof.* Easy application of Definition 4.2.  $\square$

**Lemma A.4.** *If  $\vdash \mathcal{D} \Vdash \mathcal{P}$  and  $\mathcal{D} \Vdash \mathcal{P} \rightarrow \mathcal{D}' \Vdash \mathcal{P}'$ , then  $\vdash \mathcal{D}' \Vdash \mathcal{P}'$ .*

*Proof.* We reason by cases on the heating rule being applied. We omit discussing rule [COMP-2], as it is similar to [COMP-1].

[NULL] Then  $\mathcal{D}' = \mathcal{D}$  and  $\mathcal{P} = \mathcal{P}', \text{null}$ . From [T-SOLUTION] we deduce that there exist  $\Gamma$  and  $\Delta$  such that  $\Gamma \leq \Delta$  and  $\Gamma \vdash \mathcal{D}$  and  $\Delta \vdash \mathcal{P}$ . From [T-PROCESSES] we deduce that there exist  $\Delta_1$  and  $\Delta_2$  such that  $\Delta = \Delta_1 \otimes \Delta_2$  and  $\Delta_1 \vdash \mathcal{P}'$  and  $\Delta_2 \vdash \text{null}$ . From [T-SUB] and [T-NULL] we deduce  $\text{nl}(\Delta_2)$ , hence  $\Delta \leq \Delta_1$ . We conclude with an application of [T-SOLUTION].

[DEF] Then  $\mathcal{D}' = \mathcal{D}, a = C$  and  $\mathcal{P} = \mathcal{P}', \text{def } a = C \text{ in } P$  and  $\mathcal{P}' = \mathcal{P}'', P$  and  $a \notin \text{fn}(\mathcal{P}'')$ . From [T-SOLUTION] we deduce that there exist  $\Gamma$  and  $\Delta$  such that  $\Gamma \leq \Delta$  and  $\Gamma \vdash \mathcal{D}$  and  $\Delta \vdash \mathcal{P}$ . From [T-PROCESSES] we deduce that there exist  $\Delta_1$  and  $\Delta_2$  such that  $\Delta = \Delta_1 \otimes \Delta_2$  and  $\Delta_1 \vdash \mathcal{P}''$  and  $\Delta_2 \vdash \text{def } a = C \text{ in } P$ . From [T-SUB] and [T-OBJECT] we deduce that there exists  $t$  and  $\Delta'_2$  such that  $\Delta_2 \leq \Delta'_2$  and  $a : t \vdash C$  and  $\Delta'_2, a : t \vdash P$ . Using the hypothesis  $a \notin \text{fn}(\mathcal{P}'')$  we can assume, without loss of generality, that  $a \notin \text{dom}(\Gamma)$ . Let  $\Gamma' \stackrel{\text{def}}{=} \Gamma, a : t$  and  $\Delta' \stackrel{\text{def}}{=} \Delta_1, \Delta_2, a : t$  and observe that  $\Gamma' \leq \Delta'$ . We conclude  $\vdash \mathcal{D}' \Vdash \mathcal{P}'$ .

[COMP-1] Then  $\mathcal{D}' = \mathcal{D}$  and  $\mathcal{P} = \mathcal{P}'', P_1 \mid P_2$  and  $\mathcal{P}' = \mathcal{P}'', P_1, P_2$ . From [T-SOLUTION] we deduce that there exist  $\Gamma$  and  $\Delta$  such that  $\Gamma \leq \Delta$  and  $\Gamma \vdash \mathcal{D}$  and  $\Delta \vdash \mathcal{P}$ . From [T-PROCESSES] we deduce that there exist  $\Delta_1$  and  $\Delta_2$  such that  $\Delta = \Delta_1 \otimes \Delta_2$  and  $\Delta_1 \vdash \mathcal{P}''$  and  $\Delta_2 \vdash P_1 \mid P_2$ . From [T-SUB] and [T-PAR] we deduce that there exist  $\Delta_{21}$  and  $\Delta_{22}$  such that  $\Delta_2 \leq \Delta_{21} \otimes \Delta_{22}$  and  $\Delta_{2i} \vdash P_i$  for  $i = 1, 2$ . We conclude with an application of [T-PROCESSES] and one of [T-SOLUTION].  $\square$

**Lemma A.5.** *If  $\vdash \mathcal{D} \Vdash \mathcal{P}$  and  $\mathcal{D} \Vdash \mathcal{P} \rightarrow \mathcal{D}' \Vdash \mathcal{P}'$ , then  $\vdash \mathcal{D}' \Vdash \mathcal{P}'$ .*

*Proof.* We reason by cases on the heating rule being applied. We omit discussing rule [COMP-2], as it is similar to [COMP-1].

[NULL] Then  $\mathcal{D}' = \mathcal{D}$  and  $\mathcal{P}' = \mathcal{P}, \text{null}$ . The result is immediate as  $\text{null}$  is well typed in the empty environment.

[DEF] Then  $\mathcal{D} = \mathcal{D}', a = C$  and  $\mathcal{P} = \mathcal{P}'', P$  and  $\mathcal{P}' = \mathcal{P}'', \text{def } a = C \text{ in } P$  and  $a \notin \text{fn}(\mathcal{P}'')$ . From [T-SOLUTION] we deduce that there exist  $\Gamma$  and  $\Delta$  such that  $\Gamma \leq \Delta$  and  $\Gamma \vdash \mathcal{D}$  and  $\Delta \vdash \mathcal{P}$ . From [T-DEFINITIONS] we deduce that  $\Gamma = \Gamma', a : t$  and  $a : t \vdash C$ . From [T-PROCESSES] we deduce that there exist  $\Delta_1$  and  $\Delta_2$  such that  $\Delta = \Delta_1 \otimes \Delta_2$  and  $\Delta_1 \vdash \mathcal{P}''$  and  $\Delta_2 \vdash P$ . From the hypothesis  $a \notin \text{fn}(\mathcal{P}'')$  we can assume, without loss of generality, that  $a \in \text{dom}(\Delta_2) \setminus \text{dom}(\Delta_1)$ . That is,  $\Delta_2 = \Delta'_2, a : s$  where  $t \leq s$ . We conclude by [T-SUB] and [T-OBJECT].

[COMP-1] Then  $\mathcal{D} = \mathcal{D}'$  and  $\mathcal{P} = \mathcal{P}'', P_1, P_2$  and  $\mathcal{P}' = \mathcal{P}'', P_1 \mid P_2$ . From [T-SOLUTION] we deduce that there exist  $\Gamma$  and  $\Delta$  such that  $\Gamma \leq \Delta$  and  $\Gamma \vdash \mathcal{D}$  and  $\Delta \vdash \mathcal{P}$ . From [T-PROCESSES] we deduce that there exist  $\Delta_1, \Delta_2$ , and  $\Delta_3$  such that  $\Delta_1 \vdash \mathcal{P}''$  and  $\Delta_2 \vdash P_1$  and  $\Delta_3 \vdash P_2$ . By [T-PAR] we obtain  $\Delta_2 \otimes \Delta_3 \vdash P_1 \mid P_2$ . We conclude with one application of [T-PROCESSES] and one of [T-SOLUTION].  $\square$

**Definition A.6** (environment substitution). The application of  $\sigma$  to the environment  $\Gamma$  is the environment  $\sigma\Gamma$  defined by:

$$\sigma\Gamma \stackrel{\text{def}}{=} \bigotimes_{u \in \text{dom}(\Gamma)} \sigma(u) : \Gamma(u)$$

**Proposition A.7.** *The following properties hold:*

1.  $\sigma(\Gamma \otimes \Delta) = \sigma\Gamma \otimes \sigma\Delta$ ;
2.  $\Gamma \leq \Delta$  implies  $\sigma\Gamma \leq \sigma\Delta$ .

*Proof.* Easy applications of Definitions 5.1, 5.2, and A.6.  $\square$

**Lemma A.8.** *If  $\Gamma \vdash J :: T$  and  $\Delta \vdash \sigma J :: S$  and  $T \leq S$ , then  $\Delta \leq \sigma\Gamma$ .*

*Proof.* By induction on  $J$  and by cases on its shape.

[ $J = \mathbf{m}(\bar{x})$ ] Then  $\Gamma = \{x_i : t_i\}_{i=1..n}$  and  $T = \mathbf{m}(t_1, \dots, t_n)$  and  $\sigma J = \mathbf{m}(u_1, \dots, u_n)$  and  $S = \mathbf{m}(s_1, \dots, s_n)$  and  $\Delta = \bigotimes_{i=1..n} u_i : s_i$ . From the hypothesis  $T \leq S$  we deduce  $s_i \leq t_i$  for every  $i = 1..n$ .

To prove  $\Delta \leq \sigma\Gamma$ , observe that  $\text{dom}(\sigma\Gamma) = \{u_1, \dots, u_n\} \subseteq \text{dom}(\Delta)$ . Now we distinguish two subcases. If  $u \in \text{dom}(\Delta) \setminus \text{dom}(\sigma\Gamma)$ , then  $u$  cannot be any of the  $u_i$ , hence  $\text{nl}(\Delta(u))$ . If  $u \in \text{dom}(\sigma\Gamma)$ , we have

$$\begin{aligned} (\sigma\Gamma)(u) &= \bigotimes_{v \in \text{dom}(\Gamma), u = \sigma(v)} \Gamma(v) && \text{by Definition A.6} \\ &= \bigotimes_{i=1..n, u = \sigma(x_i)} \Gamma(x_i) && \text{by definition of } \Gamma \\ &= \bigotimes_{i=1..n, u = u_i} t_i && \text{by def. of } \sigma \text{ and } \Gamma \end{aligned}$$

and furthermore  $\Delta(u) = \bigotimes_{i=1..n, u = u_i} s_i$ . We conclude  $(\sigma\Gamma)(u) \leq \Delta(u)$  from the fact that  $s_i \leq t_i$  and pre-congruence of  $\leq$ .

$J = J_1 \mid J_2$  Then  $\Gamma = \Gamma_1, \Gamma_2$  and  $T = T_1 \otimes T_2$  and  $\Delta = \Delta_1 \otimes \Delta_2$  and  $S = S_1 \otimes S_2$  and  $\Gamma_i \vdash J_i :: T_i$  and  $\Delta_i \vdash \sigma J_i :: S_i$  for every  $i = 1, 2$ . Since  $T_1$  and  $T_2$  have disjoint signatures, and so do  $S_1$  and  $S_2$ , from the hypothesis  $T \leq S$  and Proposition A.3 we deduce  $T_i \leq S_i$  for every  $i = 1, 2$ . By induction hypothesis we deduce that  $\Delta_i \leq \sigma \Gamma_i$  for every  $i = 1, 2$ . We conclude  $\Delta = \Delta_1 \otimes \Delta_2 \leq \sigma \Gamma_1 \otimes \sigma \Gamma_2 = \sigma(\Gamma_1, \Gamma_2) = \sigma \Gamma$  by pre-congruence of  $\leq$  and Proposition A.7(1).  $\square$

**Lemma A.9.** *If  $\Gamma \vdash M :: T$ , then  $\sigma \Gamma \vdash \sigma M :: T$ .*

*Proof.* By induction on the derivation of  $\Gamma \vdash M :: T$  and by cases on the last rule applied.

$\boxed{[\text{T-MSG-M}]}$  Then  $M = m(u_1, \dots, u_n)$  and  $\Gamma = \bigotimes_{i=1..n} u_i : t_i$  and  $\text{usable}(t_1, \dots, t_n)$ . By Proposition A.7(1) we deduce  $\sigma \Gamma = \bigotimes_{i=1..n} \sigma(u_i) : t_i$ . We conclude with one application of  $\boxed{[\text{T-MSG-M}]}$  observing that  $\sigma M = m(\sigma(u_1), \dots, \sigma(u_n))$ .

$\boxed{[\text{T-COMP-M}]}$  Then  $M = M_1 \mid M_2$  and  $\Gamma = \Gamma_1 \otimes \Gamma_2$  and  $T = T_1 \otimes T_2$  and  $\Gamma_i \vdash M_i :: T_i$  for every  $i = 1, 2$ . By induction hypothesis we deduce  $\sigma \Gamma_i \vdash \sigma M_i :: T_i$ . We conclude with one application of  $\boxed{[\text{T-COMP-M}]}$  observing that  $\sigma M = \sigma M_1 \mid \sigma M_2$  and by Proposition A.7(1).  $\square$

**Lemma A.10.** *If  $\Gamma \vdash P$ , then  $\sigma \Gamma \vdash \sigma P$ .*

*Proof.* By induction on the derivation of  $\Gamma \vdash P$  and by cases on the last rule applied.

$\boxed{[\text{T-NULL}]}$  Immediate.

$\boxed{[\text{T-SEND}]}$  Then  $P = u.M$  and  $\Gamma = \Delta \otimes u : T$  and  $\Delta \vdash M :: T$ . By Lemma A.9 we deduce  $\sigma \Delta \vdash \sigma M :: T$ . By  $\boxed{[\text{T-SEND}]}$  we derive  $\sigma \Delta \otimes \sigma(u) : T \vdash \sigma(u). \sigma M$ . We conclude by Proposition A.7(1).

$\boxed{[\text{T-PAR}]}$  Then  $P = P_1 \mid P_2$  and  $\Gamma = \Gamma_1 \otimes \Gamma_2$  and  $\Gamma_i \vdash P_i$  for every  $i = 1, 2$ . By induction hypothesis we deduce  $\sigma \Gamma_i \vdash \sigma P_i$  for every  $i = 1, 2$ . We conclude by Proposition A.7(1) and one application of  $\boxed{[\text{T-PAR}]}$ , observing that  $\sigma P = \sigma P_1 \mid \sigma P_2$ .

$\boxed{[\text{T-OBJECT}]}$  Then  $P = \text{def } a = C \text{ in } Q$  and there exists  $t$  such that  $a : t \vdash C$  and  $\Gamma, a : t \vdash Q$ . Without loss of generality we may assume that  $a \notin \sigma(\text{dom}(\Gamma))$ , so that  $\sigma(\Gamma, a : t) = \sigma \Gamma, a : t$ . By induction hypothesis we deduce  $\sigma(\Gamma, a : t) \vdash \sigma Q$ . We conclude with one application of  $\boxed{[\text{T-OBJECT}]}$ .

$\boxed{[\text{T-SUB}]}$  Then there exists  $\Delta$  such that  $\Gamma \leq \Delta$  and  $\Delta \vdash P$ . By induction hypothesis we deduce  $\sigma \Delta \vdash \sigma P$ . We conclude by Proposition A.7(2) and one application of  $\boxed{[\text{T-SUB}]}$ .  $\square$

**Lemma A.11.** *If  $t \downarrow T$  and  $t \leq s \otimes S$  and  $\text{usable}(s)$  and  $\bar{T} = \bar{S}$ , then  $T \leq S$ .*

*Proof.* Let  $R \in \llbracket s \rrbracket$ . Such  $R$  exists from the hypothesis  $\text{usable}(s)$ . Then  $R \otimes S \in \llbracket s \otimes S \rrbracket$ . From the hypothesis  $t \leq s \otimes S$  we deduce that there exists  $R'$  such that  $R' \otimes T \in \llbracket t \rrbracket$  and  $R' \otimes T \leq R \otimes S$ . From the hypothesis  $t \downarrow T$  we deduce that if  $T$  contains some  $M_1$  and  $R'$  contains some  $M_2$  such that  $M_1$  and  $M_2$  have the same tag, then  $M_1 = M_2$ . It follows that  $T \leq S$ .  $\square$

**Lemma A.12.** *If  $\vdash \mathcal{D} \Vdash \mathcal{P}$  and  $\mathcal{D} \Vdash \mathcal{P} \rightarrow \mathcal{D} \Vdash \mathcal{P}'$ , then  $\vdash \mathcal{D} \Vdash \mathcal{P}'$ .*

*Proof.* We have  $\mathcal{D} = \mathcal{D}', a = \{J_i \triangleright P_i\}_{i \in I}$  and  $\mathcal{P} = \mathcal{P}'', a. \sigma J_k$  and  $\mathcal{P}' = \mathcal{P}'', \sigma P_k$  for some  $k \in I$ . Without loss of generality, we may assume that  $a \notin \text{dom}(\sigma)$ . From  $\boxed{[\text{T-SOLUTION}]}$  we deduce that there exist  $\Gamma$  and  $\Delta$  such that  $\Gamma \leq \Delta$  and  $\Gamma \vdash \mathcal{D}$  and  $\Delta \vdash \mathcal{P}$ . From  $\boxed{[\text{T-DEFINITIONS}]}$  we deduce that there exist  $t$  such that  $\Gamma(a) = t$  and  $a : t \vdash \{J_i \triangleright P_i\}_{i \in I}$ . From  $\boxed{[\text{T-CLASS}]}$  and  $\boxed{[\text{T-REACTION}]}$  we deduce that there exist  $\Gamma_0, T$ , and  $s$  such that (1)  $\Gamma_0 \vdash J_k :: T$  and (2)  $\Gamma_0, a : s \vdash P_k$  and furthermore (3)  $t \downarrow T$ , and (4)  $t \leq t[T] \otimes s$ . From  $\boxed{[\text{T-PROCESSES}]}$  we deduce that there exist  $\Delta_1, \Delta_2, t_1$ , and  $t_2$  such that  $\Delta = (\Delta_1, a : t_1) \otimes (\Delta_2, a : t_2)$  and  $\Delta_1, a : t_1 \vdash \mathcal{P}''$  and  $\Delta_2, a : t_2 \vdash a. \sigma J_k$  (if  $a \notin \text{fn}(\mathcal{P}'')$  we can take  $t_1 = \mathbb{1}$ ). From  $\boxed{[\text{T-SUB}]}$  and  $\boxed{[\text{T-SEND}]}$  we deduce that there exist  $\Delta'_2, t_3$ , and  $S$  such that  $\Delta_2 \leq \Delta'_2$  and  $t_2 \leq t_3 \otimes S$  and (5)  $\Delta'_2, a : t_3 \vdash \sigma J_k :: S$ . Overall, we have (6)  $t \leq t_1 \otimes t_3 \otimes S$ . Furthermore, it must be the case that  $\bar{T} = \bar{S}$  for  $T$  and  $S$  are molecule types for molecules with the same signature. From (3) and Lemma A.11, we deduce  $T \leq S$ . From (1), (5), and Lemma A.8, we deduce that  $\Delta'_2, a : t_3 \leq \sigma \Gamma_0$ . By pre-congruence of  $\leq$ , we deduce that  $\Delta'_2, a : t_3 \otimes s \leq \sigma \Gamma_0 \otimes a : s$  therefore we can derive  $\Delta_2, a : t_3 \otimes s \vdash \sigma P_k$  using (2) and  $(\Delta_1 \otimes \Delta_2), a : t_1 \otimes t_3 \otimes s \vdash \mathcal{P}'', \sigma P_k$  with an application of  $\boxed{[\text{T-PROCESSES}]}$ . From (6) and Proposition A.2 we deduce  $t[T] \leq t_1 \otimes t_3$ . We conclude  $t \leq t_1 \otimes t_3 \otimes s$  using (4) and pre-congruence of  $\leq$ .  $\square$

**Theorem 6.1.** *If  $\vdash \mathcal{D} \Vdash \mathcal{P}$  and  $\mathcal{D} \Vdash \mathcal{P} \mathcal{R} \mathcal{D}' \Vdash \mathcal{P}'$  where  $\mathcal{R} \in \{\rightarrow, \rightarrow, \rightarrow\}$ , then  $\vdash \mathcal{D}' \Vdash \mathcal{P}'$ .*

*Proof.* Consequence of Lemmas A.4, A.5 and A.12.  $\square$

**Lemma A.13.**  $\Gamma \vdash M :: T$  implies  $\text{usable}(\Gamma)$ .

*Proof.* By induction on the derivation of  $\Gamma \vdash M :: T$  and by cases on the last rule applied.

$\boxed{[\text{T-MSG-M}]}$  Then  $M = m(u_1, \dots, u_n)$  and  $\Gamma = \bigotimes_{i=1..n} u_i : t_i$  where  $\text{usable}(t_1, \dots, t_n)$ . The result follows immediately.

$\boxed{[\text{T-COMP-M}]}$  Then  $\Gamma = \Gamma_1 \otimes \Gamma_2$  and  $M = M_1 \mid M_2$  and  $T = T_1 \otimes T_2$  and  $\Gamma_i \vdash M_i :: T_i$  for  $i = 1, 2$ . By induction hypothesis we deduce  $\text{usable}(\Gamma_i)$  for every  $i = 1, 2$ . We conclude  $\text{usable}(\Gamma)$  since  $\text{usable}(s_1)$  and  $\text{usable}(s_2)$  imply  $\text{usable}(s_1 \otimes s_2)$ .  $\square$

The following Lemma is an equivalent reformulation of Lemma 6.4.

**Lemma A.14.**  $\Gamma \vdash P$  implies usable( $\Gamma$ ).

*Proof.* By induction on the derivation of  $\Gamma \vdash P$  and by cases on the last rule applied. We only show a few cases.

[T-NULL] Trivial.

[T-SEND] Consequence of Lemma A.13.

[T-SUB] Then  $\Delta \vdash P$  where  $\Gamma \leq \Delta$ . By induction hypothesis we deduce usable( $\Delta$ ). We conclude usable( $\Gamma$ ) by Definition 5.2 since  $\text{nl}(t)$  implies usable( $t$ ).  $\square$

**Theorem 6.2.** If  $\Gamma, a : t \vdash \mathcal{P}, a.\mathfrak{m}_1(\tilde{c}_1), \dots, a.\mathfrak{m}_n(\tilde{c}_n)$ , then there exist  $S$  and  $\tilde{s}_i$  such that  $t \leq S \otimes \bigotimes_{i=1..n} \mathfrak{m}_i(\tilde{s}_i)$ .

*Proof.* From the hypothesis and [T-PROCESSES] we deduce that there exist  $\Gamma_i$  and  $t_i$  for  $i \in \{0, \dots, n\}$  such that  $\Gamma = \bigotimes_{i=0..n} \Gamma_i$  and  $t = \bigotimes_{i=0..n} t_i$  and  $\Gamma_0, a : t_0 \vdash \mathcal{P}$  and  $\Gamma_i, a : t_i \vdash a.\mathfrak{m}_i(\tilde{c}_i)$  for every  $i = 1..n$ . If  $a \notin \text{fn}(\mathcal{P})$ , we can take  $t_0 = \mathbb{1}$  without loss of generality. From [T-SUB] and [T-SEND] we deduce that, for every  $i = 1..n$ , there exist  $\tilde{s}_i$  and  $\mathfrak{m}_i$  such that  $t_i \leq \mathfrak{m}_i(\tilde{s}_i)$ . From Lemma A.14 we deduce usable( $t_0$ ), namely there exist  $S \in \llbracket t_0 \rrbracket$ . We conclude  $t = \bigotimes_{i=0..n} t_i \leq S \otimes \bigotimes_{i=1..n} \mathfrak{m}_i(\tilde{s}_i)$  by definition of  $t$  and pre-congruence of  $\leq$ .  $\square$

Note that there is no molecule type  $S$  such that  $S \simeq \emptyset$ , hence the property in Theorem 6.2 cannot be satisfied trivially.

**Lemma A.15.** If  $\Gamma \vdash M :: T$  and  $u \in \text{dom}(\Gamma) \setminus \text{fn}(M)$ , then  $\text{nl}(\Gamma(u))$ .

*Proof.* Easy induction on the derivation of  $\Gamma \vdash M :: T$ .  $\square$

**Theorem 6.3.** If  $\Gamma \vdash P$  and  $a \in \text{dom}(\Gamma)$  and  $\text{lin}(\Gamma(a))$ , then  $a \in \text{fn}(P)$ .

*Proof.* We prove an equivalent property, namely that  $\Gamma \vdash P$  and  $a \in \text{dom}(\Gamma) \setminus \text{fn}(P)$  imply  $\text{nl}(\Gamma(a))$ . We proceed by induction on the derivation of  $\Gamma \vdash P$  and by cases on the last rule applied.

[T-NULL] Immediate.

[T-SEND] Then  $\Gamma = \Gamma' \otimes u : T$  and  $P = u.M$  and  $\Gamma' \vdash M :: T$ . Let  $a \in \text{dom}(\Gamma) \setminus \text{fn}(P)$ . Then  $a \neq u$  and  $a \in \text{dom}(\Gamma') \setminus \text{fn}(M)$ . The result follows from Lemma A.15.

[T-PAR] Then  $\Gamma = \Gamma_1 \otimes \Gamma_2$  and  $P = P_1 \mid P_2$  and  $\Gamma_i \vdash P_i$  for every  $i = 1, 2$ . By induction hypothesis,  $a \in \text{dom}(\Gamma_i) \setminus \text{fn}(P_i)$  implies  $\text{nl}(\Gamma_i(a))$  for every  $i = 1, 2$ . We conclude by observing that  $\text{dom}(\Gamma) = \text{dom}(\Gamma_1) \cup \text{dom}(\Gamma_2)$  and  $\text{fn}(P) = \text{fn}(P_1) \cup \text{fn}(P_2)$ .

[T-OBJECT] Then  $P = \text{def } c = C \text{ in } Q$  and  $\Gamma, c : t \vdash Q$  where, without loss of generality, we may assume  $a \neq c$ . By induction hypothesis we deduce that  $a \in (\text{dom}(\Gamma) \cup \{c\}) \setminus \text{fn}(Q)$  implies  $\text{nl}(\Gamma(a))$ . We conclude by observing that  $\text{fn}(P) = \text{fn}(Q) \setminus \{c\}$ .

[T-SUB] Then  $\Delta \vdash P$  for some  $\Delta$  such that  $\Gamma \leq \Delta$ . Recall that  $\text{dom}(\Delta) \subseteq \text{dom}(\Gamma)$  by Definition 5.2. Let  $a \in \text{dom}(\Gamma) \setminus \text{fn}(P)$ . We distinguish two sub-cases: if  $a \in \text{dom}(\Delta)$ , then we conclude using the induction hypothesis; if  $a \notin \text{dom}(\Delta)$ , then  $\text{nl}(\Gamma(a))$  by Definition 5.2.  $\square$