



HAL
open science

Sensor fault tolerant control of nonlinear Takagi-Sugeno systems. Application to vehicle lateral dynamics

Dalil Ichalal, Benoît Marx, José Ragot, Saïd Mammar, Didier Maquin

► To cite this version:

Dalil Ichalal, Benoît Marx, José Ragot, Saïd Mammar, Didier Maquin. Sensor fault tolerant control of nonlinear Takagi-Sugeno systems. Application to vehicle lateral dynamics. International Journal of Robust and Nonlinear Control, 2016, 26 (7), pp.1376-1394. 10.1002/rnc.3355 . hal-01143716

HAL Id: hal-01143716

<https://hal.science/hal-01143716v1>

Submitted on 27 Feb 2023

HAL is a multi-disciplinary open access archive for the deposit and dissemination of scientific research documents, whether they are published or not. The documents may come from teaching and research institutions in France or abroad, or from public or private research centers.

L'archive ouverte pluridisciplinaire **HAL**, est destinée au dépôt et à la diffusion de documents scientifiques de niveau recherche, publiés ou non, émanant des établissements d'enseignement et de recherche français ou étrangers, des laboratoires publics ou privés.



Distributed under a Creative Commons Attribution 4.0 International License

Sensor fault tolerant control of nonlinear Takagi-Sugeno systems. Application to vehicle lateral dynamics

Dalil Ichalal^{1,*}, Benoît Marx^{2,3}, José Ragot^{2,3}, Said Mammar¹ and Didier Maquin^{2,3}

¹Laboratoire d'Informatique, Biologie Intégrative et Systèmes Complexes (IBISC), Université d'Evry Val d'Essonne, 40, rue de Pelvoux, Courcouronnes, 91080 Cedex, France.

² Université de Lorraine, Centre de Recherche en Automatique de Nancy, UMR 7039, 2 avenue de la Forêt de Haye, 54516 Vandoeuvre-lès-Nancy, France.

³ CNRS, CRAN, UMR 7039, France.

SUMMARY

This paper presents a new scheme for sensor fault tolerant control for nonlinear systems based on the Takagi-Sugeno modeling. First, a structured residual generator aiming at detecting and isolating sensor faults is designed. A bank of observers controlled either by only one system output or a set of outputs is then implemented leading to a set of state estimates. The parallel distributed compensation structure is adopted to design the fault tolerant controller. The novelty in this paper is that the estimated state used in the controller is a weighted state vector obtained from all the estimated states provided by the different observers. The weighting functions depend on the residual vector signals delivered by the residual generator. They are designed to avoid crisp switches in the control law. Indeed, the interesting feature of the proposed approach is to avoid the commonly used switching strategy. For each residual component, the greater its magnitude is, the less the weight affected to the corresponding state estimate is. Consequently, the controller only uses estimations computed on the basis of healthy measurements. The closed-loop stability is studied with the Lyapunov theory and the obtained conditions are expressed as a set of Linear Matrix Inequalities. The proposed residual generation and fault tolerant controller are applied to a vehicle lateral dynamics affected by sensor faults. Copyright © 2014 John Wiley & Sons, Ltd.

KEY WORDS: Fault-tolerant control; Takagi-Sugeno models; sensor fault; vehicle lateral dynamics

1. INTRODUCTION

Fault diagnosis takes a primordial place in the modern control systems. Indeed, human safety and system performance preservation are crucial specifications which should be taken into account upstream of the control design. For that purpose, a fault detection and isolation system is required to detect occurred faults in the process. However, a diagnosis system is not sufficient to preserve system

performances and human security. The controller must be designed to guarantee the stability of the system even in faulty situations. This second task is commonly called Fault Tolerant Control (FTC) and has been classified into two different classes: the first one, called Passive Fault Tolerant Control

(PFTC) is an extension of the well-known robust control. It requires the knowledge of all possible faults which may affect the system (generally the magnitude of these faults). The structure of the controller is chosen *a priori* in order to be robust to all inventoried faults (no adaptation is performed online). This type of control is interesting since no fault diagnosis module is needed. However, its

main disadvantages is the impossibility to consider unknown faults and the conservativeness of design conditions. Unlike the PFTC techniques, the Active Fault Tolerant Control (AFTC) offers some flexibilities in the design task. It can be assimilated to a variable structure technique since the structure of the controller can be automatically modified and reconfigured when a fault occurs. In addition, it is no longer necessary to list all possible faults in the system. A Fault Detection and Isolation (FDI) module is incorporated in the control unit. It provides information on the occurred faults to the FTC unit which reconfigures the control strategy to compensate and to accommodate them.

In the recent years, the rapid growth of demand in terms of performance and safety for the systems as well as the human operator requires to consider more realistic models of the studied systems. Therefore, nonlinear mathematical models are often developed. Because of the complexity of such models, there is no general framework for their analysis, control and diagnosis. Thus, only specific classes of nonlinear models are studied (Lipschitz systems, Linear Parameter Varying (LPV) systems, output or state feedback linearizable systems, ...). In the proposed work, the considered models are in the Takagi-Sugeno's form (T-S).

This kind of model is mainly used with regards to its property of "universal approximator" of any nonlinear system based on the sector nonlinearity approach [1]. Indeed, any nonlinear system can be approximated with a given accuracy or represented exactly with such a structure [1]. A T-S model can be obtained using three main methods: linearization around a set of operating points [2], identification [3, 4] and sector nonlinearity transformation approach [1].

The analysis and control of nonlinear systems via T-S modeling have attracted many researchers. This model allows the study of many stability and stabilization problems [1, 5, 6, 7]. The common core of the proposed approaches is the use of the Lyapunov theory to establish stability conditions which are often expressed in terms of Linear Matrix Inequalities (LMIs). This fact constitutes one of the advantages of the T-S approach. Indeed, the particular structure of the T-S models allows the exploitation and the extension to nonlinear domain of some theories, tools and methods, initially developed for linear systems. Firstly, classic quadratic Lyapunov functions were considered but it soon became clear that such functions often lead to conservative conditions, especially for a large number of sub-models. The concern to reduce this conservatism led to develop other types of Lyapunov functions (poly-quadratic, non-quadratic,...) [8, 9] and other approaches such as Tuan's relaxation [10] or Polya's theorem [11]. These approaches are extended in [12, 13, 14, 15] for observer design applied to state and unknown input estimation. These observers are used for fault diagnosis in [13, 15, 16, 17]. The design of fault tolerant control for T-S systems has also been studied. State trajectory tracking is proposed in [18] for actuator faults.

In [19], a bank of controllers is implemented, each of them is designed separately and generates a control law based on the state estimate $\hat{x}^k(t)$. Based on a residual analysis, a switching strategy is then developed in order to select the control law relying on a fault-free state estimate. Unfortunately, the stability of the whole closed-loop system is not studied. Only the stability of each observer-based controller is provided and no stability at the switching instants is guaranteed (it is well known that stable sub-systems do not necessarily lead to stable switched system [20]).

Similar and more interesting approach is proposed in [21] where linear discrete-time system is considered. The approach is based on constructing controllers from each output, the control input applied to the system is selected by an adequate switching strategy in the presence of sensor faults. The switching mechanism is designed in such a way to guarantee a minimal cost and select the adequate controller that eliminates the effect of the occurred fault with guaranteed cost.

In the present paper a new FTC design for nonlinear systems affected by disturbance and sensor faults is proposed. The overall idea is to use fault diagnosis in order to distinguish between faulty and healthy sensors and then only use the measurements provided by the later ones to produce a state estimate and a control law. Firstly, an observer based residual generator is designed. Secondly, a bank of observers is constructed where each observer is fed with all the inputs and only one measured output. As a consequence the state estimate produced by the k^{th} observer is only affected by the k^{th} sensor fault. Thirdly, a state estimate is obtained by blending the different estimates with time varying weights computed from the residual in order to mainly use the ones based

on healthy sensors: if a given sensor fault is isolated, the weight of the corresponding estimated state is lowered. Thus, the influence of corrupted measures in the state estimation is minimized. Finally, a FT parallel distributed control (PDC) law is computed based on this blended state estimate.

Notations. The terms 0_n and I_n respectively define the null square matrix and the identity matrix with dimension n . The non square null matrix is defined by $0_{p \times n}$ with dimension $p \times n$. In order to shorten the summation, the following notations for polytopic matrices are defined

$$X_\mu = \sum_{i=1}^r \mu_i(\xi(t)) X_i \quad \text{and} \quad X_{\mu\mu} = \sum_{i=1}^r \sum_{j=1}^r \mu_i(\xi(t)) \mu_j(\xi(t)) X_{ij}$$

Lemma 1

For any matrices X and Y with appropriate dimensions and any symmetric positive definite matrix Λ , the following inequality holds

$$X^T Y + Y^T X \leq X^T \Lambda^{-1} X + Y^T \Lambda Y \quad (1)$$

Lemma 2

(Congruence lemma) Consider two matrices X and Y . If X is positive (resp. negative) definite and Y is full column rank then $Y X Y^T$ is positive (resp. negative) definite.

Lemma 3

For any scalar β , matrix Q and symmetric positive definite matrix Λ , the following inequalities hold

$$(Q - \beta \Lambda^{-1})^T \Lambda (Q - \beta \Lambda^{-1}) \geq 0 \Leftrightarrow -Q^T \Lambda Q \leq -\beta (Q + Q^T) + \beta^2 \Lambda^{-1} \quad (2)$$

2. TAKAGI-SUGENO MODELING

A nonlinear dynamic system affected by disturbance and additive sensor fault is generally represented by:

$$\begin{cases} \dot{x}(t) = g(x(t), u(t), d(t)) \\ y(t) = h(x(t), d(t)) + f(t) \end{cases} \quad (3)$$

where $x(t) \in \mathbb{R}^n$ denotes the state vector, $u(t) \in \mathbb{R}^m$ is the control input and $y(t) \in \mathbb{R}^p$ represents the system output vector, $d(t) \in \mathbb{R}^{n_d}$ is the disturbance vector (noises, external perturbations,...) and $f(t) \in \mathbb{R}^p$, the additive sensor fault vector. The functions g and h are nonlinear smooth functions satisfying $g(0, 0, 0) = 0$ and $h(0, 0) = 0$. As explained in the previous section, the Takagi-Sugeno model is an interesting alternative to study nonlinear systems. It describes nonlinear behaviors while having a structure based on linear models allowing the extension of some tools from the linear domain to the nonlinear one. Using identification [3, 4], linearization [2], or the so-called sector nonlinearity transformation [1, 22], a T-S model for the system (3) can be obtained under the following form:

$$\begin{cases} \dot{x}(t) = \sum_{i=1}^r \mu_i(\xi(t)) (A_i x(t) + B_i u(t) + E_i d(t)) \\ y(t) = \sum_{i=1}^r \mu_i(\xi(t)) (C_i x(t) + G_i d(t)) + f(t) \end{cases} \quad (4)$$

where $A_i \in \mathbb{R}^{n \times n}$, $B_i \in \mathbb{R}^{n \times m}$, $C_i \in \mathbb{R}^{p \times n}$, $E_i \in \mathbb{R}^{n \times n_d}$ and $G_i \in \mathbb{R}^{p \times n_d}$ are the matrices describing the so-called i^{th} sub-model. The integer r represents the number of sub-models. If the T-S model is obtained by identification or linearization, the accuracy of the model depends on the number r of sub-models. Indeed, a more accurate T-S model is obtained when increasing the value of r . If the T-S model is obtained by sector nonlinearity transformation, r depends on the number nl of nonlinearities in the model (3) and $r = 2^{nl}$. The weighing functions μ_i are nonlinear and depend on the premise variable $\xi(t)$ which can be measurable (e.g. $u(t)$ or $y(t)$) or not measurable (e.g. $x(t)$). It is commonly assumed in LPV and switched systems that these parameters are not known

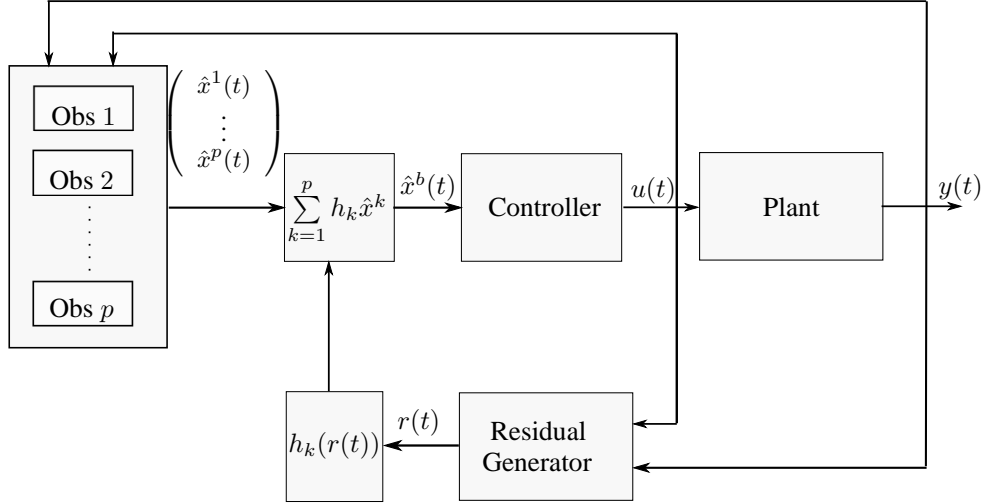

Figure 1. Sensor fault tolerant control scheme

a priori but available at real-time. The same assumption is made in the present paper where the premise variable $\xi(t)$ is supposed to be measurable.

The weighting functions satisfy the following convex sum property:

$$\sum_{i=1}^r \mu_i(\xi(t)) = 1, \quad 0 \leq \mu_i(\xi(t)) \leq 1, \quad \forall t, \forall i = 1, \dots, r \quad (5)$$

This property allows the generalization of the tools developed for linear systems to nonlinear systems.

3. FAULT TOLERANT CONTROLLER DESIGN FOR T-S SYSTEMS

3.1. Outline of the proposed approach

The proposed fault tolerant control strategy is described in the figure 1. The residual generator aims at detecting and isolating each sensor fault based on a dedicated residual signal. Each of the p observers is designed to estimate the state vector of the system from one of the p outputs. Hence, if a given sensor is faulty, the estimated state provided by the corresponding observer is corrupted but the others are healthy. The controller is the well known observer-based one but the used estimated state is obtained from a weighted sum of the estimated states provided by each observer. The weighting functions that weight each state vector are designed in such a way to satisfy the convex sum property and the continuity to avoid the switching phenomenon. These functions depend on the residual vector. If a given sensor is faulty then the corresponding weighting function goes to zero and only healthy estimated states are used in the closed-loop feedback, then the sensor fault does not affect the nominal operating of the closed-loop system. In the following sections, the design of such fault tolerant controller is detailed.

3.2. Residual generator for sensor fault detection and isolation

The robust residual generator design is based on the same framework as [23]. The gains of the residual generator are determined in order to minimize the \mathcal{L}_2 gain of the transfer from the disturbance vector $\nu(t) = [d^T(t) \quad f^T(t)]^T$ to the fault estimation error $r_e(t) = r(t) - f(t)$. As a consequence, the obtained residual $r(t)$ is an estimation of the fault, achieving both its detection and isolation.

Based on the model (4), the following residual generator is then proposed

$$\begin{cases} \dot{\hat{x}}(t) = \sum_{i=1}^r \mu_i(\xi(t)) (A_i \hat{x}(t) + B_i u(t) + L_i (y(t) - \hat{y}(t))) \\ \hat{y}(t) = \sum_{i=1}^r \mu_i(\xi(t)) C_i \hat{x}(t) \\ r(t) = M(y(t) - \hat{y}(t)) \end{cases} \quad (6)$$

This residual generator is designed for providing a residual vector $r(t)$ such that its i^{th} component is only sensitive to the i^{th} sensor fault (residual structuration). The gain matrices M and L_i of the residual generator satisfying the specifications of sensor fault estimation and perturbation attenuation are determined by solving the optimization problem given in the theorem 1.

Theorem 1

The robust residual generator (6) exists if there exists a symmetric and positive definite matrix $P = P^T > 0$, matrices \bar{L}_i and M , and a positive scalar γ , solution to the following optimization problem

$$\min_{P, \bar{L}_i, M} \gamma \quad (7)$$

under the following LMI constraints

$$\begin{cases} X_{ii} < 0, & i = 1, \dots, r \\ \frac{2}{r-1} X_{ii} + X_{ij} + X_{ji} < 0, & i, j = 1, \dots, r, i \neq j \end{cases} \quad (8)$$

where X_{ij} , for $(i, j) \in \{1, \dots, r\}$, are defined by

$$X_{ij} = \begin{pmatrix} A_i^T P + P A_i - \bar{L}_i C_j - C_j^T \bar{L}_i^T & P E_i - \bar{L}_i G_j & -\bar{L}_i & C_j^T M^T \\ E_i^T P - G_j^T \bar{L}_i^T & -\gamma I & 0 & G_j^T M^T \\ -\bar{L}_i^T & 0 & -\gamma I & M^T - I \\ M C_j & M G_i & M - I & -\gamma I \end{pmatrix} \quad (9)$$

The residual generator gains are given by $L_i = P^{-1} \bar{L}_i$ and M . The attenuation level from $\nu(t)$ to the fault estimation error $r_e(t)$ is given by γ .

Proof

The LMI (9) are obtained using the well-known Bounded Real Lemma and the Tuan's relaxation. The proof is omitted but the reader can refer to [23, 24] where that residual generator is studied in details. \square

3.3. Sensor fault tolerant control design

After generating the residual vector $r(t)$ that estimates the sensor faults, the objective is now to use it in order to actively reconfigure the control law by eliminating (or at least minimizing) the fault effect on the system. This section describes the three steps in designing the fault tolerant controller: the first step concerns the design of an observer bank that estimates the state vector from each output separately, the second step concerns the choice of the structure of the controller that uses a new estimated state vector derived from the weighted estimated state vectors obtained at the first step. Finally, the third step is devoted to the stability analysis of the closed loop system with the observer-based controller and LMI conditions are established for design purpose.

Firstly, an observer bank is designed. The k^{th} observer is fed with the control input vector $u(t)$ and the k^{th} system output $y^k(t)$ as illustrated in the figure 1. If a fault occurs on a sensor different of the k^{th} one, the observer using this k^{th} output provides a fault-free state vector estimation.

The k^{th} observer ($k = 1, \dots, p$) has the following form:

$$\begin{cases} \dot{\hat{x}}^k(t) = \sum_{i=1}^r \mu_i(\xi(t)) (A_i \hat{x}^k(t) + B_i u(t) + L_i^k (y^k(t) - \hat{y}^k(t))) \\ \hat{y}^k(t) = \sum_{i=1}^r \mu_i(\xi(t)) C_i^k \hat{x}^k(t) \end{cases} \quad (10)$$

where C_i^k is the k^{th} row of the matrix C_i corresponding to the k^{th} sensor and $y^k(t)$ represents the k^{th} entry of the $y(t)$ vector. The k^{th} observer provides the estimated state vector $\hat{x}^k(t)$ based on the knowledge of the input and the k^{th} output. The different state estimates $\hat{x}^k(t)$, $k = 1, \dots, p$ are then blended to build a representative state estimation vector $\hat{x}^b(t)$ according to:

$$\hat{x}^b(t) = \sum_{k=1}^p h_k(r(t)) \hat{x}^k(t) \quad (11)$$

The blending is ensured by the weighting nonlinear functions $h_k(r(t))$ depending on the residual vector $r(t)$ (6). These functions satisfy the smoothness and the convex sum property which allow the derivation of LMI design conditions in the next. The design of such functions is based on the idea that if the k^{th} sensor is faulty, the k^{th} component of the residual vector, namely $r_k(t)$, deviates from zero. Consequently, the corresponding weighting function $h_k(r(t))$ has to converge to zero in order to decouple the state estimate $\hat{x}^b(t)$ from the fault acting on the k^{th} sensor. Hence, $\hat{x}^b(t)$ is turned to a convex weighted sum of the estimated states except the k^{th} one. The effect of the fault is then minimized. Different structures of the weighting functions h_k can be proposed. In this paper, the chosen weighting functions h_k , for $k = 1, \dots, p$ are defined by:

$$\omega_k(r_k(t)) = \exp(-r_k^2(t)/\sigma_k) \quad (12a)$$

$$h_k(r(t)) = \frac{\omega_k(r_k(t))}{\sum_{\ell=1}^p \omega_\ell(r_\ell(t))} \quad (12b)$$

where the parameters σ_k are used to take into account the spreading around zero of r_k , the k^{th} component of the residual vector $r(t)$. The Gaussian weight function (12a) exponentially decreases to zero when r_k deviates from zero. Equation (12b) ensures the normalization of the different functions such that the convex sum property (5) holds.

The second step deals with the choice of the control law. Here, the proposed control law is a classical observer-based PDC control law, but the estimated state vector (given by one observer in the classical version of this structure) is replaced by the weighted state vector $\hat{x}_b(t)$ which is fault-free. The control law is then given by:

$$u(t) = -\sum_{j=1}^r \mu_j(\xi(t)) K_j \hat{x}^b(t) \quad (13)$$

Contrarily to [19], where the stability of the closed loop system with the switching mechanism between the different dedicated controllers is not guaranteed, the proposed approach aims at the stabilization of the closed loop system, including the controller bank and the weighting strategy.

In the third step, the stability of the closed-loop system is studied using classical approaches developed for T-S models. The k^{th} state estimation error $e^k(t) = x(t) - \hat{x}^k(t)$ is generated by the following differential equation, obtained from (4) and (10):

$$\dot{e}^k(t) = \sum_{i=1}^r \sum_{j=1}^r \mu_i(\xi(t)) \mu_j(\xi(t)) ((A_i - L_i^k C_j^k) e^k(t) + (E_i - L_i^k G_j) d(t) - L_i^k f(t)) \quad (14)$$

The closed-loop system is then described by the following equations (obtained from equations (4) and (13))

$$\dot{x}(t) = \sum_{i=1}^r \sum_{j=1}^r \sum_{k=1}^p h_k(r(t)) \mu_i(\xi(t)) \mu_j(\xi(t)) (A_i x(t) - B_i K_j \hat{x}^k(t) + E_i d(t)) \quad (15)$$

$$= \sum_{i=1}^r \sum_{j=1}^r \sum_{k=1}^p h_k(r(t)) \mu_i(\xi(t)) \mu_j(\xi(t)) ((A_i - B_i K_j) x(t) + B_i K_j e^k(t) + E_i d(t)) \quad (16)$$

and

$$\tilde{\Xi}_{ij} = QA_i^T + A_iQ - B_iF_j - F_j^T B_i^T \quad (26)$$

$$\mathcal{M}_{ij} = \text{diag}(\Omega_{ij}^1, \dots, \Omega_{ij}^p) \quad (27)$$

$$\Omega_{ij}^k = A_i^T P_k + P_k A_i - M_i^k C_j^k - (M_i^k C_j^k)^T + (\lambda_k + 1)I, \quad k = 1, \dots, p \quad (28)$$

$$\tilde{R}_{ij} = \left(\underbrace{B_i F_j \quad \dots \quad B_i F_j}_{p \text{ terms}} \right) \quad (29)$$

$$\tilde{S}_{ij}^T = \left((E_i - M_i^1 G_j)^T \quad \dots \quad (E_i - M_i^p G_j)^T \right) \quad (30)$$

$$\tilde{\tilde{S}}_{ij}^T = \left(-(M_i^1)^T \quad \dots \quad -(M_i^p)^T \right) \quad (31)$$

$$\tilde{\Lambda} = \text{diag}(\lambda_1 I_n, \dots, \lambda_p I_n) \quad (32)$$

$$\tilde{Q} = \text{diag}(\underbrace{Q, \dots, Q}_{p \text{ terms}}) \quad (33)$$

The gains of the controller and the observers are derived from $K_i = F_i Q^{-1}$ and $L_i^k = P_k^{-1} M_i^k$. The transfer from $\nu(t)$ to $x_a(t)$ is quantified by the gain $\eta = \sqrt{\bar{\eta}}$.

Proof

It is well known that the \mathcal{L}_2 -gain from $\nu(t)$ to $x_a(t)$ is bounded by η if there exists a Lyapunov function satisfying [25]

$$\dot{V}(x_a(t)) + x_a^T(t)x_a(t) - \eta^2 \nu^T(t)\nu(t) < 0 \quad (34)$$

Consider the quadratic Lyapunov function $V(x_a(t)) = x_a^T(t)P x_a(t)$ where $P = P^T > 0$ is given by the diagonal structure $P = \text{diag}(X, \tilde{P})$, with $\tilde{P} = \text{diag}(P_1, \dots, P_p)$. With (18), the inequality (34) becomes

$$x_a^T(\mathcal{A}_{\mu\mu}^T P + P \mathcal{A}_{\mu\mu} + \Delta \mathcal{A}_{\mu\mu}^T(t)P + P \Delta \mathcal{A}_{\mu\mu}(t) + I_n) x_a(t) + 2x_a^T(t)P \mathcal{E}_{\mu\mu} \nu(t) - \eta^2 \nu^T(t)\nu(t) < 0 \quad (35)$$

The time varying matrices $\Delta \mathcal{A}_{ij}(t)$ in (35) can be written as $\Delta \mathcal{A}_{ij}(t) = \mathcal{K}_{ij} \Sigma(t)$ with

$$\Sigma(t) = \text{diag}(0_n, h_1(r(t)), \dots, h_p(r(t))) \quad \text{and} \quad \mathcal{K}_{ij} = \begin{pmatrix} 0 & B_i K_j & \dots & B_i K_j \\ 0 & 0 & \ddots & \vdots \\ \vdots & \vdots & \ddots & 0 \\ 0 & \dots & 0 & 0 \end{pmatrix} \quad (36)$$

Recalling that the functions $h_k(r(t))$ satisfy the convex sum property (5), it follows that

$$\Sigma^T(t)\Sigma(t) \leq \text{diag}(0_n, I_{np}) \quad (37)$$

Using the lemma 1, the term $x_a^T(t)(\Delta \mathcal{A}_{\mu\mu}^T(t)P + P \Delta \mathcal{A}_{\mu\mu}(t))x_a(t)$ in (35) can be bounded as follows

$$x_a^T(t) (\Delta \mathcal{A}_{\mu\mu}^T(t)P + P \Delta \mathcal{A}_{\mu\mu}(t)) x_a(t) \leq x_a^T(t) (\Sigma^T(t)\Lambda\Sigma(t) + P \mathcal{K}_{\mu\mu} \Lambda^{-1} \mathcal{K}_{\mu\mu}^T P) x_a(t) \quad (38)$$

where $\Lambda = \text{diag}(\varepsilon I_n, \lambda_1 I_n, \dots, \lambda_p I_n)$, with $\varepsilon, \lambda_1, \dots, \lambda_p > 0$, is a diagonal positive definite matrix. The term $\Sigma^T \Lambda \Sigma$ can be bounded by using the inequality (37), this leads to $\Sigma^T \Lambda \Sigma \leq \bar{\Lambda}$ where $\bar{\Lambda} = \text{diag}(0, \lambda_1 I_n, \dots, \lambda_p I_n)$ and it follows

$$x_a^T(t) (\Delta \mathcal{A}_{\mu\mu}^T(t)P + P \Delta \mathcal{A}_{\mu\mu}(t)) x_a(t) \leq x_a^T(t) (\bar{\Lambda} + P \mathcal{K}_{\mu\mu} \Lambda^{-1} \mathcal{K}_{\mu\mu}^T P) x_a(t) \quad (39)$$

Considering the augmented vector $\tilde{x}(t) = (x_a^T(t) \nu^T(t))^T$, with (39), the inequality (35) is satisfied if the following inequality holds

$$\begin{pmatrix} \mathcal{A}_{\mu\mu}^T P + P \mathcal{A}_{\mu\mu} + \bar{\Lambda} + P \mathcal{K}_{\mu\mu} \Lambda^{-1} \mathcal{K}_{\mu\mu}^T P + I & P \mathcal{E}_{\mu\mu} \\ \mathcal{E}_{\mu\mu}^T P & -\eta^2 I \end{pmatrix} < 0 \quad (40)$$

Applying the Schur complement Lemma [25], the inequality (40) is equivalent to

$$\begin{pmatrix} \mathcal{A}_{\mu\mu}^T P + P \mathcal{A}_{\mu\mu} + \bar{\Lambda} + I & P \mathcal{K}_{\mu\mu} & P \mathcal{E}_{\mu\mu} \\ \mathcal{K}_{\mu\mu}^T P & -\Lambda & 0 \\ \mathcal{E}_{\mu\mu}^T P & 0 & -\eta^2 I \end{pmatrix} < 0 \quad (41)$$

Keeping in mind that $P = \text{diag}(X, \tilde{P})$ with $\tilde{P} = \text{diag}(P_1, \dots, P_p)$, the inequality (41) can be detailed as

$$\begin{pmatrix} \Xi_{\mu\mu} & 0 & 0 & X R_{\mu\mu} & X E_{\mu} & 0 \\ 0 & \mathcal{M}_{\mu\mu} & 0 & 0 & \tilde{P} S_{\mu\mu} & \tilde{P} \tilde{S}_{\mu\mu} \\ 0 & 0 & -\varepsilon I_n & 0 & 0 & 0 \\ R_{\mu\mu}^T X & 0 & 0 & -\tilde{\Lambda} & 0 & 0 \\ E_{\mu}^T X & S_{\mu\mu}^T \tilde{P} & 0 & 0 & -\eta^2 I_{n_d} & 0 \\ 0 & \tilde{S}_{\mu\mu}^T \tilde{P} & 0 & 0 & 0 & -\eta^2 I_p \end{pmatrix} < 0 \quad (42)$$

where $\tilde{\Lambda} = \text{diag}(\lambda_1 I_n, \dots, \lambda_p I_n)$ and

$$\Xi_{\mu\mu} = A_{\mu}^T X + X A_{\mu} - X B_{\mu} K_{\mu} - K_{\mu}^T B_{\mu}^T X + I \quad (43)$$

$$\mathcal{M}_{\mu\mu} = \text{diag}(\Omega_{\mu\mu}^1, \dots, \Omega_{\mu\mu}^p) \quad (44)$$

$$\Omega_{\mu\mu}^k = A_{\mu}^T P_k + P_k A_{\mu} - P_k L_{\mu}^k C_{\mu}^k - (P_k L_{\mu}^k C_{\mu}^k)^T + (\lambda_k + 1) I \quad (45)$$

$$R_{\mu\mu} = \begin{pmatrix} B_{\mu} K_{\mu} & \cdots & B_{\mu} K_{\mu} \\ \underbrace{\hspace{10em}}_{p \text{ terms}} \end{pmatrix} \quad (46)$$

$$S_{\mu\mu}^T = \begin{pmatrix} (E_{\mu} - L_{\mu}^1 G_{\mu})^T & \cdots & (E_{\mu} - L_{\mu}^p G_{\mu})^T \end{pmatrix} \quad (47)$$

$$\tilde{S}_{\mu\mu}^T = \begin{pmatrix} (-L_{\mu}^1)^T & \cdots & (-L_{\mu}^p)^T \end{pmatrix} \quad (48)$$

The inequality (42) is a sufficient condition for a bounded \mathcal{L}_2 -gain from $\nu(t)$ to $x_a(t)$. Unfortunately, it is not linear in the unknown matrices and it is time varying because of the weighting functions $\mu_i(\cdot)$. In the remaining of the proof, sufficient LMI conditions are derived. Let us define the matrix W by

$$W = \text{diag}(Q, I_{np}, I_n, \tilde{Q}, I_{n_d}, I_p)$$

where $Q = X^{-1}$ and $\tilde{Q} = \text{diag}(Q, \dots, Q)$. In order to obtain LMI, let us define $\eta^2 = \bar{\eta}$ and apply

the congruence lemma 2 to (42) by pre and post multiplying by W , it follows

$$\begin{pmatrix} Q \Xi_{\mu\mu} Q & 0 & 0 & R_{\mu\mu} \tilde{Q} & E_{\mu} & 0 \\ 0 & \mathcal{M}_{\mu\mu} & 0 & 0 & \tilde{P} S_{\mu\mu} & \tilde{P} \tilde{S}_{\mu\mu} \\ 0 & 0 & -\varepsilon I_n & 0 & 0 & 0 \\ \tilde{Q} R_{\mu\mu}^T & 0 & 0 & -\tilde{Q} \tilde{\Lambda} \tilde{Q} & 0 & 0 \\ E_{\mu}^T & S_{\mu\mu}^T \tilde{P} & 0 & 0 & -\bar{\eta} I_{n_d} & 0 \\ 0 & \tilde{S}_{\mu\mu}^T \tilde{P} & 0 & 0 & 0 & -\bar{\eta} I_p \end{pmatrix} < 0 \quad (49)$$

By using the lemma 3 on the matrix block $-\tilde{Q}\tilde{\Lambda}\tilde{Q}$ as well as a Schur complement, inequality (49) is implied by $\mathcal{H}_{\mu\mu} < 0$ with

$$\mathcal{H}_{\mu\mu} = \begin{pmatrix} Q\Xi_{\mu\mu}Q & 0 & 0 & R_{\mu\mu}\tilde{Q} & E_{\mu} & 0 & 0 \\ 0 & \mathcal{M}_{\mu\mu} & 0 & 0 & \tilde{P}S_{\mu\mu} & \tilde{P}\tilde{S}_{\mu\mu} & 0 \\ 0 & 0 & -\varepsilon I_n & 0 & 0 & 0 & 0 \\ \tilde{Q}R_{\mu\mu}^T & 0 & 0 & -2\beta\tilde{Q} & 0 & 0 & \beta I \\ E_{\mu}^T & S_{\mu\mu}^T\tilde{P} & 0 & 0 & -\bar{\eta}I_{n_d} & 0 & 0 \\ 0 & \tilde{S}_{\mu\mu}^T\tilde{P} & 0 & 0 & 0 & -\bar{\eta}I_p & 0 \\ 0 & 0 & 0 & \beta I & 0 & 0 & -\tilde{\Lambda} \end{pmatrix} \quad (50)$$

where β is a positive scalar. Consequently, if the inequality $\mathcal{H}_{\mu\mu} < 0$ holds, then inequality (35) holds too. Due to the convex sum property of the weighting functions, an obvious but conservative set of sufficient conditions is given by $\mathcal{H}_{ij} < 0$ (for $i, j = 1, \dots, r$). The conservativeness is considerably reduced by applying the result proposed by Tuan in [10]: the sufficient conditions are the following

$$\begin{cases} \mathcal{H}_{ii} < 0, & i = 1, \dots, r \\ \frac{2}{r-1}\mathcal{H}_{ii} + \mathcal{H}_{ij} + \mathcal{H}_{ji} < 0, & i, j = 1, \dots, r, i \neq j \end{cases} \quad (51)$$

where \mathcal{H}_{ij} is defined by

$$\mathcal{H}_{ij} = \begin{pmatrix} Q\Xi_{ij}Q & 0 & 0 & R_{ij}\tilde{Q} & E_i & 0 & 0 \\ 0 & \mathcal{M}_{ij} & 0 & 0 & \tilde{P}S_{ij} & \tilde{P}\tilde{S}_{ij} & 0 \\ 0 & 0 & -\varepsilon I_n & 0 & 0 & 0 & 0 \\ \tilde{Q}R_{ij}^T & 0 & 0 & -2\beta\tilde{Q} & 0 & 0 & \beta I \\ E_i^T & S_{ij}^T\tilde{P} & 0 & 0 & -\bar{\eta}I_{n_d} & 0 & 0 \\ 0 & \tilde{S}_{ij}^T\tilde{P} & 0 & 0 & 0 & -\bar{\eta}I_p & 0 \\ 0 & 0 & 0 & \beta I & 0 & 0 & -\tilde{\Lambda} \end{pmatrix} \quad (52)$$

The variable changes $F_j = K_jQ$ and $M_i^k = P_kL_i^k$ are used and a Schur complement on the term QQ in the (1, 1) block is performed to obtain the LMI conditions of the theorem 2, which ends the proof. \square

Tuan's Lemma [10] has been considered in the previous section to relax the stability conditions of the proposed sensor fault tolerant observer based controller. Obviously, there exists many other relaxation techniques. Particularly, the quadratic Lyapunov function can be replaced by a non-quadratic one. Here is only mentioned an interesting approach, described in [11], where the authors have provided asymptotic necessary and sufficient conditions for the negativity of the double sum inequality $\tilde{x}(t)^T Y_{\mu\mu} \tilde{x}(t) < 0$. In the following, the Polya's theorem is recalled (as given in [11]) and applied to the proposed result in the theorem 2. Knowing that

$$\left(\sum_{i=1}^r \mu_i(\xi(t)) \right)^q = 1 \quad (53)$$

where q is a positive integer, the inequality (50) is equivalent to

$$\left(\sum_{i=1}^r \mu_i(\xi(t)) \right)^q \mathcal{H}_{\mu\mu} < 0 \quad (54)$$

By developing (54) with respect to the weighting functions, relaxed LMI conditions are obtained. Furthermore, if $q \rightarrow \infty$, asymptotic necessary and sufficient conditions are obtained [11]. For example, assuming $q = 1$ the LMI constraints (24) are replaced by

$$\begin{cases} \mathcal{H}_{ii} < 0, & i = 1, \dots, r \\ \mathcal{H}_{ii} + \mathcal{H}_{ij} + \mathcal{H}_{ji} < 0, & i, j = 1, \dots, r, i \neq j \end{cases} \quad (55)$$

The LMIs (55) are clearly less conservative than the Tuan's ones. Of course when q increases, the number of LMIs increases too but the number of variables remains the same (there is no additional slack variables).

3.4. Fault tolerant control design algorithm

The design of the proposed sensor fault tolerant controller can be summarized as follows.

1. Compute the gains of the residual generator by solving the optimization problem under LMI constraints given by (8).
2. Compute the gains of the FT controller by solving the optimization problem under LMI constraints given by (24).
3. Implement the residual generator (6) that provides $r(t)$ and the weighting functions (12).
4. Implement the observers (10), compute the blended state estimation (11) and finally the FT controller (13).

Remark 1

It is important to point out that the use of the Dedicated Observer Structure (DOS) in the FTC block requires the observability of each pair (A_i, C_j^k) which is not always satisfied. A solution to overcome such a problem is to use the Generalized Observer Structure (GOS). Consequently, before designing the FTC strategy, it is necessary to check the observability of the system state from each output separately. If the state is not observable from a set of outputs, the GOS structure may be suitable. Doing so, it is possible to identify the sensor set with possible fault compensation before designing the FTC.

4. AN ALTERNATIVE APPROACH

The proposed approach consists in designing a bank of observers to construct a weighted state vector which is used by a PDC controller. In this section, a slight modification of the previous controller structure is briefly considered. This FTC strategy is different in the sense that a bank of observer-based controllers is designed as in classical point of view and each control signal is associated to a weighting function depending on the residual signal. Then, if a fault occurs in the k^{th} sensor, the corresponding control signal $u^k(t)$ is disabled by forcing the weighting function $h_k(r(t))$ to zero. The applied control signal to the system is then expressed by

$$u^b(t) = \sum_{k=1}^p h_k(r(t)) u^k(t) \quad (56)$$

This approach is illustrated in the figure 2 which can be compared to those of figure 1. The equations related to this new structure are

$$RG : \begin{cases} \dot{\hat{x}}(t) = \sum_{i=1}^r \mu_i(\xi(t)) (A_i \hat{x}(t) + B_i u^b(t) + L_i (y(t) - \hat{y}(t))) \\ \hat{y}(t) = C \hat{x}(t) \\ r(t) = M (y(t) - \hat{y}(t)) \end{cases} \quad (57)$$

and

$$FTC : \begin{cases} \dot{\hat{x}}^k(t) = \sum_{i=1}^r \mu_i(\xi(t)) (A_i \hat{x}^k(t) + B_i u^b(t) + L_i^k (y^k(t) - \hat{y}^k(t))) \\ \hat{y}^k(t) = C^k \hat{x}^k(t) \\ u^k(t) = - \sum_{i=1}^r \mu_i(\xi(t)) K_i^k \hat{x}^k(t) \\ u^b(t) = \sum_{k=1}^p h_k(r(t)) u^k(t) \end{cases} \quad (58)$$

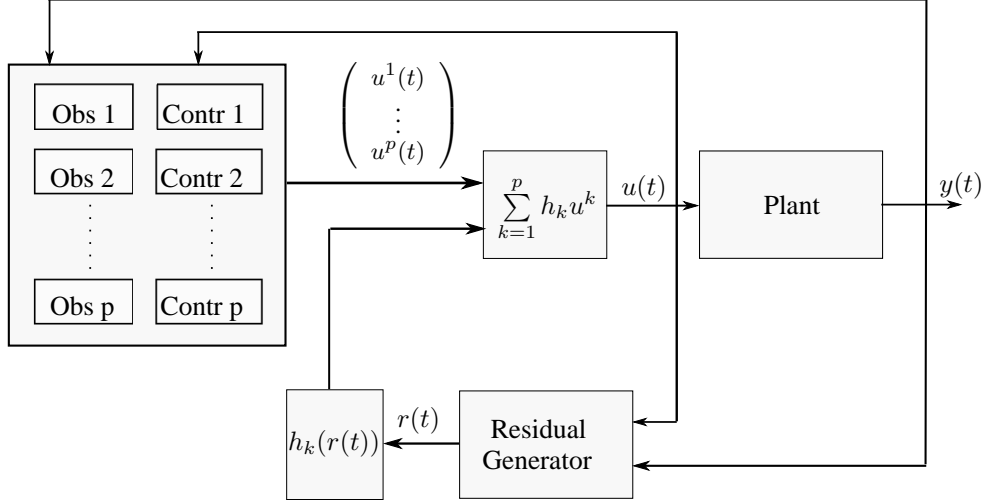

Figure 2. Sensor fault tolerant control scheme 2

The residual generator RG and the weighting functions $h_i(r(t))$ are designed in the same manner as in the first approach. The closed-loop system is then described by the following equation:

$$\dot{x}(t) = \sum_{i=1}^r \sum_{j=1}^r \sum_{k=1}^p \mu_i(\xi(t)) \mu_j(\xi(t)) h_k(r(t)) (A_i x(t) - B_i K_j^k \hat{x}^k(t) + E_i d(t)) \quad (59)$$

$$= \sum_{i=1}^r \sum_{j=1}^r \sum_{k=1}^p \mu_i(\xi(t)) \mu_j(\xi(t)) h_k(r(t)) ((A_i - B_i K_j^k) x(t) + B_i K_j^k e^k(t) + E_i d(t)) \quad (60)$$

The equation (60) is similar to the equation (16) of the first approach where the matrices K_j of the controller are simply replaced by K_j^k . Therefore, stability conditions expressed in terms of LMI can be established using the same reasoning.

5. VEHICLE LATERAL DYNAMICS SENSOR FTC

In this section, some simulations are provided to illustrate the proposed FTC approach. The lateral dynamics control of a vehicle in the presence of sensor faults is considered. Firstly, a T-S model is established from the model of the vehicle lateral dynamics by considering the longitudinal velocity v_x as time-varying. Secondly, a residual generator is constructed and validated with real data measurements. Finally, the FTC controller is designed and simulated with real data affected by simulated faults.

5.1. Vehicle lateral dynamics model

To illustrate the proposed approach and the design of the sensor fault tolerant controller, let us consider the lateral dynamics model described by the following equations

$$\begin{cases} \dot{v}_y(t) = \frac{1}{m} (F_{yf}(t) + F_{yr}(t)) - v_x(t) \dot{\psi}(t) \\ \dot{\psi}(t) = \frac{1}{I_z} (a_f F_{yf}(t) - a_r F_{yr}(t)) + \frac{1}{I_z} u(t) \end{cases} \quad (61)$$

where $v_y(t)$ and $\dot{\psi}(t)$ denote, respectively, the lateral velocity and the yaw rate, $F_{yf}(t)$ and $F_{yr}(t)$ are the lateral forces acting, respectively, on the front and rear wheels. The parameter a_f (resp. a_r) represent the distance from the front (resp. rear) wheel to the center of gravity. I_z is the yaw moment of inertia, m is the total mass of the vehicle and $v_x(t)$ is the longitudinal velocity. The control input is defined by $u(t)$ which represents a force moment generated by differential braking

on the vehicle rear wheels. This control input aims at stabilizing the yaw motion. All the variables and the parameters are summarized in the table I

Time varying variables	
$\dot{\psi}$	yaw rate
v_x, v_y	longitudinal and lateral velocities
F_f^S, F_r^S	steady-state front and rear steady state lateral efforts
F_f, F_r	front and rear lateral efforts
Constant parameters	
r_f, r_r	relaxation length of the front and rear tires
m, I_z	mass of the vehicle and the yaw moment
a_f, a_r	distances from the front and rear axle to the center of gravity
B_i, C_i, D_i and $E_i, i = \{f, r\}$	characteristic matrices of the tires in the Pacejka's model

Table I. Table of variables and parameters

Due to the characteristics of the tires, it is generally assumed that the forces $F_{yf}(t)$ and $F_{yr}(t)$ are generated by dynamical systems described by

$$\begin{cases} \frac{r_f}{v_x} \dot{F}_{yf}(t) + F_{yf}(t) = F_{yf}^S(t) \\ \frac{r_r}{v_x} \dot{F}_{yr}(t) + F_{yr}(t) = F_{yr}^S(t) \end{cases} \quad (62)$$

which takes into account the transient phase of the tires response. Where $r_i, i \in \{r, f\}$ are the relaxation lengths which are positive scalars. The inputs $F_{yf}^S(t)$ and $F_{yr}^S(t)$ are the steady-state (static) forces expressed by the ‘‘magic formula’’ of Pacejka [26].

$$F_{yi}^S(t) = D_i \sin \left(C_i \tan^{-1} \left(B_i (1 - E_i) \alpha_i(t) + E_i \tan^{-1} (B_i \alpha_i(t)) \right) \right), \quad i \in \{f, r\} \quad (63)$$

where B_i, C_i, D_i and E_i are parameters depending on the characteristics of the tires and the road. $\alpha_f(t)$ and $\alpha_r(t)$ represent the tire slip angles of the front and the rear wheels respectively which are expressed by

$$\begin{cases} \alpha_f(t) = -\frac{v_y(t)}{v_x(t)} - \tan^{-1} \left(\frac{a_f}{v_x(t)} \dot{\psi}(t) \cos \left(\frac{v_y(t)}{v_x(t)} \right) \right) + \delta_f(t) \\ \alpha_r(t) = -\frac{v_y(t)}{v_x(t)} + \tan^{-1} \left(\frac{a_r}{v_x(t)} \dot{\psi}(t) \cos \left(\frac{v_y(t)}{v_x(t)} \right) \right) \end{cases} \quad (64)$$

where $\delta_f(t)$ is the front steering angle. The body sideslip angle is defined by $\beta(t) = \tan^{-1} \left(\frac{v_y(t)}{v_x(t)} \right)$. In normal driving situations, the lateral velocity is small which allows to approximate the sideslip angle by $\beta \approx \frac{v_y(t)}{v_x(t)}$; this angle is also small in this driving mode. Consequently, the wheel sideslip angles $\alpha_f(t)$ and $\alpha_r(t)$ do not exceed 8 degrees, therefore, the equation (64) can be simplified as follows

$$\begin{cases} \alpha_f(t) = -\frac{v_y(t)}{v_x(t)} - \frac{a_f}{v_x(t)} \dot{\psi}(t) + \delta_f(t) \\ \alpha_r(t) = -\frac{v_y(t)}{v_x(t)} + \frac{a_r}{v_x(t)} \dot{\psi}(t) \end{cases} \quad (65)$$

Consequently, the forces $F_{yf}^S(\alpha_f(t))$ and $F_{yr}^S(\alpha_r(t))$ are in the linear zone which can be expressed by the linear expressions

$$\begin{cases} F_{yf}^S(t) = C_f \left(-\frac{v_y(t)}{v_x(t)} - \frac{a_f}{v_x(t)} \dot{\psi}(t) + \delta_f(t) \right) \\ F_{yr}^S(t) = C_r \left(-\frac{v_y(t)}{v_x(t)} + \frac{a_r}{v_x(t)} \dot{\psi}(t) \right) \end{cases} \quad (66)$$

where $C_f = D_f C_f B_f$ and $C_r = D_r C_r B_r$. By using the following change of coordinates

$$\begin{cases} x_1(t) = v_y(t) \\ x_2(t) = \dot{\psi}(t) \\ x_3(t) = \frac{1}{m} (F_{yf}(t) + F_{yr}(t)) \\ x_4(t) = \frac{1}{I_z} (a_f F_{yf}(t) - a_r F_{yr}(t)) \end{cases} \quad (67)$$

the following dynamical system is obtained

$$\begin{cases} \dot{x}_1(t) = -v_x(t)x_2(t) + x_3(t) \\ \dot{x}_2(t) = x_4(t) + \frac{1}{I_z}u(t) \\ \dot{x}_3(t) = -\frac{v_x(t)}{r}x_3(t) + \frac{v_x(t)}{mr}(F_{yf}^S(t) + F_{yr}^S(t)) \\ \dot{x}_4(t) = -\frac{v_x(t)}{r}x_4(t) + \frac{v_x(t)}{I_z r}(a_f F_{yf}^S(t) - a_r F_{yr}^S(t)) \end{cases} \quad (68)$$

The change of variables aims at scaling the state variables and the matrices in order to reduce the conservatism related to the LMI constraints. Note also that the relaxation terms r_f and r_r are considered identical and denoted by r . By assuming that the longitudinal velocity is time-varying, which is more realistic than a constant one as commonly used in the literature, and by expressing the system in matrix formulation, one obtains

$$\dot{x}(t) = A(v_x(t))x(t) + B_{\delta_f}(v_x(t))\delta_f(t) + Bu(t) \quad (69)$$

where $u(t)$ is the control input and $\delta_f(t)$ is known (can thus be provided to the residual generator and observers) but not controllable (and thus cannot be set by the controller) and where

$$A(v_x(t)) = \begin{pmatrix} 0 & -v_x(t) & 1 & 0 \\ 0 & 0 & 0 & 1 \\ a_{31} & a_{32} & a_{33}v_x(t) & 0 \\ a_{41} & a_{42} & 0 & a_{44}v_x(t) \end{pmatrix}, \quad B_{\delta_f}(v_x(t)) = \begin{pmatrix} 0 \\ 0 \\ b_3v_x(t) \\ b_4v_x(t) \end{pmatrix}, \quad B = \begin{pmatrix} 0 \\ \frac{1}{I_z} \\ 0 \\ 0 \end{pmatrix}$$

and

$$\begin{aligned} a_{31} &= -\frac{C_f}{mr} - \frac{C_r}{mr}, & a_{32} &= \frac{C_r a_r}{mr} - \frac{C_f a_f}{mr} \\ a_{33} &= a_{44} = -\frac{1}{r}, & a_{41} &= \frac{a_r C_r}{I_z r} - \frac{a_f C_f}{I_z r} \\ a_{42} &= -\frac{a_f^2 C_f}{I_z r} - \frac{C_r a_r^2}{I_z r} \\ b_3 &= \frac{C_f}{mr}, & b_4 &= \frac{a_f C_f}{I_z r} \end{aligned}$$

Assuming that the vehicle longitudinal velocity is bounded as follows $0 < v_{\min} \leq v_x(t) \leq v_{\max} < +\infty$, and using the sector nonlinearity approach [1], the following T-S model is obtained

$$\dot{x}(t) = \sum_{i=1}^2 \mu_i(v_x(t)) (A_i x(t) + B_{i\delta_f} \delta_f + Bu(t)) \quad (70)$$

where the activating functions are defined by

$$\mu_1(v_x(t)) = \frac{v_x(t) - v_{\min}}{v_{\max} - v_{\min}}, \quad \mu_2(v_x(t)) = \frac{v_{\max} - v_x(t)}{v_{\max} - v_{\min}}$$

and the sub-model matrices are given by

$$\begin{aligned} A_1 &= \begin{pmatrix} 0 & -v_{\max} & 1 & 0 \\ 0 & 0 & 0 & 1 \\ a_{31} & a_{32} & a_{33}v_{\max} & 0 \\ a_{41} & a_{42} & 0 & a_{44}v_{\max} \end{pmatrix}, & B_{1\delta_f} &= \begin{pmatrix} 0 \\ 0 \\ b_3v_{\max} \\ b_4v_{\max} \end{pmatrix} \\ A_2 &= \begin{pmatrix} 0 & -v_{\min} & 1 & 0 \\ 0 & 0 & 0 & 1 \\ a_{31} & a_{32} & a_{33}v_{\min} & 0 \\ a_{41} & a_{42} & 0 & a_{44}v_{\min} \end{pmatrix}, & B_{2\delta_f} &= \begin{pmatrix} 0 \\ 0 \\ b_3v_{\min} \\ b_4v_{\min} \end{pmatrix} \end{aligned}$$

The vehicle is equipped by sensors providing the measurement of the yaw rate $\dot{\psi}(t)$ and the lateral acceleration a_y . Since $a_y = \frac{1}{m}(F_{yf}(t) + F_{yr}(t)) - v_x(t)\dot{\psi}(t) = x_3(t) - v_x(t)x_2(t)$. Taking into account the additive sensor fault $f(t)$ possibly affecting each sensor, the output equation is

defined as follows

$$y(t) = \sum_{i=1}^2 \mu_i(v_x(t)) C_i x(t) + f(t) \quad (71)$$

where

$$C_1 = \begin{pmatrix} 0 & 1 & 0 & 0 \\ 0 & -v_{\max} & 1 & 0 \end{pmatrix}, \quad C_2 = \begin{pmatrix} 0 & 1 & 0 & 0 \\ 0 & -v_{\min} & 1 & 0 \end{pmatrix}$$

Note that in (71), $f(t)$ describes an additive fault but it can also represent a class of parametric faults. Indeed assume that parametric faults occur, this can be represented as follows

$$y(t) = \begin{pmatrix} 0 & 1 + p_1(t) & 0 & 0 \\ 0 & -v_x(t) & 1 + p_2(t) & 0 \end{pmatrix} x(t) \quad (72)$$

$$= \underbrace{\begin{pmatrix} 0 & 1 & 0 & 0 \\ 0 & v_x(t) & 1 & 0 \end{pmatrix}}_{C(v_x(t))} x(t) + \underbrace{\begin{pmatrix} p_1(t)x_2(t) \\ p_2(t)x_3(t) \end{pmatrix}}_{f(t)} \quad (73)$$

where $p_1(t)$ and $p_2(t)$ are sensor parametric faults. The longitudinal velocity is assumed to be available at real-time and fault-free. The proposed fault tolerant controller can now be implemented.

5.2. Residual generator

In order to perform fault detection and isolation, the following residual generator is constructed by solving the optimization problem given in the theorem 1

$$\begin{cases} \dot{\hat{x}}(t) = \sum_{i=1}^2 \mu_i(v_x(t)) (A_i x(t) + B_{i\delta_f} \delta_f(t) + Bu(t) + L_i(y(t) - \hat{y}(t))) \\ \hat{y}(t) = C \hat{x}(t) \\ r(t) = M(y(t) - \hat{y}(t)) \end{cases} \quad (74)$$

After solving the optimization problem of the theorem 1, the gains of the residual generator are computed and the simulation results are depicted in the figure 4. In this simulation, the inputs δ_f , v_x of the residual generator are taken from real data measurements (see figure 3) and the outputs $y(t)$ are those simulated by the nonlinear system with nonlinear tire forces F_{y_f} and F_{y_r} and sideslip angles α_f and α_r . Two faults $f_1(t)$ and $f_2(t)$ are added to system outputs. From figure 4, one can see that the residual signals estimate perfectly the faults $f_1(t)$ and $f_2(t)$.

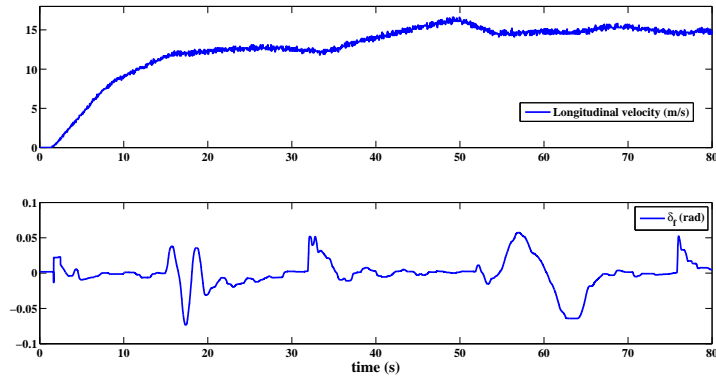

Figure 3. Real input data for the residual generator

In order to validate the residual generator with real data, the considered outputs $y(t)$ are also real obtained from adequate sensors (central unit). The faults $f_1(t)$ and $f_2(t)$ are not real but artificially included in the measurement outputs. The obtained residual signals are depicted in the figure 5.

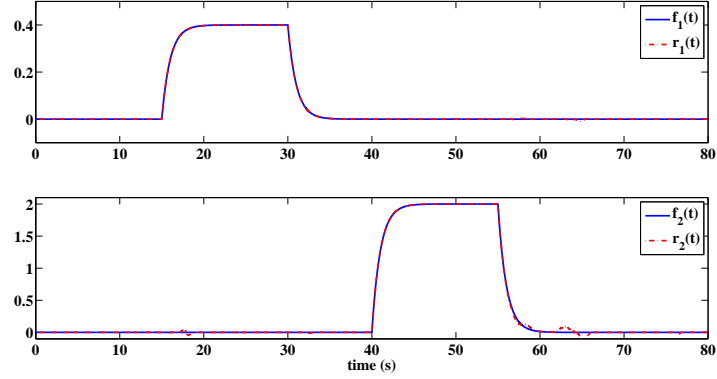

Figure 4. Residual generation: (top) fault $f_1(t)$ affecting the sensor 1 and the residual $r_1(t)$ detecting $f_1(t)$, (bottom) fault $f_1(t)$ affecting the sensor 2 and the residual $r_2(t)$ detecting $f_2(t)$

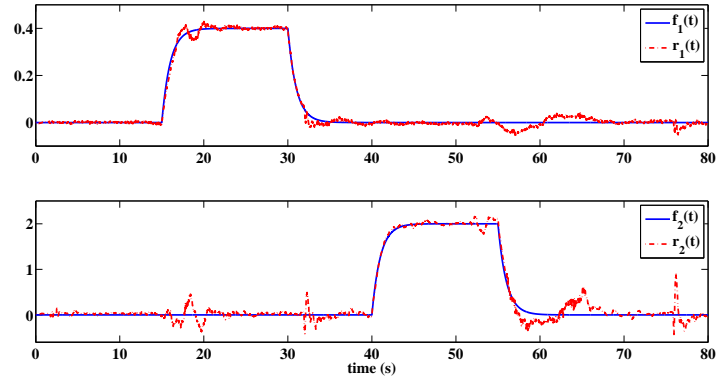

Figure 5. Residual generator validation with real measurements

5.3. Fault tolerant controller

After generating the residual signals, fault tolerant controller is designed. Firstly, the following weighting functions $h_1(r(t))$ and $h_2(r(t))$ are defined according to (12) with $\sigma_1 = \sigma_2 = 0.001$. The fault tolerant controller is designed by solving the optimization problem (24) in the theorem 2 with $\beta = 2$. A comparison between the states of the closed-loop system in both fault-free and faulty cases is illustrated in the figure 6. In this simulation, the real measurements of δ_f and v_x are used but the outputs $y(t)$ are generated by the nonlinear system explained in the previous sub-section (residual generation). One can see that the effect of the faults are completely eliminated in the state signals. The weighting functions, the faults and their estimates are depicted in the figure 7. It can be seen that when the first sensor is faulty, the weighting function $h_1(r(t))$ is close to zero and disables the faulty state obtained from the observer 1 using the first output. Similarly, when the fault $f_2(t)$ occurs in the second sensor, the state provided by the observer 2 is disabled by the weighting function $h_2(r(t))$.

In order to compare the obtained result, a classical observer-based controller is designed by using the two outputs of the system [1, 27] without taking into account the faults. In the same simulation conditions, the closed-loop system is simulated in fault-free and faulty cases as illustrated in the figure 8. One can see that, with this classical closed-loop control, the faults clearly affect the state vector. Integrating the yaw rate $\dot{\psi}(t)$ from the initial angle $\psi(0) = 0$, the vehicle trajectory from its

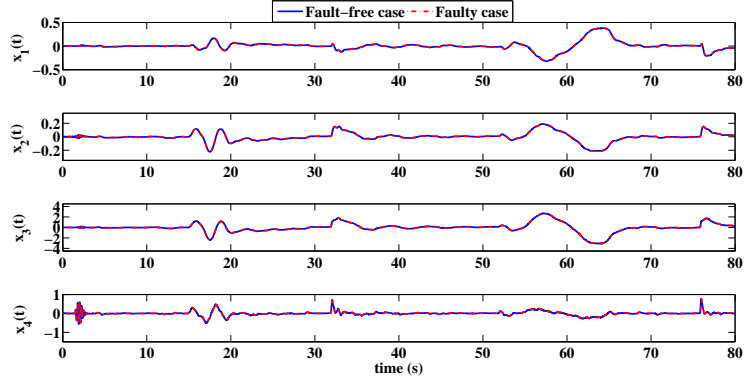

Figure 6. States of the closed-loop system in faulty and fault-free cases with the proposed FT control

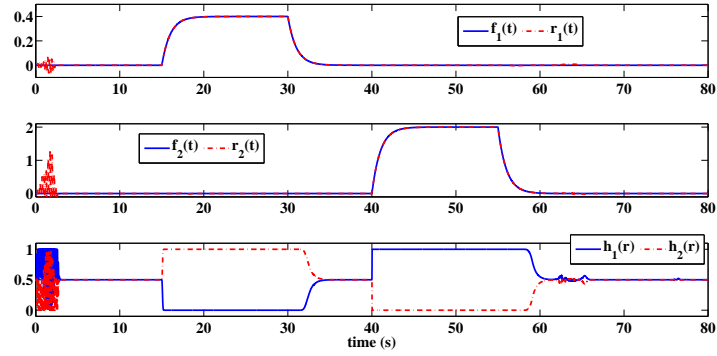

Figure 7. Faults, residual signals and weighting functions $h_i(r(t))$

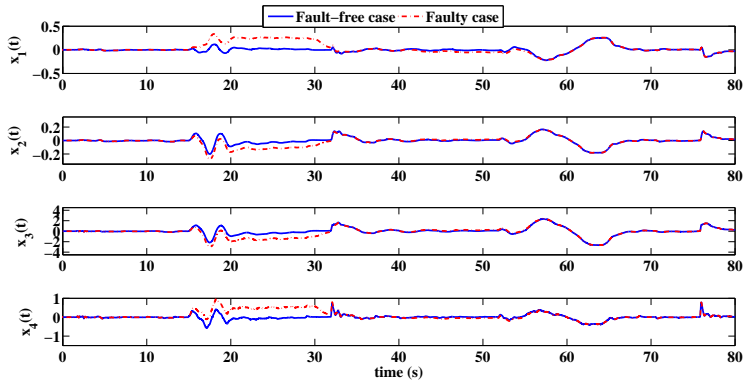

Figure 8. Classical control in both faulty and fault-free situations

initial position $x(0) = y(0) = 0$ can be computed from the following equations

$$\begin{cases} x(t) = \int_0^t (\cos(\psi(t))v_x(t) - \sin(\psi(t))v_y(t)) dt \\ y(t) = \int_0^t (\sin(\psi(t))v_x(t) + \cos(\psi(t))v_y(t)) dt \end{cases} \quad (75)$$

The trajectories of the fault-free vehicle in open-loop, the faulty sensors with FTC and the faulty sensors with classical control are illustrated in the figure 9. As an illustration of the efficiency of the proposed FT controller, in the faulty case with FTC the trajectory is close to the one in the fault free case, whereas a classical controller cannot counteract the effect of the fault on the vehicle trajectory.

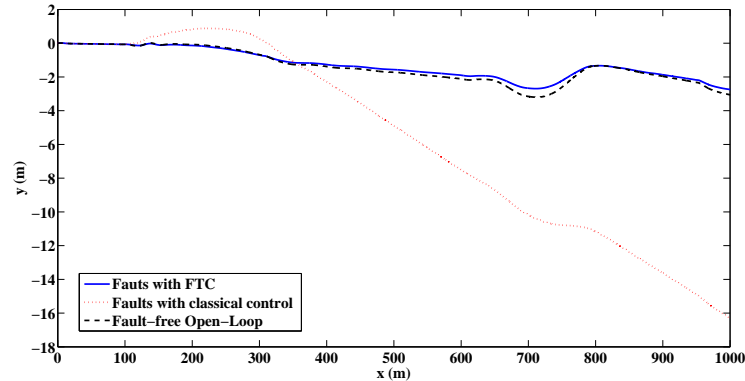

Figure 9. Vehicle trajectories

6. CONCLUSIONS

In this paper, a novel approach is proposed to design a sensor fault tolerant controller for nonlinear systems represented by a T-S model. The approach is based on a bank of observer-based controllers, a residual generator for diagnosis and a smooth selecting mechanism to choose an adequate state estimate to compensate the effects of the faults on the measurements. The stability of the whole system is studied by the Lyapunov theory and LMI constraints are provided to design the gain matrices of the different components of the proposed FTC scheme. For future works, it will be interesting to consider the case of T-S systems with unmeasurable premise variables. It is also interesting to study the choice of the functions $h_k(r(t))$. Finally, the dedicated scheme may be inapplicable in some cases since the system state needs to be reconstructed based on each output. Consequently the proposed strategy could be extended using a Generalized Observer Scheme.

REFERENCES

1. Tanaka K, Wang H. *Fuzzy Control Systems Design and Analysis: A Linear Matrix Inequality Approach*. John Wiley and Sons, 2001.
2. Murray-Smith R, Johansen T. *Multiple Model Approaches to Modelling and Control*. Taylor and Francis, London, 1997.
3. Gasso G, Mourot G, Ragot J. Environmental systems modelling and diagnosis using a multiple model approach. *5th International FLINS Conference on Computational Intelligent Systems for Applied Research*, Gent, Belgium, 2002.
4. Orjuela R, Marx B, Ragot J, Maquin D. State estimation for non-linear systems using a decoupled multiple model. *International Journal on Modelling, Identification and Control* 2008; **4**(1):59–67, doi:10.1504/IJMIC.2008.021000.
5. Chadli M, Maquin D, Ragot J. Non quadratic stability analysis of Takagi-Sugeno systems. *IEEE Conference on Decision and Control, CDC'2002*, Las Vegas, Nevada, USA, 2002, doi:10.1109/CDC.2002.1184847.
6. Guerra TM, Kruszewski A, Vermeiren L, Tirmant H. Conditions of output stabilization for nonlinear models in the Takagi-Sugeno's form. *Fuzzy Sets and Systems* 2006; **157**(9):1248–1259, doi:10.1016/j.fss.2005.12.006.
7. Kruszewski A, Wang R, Guerra T. Nonquadratic stabilization conditions for a class of uncertain nonlinear discrete time TS fuzzy models: A new approach. *IEEE Transactions on Automatic Control* Mar 2008; **53**(2):606–611, doi: 10.1109/TAC.2007.914278.
8. Johansson M. Piecewise linear control systems. PhD Thesis, Department of Automatic Control, Lund Institute of Technology, Sweden 1999.
9. Tanaka K, Hori T, Wang H. A multiple Lyapunov function approach to stabilization of fuzzy control systems. *IEEE Transactions on Fuzzy Systems* 2003; **11**(4):582–589, doi:10.1109/TFUZZ.2003.814861.

10. Tuan H, Apkarian P, Narikiyo T, Yamamoto Y. Parameterized linear matrix inequality techniques in fuzzy control system design. *IEEE Transactions on Fuzzy Systems* 2001; **9**:324–332, doi:10.1109/91.919253.
11. Sala A, Ariño C. Asymptotically necessary and sufficient conditions for stability and performance in fuzzy control: Applications of Polyá's theorem. *Fuzzy Sets and Systems* 2007; **158**(24):2671–2686, doi:10.1016/j.fss.2007.06.016.
12. Bergsten P, Palm R, Driankov D. Observers for Takagi-Sugeno fuzzy systems. *IEEE Transactions on Systems, Man, and Cybernetics - Part B: Cybernetics* 2002; **32**(1):114–121, doi:10.1109/3477.979966.
13. Akhenak A, Chadli M, Ragot J, Maquin D. Fault detection and isolation using sliding mode observer for uncertain Takagi-Sugeno fuzzy model. *16th Mediterranean Conference on Control and Automation*, Ajaccio, France, 2008, doi:10.1109/MED.2008.4602239.
14. Yoneyama J. H_∞ filtering for fuzzy systems with immeasurable premise variables: an uncertain system approach. *Fuzzy Sets and Systems* 2009; **160**(12):1738–1748, doi:10.1016/j.fss.2008.09.012.
15. Ichalal D, Marx B, Ragot J, Maquin D. An approach for the state estimation of Takagi-Sugeno models and application to sensor fault diagnosis. *48th IEEE Conference on Decision and Control, CDC'09*, Shanghai, P.R. China, 2009, doi:10.1109/CDC.2009.5400028.
16. Chen W, Saif M. Design of a TS based fuzzy nonlinear unknown input observer with fault diagnosis applications. *American Control Conference*, New York City, USA, 2007, doi:10.1109/ACC.2007.4282181.
17. Marx B, Koenig D, Ragot J. Design of observers for Takagi Sugeno descriptor systems with unknown inputs and application to fault diagnosis. *IET Control Theory and Application* 2007; **1**(5):1487–1495, doi:10.1049/iet-cta:20060412.
18. Ichalal D, Marx B, Ragot J, Maquin D. Fault tolerant control for Takagi-Sugeno systems with unmeasurable premise variables by trajectory tracking. *IEEE International workshop on Industrial Electronics, ISIE'10*, Bari, Italy, 2010, doi:10.1109/ISIE.2010.5637766.
19. Oudghiri M, Chadli M, El Hajjaji A. Robust observer-based fault tolerant control for vehicle lateral dynamics. *International Journal of Vehicle Design* 2008; **48**(3-4):173–189, doi:10.1504/IJVD.2008.022575.
20. Liberzon D, Morse A. Basic problems in stability and design of switched systems. *IEEE Control Systems Magazine* Oct 1999; **19**(5):59–70, doi:10.1109/37.793443.
21. Seron M, Zhuo X, De Doná J, Martínez J. Multisensor switching control strategy with fault tolerance guarantees. *Automatica* jan 2008; **44**(1):88–97, doi:10.1016/j.automatica.2007.05.024.
22. Nagy A, Mourot G, Marx B, Schutz G, Ragot J. Systematic multi-modeling methodology applied to an activated sludge reactor model. *Industrial & Engineering Chemistry Research* 2010; **49**(6):2790–2799, doi:10.1021/ie8017687.
23. Ichalal D, Marx B, Ragot J, Maquin D. Fault diagnosis in Takagi-Sugeno nonlinear systems. *7th IFAC Symposium on Fault Detection, Supervision and Safety of Technical Processes, SAFEPROCESS'2009*, Barcelona, Spain, 2009, doi:10.3182/20090630-4-ES-2003.00084.
24. Ichalal D, Marx B, Ragot J, Maquin D. Fault detection, isolation and estimation for takagi-sugeno nonlinear systems. *Journal of the Franklin Institute* 2013; **351**(7):3651–3676, doi:10.1016/j.jfranklin.2013.04.012.
25. Boyd S, El Ghaoui L, Feron E, Balakrishnan V. *Linear Matrix Inequalities in System and Control Theory*. SIAM, Philadelphia, 1994.
26. Pacejka H. *Tire and Vehicle Dynamics*. SAE International, 2005.
27. Tanaka K, Ikeda T, Wang H. Fuzzy regulators and fuzzy observers: Relaxed stability conditions and LMI-based designs. *IEEE Transactions on Fuzzy Systems* 1998; **6**(2):250–265, doi:10.1109/91.669023.