



HAL
open science

IMPROPER POISSON LINE PROCESS AS SIRSN IN ANY DIMENSION

Jonas Kahn

► **To cite this version:**

Jonas Kahn. IMPROPER POISSON LINE PROCESS AS SIRSN IN ANY DIMENSION. *Annals of Probability*, 2016, 44 (4), pp.2694-2725. hal-01131107v3

HAL Id: hal-01131107

<https://hal.science/hal-01131107v3>

Submitted on 29 Sep 2016

HAL is a multi-disciplinary open access archive for the deposit and dissemination of scientific research documents, whether they are published or not. The documents may come from teaching and research institutions in France or abroad, or from public or private research centers.

L'archive ouverte pluridisciplinaire **HAL**, est destinée au dépôt et à la diffusion de documents scientifiques de niveau recherche, publiés ou non, émanant des établissements d'enseignement et de recherche français ou étrangers, des laboratoires publics ou privés.

IMPROPER POISSON LINE PROCESS AS SIRSIN IN ANY DIMENSION

BY JONAS KAHN

Université de Lille 1, CNRS

Aldous has introduced a notion of scale-invariant random spatial network (SIRSIN) as a mathematical formalization of road networks. Intuitively, those are random processes that assign a route between each pair of points in Euclidean space, while being invariant under rotation, translation, and change of scale, and such that the routes are not too long and mainly lie on “main roads”.

The only known example was somewhat artificial since invariance had to be added using randomization at the end of the construction. We prove that the network of geodesics in the random metric space generated by a Poisson line process marked by speeds according to a power law is a SIRSIN, in any dimension.

Along the way, we establish bounds comparing Euclidean balls and balls for the random metric space. We also prove that in dimension more than two, the geodesics have “many directions” near each point where they are not straight.

1. Introduction. Scale-invariant random spatial networks (SIRSINs) are a class of random networks defined as a route between each pair of points, with three types of properties. First, invariance properties, second, guarantees on mean lengths of routes—in the Euclidean metric—and third guarantees on the mean length of intersection of a suitably truncated version of the network with a given compact set. It turns out that these conditions are enough to deeply constrain the network. For example, all SIRSINs have singly-infinite paths for which any subset is included in a route, but no such paths are doubly-infinite.

The only known example is the binary hierarchy model, in two dimensions. It consists of minimum-time paths on a dyadic grid where speed depends on

Received March 2015; revised April 2015.

AMS 2000 subject classifications. Primary 60D05; secondary 90B15, 51F99, 60G55.

Key words and phrases. Poisson line process, SIRSIN, scale-invariant random spatial network, stochastic geometry, spatial network, random metric space, Π -geodesic, many directions.

<p>This is an electronic reprint of the original article published by the Institute of Mathematical Statistics in <i>The Annals of Probability</i>, 2016, Vol. 44, No. 4, 2694–2725. This reprint differs from the original in pagination and typographic detail.</p>

the two-valuation. Invariance is obtained by a randomization construction. The latter feature is somewhat unsatisfying: the model itself is invariant, but realisations exhibit long-range dependence: observation of a small region gives much information on the network everywhere.

A more “natural” candidate for a SIRS_N is therefore the *Poisson line process model*. Intuitively, lines are thrown uniformly at random in \mathbb{R}^d , and marked with random speed limits. Slower lines are dense in \mathbb{R}^d . Then the route between two points is the minimum-time path made of segments of these lines. Remarkably, even in dimension $d \geq 3$, when random lines almost surely do not intersect, such paths exist. The whole construction is invariant. The aim of this paper is to show that the Poisson line process is indeed a SIRS_N for all $d \geq 2$.

Historically, Aldous (2014) introduced the notion of a SIRS_N, and proved a number of their properties, including those mentioned in the first paragraphs of this [Introduction](#). Aldous and Ganesan (2013) give a verbal description. The motivation was twofold.

First, Aldous and Kendall (2008) had proved that it was possible to build a road network connecting a prescribed set of points that both had routes almost as short as the segments between each pair of points, that is, the corresponding Euclidean geodesics, and total road length almost as short as the Steiner tree, that is, the shortest possible connecting network. However, the network was less efficient at small scales. Thanks to their invariance properties, SIRS_Ns have the same efficiency at all scales. It turns out that there is a trade-off: for a SIRS_N, there is a lower bound on the expected total length of the network, which is decreasing in the expected route length between two points.

The second motivation was to give a mathematical abstraction of road networks and maps, in particular online maps as they are used today. Namely, we may change viewpoint, zoom in or out, and the appearance changes little, as smaller roads are shown and hidden. SIRS_Ns are then defined as statistically invariant under translation, rotation and change of scale. Moreover, we are less interested in the roads than in the routes: how do we drive from A to B ? SIRS_Ns are thus defined by giving routes only, namely unique routes connecting pairs of points. It turns out that a notion of “main roads” at any scale can be built from the network of routes itself. To wit, the network of main roads at scale r would be the network of routes deprived of balls of radius r around their endpoints. It is finite in every compact. Similarly, Kalapala et al. (2006) have shown that a number of statistics of real road networks do not depend on scale.

Aldous (2014) proved that the binary hierarchy model was a SIRS_N, and suggested two other possible models for SIRS_N, one of which is the Poisson line process model. Kendall (2015) has then proved important properties of the Poisson line process with appropriate speeds: it does yield a random

metric space and this space is a geodesic space. Moreover, in dimension two, the geodesics are almost everywhere unique, the geodesics are locally of finite mean-length, and the subnetwork obtained from the routes connecting points of an independent Poisson point process has finite length in a compact set. The latter properties establish a “pre-SIRSN” result, but fall short of the full definition.

As a candidate for a SIRSN, Poisson line process model then fall in a large category: networks derived from geodesic spaces. Indeed, from any geodesic space, we may build a spatial network by associating to any two points the geodesic(s) connecting them. It is not obvious how one might determine when such a network is a SIRSN.

In Section 2, we give a precise definition of a SIRSN and of Poisson line processes. We also present other notation and definitions, and recall some known results, in particular that the Poisson line process with speed limits yields a random metric on \mathbb{R}^d . We then give a few basic properties of Π -paths, that is paths in this metric space. In Section 3, we give sharp bounds on the random diameter for this metric of a Euclidean ball, with a few generalizations. These estimates will be an important tool in several subsequent proofs. In Section 4, we prove that geodesics between a given pair of points are almost surely unique, in any dimension. Lemma 4.6 will play a central role: we introduce the notion of “many directions”, and the lemma states that geodesics have many directions at relevant points. A consequence is that any path using the same lines as a geodesic will contain these points. We will then conclude by noticing that geodesics between the same pair of points almost surely use the same lines (Lemma 4.7). In Section 5, we prove that geodesics have finite mean Euclidean length. Alternatively, we may see the result as supplying a stochastic control of the Euclidean diameter of balls for the metric generated by the Poisson line process. Section 6 contains the last and most important component of the proof that the Poisson line process generates a SIRSN. Intuitively, we establish a sharp control of the total length of the intersection of all infinitely many geodesics minus a ball around each endpoint, with a given ball. This corresponds to the fact that all these geodesics coalesce before hitting the ball and split after leaving it. Bounds are given using the pigeon-hole principle and the fact that relevant geodesics must use the few fast lines that hit the ball. Finally, Section 7 suggests a few potential directions of future inquiry.

2. Notation, definitions, basic properties. We follow Kendall’s (2015) notation whenever possible.

We write $B(x, r)$ for the ball with center x and radius r .

We first give the precise definition of a SIRSN. Suppose that Λ is an atom-free measure on a measurable space $(\mathcal{X}, \mathcal{B})$. Recall that a Poisson point process of intensity measure Λ is a random set of points such that for any

$B \in \mathcal{B}$, the number of points $N(B)$ in B is a Poisson variable with intensity $\Lambda(B)$, and the number of points $N(B_i)$ in disjoint B_i are independent. Then a SIRS is defined as follows.

DEFINITION 2.1. A SIRS is a process that associates to any two points x_1 and x_2 in \mathbb{R}^d random routes such that:

1. Between two specified points x_1 and x_2 , there is almost surely a unique route $\mathcal{R}(x_1, x_2) = \mathcal{R}(x_2, x_1)$. It is a finite-length path connecting x_1 and x_2 .

2. For a finite number of points x_1, \dots, x_k in \mathbb{R}^d , consider the subnetwork $\mathcal{N}(x_1, \dots, x_k)$ formed by the random routes connecting all x_i and x_j . Then $\mathcal{N}(x_1, \dots, x_k)$ is statistically invariant under translation, rotation and change of scale: if \mathfrak{A} is a Euclidean similarity of \mathbb{R}^d , then $\mathcal{N}(\mathfrak{A}(x_1), \dots, \mathfrak{A}(x_k))$ has the same distribution as $\mathfrak{A}\mathcal{N}(x_1, \dots, x_k)$.

3. Let D_1 be the length of a route between two points at unit distance. Then $\mathbb{E}[D_1] < \infty$.

4. Let $\{\Xi_n, n \in \mathbb{N}^*\}$ be a collection of Poisson processes on \mathbb{R}^d with intensity n times Lebesgue, all independent from the SIRS. Suppose they are coupled so that $\Xi_n \subset \Xi_{n+1}$. Write $\Xi = \bigcup_{n \in \mathbb{N}^*} \Xi_n$. Then the *intensity* (mean length per unit area) $p(1)$ of the following long-distance network is finite:

$$\bigcup_{x_1, x_2 \in \Xi} (\mathcal{R}(x_1, x_2)) \setminus (B(x_1, 1) \cup B(x_2, 1)).$$

Note that Kendall (2015) uses more conditions in his definition, but the missing properties are implied by property 4. They were useful to define weaker variants of a SIRS.

The use of Poisson processes in property 4 makes it look slightly complex, but this is a technical shortcut: it allows us to study the network through only countably many routes. Morally, we would like property 4 to hold true if the long-distance network was defined as the union of all routes between all pairs of points of \mathbb{R}^d , minus the balls around the endpoints. But there would be uncountably many routes, and it would be harder to work with.

We now turn to the definition of the improper Poisson line process. We first need a measure on lines. More details on this kind of process may be found in the book by Stoyan, Kendall and Mecke (1996).

Let \mathcal{L}^d be the space of all lines of \mathbb{R}^d . A line is “un-sensed”, that is, it is seen as a subset of \mathbb{R}^d , without a preferred direction. For K , a compact of \mathbb{R}^d , the *hitting set* of K is the set of lines that intersect K , denoted as

$$[K] = \{l \in \mathcal{L}^d : l \text{ hits } K\}.$$

We also denote by m_d the Hausdorff measure of dimension d . With this notation, we have the following.

DEFINITION 2.2. The *invariant line measure* $\mu_d(l)$ is the unique measure on the space of lines of \mathbb{R}^d that is invariant under Euclidean isometries, and normalized by the following requirement: for a compact set K in \mathbb{R}^d of nonempty interior, the μ_d -measure of the hitting set of K is half the Hausdorff $(d-1)$ -dimensional measure of the boundary of K :

$$\mu_d([K]) = \frac{1}{2}m_{d-1}(\partial K).$$

The reason for the normalizing constant $\frac{1}{2}$ is to ensure that the measure of the hitting set of a flat hypersurface A is its hyperarea $m_{d-1}(A)$.

We will often need the hitting set of a ball, so write ω_{d-1} for the hyperarea of the unit sphere \mathbb{S}^{d-1} . Thus $\mu_d([B(x, r)]) = \frac{\omega_{d-1}}{2}r^{d-1}$.

Consider the following parameterization of a line l : it is given by a direction and a localization. The direction is an element of the projective space $P\mathbb{R}^{d-1}$. It then defines a hyperplane normal to this direction, through a special point—the origin—of \mathbb{R}^d . The localization is a point on this hyperplane. The line l is then the line through this point normal to this hyperplane.

Hence, writing $\mathcal{H} = \mathbb{R}^{d-1}$ for an hyperplane of \mathbb{R}^d , we may parameterize the set of lines by $P\mathbb{R}^{d-1} \otimes \mathcal{H}$. Notice that if we want to keep track of the topology of the set of lines, the product should be twisted, but we only need measure-theoretical properties, so we stick to the simpler direct product.

Recall that the projective space $P\mathbb{R}^{d-1}$ may be seen as the sphere \mathbb{S}^{d-1} with opposite—antipodal—points identified. The projective space then inherits the natural metric on the sphere, namely the distance between two pairs of antipodal points is the angle between the pair of segments joining them, in radians. Up to a null-measure set, the projective space may be more simply viewed as a hemisphere.

With this parameterization, and writing \mathbb{B}^d for the unit ball in \mathbb{R}^d , we may write μ_d as a product measure on $P\mathbb{R}^{d-1} \otimes \mathcal{H}$:

$$\mu_d = \frac{1}{m_{d-1}(\mathbb{B}^{d-1})}m_{d-1} \otimes m_{d-1}.$$

To make a clearer reference to it, we write $\mu_{d-1}^{(o)} = 2m_{d-1}/m_{d-1}(\mathbb{S}^{d-1})$ for the probability measure on $P\mathbb{R}^{d-1}$. For a set of lines \mathcal{L} , we write $\mu_{d-1}^{(o)}(\mathcal{L})$ for the measure of the set of directions of lines in \mathcal{L} that go through the origin. In particular, for A a subset of \mathbb{R}^d and x a point of \mathbb{R}^d , the value $\mu_{d-1}^{(o)}([A-x])$ will be the proportion of directions that appear in the set of directions of lines through A and x . We call it the *solid angle* of A from x . Notice that it is not quite the usual definition since pairs of antipodal points contribute only once, and since we have normalized to a probability measure. This is because we are concerned with orientations of undirected lines, rather than angles of directed lines.

A special case we shall need is the measure of a cone, that is, all the lines with angle less than θ_0 from a given line through the origin. This measure is proportional to the area on the hemisphere hit by the lines, hence proportional to $\int_0^{\theta_0} \sin^{d-2} \theta \cos \theta d\theta = \sin^{d-1}(\theta_0)/(d-1)$. The integral up to $\theta_0 = \pi/2$ has value 1, so that

$$(1) \quad \mu_{d-1}^{(o)}(\text{cone of aperture } \theta_0) = \sin^{d-1}(\theta_0).$$

The uniform Poisson line process is the image of the Poisson point process on \mathcal{L}^d with intensity measure μ_d .

We define our improper Poisson line process by adding a mark on each line, a speed limit. Namely, the improper Poisson line process is the image of a Poisson point process on $P\mathbb{R}^{d-1} \otimes \mathcal{H} \otimes \mathbb{R}_*^+$ with intensity measure $\mu_{d,\gamma}$, given by the density

$$d\mu_{d,\gamma}(l, v) = d\mu_d(l)(\gamma - 1)v^{-\gamma} dv$$

for $\gamma > d$. Kendall (2015) does define this process for all $\gamma > 1$, but the relevant case for SIRSs is that of $\gamma > d$.

In words, we have more and more slower lines, following a power law. Since $\int v^{-\gamma} dv$ diverges at zero, the lines are dense in \mathbb{R}^d . However, lines faster than any given speed are not dense. In particular, the number of lines faster than v_0 hitting a convex set K is a Poisson variable with parameter

$$\begin{aligned} \mu_{d,\gamma}(\{(l, v) : l \in [K] \text{ and } v \geq v_0\}) &= \mu_d([K]) \int_{v_0}^{\infty} (\gamma - 1)v^{-\gamma} dv \\ &= \frac{1}{2} m_{d-1}(\partial K) v_0^{-(\gamma-1)}. \end{aligned}$$

We call $\Pi = \Pi(d, \gamma)$ the corresponding random process of marked lines (l, v) . Since the dimension d and parameter γ will always be clear from context, we drop them in the notation. Notice that the total number of lines is almost surely countable. If $(l, v) \in \Pi$, we say that the speed of line l is v and denote it $v(l)$.

For a subset \mathcal{L} of lines, we write $\Pi_{\mathcal{L}}$ for the restriction of Π to these lines, that is, $\Pi_{\mathcal{L}} = \{(l, v) : l \in \mathcal{L}\}$. In particular, the line process restricted to lines hitting A but not B is $\Pi_{[A] \setminus [B]}$.

We denote \mathcal{S} the *silhouette* of Π , that is the random set in \mathbb{R}^d made of all the lines of Π , that is $\mathcal{S} = \{x \in \mathbb{R}^d : \exists (l, v) \in \Pi : x \in l\}$. We also write \mathcal{S}_{v_0} for the random closed set in \mathbb{R}^d made of all the lines (l, v) in Π such that $v \geq v_0$.

We may then define Π -paths.

DEFINITION 2.3. A finite-time Π -path is a locally Lipschitz path in \mathbb{R}^d respecting the speed limits imposed by Π . More precisely, it is a continuous

\mathbb{R}^d -valued function

$$\xi : [0, T] \rightarrow \mathbb{R}^d,$$

with T finite, such that for almost all $t \in [0, T]$, either:

- the speed is zero: $\xi'(t) = 0$;
- or the path follows a line in Π : there is a $v \geq |\xi'(t)|$ such that $(\xi(t) + \xi'(t)\mathbb{R}, v) \in \Pi$.

We call $T = T(\xi)$ the *time length* of the path ξ , or just its *time* for short.

An infinite-time Π -path ξ is the same, with $T(\xi) = \infty$, except that its domain is $[0, \infty)$.

A Π -path is a finite or infinite-time Π -path.

In an abuse of notation, we write $\xi \in \Pi$.

Notice that the image of a Π -path is not necessarily contained in the silhouette \mathcal{S} . It only needs to have speed zero outside \mathcal{S} . The remark is especially relevant in dimension at least three, where the lines never cross. However, since the lines are dense in \mathbb{R}^d , it turns out that there are paths joining any pair of points, without any segment in $\mathbb{R}^d \setminus \mathcal{S}$. We give a clearer intuition of their tree-like structure in the proof of Theorem 3.1 and Figure 1.

We write $\Pi^{ab} = \{\xi \in \Pi : \xi(0) = a \text{ and } \xi(T(\xi)) = b\}$ for any two points a and b .

The following theorem is a union of results from Kendall's (2015) paper.

THEOREM 2.4. *Almost surely, all finite-time Π -paths have finite Euclidean length.*

Almost surely, there are finite-time Π -paths between each pair of points of \mathbb{R}^d . Moreover, for any two points a and b , the infimum T_{ab} of time lengths $T(\xi)$ of Π -paths $\xi \in \Pi^{ab}$ is attained.

Hence, \mathbb{R}^d with the metric $d(a, b) = T_{ab}$ is a random metric geodesic space.

We call this metric *time length* or Π -*length*. Time diameters and similar notions are defined in the same way.

We denote by \mathcal{N} the random network made by all the geodesics connecting all pairs of points in \mathbb{R}^d . Our aim is to show that \mathcal{N} is a SIRSN.

It is often possible to define similar metrics on other sets Γ of marked lines, though they might not be geodesic. We then speak of Γ -length. The typical case is when we restrict Π to a subset of lines \mathcal{L} , yielding $\Gamma = \Pi_{\mathcal{L}}$ and $\Pi_{\mathcal{L}}$ -length.

We now introduce some notation and remarks to make easier manipulating paths and geodesics:

- If $\xi \in \Pi^{ab}$, we often write ξ_{ab} instead.

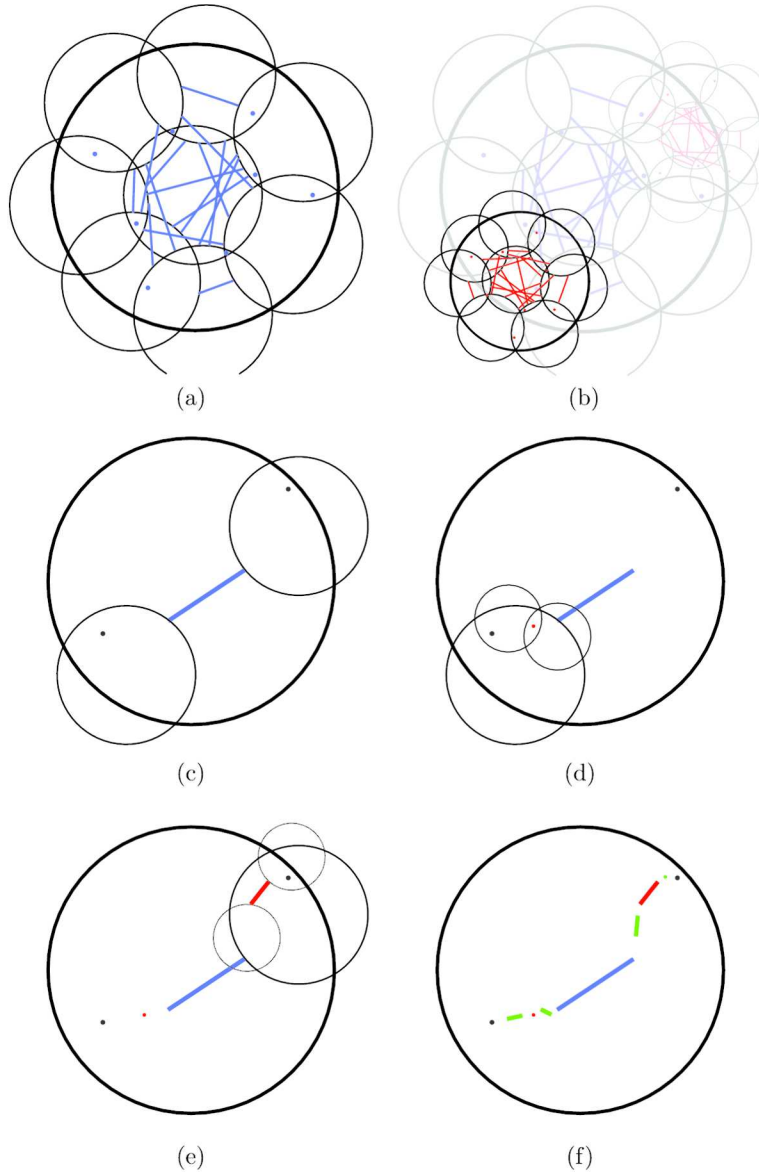

FIG. 1. We cover each ball B_i with a r_1 -net, and connect each pair of balls of the net with a segment, be it a point (a). We then do the same at each scale, for r_{n+1} -nets of the balls of the r_n -nets (b). Each point belongs to a ball of the r_1 -net, so we build a path between two points starting from the segment connecting their balls (c). We then (d) and (e) connect the points to the segment endpoints with the segment connecting their balls in their respective r_2 -nets. At stage n , the path (f) is made of 2^n segments at each scale n .

- Concatenation of Π -paths is denoted $\xi_{ac} = \xi_{ab}\xi_{bc}$, that is, $\xi_{ac}(t) = \xi_{ab}(t)$ if $t < T(\xi_{ab})$, and $\xi_{ac}(t) = \xi_{bc}(t - T(\xi_{ab}))$ if $t \geq T(\xi_{ab})$.
- We use the letter g for geodesics, and usually g_{ab} for a geodesic from a to b . We say that g_{ab} is unique if there is a unique geodesic from a to b .
- In an abuse of notation, we identify a Π -path ξ with its image in \mathbb{R}^d whenever it is clear. Hence, we may write $x \in \xi$ if there is a time t such that $\xi(t) = x$. Similarly, if g_{ab} is unique and $c, d \in g_{ab}$, we say that g_{cd} is included in g_{ab} .
- If g_{ab} is unique and $c \in g_{ab}$, then $g_{ab} = g_{ac}g_{cb}$.
- $T(g_{ab}) = T_{ab}$.
- For a line $l \in \Pi$ and a Π -path $\xi : [0, T] \rightarrow \mathbb{R}^d$, we define the *intersection length* of ξ and l as $L_\xi(l) \hat{=} m_1(l \cap \xi([0, T]))$.
- If the intersection length of ξ and l is not zero, we say that l is in the *support* of ξ , or that it is supporting ξ . We write $l \sqsubset \xi$. Moreover, we denote the support of ξ by $\mathcal{L}_\xi \hat{=} \{l \in \Pi : L_\xi(l) > 0\}$.
- We define the *intersection time* of l and ξ as $T_\xi(l) \hat{=} m_1([0, T] \cap \xi^{-1}(l))$.
- In particular, almost surely, for all geodesics g , we have the following equality and decompositions:

$$(2) \quad \begin{aligned} L_g(l) &= v(l)T_g(l) && \text{for all } l \in \Pi, \\ T(g) &= \sum_{l \in \mathcal{L}_g} T_g(l) \\ &= \sum_{l \in \mathcal{L}_g} v(l)L_g(l). \end{aligned}$$

- If the support of ξ is included in \mathcal{L} , that is $\mathcal{L}_\xi \subset \mathcal{L}$, we say that ξ is $\Pi_{\mathcal{L}}$ -path. We abuse notation by writing $\xi \in \Pi_{\mathcal{L}}$.
- Similarly, we write $\xi \in \Pi_{\mathcal{L}}^{ab}$ if $\xi \in \Pi_{\mathcal{L}}$ and $\xi \in \Pi^{ab}$.

Finally, a few more generic notation. We call *internal ε -net* of a subset A of \mathbb{R}^d any maximal subset x_1, \dots, x_k of A such that $|x_i - x_j| \geq \varepsilon$ for all $i \neq j$. For a set $A \subset \mathbb{R}^d$, we write A^r for its r -widening, that is the Minkowski sum $A^r = A \oplus B(0, r)$. We denote the maximal speed of a set of lines \mathcal{L} by $v_{\max}(\mathcal{L})$. That is, $v_{\max}(\mathcal{L}) = \sup_{l \in \mathcal{L}} v(l)$. Notice that if those lines all hit a compact set K , this supremum is a maximum. We abuse notation by writing $v_{\max}(A) = v_{\max}([A])$ for $A \in \mathbb{R}^d$. We use C, c, c_1, \dots, c_i for any positive constant.

3. Π -diameters of sets. We start with giving a more quantitative version of Theorem 3.6 in Kendall's (2015) article. Namely, we show that in a given precompact set A , any two points can be joined in finite time, and that the largest time between two such points—the Π -diameter of A —is not too big with high probability: this random variable has more than an exponential

moment. We include a generalization that we will need later on, by allowing the possibility of ignoring lines hitting forbidden areas F .

THEOREM 3.1. *Recall that $d \geq 2$ and $\gamma > d$. Let $\alpha_{\min} = 2^{(\gamma-1)/(\gamma-d)}$. Let $\Omega < \Omega_{\max} = (4\alpha_{\min})^{1-d}$ and define $\alpha_{\max} = \Omega^{-1/(d-1)}/4$. Choose α such that $\alpha_{\min} < \alpha < \alpha_{\max}$, and note in particular that $\alpha > 1$.*

Let A and F be two subsets of \mathbb{R}^d , such that, for some $r > 0$:

- *A is connected.*
- *From any $x \in A^{r/(\alpha-1)}$, the solid angle $\mu_{d-1}^{(o)}([F-x])$ of F is less than Ω .*
- *A may be covered by \mathring{N} balls B_i of radius r .*

Then there is a T_1 depending only on α , Ω , γ and d such that, for any $\varepsilon_{\max} = 1/(2\mathring{N}(2\alpha+1)^d) > \varepsilon > 0$, with probability $1 - \varepsilon/\varepsilon_{\max}$, the diameter of A on $\Pi_{[A^{r/(\alpha-1)}] \setminus [F]}$ satisfies the bound

$$(3) \quad \begin{aligned} T_{A,F} &\hat{=} \sup_{x,y \in A} \inf_{\xi \in \Pi_{[A^{r/(\alpha-1)}] \setminus [F]}^{xy}} T(\xi) \\ &\leq T_{r,\mathring{N}} \left(\ln \frac{1}{\varepsilon} \right)^{1/(\gamma-1)} \quad \text{with} \\ T_{r,\mathring{N}} &= \mathring{N} T_1 r^{(\gamma-d)/(\gamma-1)}. \end{aligned}$$

In particular, this maximal time has all exponential moments, and more: for any $\delta < T_{r,\mathring{N}}^{-1/(\gamma-1)}$, we have

$$(4) \quad \mathbb{E}[\exp(\delta T_{A,F}^{\gamma-1})] < \infty.$$

The proof is a slight variation on that of Theorem 3.6 in [Kendall's \(2015\)](#) article.

PROOF OF THEOREM 3.1. Since A is connected and covered by \mathring{N} open balls B_i of radius r , we may build a path between any two points of A by concatenating at most \mathring{N} paths between two points of A belonging to the same ball B_i of the cover.

We now recursively build a path between each pair of points x_0 and y_0 of B_i , in a binary tree-like fashion. First, we specify

$$r_n = r\alpha^{-n}.$$

We will choose corresponding speed limits v_n later. Given such v_n :

- We call A_0 the set of balls $\{B_i\}_{1 \leq i \leq \mathring{N}}$.

- To any ball $B^{(n)} \in A_n$, we associate an internal r_{n+1} -net of that ball. It may be viewed as a collection of balls $B^{(n+1)}$ of radius r_{n+1} . We then define A_{n+1} as the set of all these balls $B^{(n+1)}$ for all $B^{(n)}$ together.
- We have thus built nested internal r_n -nets.
- For any two balls $B_i^{(n+1)}$ and $B_j^{(n+1)}$ belonging to the internal r_{n+1} -net of the same ball $B^{(n)}$ in A_n , we find a line of speed at least v_n that hits both $B_i^{(n+1)}$ and $B_j^{(n+1)}$, but not F . We will have to prove this is possible with high enough probability.
- For x_n and y_n , both belonging to $B^{(n)} \in A_n$, we may then find two points x_{n+1} and y_{n+1} such that: x_n and x_{n+1} (resp., y_n and y_{n+1}) belong to the same ball $B_i^{(n+1)} \in A_n$ (resp., $B_j^{(n+1)}$), and x_{n+1} and y_{n+1} both belong to the same line of speed at least v_n .
- We may then build a path between x_n and y_n as a concatenation of three paths: $\xi_{x_n y_n} = \xi_{x_n x_{n+1}} \xi_{x_{n+1} y_{n+1}} \xi_{y_{n+1} y_n}$. The middle one is a segment. The other two are paths between points of the same ball in A_{n+1} .

As illustrated in Figure 1, we thus obtain a path between x_0 and y_0 that is made of exactly 2^n segments for each n , each at speed at least v_n between two balls of the same internal r_{n+1} -net of a ball of radius r_n . Moreover, since the points x_0 and y_0 are in A , all of the segments are between points of the Minkowski sum $A \bigoplus_{n=1}^{\infty} B(0, r_n) = A^{r/(\alpha-1)}$.

This construction has built a path for each pair of points x_0 and y_0 in B_i . Since segments between balls of the same internal r_{n+1} -net of a ball of radius r_n are at most $(2r_n + 2r_{n+1})$ long, and are at speed at least v_n , the $\Pi_{[A^{r/(\alpha-1)}] \setminus [F]}$ -diameter $T_{A,F}$ of A is bounded from above by

$$(5) \quad T_{A,F} \leq \overset{\circ}{N} \sum_{n=1}^{\infty} 2^n \frac{2r_n + 2r_{n+1}}{v_n},$$

on the event that this construction is possible.

Now to control the probability of this event, we need:

- a bound on the number of pairs of balls in the same r_n -net;
- a bound on the probability that the fastest line hitting two such balls but not F is slower than v_n .

We obtain the first bound by using the formula $r_n = \alpha^{-1} r_{n-1}$. Indeed, each r_n -net of a r_{n-1} -ball is then the same as a α^{-1} -net of a radius 1 ball. Since the balls $B(s_i, 1/(2\alpha))$ centered on the points of such a α^{-1} -net are disjoint, and all included in a ball of radius $1 + 1/(2\alpha)$, a volume argument shows that there at most $(2\alpha + 1)^d$ balls in each r_n -net. So that there are at most $\overset{\circ}{N}(2\alpha + 1)^{dn}$ balls in A_n , and at most $\overset{\circ}{N}(2\alpha + 1)^{d(n+1)}$ pairs of balls in the same r_n -net.

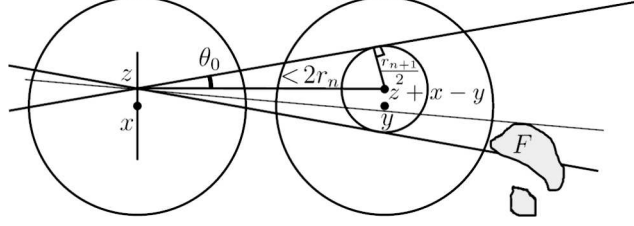

FIG. 2. Lines that hit both balls $B(x, r_{n+1})$ and $B(y, r_{n+1})$ but not F (not necessarily connected) contain lines through $z \in D(x, r_{n+1}/2)$ and $B(z + x - y, r_{n+1}/2)$. These are included in the cone of angle θ_0 through z .

We now consider these lines that hit both of two r_{n+1} -balls $B(x, r_{n+1})$ and $B(y, r_{n+1})$ in an internal r_{n+1} -net of a r_n -ball, but that do not hit F . We have seen that they were in $[A^{r/(\alpha-1)}]$. We may then use the hypothesis of the theorem on the solid angle of F .

We want a bound on

$$\mu_d([B(x, r_{n+1})] \cap [B(y, r_{n+1})] \cap [F]^c).$$

Now, as illustrated in Figure 2, let $D(x, r_{n+1}/2)$ be the hyperdisk centered on x with radius $r_{n+1}/2$ and included in the hyperplane perpendicular to the vector $x - y$. It is included in $B(x, r_{n+1})$. Moreover, for any $z \in D(x, r_{n+1}/2)$, the ball $B(z + y - x, r_{n+1}/2)$ is included in $B(y, r_{n+1})$.

Now we may write

$$\begin{aligned} & \mu_d([B(x, r_{n+1})] \cap [B(y, r_{n+1})] \cap [F]^c) \\ & \geq m_{d-1}(D(x, r_{n+1}/2)) \\ & \quad \times \inf_{z \in D(x, r_{n+1}/2)} \mu_{d-1}^{(o)}([B(y - x, r_{n+1}/2)] \cap [F - z]^c) \\ & \geq m_{d-1}(D(x, r_{n+1}/2)) \times (\mu_{d-1}^{(o)}([B(y - x, r_{n+1}/2)]) - \Omega). \end{aligned}$$

Now, $y - x \leq 2r_n = 2\alpha r_{n+1}$. So that the lines in $[B(y - x, r_{n+1}/2)]$ are in a cone of angle θ_0 such that $\sin(\theta_0) \leq (4\alpha)^{-1}$. So that by formula (1):

$$(6) \quad \mu_{d-1}^{(o)}([B(y - x, r_{n+1}/2)]) \leq (4\alpha)^{1-d}.$$

Since $\alpha < \alpha_{\max}$, we have $(4\alpha)^{1-d} - \Omega > 0$.

Moreover, with ν_{d-1} the $(d-1)$ -volume of a unit $(d-1)$ -ball, we have

$$m_{d-1}(D(x, r_{n+1}/2)) = \nu_{d-1} \left(\frac{r_{n+1}}{2} \right)^{d-1},$$

$$\begin{aligned} \mu_d([B(x, r_{n+1})] \cap [B(y, r_{n+1})] \cap [F]^c) & \leq \nu_{d-1} ((4\alpha)^{1-d} - \Omega) \left(\frac{r_{n+1}}{2} \right)^{d-1} \\ & \doteq c_{\alpha, \Omega} r_{n+1}^{d-1}, \end{aligned}$$

using the notation $c_{\alpha,\Omega}$ to summarize and emphasize that this bound depends on α and Ω , but not on n , r , or any other feature of A and F .

We thus get

$$\mathbb{P}[v_{\max}([B(x, r_{n+1})] \cap [B(y, r_{n+1})] \cap [F]^c) \leq v_n] \leq \exp\left(-c_{\alpha,\Omega} \frac{r_{n+1}^{d-1}}{v_n^{\gamma-1}}\right).$$

Multiplying by the number of relevant pairs of ball, we then obtain that the construction is possible except on an event of probability at most

$$(7) \quad \sum_{n=0}^{\infty} \mathring{N} (2\alpha + 1)^{d(n+1)} \exp\left(-c_{\alpha,\Omega} \frac{r_{n+1}^{d-1}}{v_n^{\gamma-1}}\right).$$

Taking

$$v_n = \frac{r_{n+1}^{(d-1)/(\gamma-1)}}{((n+1)c_{\alpha,\Omega} \ln(1/\varepsilon))^{1/(\gamma-1)}}$$

and replacing in bound (7), we see that this becomes less than

$$\sum_{n=0}^{\infty} \mathring{N} (2\alpha + 1)^{d(n+1)} \varepsilon^{n+1} \leq \frac{\varepsilon}{\varepsilon_{\max}},$$

for $\varepsilon < 1/(2\mathring{N}(2\alpha + 1)^{d(n+1)}) = \varepsilon_{\max}$, so that ε_{\max} does not depend on A or F except through α and \mathring{N} .

Replacing v_n and r_n with their value in the bound (5), we get

$$\begin{aligned} T_{A,F} &\leq \mathring{N} \sum_{n=1}^{\infty} 2^{n+1} (1 + \alpha) \frac{r_{n+1}}{v_n} \\ &= \mathring{N} \left((1 + \alpha) c_{\alpha,\Omega}^{1/(\gamma-1)} \sum_{n=2}^{\infty} (2\alpha^{-(\gamma-d)/(\gamma-1)})^n n^{1/(\gamma-1)} \right) \\ &\quad \times r^{(\gamma-d)/(\gamma-1)} \left(\ln\left(\frac{1}{\varepsilon}\right) \right)^{1/(\gamma-1)}, \end{aligned}$$

where the first parentheses correspond to T_1 and T_1 is finite since $\alpha > \alpha_{\min}$. We have thus proved formula (3) of the theorem.

The moment (4) is simple integration:

$$\begin{aligned} \mathbb{E}[\exp(\delta T_{A,F}^{\gamma-1})] &\leq C + \frac{1}{\varepsilon_{\max}} \int_0^{\varepsilon_{\max}} \exp\left(\delta \left(T_{r,\mathring{N}} \left(\ln \frac{1}{\varepsilon}\right)^{1/(\gamma-1)}\right)^{\gamma-1}\right) d\varepsilon \\ &\leq C + \frac{1}{\varepsilon_{\max}} \int_0^{\varepsilon_{\max}} \frac{1}{\varepsilon} \exp(-\delta T_{r,\mathring{N}}^{1/(\gamma-1)}) d\varepsilon \\ &< \infty. \end{aligned}$$

Here, we use $\delta < T_{r, \overset{\circ}{N}}^{-1/(\gamma-1)}$ and C corresponds to the integral between ε_{\max} and 1, bounded by the value of $T_{A,F}$ for $\varepsilon = \varepsilon_{\max}$. \square

REMARK 3.1. If no lines are forbidden, that is if $F = \emptyset$, then α can be taken as big as we wish, so that the lines used all hit as small a widening of A as we want.

We may slightly generalize the theorem: instead of using a forbidden area F , we could use different conditions for which lines to accept. The important property is that we must have enough relevant lines hitting pairs of balls in a r_{n+1} -net.

There are a few optimisations that could be used to gain slightly in the constants. For example, we have written the proof with one subnet inside each ball. If we had used a single r_n -net of a correctly widened A , we would have only about $\overset{\circ}{N}2^d \alpha^{d(n+1)}$ pairs of ball, allowing a bigger ε_{\max} . The result stays essentially the same, however, as proven by the following proposition.

PROPOSITION 3.2. *For any two points x and y , their Π -distance T_{xy} does not have a moment with higher exponent on the time T_{xy} than in formula (4). That is, for any $\delta > 0$, for any $\eta > \gamma - 1$, we have*

$$\mathbb{E}[\exp(\delta T_{xy}^\eta)] = \infty.$$

PROOF. Say that $|x - y| = r$. A path from x to y has to go from x to the border of $B(x, r)$. Hence, it must use lines hitting $B(x, r)$ for a length at least r . So that T_{xy} is controlled by the fastest line hitting $B(x, r)$. Now,

$$\mathbb{P}[v_{\max}(B(x, r)) \leq v_\varepsilon] = \exp(-c(r)v_\varepsilon^{1-\gamma}) = \varepsilon$$

with

$$v_\varepsilon = \left(\frac{1}{c(r)} \ln \frac{1}{\varepsilon} \right)^{1/(1-\gamma)},$$

where $c(r)$ depends only on r .

So that on an event of probability at least ε , we have the bound $T_{xy} \geq r/v_\varepsilon = c_2(r)(\ln(1/\varepsilon))^{1/(\gamma-1)}$. Hence, for some positive constant c_3 depending on δ , η and r :

$$\begin{aligned} \mathbb{E}[\exp(\delta T_{xy}^\eta)] &\geq \int_0^1 \exp\left(-c_3 \left(\ln \frac{1}{\varepsilon}\right)^{\eta/(\gamma-1)}\right) d\varepsilon \\ &= \infty, \end{aligned}$$

since $\eta/(\gamma - 1) > 1$. \square

4. Almost sure uniqueness of Π -geodesics. In this section, we prove that the network \mathcal{N} satisfies the property 1 of a SIRSN, that is that between two specified points x and y in \mathbb{R}^d , there is almost surely only a unique route. Since routes are the Π -geodesics, this is equivalent to almost sure uniqueness of the geodesic g_{xy} .

The case in dimension 2 has already been established in Kendall's (2015) paper. The following proof, on the other hand works in all dimensions more than 2, as stated in Theorem 4.8. Note that it does not work in dimension 2.

The strategy is the following:

- We introduce a concept of *many directions*, with the following property. If a Π -path has many directions near a point x , any finite Π -path supported by the same lines contains x .
- We show that almost surely all geodesics have many directions near all the ends of their component segments, except for the two extremal points. This is the step where $d \geq 3$ is needed.
- We show that for specified x and y in \mathbb{R}^d , almost surely all geodesics from x to y are supported exactly on the same lines.
- So that almost surely all such geodesics contain the same segment ends, and this will prove they are the same.

The author thinks the proof is very technical for something that looks clear enough, but could not find an easier way. Maybe the need to work with tree-like paths in dimension at least three is the reason why there is no obvious argument. Hopefully, the concept of many directions can be useful elsewhere.

We first state two technical lemmas we need for the proofs in Section 4.1. We introduce the notion of “many directions” and give some cases where paths have many directions in Section 4.2, culminating in Lemma 4.6. We prove that geodesics must use the same lines in Section 4.3, and end the proof of uniqueness in Section 4.4.

4.1. Technical lemmas. The first lemma yields a control on the proportion of balls in a nested set that are hit by lines faster than a threshold appropriately scaling with their size.

LEMMA 4.1. *Let $d \geq 2$. Let $\alpha > 1$ be a scale factor. We write $p = \alpha^{1-d} < 1$. Let $B_i = B(x_i, r_i)$ for $1 \leq i \leq n$ be a set of nested balls with $r_i = r_0/\alpha^i$ for some r_0 . For some v_0 , define*

$$\begin{aligned} v_i &= v_0 p^{i/(\gamma-1)}, \\ \mathcal{V}_0 &= \{(l, v) \in \Pi : v \geq v_0\}, \\ \mathcal{V}_i &= \{(l, v) \in \Pi : v_{i-1} \geq v \geq v_i\}. \end{aligned}$$

Define now H_i as the number of balls B_{i+k} smaller than B_i that are hit by lines faster than v_i , and I_n as the number of balls B_i that are hit by lines faster than v_{i-1} , that is,

$$H_i = \#\{k > 0 : \mathcal{V}_i \cap [B_{i+k}] \neq \emptyset\},$$

$$I_n = \#\{i \leq n : \exists k > 0 : [B_i] \cap \mathcal{V}_{i-k} \neq \emptyset\} \leq \sum_{i=0}^{n-1} H_i.$$

Then $\lambda \hat{=} \mathbb{E}[\#\{\mathcal{V}_i \cap [B_i]\}] = (1-p)\omega_{d-1}r_0^{d-1}/(2v_0^{\gamma-1})$ independently of $i \geq 1$. Then, for any $\delta > 0$:

$$(8) \quad \mathbb{P}[I_n > \delta n] \leq \left((1 + \lambda\delta) \left(\frac{1 + \delta}{\delta} \right)^\delta p^\delta \right)^n.$$

Precise but more cumbersome bounds are given in equations (11) and (12).

PROOF. We have

$$\begin{aligned} \mathbb{E}[\#\{\mathcal{V}_i \cap [B_{i+k}]\}] &= \mathbb{E}[\#\{\mathcal{V}_i \cap [B_i]\}]p^k \\ &= \lambda p^k \quad \text{for all } i \geq 1 \text{ and } k \geq 0, \\ \mathbb{E}[\#\{\mathcal{V}_0 \cap [B_k]\}] &= \lambda p^k \sum_{m=0}^{\infty} p^m \\ &= \frac{1}{1-p} \lambda p^k \quad \text{for all } k \geq 0. \end{aligned}$$

Thus,

$$\begin{aligned} \mathbb{P}[H_i = 0] &\leq 1 \quad \text{for all } i \geq 0, \\ \mathbb{P}[H_i = k > 0] &= \mathbb{P}[\mathcal{V}_i \cap [B_{i+k}] \neq \emptyset \text{ and } \mathcal{V}_i \cap [B_{i+k+1}] = \emptyset] \\ &= \exp(-\lambda p^{k+1}) - \exp(-\lambda p^k) \quad \text{using } [B_{i+1}] \subset [B_i] \\ &\leq 1 - \exp(-\lambda(p^k - p^{k+1})) \\ &\leq \lambda p^k (1-p) \quad \text{for } i \geq 1. \end{aligned}$$

Similarly,

$$\begin{aligned} \mathbb{P}[H_0 = k > 0] &= \exp\left(-\frac{\lambda p^{k+1}}{1-p}\right) - \exp\left(-\frac{\lambda p^k}{1-p}\right) \\ &\leq \lambda p^k. \end{aligned}$$

Hence, for all $0 < a < 1/p$:

$$\mathbb{E}[a^{H_i}] \leq 1 + \sum_{k=1}^{\infty} \lambda p^k (1-p) a^k$$

$$\begin{aligned}
&= 1 + \lambda(1-p) \frac{ap}{1-ap} \quad \text{for all } i \geq 1, \\
(9) \quad \mathbb{E}[a^{H_0}] &\leq 1 + \sum_{k=1}^{\infty} \lambda p^k a^k \\
&= 1 + \lambda \frac{ap}{1-ap}, \\
(10) \quad \mathbb{E}[a^{I_n}] &\leq \mathbb{E}[a^{\sum_{i=0}^{n-1} H_i}] \vee 1 \\
&\leq \left(1 + \lambda(1-p) \frac{ap}{1-ap}\right)^n \frac{1 + ap(\lambda-1)}{1 + ap(\lambda(1-p) - 1)} \\
&\leq \left(1 + \lambda \frac{ap}{1-ap}\right)^n.
\end{aligned}$$

We now use the Markov inequality:

$$(11) \quad \mathbb{P}[I_n > \delta n] \leq \frac{\mathbb{E}[a^{I_n}]}{a^{\delta n}},$$

and optimize upon a . Exact optimization requires solving a degree-two equation and yields a cumbersome solution, so we shall only use here the solution for the second approximation when $\lambda = 1$, that is $a = \delta / ((1 + \delta)p)$, so that $ap / (1 - ap) = \delta$. Using (10), we get

$$\begin{aligned}
(12) \quad \mathbb{P}[I_n > \delta n] &\leq \frac{1 + \lambda ap / (1 - ap)}{1 + \lambda(1-p)ap / (1 - ap)} \left(1 + \lambda(1-p) \frac{ap}{1 - ap}\right)^n a^{-\delta n} \\
&= \frac{1 + \lambda\delta}{1 + \lambda(1-p)\delta} \left((1 + \lambda(1-p)\delta) \left(\frac{1 + \delta}{\delta}\right)^\delta p^\delta\right)^n \\
&\leq \left((1 + \lambda\delta) \left(\frac{1 + \delta}{\delta}\right)^\delta p^\delta\right)^n. \quad \square
\end{aligned}$$

The second lemma gives a guarantee that except on exceedingly rare events; no significant fraction of uniformly randomly oriented lines are clumped together in a small number of directions.

LEMMA 4.2. *Let (\mathcal{X}, d, μ) be a metric space with a probability measure μ , and such that for all positive and small enough ε , for any point x in \mathcal{X} , the volume of the ball is bounded in this way:*

$$(13) \quad c_1 \varepsilon^{d-1} \leq \mu[B(x, \varepsilon)] \leq c_2 \varepsilon^{d-1},$$

for c_1 and c_2 constants depending only on the space (\mathcal{X}, d, μ) .

Let $\alpha > \beta > \delta > 0$. Consider $\{s_i\}_{i \in I}$ a $n^{-\eta}$ -net of \mathcal{X} . Consider $\{x_j\}_{j \leq \alpha n}$ an random μ -i.i.d. points in \mathcal{X} .

Then there is no subset of βn points in $\{x_j\}$ that are all contained in at most δn balls of the net $B(s_i, n^{-\eta})$, except on an event of sub-exponential probability, at most $(Cn^{(\beta-\delta)(\eta(d-1)-1)})^{-n}$ with C depending only on α, β and δ, c_1 and c_2 .

Moreover, the projective space $(P\mathbb{R}^{d-1}, \theta, \mu_{d-1}^{(o)})$ satisfies the hypotheses for (\mathcal{X}, d, μ) . Here $\theta(l_1, l_2)$ is the angle between two lines, and $\mu_{d-1}^{(o)}$ is the natural probability measure on $P\mathbb{R}^{d-1}$, defined in Section 2.

PROOF. Since all the points in the $n^{-\eta}$ -net are in disjoint balls of radius $n^{-\eta}/2$, there are at most $c_3 n^{\eta(d-1)}$ points in the net, for n big enough. Now, with c_4, c_5, c_6 depending on α, β and δ :

$$\begin{aligned} & \mathbb{P}[\text{There are } \beta n \text{ points } x_j \text{ all contained in } \delta n \text{ balls } B(s_i, n^{-\eta}) \text{ of the net}] \\ & \leq \#\{\text{subsets of } \beta n \text{ points}\} \#\{\text{subsets of } \delta n \text{ balls}\} \\ & \quad \times \mathbb{P}[\beta n \text{ specific points are all contained in } \delta n \text{ specific balls}] \\ & \leq \binom{\alpha n}{\beta n} \binom{c_3 n^{\eta(d-1)}}{\delta n} (\delta n c_2 n^{-\eta(d-1)})^{\beta n} \\ & \leq 2^{\alpha n} (c_4 n^{\eta(d-1)-1})^{\delta n} (c_5 n^{1-\eta(d-1)})^{\beta n} \\ & = (c_6 n^{(\beta-\delta)(\eta(d-1)-1)})^{-n}. \end{aligned}$$

In the projective space, where points are seen as lines through the origin in \mathbb{R}^d , a ball of radius θ_0 is exactly a cone of aperture θ_0 . We recall formula (1) and $\theta/2 \leq \sin(\theta) \leq \theta$ for positive small θ , and we conclude that property (13) is indeed satisfied. \square

4.2. *Many directions.* Having many directions near a point x intuitively means that the lines used near the point have so many different unit vectors that the only way to touch all those lines (a *tour*) with a finite curve is by touching most of them near x .

DEFINITION 4.3. For a set of lines $\mathcal{L} = \{l_j\}_{j \in J}$ and a subset of the Euclidean space $X \subset \mathbb{R}^d$, a \mathcal{L} -tour in X is a curve f in X such that for all $j \in J$, there is a t_j such that $f(t_j) \in l_j$. If f is rectifiable, the tour is said to be finite; else it is infinite.

Recalling the notation \mathcal{L}_ξ for the support of ξ :

DEFINITION 4.4. A finite Π -path ξ has *many directions* near a point x if, for all $\varepsilon > 0$, all \mathcal{L}_ξ -tours in $\mathbb{R}^d \setminus B(x, \varepsilon)$ are infinite.

As a remark, this concept is only interesting in dimension at least three: in dimension two, a circle is usually a tour, and it is finite.

PROPOSITION 4.5. *Let two finite Π -paths ξ and η . If ξ has many directions near a point $x \in \mathbb{R}^d$, and its support is included in that of η , that is, $\mathcal{L}_\xi \subset \mathcal{L}_\eta$, then $x \in \eta$.*

PROOF. By Theorem 2.4, the finite Π -path η has finite Euclidean length. Moreover, $\mathcal{L}_\xi \subset \mathcal{L}_\eta$, so that η is a \mathcal{L}_ξ -tour in \mathbb{R}^d . Since ξ has many directions near x , there is no finite \mathcal{L}_ξ -tour in $\mathbb{R}^d \setminus B(x, \varepsilon)$, for any $\varepsilon > 0$. So that $B(x, \varepsilon) \cap \eta \neq \emptyset$. Any finite Π -path is closed in \mathbb{R}^d , hence $x \in \eta$. \square

LEMMA 4.6. *Let $d \geq 3$.*

Let l be a prescribed line independent of Π . Almost surely, for all $x \in l$, for any $y \notin l$, all geodesics g_{xy} have many directions near x .

PROOF. It is sufficient to show that the claim holds for all $x \in l \cap B(0, R)$, for all $R > 0$. It is also sufficient to work with a fixed ε , and prove that for any $y \notin l^\varepsilon$ the ε -widening of l , for any geodesic g_{xy} , all $\mathcal{L}_{g_{xy}}$ -tours on $\mathbb{R}^d \setminus B(x, \varepsilon)$ have infinite length.

Let $r_n = r_0/\alpha^n$ for $r_0 = \varepsilon$ and an $\alpha > 1$ big enough to be determined later. We consider one-dimensional internal $\frac{r_n}{4}$ -nets N_n of $B(0, R) \cap l$.

In particular, there are at most $\frac{4R}{r_n} + 1$ points in N_n .

Now, for any point x_n in N_n , we may build a set of nested balls $\{B_i\}_{i \leq n}$ depending on x_n , with the following properties:

- The ball B_n is centred on x_n .
- All balls $B_i = B(x_i, r_i)$ are centred on a point x_i in the net N_i .
- The centres lie deep inside the previous ball, that is $x_i \in B(x_{i-1}, \frac{r_{i-1}}{4})$.
This stems from the fact that N_{i-1} is an $\frac{r_{i-1}}{4}$ -net.

We also use the notation of Lemma 4.1 for v_i and \mathcal{V}_i . We have to choose a good speed v_0 .

We then show that the nested balls have the following properties, with a T to be determined later, except on an event of probability $o(r_n^{-1})$:

1. There are at least $\frac{2n}{5}$ balls B_i that no line faster than v_{i-1} hits.
2. There are at least $\frac{5n}{6}$ indices i such that the time diameter of $B(x_i, \frac{7r_i}{8}) \setminus B(x_i, \frac{r_i}{2})$ on $\Pi_{[B_i] \setminus [B_{i+1}]}$ is less than $T\alpha^{-i(\gamma-d)/(\gamma-1)}$.
3. There are at least $\frac{5n}{6}$ balls B_i that are hit by at most τ lines of speed between v_i and v_{i-1} , for some fixed τ . Moreover, all those lines have independent, uniformly random directions.

The T will yield the v_0 we need to continue the proof, that is,

$$(14) \quad v_0 = \frac{3r_0}{8T}.$$

We deal with these properties in reverse order, and first consider property 3.

Since the sets of lines \mathcal{V}_i are disjoint, the events that more than τ lines in \mathcal{V}_i hit B_i are mutually independent (in i), as are their directions. Moreover, since the B_i are balls, the direction of the lines of the isotropic Poisson line process that hit it are uniformly random.

So that the number X_n of such events is a binomial random variable $B(n, q)$ where q is the probability of a single event. The Chernoff bound for a binomial is, for $\delta > q$,

$$\mathbb{P}[X_n > \delta n] \leq \left(\left(\frac{q}{\delta} \right)^\delta \left(\frac{1-q}{1-\delta} \right)^{1-\delta} \right)^n.$$

Here, it suffices to take $\delta = \frac{1}{6}$. For α big enough, if, for example, we take $q \leq \alpha^{-7}$, the above bound is negligible with respect to α^{-n} .

Now the probability q of a single event is the probability that a Poisson random variable with parameter not depending on i is bigger than τ . We then just choose τ so that $q \leq \alpha^{-7}$.

Now for property 2.

Since the sets of lines $[B_i] \setminus [B_{i+1}]$ are disjoint, each of the events that the time diameter of $B(x_i, \frac{7r_i}{8}) \setminus B(x_i, \frac{r_i}{2})$ on $\Pi_{[B_i] \setminus [B_{i+1}]}$ is less than $T\alpha^{-i(\gamma-d)/(\gamma-1)}$ are independent. Arguing as for property 3, we merely have to choose T such that the probability q of a single event is less than α^{-7} .

Now, by scaling, the sets $A_i = B(x_i, \frac{7r_i}{8}) \setminus B(x_i, \frac{r_i}{2})$ may all be covered by the same number \hat{N} of balls with radius $\frac{r_i}{8}$, and centres in A_i . Moreover, A_i is connected. Now the $\frac{r_i}{8}$ -widening of A_i is included in B_i , and since $x_{i+1} \in B(x_i, \frac{r_i}{4})$, we know that x_{i+1} is at distance at least $\frac{1}{8}$ of this widening. So that the maximum solid angle of B_{i+1} viewed from any point of the widening is a decreasing function of α , hitting zero when α goes to infinity. Thus, for α big enough, we may apply Lemma 3.1 with $\Omega < \Omega_{\max}$. Replacing ε in bound (3) with $1/(\varepsilon_{\max}\alpha^{-7})$ to ensure $q \leq \alpha^{-7}$, we find that property 2 is ensured if we choose

$$\begin{aligned} T &= \hat{N}T_1 \left(\frac{r_0}{8} \right)^{(\gamma-d)/(\gamma-1)} (\ln(\alpha^7/\varepsilon_{\max}))^{1/(\gamma-1)} \\ &= O(\ln^{1/(\gamma-1)} \alpha). \end{aligned}$$

This choice of T ensures that $v_0 = O(\ln^{-1/(\gamma-1)} \alpha)$.

As for property 1, we apply Lemma 4.1.

We substitute $\delta = \frac{3}{5}$ in equation (8), and use $p = \alpha^{1-d} \leq \alpha^{-2}$ —since $d \geq 3$ —and $\lambda = O(v_0^{1-\gamma}) = O(\ln \alpha)$. We obtain

$$\begin{aligned} & \mathbb{P} \left[\text{For less than } \frac{2n}{5} \text{ indices } i, \text{ no line faster than } v_{i-1} \text{ hits the ball } B_i \right] \\ & \leq (c \ln(\alpha) \alpha^{-6/5})^n \\ & = o(\alpha^{-n}). \end{aligned}$$

Let us now consider a geodesic g_{xy} from a point y outside B_0 to a point x inside B_n . Since the balls are nested, they are all crossed by the geodesic. Even the sets $A_i = B(x_i, \frac{7r_i}{8}) \setminus B(x_i, \frac{r_i}{2})$ introduced in the proof of property 2 are all crossed, that is we must pass from the spherical boundary $S(x_i, \frac{7r_i}{8})$ to the smaller boundary $S(x_i, \frac{r_i}{2})$.

If the three properties are satisfied, then there are at least $\frac{n}{15}$ indices i for which the conditions are simultaneously satisfied. For such an i , by property 2 the geodesic will go from $S(x_i, \frac{7r_i}{8})$ to $S(x_i, \frac{r_i}{2})$ in time at most $T\alpha^{-i(\gamma-d)/(\gamma-1)}$. Since the two boundaries are $\frac{3r_i}{8}$ apart, the geodesic must use a line with speed more than $\frac{3r_i}{8T\alpha^{-i(\gamma-d)/(\gamma-1)}} = v_0\alpha^{-i(d-1)/(\gamma-1)} = v_i$ within A_i . Now, $A_i \subset B_i$ and, by property 1, there is no line faster than v_{i-1} in B_i . So that the geodesic must use a line in $\mathcal{V}_i \cap [B_i]$, whose cardinal is less than τ by property 3. Since the v_i are disjoint, we have proved that the geodesic must use at least $\frac{n}{15}$ distinct lines among a set of size at most τn of lines with uniformly random direction.

We may then apply Lemma 4.2.

We take $1 > \eta > 1/(d-1)$ and $\delta = 1/20$. With probability $1 - O(n^{-cn})$, all geodesics from a point outside B_0 to a point inside B_n must use at least $n/20$ lines (depending on the geodesic), each with a direction in a different ball of a $n^{-\eta}$ -net of the projective space. Since there are at most a constant number c_1 of points in a $n^{-\eta}$ -net at distance less than $3n^{-\eta}$ from a given point, we may choose $n/(20c_1)$ of those lines, so that each pair of them makes an angle at least $n^{-\eta}$.

Let us consider a fixed $r_0 = \varepsilon$. Since $d(x_i, x_{i-1}) \leq \frac{r_{i-1}}{4}$ and $x \in B(x_n, r_n)$, and since $r_i = \varepsilon\alpha^{-i} = o(\varepsilon n^{-\eta})$ for $i > c_2 \ln n$, we know that $B_i \subset B(x, \varepsilon n^{-\eta}/3)$ for $i > c_2 \ln n$. Among our $n/(20c_1)$ lines, at most τ hit each B_i . Hence, up to removing $c_3 \ln n$ of our $n/(20c_1)$ lines, all those lines hit the ball $B(x, \varepsilon n^{-\eta}/3)$. So that, by elementary geometry illustrated in Figure 3, for any two lines l_1 and l_2 in our collection, no point of $l_1 \setminus B(x, \varepsilon)$ is closer to a point of $l_2 \setminus B(x, \varepsilon)$ than $\varepsilon n^{-\eta}/4$.

We have thus proved that for any geodesic g_{xy} with $x \in B_n$ and $y \notin B_0$, any $\mathcal{L}_{g_{xy}}$ -tour in $\mathbb{R}^d \setminus B(x, \varepsilon)$ must contain $c_4 n$ points that are $c_5 n^{-\eta}$ apart pairwise. Hence, it has length at least $c_6 n^{1-\eta}$, going to infinity with n .

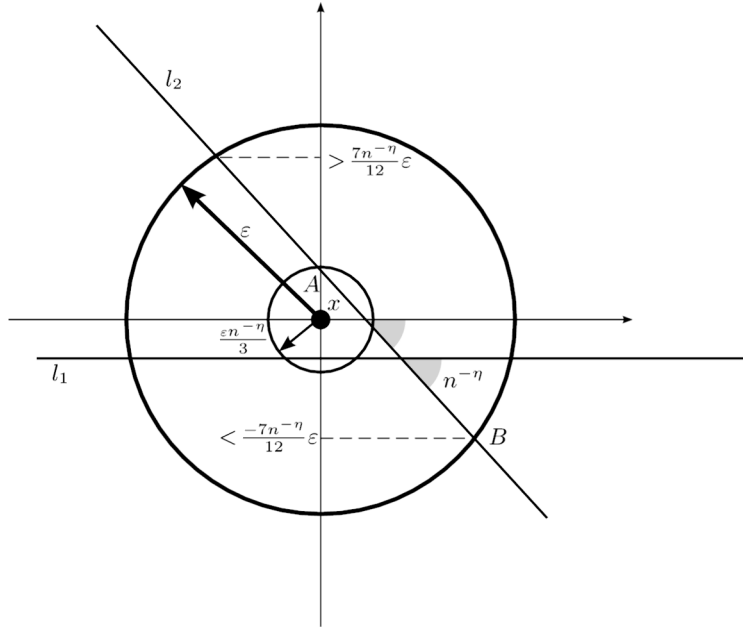

FIG. 3. We project on the vector space spanned by l_1 and l_2 , with l_1 parallel to the first coordinate and x as the origin. All points of l_1 then have second coordinate at most $n^{-\eta}\varepsilon/3$ in absolute value. On the other hand, let A be a point in $l_2 \cap B(x, n^{-\eta}\varepsilon/3)$ and B a point in $l_2 \setminus B(x, \varepsilon)$. Then the vector \overline{AB} has absolute second coordinate at least $(\varepsilon - n^{-\eta}\varepsilon/3) \sin(n^{-\eta}) > \frac{11}{12}\varepsilon n^{-\eta}$ for large n , so that B has absolute second coordinate at least $\frac{7}{12}\varepsilon n^{-\eta}$.

All those properties were obtained except on a set of probability $o(\alpha^{-n})$. Since the net N_n has cardinal of order α^n , this is true simultaneously for all sets of nested balls built on all the points x_n in N_n , except on an event of probability ε_n going to zero.

Letting n go to infinity yields the lemma. \square

4.3. Geodesics use the same lines.

THEOREM 4.7. *For all x and y in \mathbb{R}^d , almost surely all geodesics g_{xy} are supported on exactly the same lines.*

PROOF. A similar result is used during the proof of Theorem 4.4 in Kendall's (2015) article. The idea of the proof is to "slow down" the lines not used by a specific geodesic. Then all geodesics that use one of those lines become slower and are no longer geodesics. The set of slowed speeds has infinite measure relative to the initial speeds.

Almost surely, there exists a finite R such that all geodesics from x to y are included in $B(0, R)$, by Theorem 2.6 of Kendall. Almost surely, for any

R , there are countably many lines intersecting $B(0, R)$, all with different speeds $v_1 > v_2 > \dots$ (the information here is that there is a measurable order-preserving bijection from \mathbb{N} to the inverse line speeds). We then write l_i for the line with speed v_i .

Let $i \in \mathbb{N}$ and let us fix all the other speeds v_j for $j \neq i$. Let us suppose there is a speed v_i^- between v_{i-1} and v_{i+1} such that if $v_i = v_i^-$, then there are at least two geodesics g_{xy}^i and g_{xy}^{-i} from x to y , one of which is supported by l_i , and the other not. That is $l_i \sqsubset g_{xy}^i$ and $l_i \not\sqsubset g_{xy}^{-i}$.

Now, the time length of a path not supported by l_i does not depend on v_i . So that g_{xy}^{-i} is the fastest of these paths for all v_i , with constant time. On the other hand, by decomposition (2), the time length of g_{xy}^i is decreasing in v_i . Hence, if $v_i > v_i^-$, all geodesics from x to y are supported by l_i . Conversely, if $v_i < v_i^-$, no path supported by l_i is a geodesic from x to y . Indeed, such a path would be as fast as g_{xy}^{-i} at speed v_i , hence faster at speed v_i^- .

So that, when the other speeds are fixed, there is at most one value v_i^- of v_i such that l_i is in the support of some geodesic from x to y and not in the support of another such geodesic.

Now, we may disintegrate the measures on the line speeds. For almost all fixed line speeds for all lines except l_i , the measure μ_i for v_i has a density (namely, it is proportional to $v_i^{-\gamma} \mathbf{1}_{v_{i-1} \leq v_i \leq v_{i+1}}$). Hence, $\mu_i(\{v_i^-\}) = 0$. So that almost surely, either $l_i \sqsubset g$ for all geodesics g from x to y , or $l_i \not\sqsubset g$ for any such geodesic. This is true for all lines l_i , completing the proof. \square

4.4. *Almost sure uniqueness.* We may now state this section's main result.

THEOREM 4.8. *In dimension $d \geq 2$, for all x and y in \mathbb{R}^d , almost surely there is a unique geodesic g_{xy} from x to y .*

PROOF. Kendall (2015) proved the dimension 2 case in Theorem 4.4. We then assume from here on that $d \geq 3$.

Consider any line $l \in \Pi$. We apply a Palm distribution argument: since Π is a Poisson process, $\Pi \setminus \{l\}$ still has the same distribution as Π . So that almost surely, by Lemma 4.6, all geodesics on $\Pi \setminus \{l\}$ with an endpoint $z \in l$ have many directions near z . Since the lines are countable, this is true for all lines simultaneously.

The rigorous way of writing the former paragraph is through Slivnyak–Mecke formula [originally proved by Slivnyak (1962); see, e.g., Møller and Waagepetersen's (2003) book, Theorem 3.2, for a modern treatment]. A Poisson point process X with intensity μ takes value in the set of locally finite point configurations N_{lf} . For any nonnegative measurable

function h on $\mathbb{R}^d \times N_{lf}$, we have

$$\mathbb{E} \left[\sum_{x \in X} h(x, X \setminus \{x\}) \right] = \int_{\mathbb{R}^d} \mathbb{E}[h(x, X)] d\mu(x).$$

We apply the formula with the underlying point process for Π , so that $x = (l, v)$ are marked lines. The function h is the indicator function

$$h((l, v), \Pi) = \begin{cases} 1, & \text{if } \exists z \in l, y \notin l, g_{zy} \text{ } \Pi\text{-geodesic such that} \\ & g_{zy} \text{ does not have many directions near } z, \\ 0, & \text{otherwise.} \end{cases}$$

Lemma 4.6 then ensures that the expectation in the integrand in the right-hand side is uniformly zero, so that, almost surely, for all $l \in \Pi$, all geodesics on $\Pi \setminus \{l\}$ with an endpoint $z \in l$ have many directions near z .

Let g_{xy} be a geodesic from x to y . Let $\{z_i\}$ be the set of endpoints of all the segments of the geodesic g_{xy} except x and y . For any z_i , since it is a segment endpoint (on line l), there is a u such that g_{uz_i} or $g_{z_i u}$ is included in g_{xy} , and such that l is not in the support of this sub-geodesic. Hence, this sub-geodesic is also a geodesic in $\Pi \setminus \{l\}$, and has many directions near z_i . A fortiori, g_{xy} has many directions near z_i . Moreover, by Lemma 4.7 almost surely all other geodesics from x to y have the same support. Hence, all these geodesics include all the segment endpoints of all the geodesics from x to y .

Now two geodesics from x to y must pass through the same points in the same order: indeed if $g_{xy}^2 = g_{xa}^2 g_{ab}^2 g_{by}^2$ and $g_{xy}^2 = g_{xb}^2 g_{ba}^2 g_{ay}^2$, then $g_{xa}^1 g_{ay}^2$ or $g_{xb}^2 g_{by}^1$ would be shorter than both.

So that all geodesics from x to y pass through their segment endpoints in the same order, so they are the same. \square

A byproduct of the proof is the following remark.

COROLLARY 4.9. *Let $d \geq 3$. Almost surely, for any point x not on a line of Π , that is $x \notin \mathcal{S}$, all geodesics containing x have many directions near x .*

PROOF. We use the step in the former proof, that almost surely, for all $l \in \Pi$, all geodesics on $\Pi \setminus \{l\}$ with an endpoint $z \in l$ have many directions near z .

For any ε , since $x \notin \mathcal{S}$, the geodesic to x will leave a line of Π at a point $z \in B(x, \varepsilon/2)$. Now the restriction of the geodesic to g_{zx} has many directions near z . Since $B(z, \varepsilon/2) \subset B(x, \varepsilon)$, g has also many directions near x . \square

5. Geodesic length has finite expectation. This is property 3 of a SIRS.

THEOREM 5.1. *Let $x, y \in \mathbb{R}^d$. Then the Euclidean length of the Π -geodesic between x and y has finite expectation*

$$\mathbb{E}[L_{xy}] < \infty.$$

PROOF. For any r , any Π -path containing x whose Euclidean length is more than r has to intersect $B(x, r)$ on a length at least r . Hence, it must spend time at least $r/v_{\max}(B(x, r))$ in that ball. If the geodesic g_{xy} has Euclidean length L_{xy} and time length T_{xy} , we thus obtain the constraint

$$(15) \quad v_{\max}(B(x, r)) \geq r/T_{xy} \quad \text{for all } r \leq L_{xy}.$$

By equation (3) of Theorem 3.1, there is a T such that with probability at least $1 - 2^{-(n+1)}$

$$(16) \quad T_{xy} \leq (n+1)^{1/(\gamma-1)}T \hat{=} T_n.$$

We now consider a collection of radii

$$r_l = 2^l r_0$$

for l between 0 and m , with r_0 and m to be chosen later, possibly depending on n , but independent of Π .

If $L_{xy} > r_m$, then $L_{xy} > r_l$ for all $l \in [0, m]$, so that constraint (15) must be satisfied for each r_l . In particular, on the event (16), the following constraint is satisfied for all $l \in [0, m]$:

$$(17) \quad v_{\max}(B(x, r_l)) \geq r_l/T_n \hat{=} v_l.$$

We again drop the dependence on n in the notation of v_l , and v_l is independent of Π .

These constraints are simultaneously satisfied if and only if there is a strictly increasing sequence of $(1+k)$ integers $0 = l_0, l_1, \dots, l_k$ between 0 and m such that

$$\begin{aligned} v_{l_{i+1}} &> v_{\max}(B(x, r_{l_i})) \geq v_{l_{i+1}-1} && \text{if } i < k, \\ v_{\max}(B(x, r_{l_k})) &\geq v_m. \end{aligned}$$

We define the following events for all $i \in [0, m]$, with the conventions $l_{k+1} = m+1$ and $r_{l_{-1}} = 0$:

$$\begin{aligned} A_i &= \{v_{\max}(B(x, r_{l_i})) \geq v_{l_{i+1}-1}\}, \\ B_i &= \{v_{l_{i+1}} > v_{\max}(B(x, r_{l_i})) \geq v_{l_{i+1}-1}\}, \\ D_i &= \{v_{\max}([B(x, r_{l_i})] \setminus [B(x, r_{l_{i-1}})]) \geq v_{l_{i+1}-1}\}. \end{aligned}$$

Notice that the events do not depend only on i , but on the whole sequence of l_i . Notation is easier this way. In particular, the former paragraph reads

$$(18) \quad \mathbb{P}[L_{xy} > r_m | T_{xy} \leq T_n] \leq \sum_{k=0}^m \sum_{0=l_0 < \dots < l_k \leq m} \mathbb{P}[B_0 \cap B_1 \cap \dots \cap B_{k-1} \cap A_k].$$

Let us consider the filtration generated by the lines intersecting $B(x, r)$ for increasing r , that is $\mathcal{F}_r = \sigma(\Pi_{[B(x, r)]})$. Then A_i , B_i and D_i are all $\mathcal{F}_{r_{l_i}}$ -measurable, and D_i is independent of $\mathcal{F}_{r_{l_{i-1}}}$.

Moreover, the difference between A_i and D_i is only on the event that there is a line faster than $v_{l_{i+1}-1}$ hitting $B(x, r_{l_{i-1}})$. Since $l_{i+1} - 1 \geq l_i$, this never happens under B_{i-1} . So that $A_i \cap B_{i-1} = D_i \cap B_{i-1}$. From this, we deduce

$$(19) \quad \begin{aligned} \mathbb{P}[B_i | B_0, \dots, B_{i-1}] &\leq \mathbb{P}[A_i | B_0, \dots, B_{i-1}] && \text{since } B_i \subset A_i \\ &= \mathbb{P}[D_i | B_0, \dots, B_{i-1}] && \text{since } A_i \cap B_{i-1} = D_i \cap B_{i-1} \\ &= \mathbb{P}[D_i] && \text{since } D_i \text{ indep. of } B_j \text{ for } j < i \\ &\leq \mathbb{P}[A_i] && \text{since } D_i \subset A_i. \end{aligned}$$

Recall that the number of lines faster than v hitting a ball of radius r is a Poisson variable with parameter $cr^{d-1}v^{-(\gamma-1)}$, with $c = \mu_d([B(0, 1)])$. We may then compute

$$(20) \quad \begin{aligned} \mathbb{P}[A_i] &= 1 - \exp(-cr_{l_i}^{d-1}v_{l_{i+1}-1}^{-(\gamma-1)}) \\ &\leq cr_{l_i}^{d-1}v_{l_{i+1}-1}^{-(\gamma-1)} \\ &= cr_{l_i}^{d-1}2^{-(\gamma-1)(l_{i+1}-l_i-1)}v_{l_i}^{-(\gamma-1)} \\ &= 2^{-(\gamma-1)(l_{i+1}-l_i-1)}cr_{l_i}^{d-\gamma}T_n^{\gamma-1} \\ &\leq 2^{-(\gamma-1)(l_{i+1}-l_i-1)}cr_0^{d-\gamma}T_n^{\gamma-1} && \text{since } r_0 \leq r_{l_i} \\ &= 2^{-(\gamma-1)(l_{i+1}-l_i)}p(r_0) && \text{with} \\ p(r_0) &= 2^{\gamma-1}cr_0^{d-\gamma}T_n^{\gamma-1}. \end{aligned}$$

Recalling the convention $l_{k+1} = m + 1$, we obtain

$$\begin{aligned} &\mathbb{P}[B_0 \cap B_1 \cap \dots \cap B_{k-1} \cap A_k] \\ &\leq \mathbb{P}[B_0] \mathbb{P}[B_1 | B_0] \dots \mathbb{P}[A_k | B_0, B_1, \dots, B_{k-1}] \\ &\leq \prod_{i=0}^k \mathbb{P}[A_i] && \text{by (19)} \\ &\leq \prod_{i=0}^k 2^{-(\gamma-1)(l_{i+1}-l_i)}p(r_0) && \text{by (20)} \end{aligned}$$

$$= 2^{-(\gamma-1)(m+1)} p(r_0)^{k+1}.$$

Substituting into bound (18), we obtain

$$\begin{aligned} \mathbb{P}[L_{xy} > r_m | T_{xy} \leq T_n] &\leq \sum_{k=0}^m \sum_{0=l_0 < \dots < l_k \leq m} 2^{-(\gamma-1)(m+1)} p(r_0)^{k+1} \\ (21) \qquad \qquad \qquad &= \sum_{k=0}^m \binom{m}{k} 2^{-(m+1)(\gamma-1)} p(r_0)^{k+1} \\ &= 2^{-(m+1)(\gamma-1)} p(r_0) (1 + p(r_0))^m \end{aligned}$$

$$(22) \qquad \qquad \qquad \leq (2^{-(\gamma-1)} (1 + p(r_0)))^{m+1}.$$

Let $\kappa < \gamma - 1$. We now choose our free parameters:

$$r_0 = \left(\frac{2^{\gamma-1} c T^{\gamma-1}}{2^{\gamma-1-\kappa} - 1} \right)^{1/(\gamma-d)},$$

so that

$$\begin{aligned} 1 + p(r_0) &= 2^{\gamma-1-\kappa}, \\ m &= \lfloor (n+1)/\kappa \rfloor. \end{aligned}$$

Substituting into bound (22), we get

$$\begin{aligned} \mathbb{P}[L_{xy} > r_m | T_{xy} \leq T_n] &\leq 2^{-(m+1)\kappa} \\ &\leq 2^{-(n+1)}. \end{aligned}$$

Since $\mathbb{P}[T_{xy} > T_n] \leq 2^{-(n+1)}$, we have thus proved that with probability at least $1 - 2^{-n}$, the Euclidean length is bounded by

$$\begin{aligned} L_{xy} &\leq r_m \\ &= 2^{(n+1)/\kappa} (n+1)^{1/(\gamma-d)} C, \end{aligned}$$

where C is a positive constant depending on T and κ , but not on n .

Thus, L_{xy} has a δ -moment for all $\delta < \kappa$. Indeed,

$$\begin{aligned} \mathbb{E}[L_{xy}^\delta] &\leq \sum_{n=0}^{\infty} 2^{-n} (2^{(n+1)/\kappa} (n+1)^{1/(\gamma-d)} C)^\delta \\ &\leq \sum_{n=0}^{\infty} 2^{(\delta/\kappa-1)n} O(n^{\delta/(\gamma-d)}) \\ &< \infty \quad \text{if } \delta < \kappa. \end{aligned}$$

Since κ is only constrained by $\kappa < \gamma - 1$, we have a δ -moment for all $\delta < \gamma - 1$. Since $\gamma > d \geq 2$, this completes the proof. \square

REMARK 5.1. The main part of the proof is really just saying that the Euclidean diameter of a Π -ball has finite mean. Together with Theorem 3.1, this implies that the random metric space generated by the Π -length is almost surely homeomorphic to \mathbb{R}^d .

Notice that for κ close to $\gamma - 1$, the main term in the sum (21) is the one for $k = 0$. In other words, it is easier to have one single extremely fast line close to x than to have many successively faster lines, if we want to be abnormally fast at each distance of x .

A first way to improve on the moments of L_{xy} starts with noticing that if we use a line to go far away very fast, we need to use another line to come back, since a geodesic never crosses itself.

More precisely, the author conjectures that the structure yielding long geodesics with highest probability is the following: a line with speed at least $2r/T_{xy}$ hits $B(x, \varepsilon)$, another hits $B(y, \varepsilon)$ and they hit a common ε -ball at distance r . Since the two first events have probability in $r^{-(\gamma-1)}$ and the other in $r^{-(d-1)}$, we would conclude that $\mathbb{E}[L_{xy}^{2\gamma+d-3}] = \infty$, but $\mathbb{E}[L_{xy}^\delta] < \infty$ for all $\delta < 2\gamma + d - 3$.

6. Finite intensity of long-distance network. We now turn to property 4 of a SIRS, that is their key property.

Intuitively, this means that the SIRS contains “highways.” If we look at all the geodesics simultaneously, truncating each geodesic by deleting balls around its endpoints, their total length in each compact set is finite: the geodesics largely re-use the same segments in each region. Contrast with the Euclidean case where the whole space is used.

In our context, we have to prove that the intensity $p(1)$ of the following long-distance network \mathcal{F} is finite: let $\{\Xi_n, n \in \mathbb{N}^*\}$ be a collection of Poisson processes on \mathbb{R}^d with intensity n times Lebesgue, all independent from Π , and coupled so that $\Xi_n \subset \Xi_{n+1}$. Write $\Xi = \bigcup_{n \in \mathbb{N}^*} \Xi_n$. Then

$$\mathcal{F} = \bigcup_{x, y \in \Xi} (g_{xy} \setminus (B(x, 1) \cup B(y, 1))).$$

Notice that almost surely g_{xy} is unique for all x and y , since the dense point set Ξ is countable.

By translational invariance, it is enough to prove that the intersection of \mathcal{F} with a given ball has finite mean Hausdorff measure of dimension 1. Indeed, if $\ell = m_1(\mathcal{F} \cap B(x, r))$, then $\mathbb{E}[\ell] = \frac{\omega_{d-1} r^{d-1}}{2} p(1)$. Notice that scale equivariance yields similar results if the long-distance network \mathcal{F} is defined by removing balls of any fixed radius instead of radius 1.

The main argument relies on the pigeon-hole principle: a geodesic getting close to a prescribed point must use one of a very few fast lines close to that point, and must use them again to draw away. And by uniqueness of

geodesics, two geodesics with two common points must agree between those points.

THEOREM 6.1. *Let $\gamma > d \geq 2$. With the above notation, let $\ell = m_1(\mathcal{F} \cap B(0, \frac{1}{3}))$ be the length of the long-distance network in $B(0, \frac{1}{3})$. For $\varepsilon < \varepsilon_{\max}$, with probability at least $1 - \varepsilon$, this length is less than $C(\ln(C_1/\varepsilon))^2$, for constants ε_{\max} , C and C_1 depending only on γ and d . Consequently, there is a finite moment of exponential form: for any $\delta < \sqrt{C}$,*

$$(23) \quad \mathbb{E}[\exp(\delta\sqrt{\ell})] < \infty.$$

In particular, ℓ has finite mean.

PROOF. Since Ξ is countable, by Theorem 4.8, almost surely all geodesics between its points are unique. In the proof, we only consider such geodesics and sub-geodesics, so that we assume uniqueness.

Consider the balls $B(0, \frac{1}{3})$ and $B(0, \frac{2}{3})$. We call their set difference $B(0, \frac{2}{3}) \setminus B(0, \frac{1}{3})$ the *border*.

Now if a point $x \in B(0, \frac{2}{3})$, then $B(0, \frac{1}{3}) \subset B(x, 1)$. Hence, geodesics with an endpoint in $B(0, \frac{2}{3})$ make no contribution to ℓ . We have

$$\ell \leq m_1 \left(\bigcup_{x,y \in \Xi \setminus B(0, 2/3)} \left(g_{xy} \cap B\left(0, \frac{1}{3}\right) \right) \right).$$

Hence, geodesics g_{xy} making contributions to ℓ are structured in the following way, illustrated in Figure 4.

- They hit $B(0, \frac{2}{3})$ for the first time at point s on the corresponding sphere.

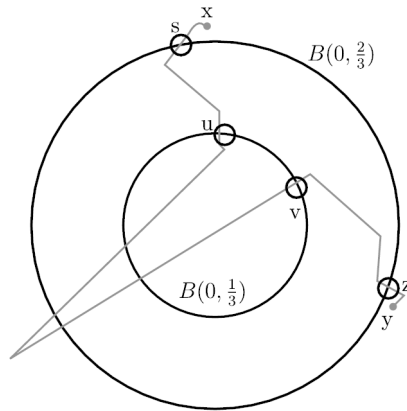

FIG. 4. *The geodesic from x to y hits $B(0, \frac{2}{3})$ for the first time at s and the last time at z . It hits $B(0, \frac{1}{3})$ for the first time at u and the last time at v .*

- Then they hit $B(0, \frac{1}{3})$ for the first time at point u on the corresponding sphere.
- Then they hit $B(0, \frac{1}{3})$ for the last time at point v on the corresponding sphere.
- Then they hit $B(0, \frac{2}{3})$ for the last time at point z on the corresponding sphere.

In particular, the contribution to ℓ is included in the sub-geodesic g_{uv} .

Now, uniformly on x and y , the time T_{sz} between s and z is bounded by the time diameter of $B(0, \frac{2}{3})$. So that, by Theorem 3.1, with probability $1 - \varepsilon/2$, we have

$$(24) \quad \begin{aligned} T_{sz} &\leq T_\varepsilon \\ &\hat{=} T_{2/3,1} \left(\ln \frac{2}{\varepsilon \cdot \varepsilon_{\max}} \right)^{1/(\gamma-1)}. \end{aligned}$$

We call *fast lines* the lines faster than $v_\varepsilon = 1/(6T_\varepsilon)$. Conversely, lines slower than v_ε are *slow lines*. We write $\mathcal{V}_\varepsilon = \mathcal{S}_{v_\varepsilon} \cap B(0, \frac{2}{3})$ for the intersection of all those fast lines with the ball $B(0, \frac{2}{3})$.

The number of fast lines hitting $B(0, \frac{2}{3})$ is a Poisson variable with parameter $\lambda_\varepsilon = \frac{\omega_{d-1}(2/3)^{d-1}}{2v_\varepsilon^{\gamma-1}} = C_2 \ln(C_1/\varepsilon)$ for explicit constants C_1 and C_2 , with $C_1 = 2/\varepsilon_{\max} \geq 2$. We recall that the moment generating function of such a Poisson variable X is $\mathbb{E}[e^{tX}] = \exp(\lambda_\varepsilon(e^t - 1))$, and use Chernoff bound to get

$$\begin{aligned} \mathbb{P}[X \geq C_3 \lambda_\varepsilon] &\leq e^{\lambda_\varepsilon(e^{C_3} - 1)} e^{-t C_3 \lambda_\varepsilon} \\ &= \exp(\lambda_\varepsilon(C_3 - 1 - C_3 \ln C_3)) \quad \text{with } e^t = C_3 \\ &= \left(\frac{C_1}{\varepsilon} \right)^{C_2(C_3 - 1 - C_3 \ln C_3)} \\ &\leq \frac{\varepsilon}{2}, \end{aligned}$$

with C_3 chosen big enough to have $C_2(C_3 - 1 - C_3 \ln C_3) \leq -1$.

Hence, with probability at least $1 - \frac{\varepsilon}{2}$, there are at most $C_3 \lambda_\varepsilon$ fast lines hitting $B(0, \frac{2}{3})$. With probability at least $1 - \varepsilon$ both this event and $T_{sz} \leq T_\varepsilon$ are true. We assume both from now on.

Since $T_{sz} \leq T_\varepsilon$, the intersection of g_{sz} with slow lines has length at most $v_\varepsilon/T_\varepsilon = \frac{1}{6}$.

So that, since s and u (resp., v and z) are at least $\frac{1}{3}$ apart, the geodesic must have fast segments for length at least $\frac{1}{6}$ between s and u (resp., v and z), that is,

$$\begin{aligned} m_1(\mathcal{V}_\varepsilon \cap g_{su}) &\geq \frac{1}{6}, \\ m_1(\mathcal{V}_\varepsilon \cap g_{vz}) &\geq \frac{1}{6}. \end{aligned}$$

Now

$$\begin{aligned} m_1(\mathcal{V}_\varepsilon) &\leq \#\{\text{fast lines}\} \cdot \text{Diam}\left(B\left(0, \frac{2}{3}\right)\right) \\ &\leq \frac{4C_3\lambda_\varepsilon}{3} \\ &= C_4 \ln\left(\frac{C_1}{\varepsilon}\right), \end{aligned}$$

so that

$$\frac{m_1 \otimes m_1(\mathcal{V}_\varepsilon \otimes \mathcal{V}_\varepsilon)}{m_1 \otimes m_1(g_{su} \cap \mathcal{V}_\varepsilon \otimes g_{vz} \cap \mathcal{V}_\varepsilon)} \leq C_5 \left(\ln \frac{C_1}{\varepsilon}\right)^2.$$

Hence, by the pigeon-hole property as illustrated in Figure 5, we may find a maximal family $\{g^i\}$ of at most $(C_5(\ln \frac{C_1}{\varepsilon})^2 + 1)$ geodesics such that:

- g^i is a geodesic between x^i and y^i in $\Xi \setminus B(0, \frac{2}{3})$, passing through s^i , u^i , v^i and z^i defined as for s, u, v and z above.
- Any geodesic g_{xy} contributing to ℓ crosses one of the g^i when first and last crossing the border, that is, there are points t and w such that $t \in g_{s^i u^i} \cap g_{su}$ and $w \in g_{v^i z^i} \cap g_{vz}$.

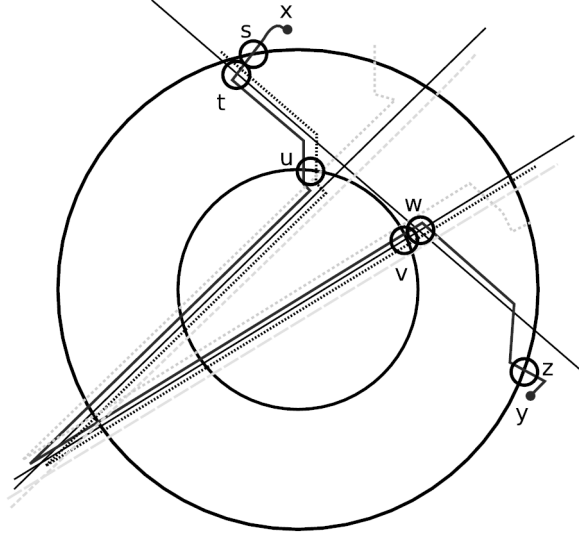

FIG. 5. Close parallel curves in the figure agree. They are separated to make the figure more readable. The three thin black lines are the fast lines. The light dashed lines and black dotted curves are a family of geodesics $\{g^i\}$. The solid curve connecting x and y is the geodesic g_{xy} . The geodesic g_{xy} has a common point t with the black dotted geodesic on a fast (black) line when first crossing the border, and another w when last crossing the border. Hence, they agree between u and v . Any other geodesic contributing to ℓ would meet one of the geodesics in the family $\{g^i\}$ in the same way.

By uniqueness of geodesics, g^i and g_{xy} coincide on g_{tw} . In particular, they coincide on g_{uv} . Hence, the intersection $\mathcal{F} \cap B(0, \frac{1}{3})$ is included in the finite number of geodesics $g_{u^i v^i}$. We may then conclude by separating contributions from fast and slow lines:

$$\begin{aligned} \ell &\leq \sum_i m_1(g_{u^i v^i}) \\ &\leq m_1(\mathcal{V}_\varepsilon) + \sum_i m_1(g_{u^i v^i} \cap (\Pi \setminus \mathcal{V}_\varepsilon)) \\ &\leq C_4 \ln\left(\frac{C_1}{\varepsilon}\right) + \left(C_5 \left(\ln \frac{C_1}{\varepsilon}\right)^2 + 1\right) \cdot \frac{1}{6} \\ &\leq C \left(\ln \frac{C_1}{\varepsilon}\right)^2. \quad \square \end{aligned}$$

THEOREM 6.2. *The network \mathcal{N} made of the time geodesics is a SIRS N .*

PROOF. Property 1 of a SIRS N is a consequence of almost sure uniqueness of geodesics between two points, that is Theorem 4 in dimension at least 3, and Theorem 4.4. in Kendall's (2015) article in dimension 2.

Property 2 of a SIRS N is because the underlying Poisson line process is invariant by translation and rotation. As for change of scale, the underlying Poisson line process is invariant by a transformation where scale is multiplied by α and speed by $\alpha^{(d-1)/(\gamma-1)}$. Hence, all paths have their time length multiplied by the same $\alpha^{(\gamma-d)/(\gamma-1)}$, so that the geodesics are the same and \mathcal{N} is invariant.

Property 3 of a SIRS N is Theorem 5.1.

Property 4 of a SIRS N is Theorem 6.1. \square

7. Conclusion. We have established that the improper Poisson line process with adequate speed limits yield a SIRS N .

Along the way, a few questions have been raised. Is there an easier, more natural way to prove uniqueness of geodesics? What are the tightest moments of the Euclidean length of a geodesic? When can we generalize this construction using geodesics from a random geodesic metric space?

On a more general note, we may wonder which property of our network \mathcal{N} translate to general SIRS N s, or to SIRS N s made of geodesics of a metric space. For example, it should be easy to show that not all SIRS N s have the equivalent of Lemma 4.6 or Corollary 4.9: it is certainly not true for the binary hierarchy model by Aldous.

We might also raise a few typical questions in stochastic geometry. Is there only one geodesic connecting a prescribed point x to infinity, like in dimension two? In many models, infinite geodesics have an asymptotic direction.

For SIRSs, this property looks unlikely, and characterizing the random walk of the angle as a function of the Π -distance to x looks worthwhile. What is the law of a typical cell in the tessellation generated by the network connecting the points of Ξ_1 , an intensity 1 Poisson point process?

Finally, another somewhat tangential direction of research would be to study more closely the properties of the random metric space. For example, being a SIRS entails coalescence of geodesics, a very hyperbolic-like property. We may also draw comparisons with a well-known random metric space such as the Brownian map [see, e.g., Le Gall (2014)].

The Brownian map is a random metric space homeomorphic to the sphere \mathbb{S}^2 . It has Hausdorff dimension 4. All its geodesics minus their endpoints is of Hausdorff dimension 1. The cut-locus of its geodesics starting from a given point has Hausdorff dimension 2, and the topology of an open continuous tree.

On the other hand, we have shown that our metric space is homeomorphic to \mathbb{R}^d . It should be easy, by scaling arguments, to show that its Hausdorff dimension is $(d\gamma - d)/(\gamma - d)$, which is bigger than d . In particular, with $d = 2$ and $\gamma = 3$, we have the same dimensions as the Brownian map. If any geodesic can be appropriately approximated by geodesics between points of Poisson point processes, it should also be easy to show that the geodesics minus their endpoints is of dimension 1. However, the cut-locus might have a very different behaviour.

Acknowledgements. I would like to thank Wilfrid Kendall for introducing us to the problem during a talk, and helpful discussions since then. Remarks from a referee have greatly improved the presentation of the paper.

REFERENCES

- ALDOUS, D. (2014). Scale-invariant random spatial networks. *Electron. J. Probab.* **19** no. 15, 41. [MR3164768](#)
- ALDOUS, D. and GANESAN, K. (2013). True scale-invariant random spatial networks. *Proc. Natl. Acad. Sci. USA* **110** 8782–8785. [MR3082274](#)
- ALDOUS, D. J. and KENDALL, W. S. (2008). Short-length routes in low-cost networks via Poisson line patterns. *Adv. in Appl. Probab.* **40** 1–21. [MR2411811](#)
- KALAPALA, V., SANWALANI, V., CLAUSET, A. and MOORE, C. (2006). Scale invariance in road networks. *Phys. Rev. E (3)* **73** 026130.
- KENDALL, W. S. (2015). From random lines to metric spaces. *Ann. Probab.* To appear.
- LE GALL, J. F. (2014). Random geometry on the sphere. Preprint. Available at [arXiv:1403.7943](#).
- MØLLER, J. and WAAGEPETERSEN, R. P. (2003). *Statistical Inference and Simulation for Spatial Point Processes*. Chapman & Hall, Boca Raton.
- SLIVNYAK, I. M. (1962). Some properties of stationary flows of homogeneous random events. *Theory Probab. Appl.* **7** 336–341.

STOYAN, D., KENDALL, W. S. and MECKE, J. (1996). *Stochastic Geometry and Its Applications*. Wiley, New York.

LABORATOIRE PAUL PAINLEVÉ (UMR 8524)
UNIVERSITÉ DE LILLE 1, CNRS
CITÉ SCIENTIFIQUE—BÂT. M2
59655 VILLENEUVE D'ASCQ CEDEX
FRANCE
E-MAIL: jonas.kahn@math.univ-lille1.fr