



**HAL**  
open science

# Predictive Control and Optimal Design of Thermal Storage Systems for Multi-energy District Boilers

Mouchira Labidi, Julien Eynard, Olivier Faugoux, Stéphane Grieu

► **To cite this version:**

Mouchira Labidi, Julien Eynard, Olivier Faugoux, Stéphane Grieu. Predictive Control and Optimal Design of Thermal Storage Systems for Multi-energy District Boilers. 19th International Federation of Automatic Control World Congress, Aug 2014, Le Cap, South Africa. pp.10305-10310, 10.3182/20140824-6-ZA-1003.01589 . hal-01118452

**HAL Id: hal-01118452**

**<https://hal.science/hal-01118452>**

Submitted on 19 Feb 2015

**HAL** is a multi-disciplinary open access archive for the deposit and dissemination of scientific research documents, whether they are published or not. The documents may come from teaching and research institutions in France or abroad, or from public or private research centers.

L'archive ouverte pluridisciplinaire **HAL**, est destinée au dépôt et à la diffusion de documents scientifiques de niveau recherche, publiés ou non, émanant des établissements d'enseignement et de recherche français ou étrangers, des laboratoires publics ou privés.

# Predictive Control and Optimal Design of Thermal Storage Systems for Multi-energy District Boilers

Mouchira Labidi <sup>\*,\*\*</sup> Julien Eynard <sup>\*\*,\*\*\*</sup>  
Olivier Faugeron <sup>\*\*,\*\*\*</sup> Stéphane Grieu <sup>\*\*,\*\*\*</sup>

<sup>\*</sup> *Cylergie, 18 Avenue Tony Garnier, 69007 Lyon, France*

<sup>\*\*</sup> *PROMES-CNRS, Rambla de la Thermodynamique, Tecnosud, 66100 Perpignan, France*

<sup>\*\*\*</sup> *University of Perpignan Via Domitia, 52 Avenue Paul Alduy, 66860 Perpignan, France*

*mouchira.labidi@promes.cnrs.fr, julien.eynard@promes.cnrs.fr,  
olivier.faugeron@promes.cnrs.fr, stephane.grieu@promes.cnrs.fr*

---

**Abstract:** As part of the second phase of the OptiEnR research project, the present work deals with improving the operation of a multi-energy district boiler by adding to the plant an optimally designed and controlled thermal storage tank. Previous study focused on both a design approach, based on a parametric analysis, and a non-predictive control strategy. The aim of the present work was to develop a Model Predictive Controller (MPC) to improve the management of the tank in real time. The proposed controller generates optimal command sequences dealing with the amount of thermal energy to be stored or released. As a result, both the fossil energy consumption and CO<sub>2</sub> emissions are significantly reduced while the economic gain is increased.

*Keywords:* Multi-energy district boiler, thermal storage tank, optimal design, model predictive control, management strategy.

---

## 1. INTRODUCTION

According to the International Energy Agency (2013), 31.6 billion tons of carbon dioxide were emitted worldwide last year, what represents an increase of 1.4%. As a result, the organisation has made three main recommendations: (i) efforts should be focused on improving energy efficiency in buildings, transport and industry, (ii) fossil fuels must be replaced by low-emission sources of energy, (iii) the release of methane has to be reduced (unburned natural gas with high greenhouse effect) in oil and gas industries.

Because of the global energy crisis, the French government supports renewable energy production. As buildings account for about 40% of total final energy consumption (more than half of this consumption is used for heating), France makes a specific effort in this sector. In addition, using biomass materials such as wood in industrial and residential heating can significantly reduce the reliance on fossil fuels and limit CO<sub>2</sub> emissions (Kitzing et al., 2012). In financial terms, biomass is cheaper than many fossil fuels commonly used for heating. As a key point, advanced control techniques and management strategies are needed to improve the operation of multi-energy district boilers. In this sense, the OptiEnR research project focuses on optimizing the performance of the plants operated by Cofely GDF-Suez, our industrial partner, by adding thermal storage systems.

Thermal energy storage is an attractive technology used in several industrial plants such as Combined Heat and Power

(CHP) plants (Taljan et al., 2012), Central Solar Heating (CSH) plants (Rodríguez-Hidalgo et al., 2012) or multi-energy district boilers (Eynard et al., 2011a, 2012). It has been highlighted in a previous work (Labidi et al., 2013) that once optimally designed and managed (we proposed a non-predictive strategy), a storage tank can improve in a significant way the overall efficiency of a plant.

So, the present paper deals with the optimal management of a thermal storage tank using a Model Predictive Controller (MPC). We focused on the analysis of the energy savings one can achieve thanks to such an advanced control approach. First, the multi-energy district boiler we selected is described (section 2). Next, the reliable (non-predictive) management strategy which was presented in the above-mentioned work is presented. The advantages and limitations are outlined (section 3). They account for the use of a predictive strategy. Then, the design of the MPC controller allowing the thermal storage tank to be efficiently managed is carried out (section 4). Lastly, a comparison between both strategies is performed (section 5). As a result, it can be highlighted that the way the tank is controlled is a key factor. Indeed, the efficiency of such a system is mainly related to its design and the way it is managed. The paper ends with a conclusion and an outlook to future work (section 6).

## 2. MULTI-ENERGY DISTRICT BOILER

We selected as a case study a multi-energy district boiler managed by Cofely GDF-Suez and located in the northeast

of France, in the Alsace region (Haut-Rhin). Alsace has a semi-continental climate with cold and dry winters and hot summers. In addition, there is little precipitation. The plant is connected to a heat network for thermal energy distribution (Fig. 1).

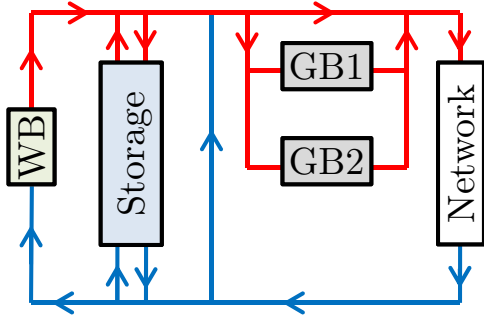

Fig. 1. Synoptic of the multi-energy district boiler.

The biomass (wood) boiler (WB) is characterized by a minimum ( $P_{WB}^{min}$ ) and a maximum heat power ( $P_{WB}^{max}$ ) as well as a variable efficiency ( $\eta$ ). Efficiency, for each operation point, can be defined using interpolation. Usually,  $P_{WB}^{min}$  is higher or equal to 25% of  $P_{WB}^{max}$ . The biomass boiler is designed in order to meet the major part of the power demand but is not able to cover the peak loads. As a result, a 7000 kW gas boiler (GB1) is used as a backup unit. In addition, a 9000 kW gas boiler (GB2) is switched on in case of malfunction or during maintenance phases. Unlike biomass boilers, efficiency is the same whatever the power.  $P_{GB}^{min}$  is about 2% of  $P_{GB}^{max}$ . Table 1 summarizes the characteristics of the boiler units:

Table 1. Characteristics of the boiler units.

Boiler unit	$P$ [kW]	$\eta$
WB	1050	0.7
	2100	0.75
	3150	0.88
	4200	0.95
GB1	140	0.97
	7000	0.97
GB2	180	0.97
	9000	0.97

### 3. NON-PREDICTIVE STRATEGY (NPS)

#### 3.1 Overview of the strategy

Usually, the biomass power is modulated between  $P_{WB}^{min}$  and  $P_{WB}^{max}$  to meet the demand. When it is lower than  $P_{WB}^{min}$ , the biomass boiler is switched off and the backup boiler (GB1) is used. During the coldest periods of winter, both boilers (WB and GB1) operates jointly. In this case, WB operates at full load.

The main purpose of the previous study we carried out (Labidi et al., 2013) was to optimize the operation of multi-energy district boilers by adding optimally-sized thermal storage tanks and proposing an adequate (sequential) management strategy. As a key point, the main goal of thermal energy storage is to avoid switching on the gas boiler (GB1) as far as possible. Such a process leads to

significant changes in fossil and renewable energy consumption. So, a multi-energy district boiler equipped with a thermal storage tank can be operated using the strategy described as follows, on the basis of an estimate of the power demand ( $P_{net}$ ) and the characteristics of the boiler units:

- During the coldest months of winter ( $P_{net} < P_{WB}^{max}$ ), instead of modulating its power, the biomass boiler operates at full load to meet the power demand and charge the thermal storage tank. Once such a demand is upper than  $P_{WB}^{max}$ , the stored energy is released. In this way, the gas boiler is only switched on when the tank is empty and the power demand still exceeds  $P_{WB}^{max}$ .
- During the hottest months of summer ( $P_{net} < P_{WB}^{min}$ ), most of the buildings do not need to be heated and, as a consequence, only domestic hot water is required. Generally, biomass boilers are oversized in order to be able to operate during this period of the year and a gas boiler is used to meet low power requirements. A biomass boiler combined with a thermal storage tank can be used during such a period as follows: first the biomass boiler operates at minimum power and allows both the power demand to be met and the tank to be charged. Once the storage tank is completely filled, the boiler is shut down and the stored energy is released to afford domestic hot water. The boiler is switched on again when the tank is empty. This operating mode prevents the use of gas and favours the use of renewable energy.

#### 3.2 Advantages and limitations

The main advantages of such a strategy are listed below. First, it is based on logical conditions and, as a result, no complex algorithm involving extensive calculation is needed. Secondly, it allows the specificities of each plant (through profiles of power demand and technical characteristics) to be taken into account. As a result, this strategy can be applied to any (existing or under-construction) multi-energy district boiler.

The main drawback of the strategy lies in not taking into account the future power demand. Consequently, the thermal storage tank cannot be used in an optimal way and, in some cases, it is unable to cope with peak loads. In addition, it can be sometimes full and not used for a long time. In this case, thermal losses occur. That is why a predictive strategy based on a MPC controller is likely to improve operation and performance.

### 4. MODEL PREDICTIVE CONTROL (MPC)

#### 4.1 Principles of MPC

It is somewhat curious to note that the concept of Model-based Predictive Controller (MPC) has a long history that began during the 1970's when Engineers at Shell Oil developed their own dependent MPC technology with an initial application in 1973 (García et al., 1989). Nowadays, this concept is widely used in the control of industrial processes. Its popularity in industry is mainly due to the possibility it offers to treat operating specifications and

constraints jointly during the development phase of the controller. MPC is commonly used to manage thermal comfort (Castilla et al., 2013; Pravara et al., 2011) and energy resources (Ma et al., 2012; Kim, 2013) in buildings. Eynard et al. (2012) developed a predictive controller in order to optimize the operation of a multi-energy district boiler located in northwest France.

As it is well known, the philosophy of MPC is down to use a model to forecast the behavior of the system to be controlled and choose the best decision in the sense of some objective function ( $J$ ) while satisfying the constraints. Usually, the aim is to ensure the desired set-point regardless of disturbances with minimal effort. Constraints deal with physical limitations and are introduced for economic or security reasons. The forecast horizon is the time interval during which the objective function is minimized thanks to an optimization algorithm (Manenti, 2011).

#### 4.2 Design of the model predictive controller

In this section of the paper, the MPC problem is formulated. The aim is to optimize the control input that minimizes the consumption of energy (or operational costs) while meeting power demand requirements. The proposed model predictive controller defines the amount of energy to be stored or released through the storage tank at each time step. The architecture of the predictive control approach we propose to manage the amount of thermal energy stored in the tank is depicted by Fig. 2:

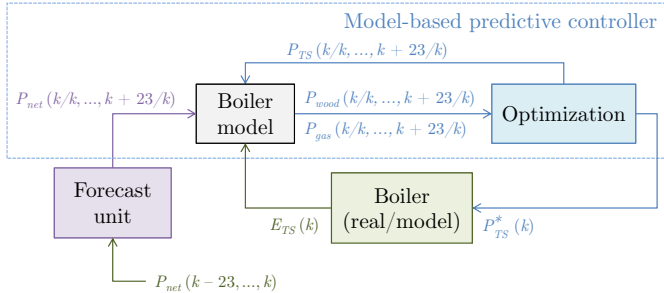

Fig. 2. Structure of the model-based predictive controller.

*Model of the multi-energy district boiler.* The MPC controller we designed uses the global model of the multi-energy district boiler described in section 2 (Labidi et al., 2013). The gas power ( $P_{gas}$ ) as well as the wood power ( $P_{wood}$ ) (i.e. the model outputs) are defined as functions of both the tank charging/discharging power ( $P_{TS}$ ) and the power demand ( $P_{net}$ ) (i.e. the model inputs).  $P_{net}$  is forecasted using a wavelet-based multi-resolution analysis and feedforward artificial neural networks (Eynard et al., 2011b). The main idea behind such an approach is to replace the forecasting of an original time series whose variability can be high by the forecasting of its wavelet coefficients (of lower variability). We decided for a forecast horizon ( $H_f$ ) of 24 hours, as an interesting compromise between forecasting accuracy and periodicity in power demand. In addition, such an horizon is well adapted to the charging and discharging cycles of the tank.

*Optimization variables.* The proposed controller defines at each time step  $k$  the optimal values of the tank charging/discharging power ( $P_{TS}$ ), along the forecast horizon.

Let us note that a positive value (i.e.  $P_{TS}(k) > 0$ ) stands for the “charging (storage) mode” while a negative value (i.e.  $P_{TS}(k) < 0$ ) is for the “discharging (release) mode”.

*Objective function.* The main goal of the control approach is to minimize the use of fossil energy by optimizing the storage of renewable energy during low-demand periods and releasing the energy stored when the power demand is high. Thus, the objective function  $J$  is defined as the quadratic sum of the gas power consumed at each time step  $k$  along the forecast horizon.  $J$  is depicted by equation 1:

$$J = \sum_{k=1}^{H_f} P_{gas}(k)^2 \quad (1)$$

*Constraints.* Equations 2 and 3 allow the optimization constraints to be formulated. Such constraints ensure that thermal energy is stored or released adequately. The first one (2) is introduced in order to limit the interval of the possible values for  $P_{TS}$ . This constraint is related to the characteristics of the storage tank feed pumps. The second constraint (3) makes reference to the design of the tank. In other words, it is related to the capacity of the tank ( $E_{max}$ ).  $E_{max} = \rho \cdot C_p \cdot V \cdot \Delta T$  with  $\rho$  (kg/m<sup>3</sup>) the water density,  $C_p$  (kJ/kg·K) the specific heat of water,  $\Delta T$  (K) the difference in temperature between cold and hot water and  $V$  the volume of the tank (m<sup>3</sup>). At each time step  $k$ , the amount of energy stored has to be positive and lower than  $E_{max}$ :

$$-P_{TS}^{max} \leq P_{TS}(k+j/k) \leq P_{TS}^{max} \quad \forall j \in \llbracket 0; H_f - 1 \rrbracket \quad (2)$$

$$0 \leq E_{init} + \sum_{i=0}^j P_{TS}(k+i/k) \leq E_{max} \quad \forall j \in \llbracket 0; H_f - 1 \rrbracket \quad (3)$$

*Optimization problem.* The optimization problem comes down to find, at each time step  $k$  ( $t = k \times Ts$  with  $Ts$  the sampling time), the value of the manipulated variable  $P_{TS}$  such that the function  $J$  is minimized and the constraints are satisfied (4 and 5):

$$\min (J) \quad (4)$$

$$[P_{TS}(k/k), \dots, P_{TS}(k+H_f-1/k)]$$

$$\begin{cases} \text{District boiler model with thermal storage tank} \\ -P_{TS}^{max} \leq P_{TS}(k+j/k) \leq P_{TS}^{max} \\ 0 \leq E_{init} + \sum_{i=0}^j P_{TS}(k+i/k) \leq E_{max} \\ \forall j \in \llbracket 0; H_f - 1 \rrbracket \text{ and } H_f = 24 \end{cases} \quad (5)$$

*MPC algorithm.* Fig. 3 depicts the MPC algorithm used. At each time step  $k$ , a simulation over the forecast horizon based on the non-predictive strategy, the current amount of energy stored in the tank and the forecasted values of  $P_{net}$  is performed in order for the values of  $[P_{TS}(k/k), \dots, P_{TS}(k+H_f-1/k)]$  to be initialized. These values are then optimized using both the non-linear optimization algorithm “fmincon” from Matlab<sup>®</sup> and the developed model of the multi-energy district-boiler. The first optimized value is applied to the model which stands for the real system and so on until the end of the simulation process. Then, various performance criteria are computed for an off-line analysis of the results.

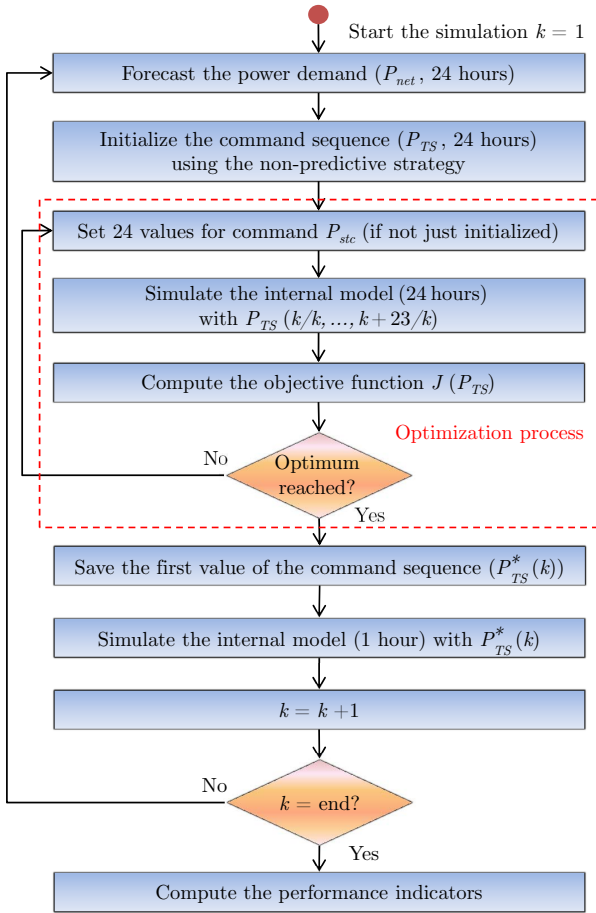

Fig. 3. MPC algorithm.

## 5. RESULTS

This section of the paper deals with the control results we obtained. Three different scenarios are considered in order to check performance:

- Scenario 1: District boiler without thermal storage tank. This is the “Reference Scenario” (RS).
- Scenario 2: District boiler with thermal storage tank managed with the “Non-Predictive Strategy” (NPS) discussed in section 3 of the paper.
- Scenario 3: District boiler with thermal storage tank managed with the MPC strategy discussed in section 4 of the paper.

Energy, economic and environmental criteria are proposed as performance indicators. Thanks to these indicators and considering a thermal storage tank whose size can vary from  $0\text{ m}^3$  to  $1000\text{ m}^3$ , one can evaluate the performance of the proposed strategies (predictive and non-predictive) as well as the impact of the volume of the tank on the multi-energy district boiler operation.

### 5.1 Performance indicators and simulation parameters

Because the main purpose of thermal energy storage is to decrease gas consumption in multi-energy district boilers, the gas coverage rate ( $C_{gas}$ ) is proposed as an energy indicator. It is calculated from the thermal energy produced from the combustion of gas ( $E_{gas}$ ) and wood ( $E_{wood}$ ) during the considered period (6).

$$C_{gas} = \frac{E_{gas}}{E_{wood} + E_{gas}} \quad (6)$$

The wood coverage rate ( $C_{wood}$ ) is computed in the same way than  $C_{gas}$  and is subject to contract (7):

$$C_{wood} = \frac{E_{wood}}{E_{wood} + E_{gas}} \quad (7)$$

With the aim of highlighting the economic benefits of energy savings, a criterion ( $Ec$ ) is defined from  $E_{gas}$ ,  $E_{wood}$ ,  $UP_{gas}$  (the unitary price of gas), and  $UP_{wood}$  (the unitary price of wood) (8):

$$Ec = E_{gas} \times UP_{gas} + E_{wood} \times UP_{wood} \quad (8)$$

In order to put in perspective the economic benefits of energy savings, the economic gain  $G$  is evaluated (9). It is defined as the difference between  $Ec(V)$ , the economic cost related to energy consumption, considering a storage volume  $V$ , and  $Ec(V=0)$ , the economic cost related to energy consumption without storage of thermal energy ( $V=0\text{ m}^3$ ):

$$G(V) = Ec(V) - Ec(V=0) \quad (9)$$

The environmental impact of such a technology is evaluated thanks to criterion  $L_{CO_2}$ , which is about  $\text{CO}_2$  emissions (10).  $L_{CO_2}$  is expressed from  $Ec_{gas}$ ,  $Ec_{wood}$  and the Life-Cycle Assessment of  $\text{CO}_2$  emissions from gas ( $U_{CO_2}^{gas}$ ) and wood ( $U_{CO_2}^{wood}$ ):

$$L_{CO_2} = Ec_{gas} \times U_{CO_2}^{gas} + Ec_{wood} \times U_{CO_2}^{wood} \quad (10)$$

It should also be noted that new buildings connected to the heat network as well as future expansions of existing buildings are factors to be taken into account in order to evaluate the proposed strategy accurately. As a result, we considered an increase in the power demand ( $P_{net}$ ) up to 30% and studied the impact of such an increase on the plant operation. Finally, table 2 summarizes the main simulation parameters.

Table 2. Simulation parameters.

Parameter	Value
Simulation period	From September 21 to April 16
Sampling time ( $T_s$ )	1 hour
Forecast horizon ( $H_f$ )	24 hours
$P_{TS}^{max}$	$\frac{E_{max}}{2}$ [kW]
$UP_{gas}$	40 €·MWh <sup>-1</sup>
$UP_{wood}$	17 €·MWh <sup>-1</sup>
$U_{CO_2}^{gas}$	234 kgCO <sub>2</sub> ·MWh <sup>-1</sup>
$U_{CO_2}^{wood}$	13 kgCO <sub>2</sub> ·MWh <sup>-1</sup>

### 5.2 Simulation results

First, simulation results show that the biomass boiler is sized to ensure around 85% of the power demand during the simulation period without thermal storage tank ( $V=0\text{ m}^3$ ). Fig. 5 depicts the way the gas coverage rate evolves according to the volume of the storage tank and the strategy used (NPS or MPC). Let us remember that NPS is for “Non-Predictive Strategy” while RS stands for

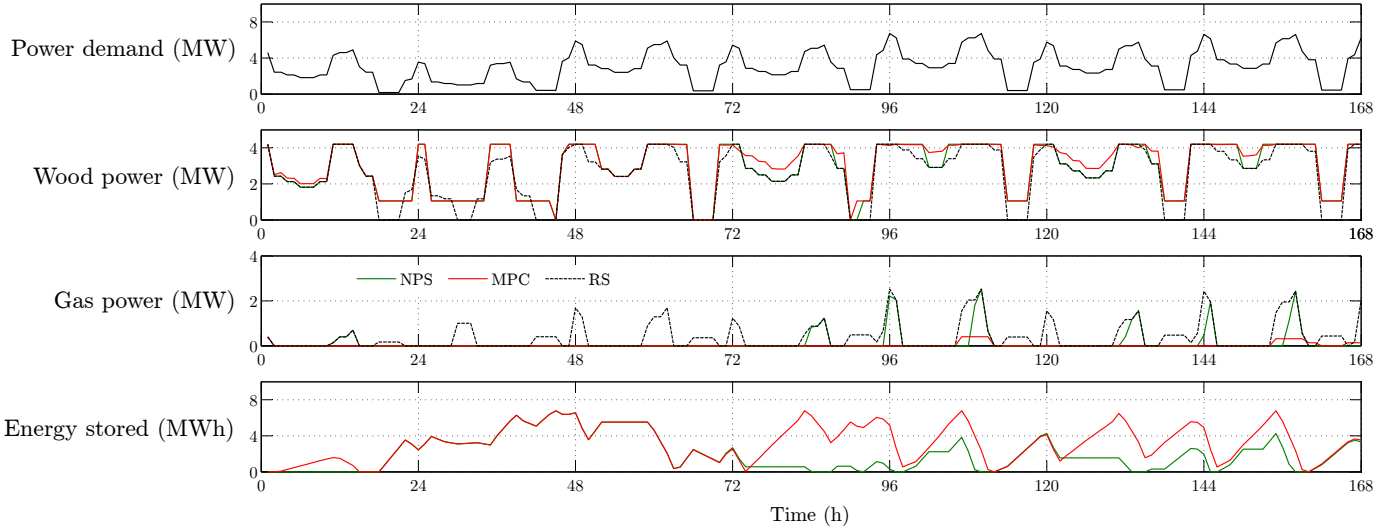

Fig. 4. Weekly dynamics of the multi-energy district boiler.

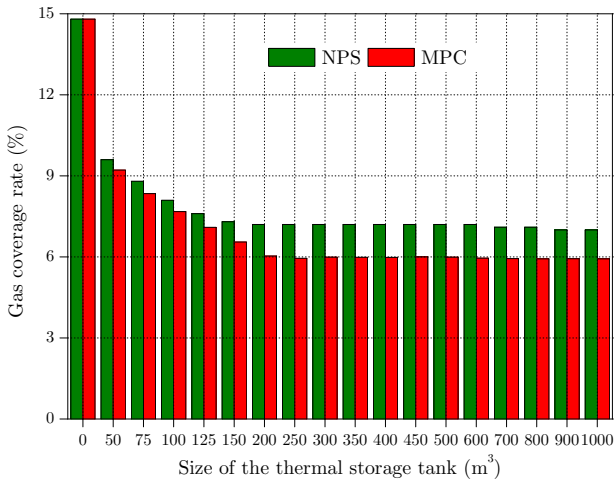

Fig. 5. Impact of the size of the tank on  $C_{gas}$ .

“Reference Scenario”. One can highlight that, regardless of the strategy used, adding to a plant a thermal storage tank reduces the use of the gas boiler significantly. Moreover, whatever the size of the tank, the predictive strategy is always more efficient. For example, when adding to the plant a  $200\text{m}^3$  thermal storage tank managed using the non-predictive strategy, the gas coverage rate decreases down to 7.3%. The same tank managed using the predictive strategy allows this rate to be decreased until 6%.

Fig. 4 presents the dynamics of the district boiler during one week. Taking a look at the figure, it can be highlighted that the predictive controller anticipates very well the storage of thermal energy even if the current power demand is very low, knowing 24 hours in advance that such a demand will increase sharply. Figures 6 and 7 depict, for both strategies, the way the size of the tank impacts on  $Ec$  and  $G$ , respectively. One can highlight that  $Ec$  decreases with the size of the thermal storage tank. Furthermore, in comparison to the non-predictive strategy, the MPC strategy allows a considerable economic gain to be realized.

With the non-predictive strategy, the optimal volume of the tank is about  $200\text{m}^3$ . A more important volume

is not reflected by a bigger economic gain. With the MPC strategy, the optimum is reached for a volume of about  $300\text{m}^3$ . This highlights that such a strategy takes advantage of an increase in the size of the tank and demonstrates its ability in managing energy resources. From an environmental point of view, Fig. 8 clearly shows for the same thermal storage tank that the MPC strategy allows a higher decrease in  $\text{CO}_2$  emissions than the non-predictive strategy.

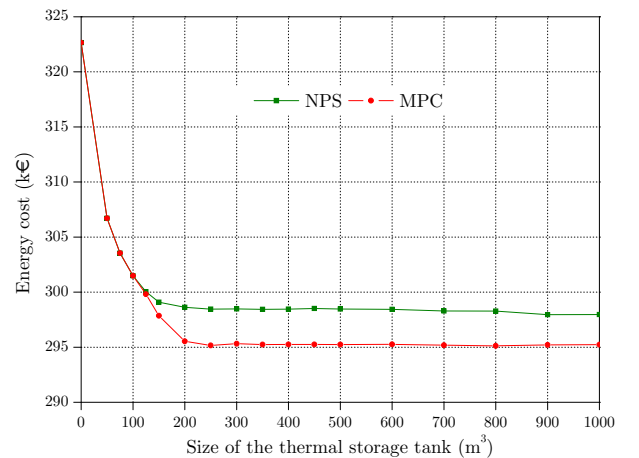

Fig. 6. Impact of the size of the tank on  $Ec$ .

A possible increase in power demand is also considered in order to complete the analysis. Regarding the ability of the thermal storage tank to cope with such an increase, one can observe (Fig. 9) that the predictive strategy allows the wood coverage rate to be about 2 points higher than with the non-predictive strategy, for a volume of  $200\text{m}^3$ , and from 4 to 10 points higher than with the reference scenario (i.e. no thermal storage tank).

## 6. CONCLUSION

The present paper deals with optimizing the operation of a multi-energy district boiler by adding to the plant an optimally-sized thermal storage tank. First, we proposed a non-predictive strategy in order to manage the plant,



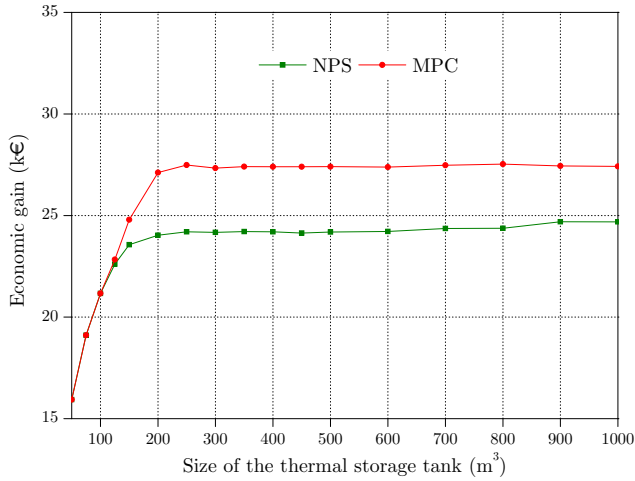

Fig. 7. Impact of the size of the tank on  $G$ .

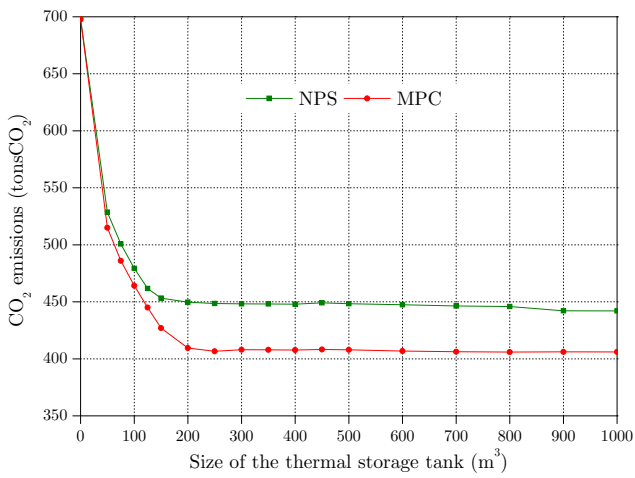

Fig. 8. Impact of the size of the tank on  $LCO_2$ .

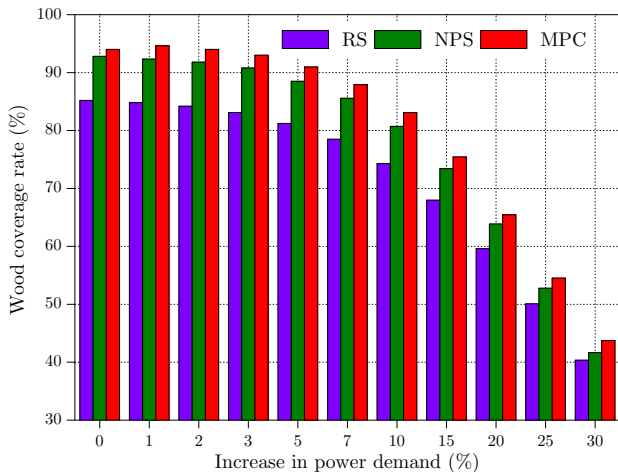

Fig. 9. Impact of an increase in power demand on  $C_{wood}$ .

on the basis of the power demand and the characteristics of the different boiler units. Next, a model predictive controller has been developed in order to optimize, over a forecast horizon, the use of the storage tank. As a key point, one can highlight that the control scheme allows both the fossil energy consumption and CO<sub>2</sub> emissions to be significantly reduced. In addition, the economic gain is

increased. Ongoing research activities will now focus on improving the tool used to forecast the power demand. Other multi-energy district boilers and configurations will also be considered in order to validate the predictive approach. Future work will also deal with implementing in situ the developed algorithm.

## REFERENCES

- Castilla, M.D., Alvarez-Hervás, J.D., Normey-Rico, J.E., and Rodríguez-Díaz, F. (2013). Thermal comfort control using a non-linear mpc strategy: A real case of study in a bioclimatic building. *Journal of Process Control*, in press.
- Eynard, J., Grieu, S., and Polit, M. (2011a). Optimal Control of a Multi-Energy District Boiler: A Case Study. In *Proceedings of the 18th International World Congress of the International Federation of Automatic Control*, 8271–8276.
- Eynard, J., Grieu, S., and Polit, M. (2011b). Wavelet-based multi-resolution analysis and artificial neural networks for forecasting temperature and thermal power consumption. *Engineering Applications of Artificial Intelligence*, 24(3), 501–516.
- Eynard, J., Grieu, S., and Polit, M. (2012). Predictive control and thermal energy storage for optimizing a multi-energy district boiler. *Journal of Process Control*, 22(7), 1246–1255.
- García, C.E., Prett, D.M., and Morari, M. (1989). Model predictive control: Theory and practice – a survey. *Automatica*, 25(3), 335–348.
- International Energy Agency (2013). Key world energy statistics 2013. OECD/IEA.
- Kim, S.H. (2013). Building demand-side control using thermal energy storage under uncertainty: An adaptive multiple model-based predictive control (mmpc) approach. *Building and Environment*, 67, 111–128.
- Kitzing, L., Mitchell, C., and Morthorst, P.E. (2012). Renewable energy policies in Europe: Converging or diverging? *Energy Policy*, 51, 192–201.
- Labidi, M., Eynard, J., Faugeroux, O., and Grieu, S. (2013). Optimal design of thermal storage tanks for multi-energy district boilers. In *Proceedings of the 4th Inverse Problems, Design and Optimization Symposium*.
- Ma, J., Qin, J., Salsbury, T., and Xu, P. (2012). Demand reduction in building energy systems based on economic model predictive control. *Chemical Engineering Science, Dynamics, Control and Optimization of Energy Systems*, 67(1), 92–100.
- Manenti, F. (2011). Considerations on nonlinear model predictive control techniques. *Computers and Chemical Engineering*, 35(11), 2491–2509.
- Pravara, S., Va, Z., Cigler, J., Oldewurtel, F., and Komrek, J. (2011). Role of MPC in building climate control. *Computer Aided Chemical Engineering*, 29, 728–732.
- Rodríguez-Hidalgo, M.D., Rodríguez-Aumente, P.A., Lecuona, A., Legrand, M., and Ventas, R. (2012). Domestic hot water consumption vs. solar thermal energy storage: The optimum size of the storage tank. *Applied Energy*, 97, 897–906.
- Taljan, G., Verbic, G., Pantos, M., Sakulin, M., and Fickert, L. (2012). Optimal sizing of biomass-fired Organic Rankine Cycle CHP system with heat storage. *Renewable Energy*, 41, 29–38.