



HAL
open science

Simulation of a Photovoltaic Conversion System using Energetic Macroscopic Representation

Walter Lhomme, Philippe Delarue, Frédéric Giraud, Betty Lemaire-Semail, Alain Bouscayrol

► **To cite this version:**

Walter Lhomme, Philippe Delarue, Frédéric Giraud, Betty Lemaire-Semail, Alain Bouscayrol. Simulation of a Photovoltaic Conversion System using Energetic Macroscopic Representation. Power Electronics and Motion Control Conference (EPE/PEMC), 2012 15th International, Sep 2006, Novi Sad, Serbia. 10.1109/EPEPEMC.2012.6397361 . hal-01111851

HAL Id: hal-01111851

<https://hal.science/hal-01111851>

Submitted on 31 Jan 2015

HAL is a multi-disciplinary open access archive for the deposit and dissemination of scientific research documents, whether they are published or not. The documents may come from teaching and research institutions in France or abroad, or from public or private research centers.

L'archive ouverte pluridisciplinaire **HAL**, est destinée au dépôt et à la diffusion de documents scientifiques de niveau recherche, publiés ou non, émanant des établissements d'enseignement et de recherche français ou étrangers, des laboratoires publics ou privés.

Simulation of a PhotoVoltaic Conversion System using Energetic Macroscopic Representation

W. Lhomme P. Delarue, F. Giraud, B. Lemaire-Semail, A. Bouscayrol,
L2EP, Université Lille1, France

Topic 14 (Education) - Preference: dialog presentation

Abstract — *The Energetic Macroscopic Representation (EMR) has been developed in 2000 to develop control of electric systems. Since 2002 this graphical tool has been introduced to teach control of electrical systems in France, then Canada and Switzerland. A Photovoltaic Conversion System is simulated using EMR in order to present an actual and valuable example for students within renewable energy applications..*

Introduction

Nowadays, control of electrical systems is of main interest in electrical engineers teaching [1]-[3]. But it requires skills in various scientific fields such as power electronics, electrical machines, automatic control, mechanics and control electronics.

Several graphical description has been introduced in order to represent in a uniform way multi-physical systems, such as Bond-Graph (BG) [4], Power Oriented Graph (POG), Causal Ordering Graph (COG) [6][7], or Energetic Macroscopic Representation (EMR) [8]. BG and POG are structural descriptions more dedicated to the system design. COG and EMR are functional descriptions more focused on the control design, because of the use of the exclusive integral causality [9][10]. In that case, the control scheme of the system can be directly deduced from an inversion of the model description [11]. These two descriptions have been successfully used for control of various applications [11]-[13].

Because of the system-oriented description for modelling and control, EMR is a valuable methodology to teach control of electrical systems. This formalism is now taught in some French universities [14][15], at University of Québec Trois Rivières (Canada), at Ecole Polytechnique Fédérale de Lausanne (Switzerland), and some recent experiences have been realized at Tsinghua University (China), Aalto University (Finland) and Polytechnical University of Catalunya (Barcelona, Spain) [16]. Indeed such a graphical description enables a unified way for causal description of the components of electromechanical. Moreover, summer schools are regularly organized worldwide (Lille, France, in 2006, Hrabín, China, 2008, Trois-Rivières, Canada, 2009, Lausanne, Switzerland, 2011, Madrid, Spain, 2012) [16].

But, because EMR is a new systemic approach, realistic and simple examples have to illustrate the different concepts. Moreover, practice is required in the manipulation of the different pictograms, their connections and the deduced control, in particular during summer schools when the students have only 3 days of lectures on this topic. Simulation of simple systems have thus been developed in order to illustrate the modelling and the control methods using EMR in very short simulation sessions (typically two sessions of four hours each). First the simulation of an electric vehicle using a DC machine has been developed using EMR library and Matlab-Simulink© [14]. But other systems have to be simulated to demonstrate the flexibility of the method.

In this paper, the simulation of a Photovoltaic (PV) system is studied in order to supply a hydraulic pump. Energy is extracted from the system using a MPPT strategy and is stored in a battery tank. The pump is moved by a DC machine. The EMR of the system is described, and the control scheme is derived from the inversion of this EMR. Finally the entire system is simulated in Matlab Simulink using an EMR library.

I. EMR fundamentals

Interaction principle — The system is decomposed in basic subsystems in interactions (*Table 1*): energy sources (green ovals), accumulation elements (orange rectangles), conversion element without energy accumulation (various pictograms) and coupling elements for energy distribution (orange overlapped pictograms). All the elements are connected according to the action and reaction principle using exchange variable (arrows). The product of action and reaction variables between two elements leads to the instantaneous power exchanged.

Causality principle — As in COG [7], only the integral causality is considered in EMR. This property leads to define accumulation elements by a time-dependant relationship between its variables: its outputs are integral functions of its inputs. Other elements are described using relationships without time dependence. In order to respect the integral causality specific association rules are defined.

Inversion principle — The inversion based control theory has been initiated by COG [7]. The control structure of a system is obtained from an inversion of the system modelling: the control has to define the inputs to apply to the system given the desired output (**Fig. 1**). In this method, relationships which are not time-dependant (i.e. the elements without energy accumulation) are directly inverted (with neither control nor measurement). Because the derivative causality is forbidden, a direct inversion of time-dependant relationships is not possible. An indirect inversion is thus made using a controller and measurements. These inversion rules have been extended to EMR (blue pictograms, see **Table 1**): conversion elements are directly inverted, accumulation elements are inverted using controller and coupling devices are inverted using distribution inputs. It is another way to locate controllers and measurements.

Table 1: Elements of EMR and of control

	Source element (source of energy)		Accumulation element (energy storage)		Indirect inversion (closed-loop control)
	Mono-physical conversion element (no energy storage)		Mono-physical coupling element (energy distribution)		Direct inversion (open-loop control)
	Multi-physical conversion element (no energy storage)		Multi-physical coupling element (energy distribution)		Coupling inversion (energy criteria)

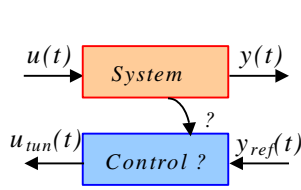

Fig. 1: Inversion-based control principle

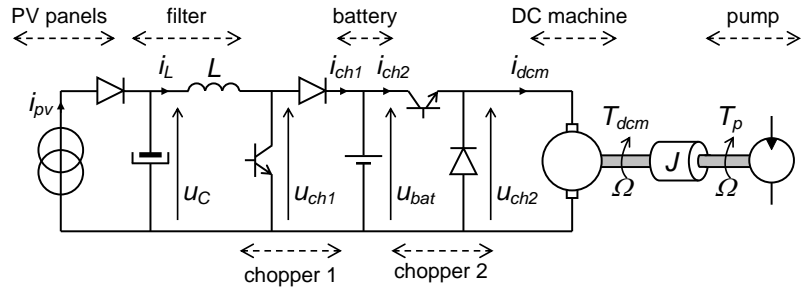

Fig. 2: Studied PV system

II. Modelling and EMR of the studied PV system

Studied PV system — The studied system aims to supply a pump in desert area. It is composed of a PV panel, a LC filter, a boost chopper, a battery, a buck chopper and a DC machine to activate the pump (**Fig. 2**).

Modelling of PV system — The different relationships of each component will be detailed in the final paper. For example, the capacitor voltage of the filter u_C is expressed in function of the PV current i_{PV} and the inductor current i_L :

$$C \frac{d}{dt} u_C = i_{PV} - i_L - \frac{1}{R} u_C \tag{1}$$

where C and R are the capacitance and resistance of the capacitor. As a second example, the boost chopper is described by an average relationship connecting the chopper voltage u_{ch1} to battery voltage u_{bat} , and the chopper current i_{ch1} to the inductor current i_L :

$$\begin{cases} u_{ch1} = m_{ch1} u_{bat} \\ i_{ch1} = m_{ch1} i_L \end{cases} \text{ with } m_{ch1} = 1 - \alpha_{ch1} \tag{2}$$

where α_{ch1} is the duty cycle of the chopper.

EMR of PV system — Each component is translated into EMR elements and their inputs and outputs are defined according to the causality principle. Moreover, connection between elements must respect the interaction principle. For example, the capacitor (1) is an accumulation element, where the voltage u_C is the output in both directions and the currents i_{PV} and i_L are the inputs (see Fig. 3). A crossed orange pictogram is thus used to represent this energy storage. All other EMR elements of the WECS will be described in the final paper. The EMR of the whole system is given in the upper part of Fig. 3.

III. Control of the studied PV system

Inversion-based control of PV system — The control scheme of the PV system is obtained from an inversion of its EMR (see lower part of Fig. 3). The first objective is to extract the maximum of the solar power by acting on chopper 1. The second objective is to impose the right machine velocity to regulate the water flow, by acting on chopper 2. Two control parts are thus organized.

Each relationship is inverted according to inversion rules. For example relationship (2) is directly inverted in order to obtain the modulation ratio reference $m_{ch1-ref}$ from the voltage reference $u_{ch1-ref}$:

$$m_{ch1-ref} = \frac{1}{u_{bat-meas}} u_{ch1-ref} \tag{3}$$

A blue parallelogram is used as pictogram for (3). Because relationship (1) is integral, it can not be directly inverted. A closed-loop control is used for an indirect inversion in order to obtain the current reference i_{L-ref} from the voltage reference u_{C-ref} and the compensation of the PV current:

$$i_{L-ref} = C(t)(u_{C-ref} - u_{C-meas}) + i_{PV-meas} \tag{4}$$

with $C(t)$ the controller, which could be P, PI or other kind. A crossed-blue parallelogram is used as pictogram for (3). The inversion of others elements will be described in the final paper.

MPPT strategy — A ‘‘Perturb & Observ’’ Maximum Power Point Tracking strategy [18] is used to define the reference voltage to impose on the PV panel in order to get the maximal power in function of the irradiance and the temperature (Fig. 4). This strategy will be detailed in the final paper.

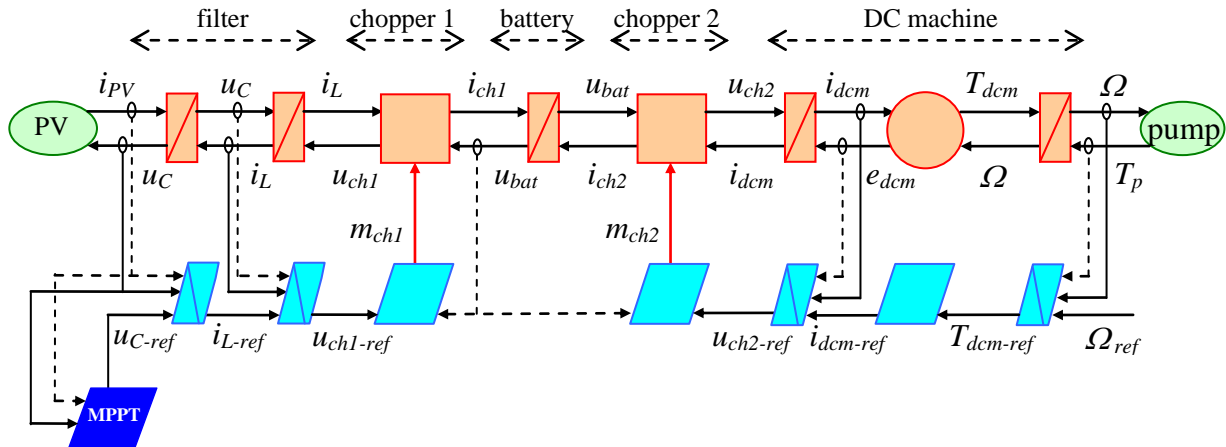

Fig. 3: EMR and deduced control of the studied WECS

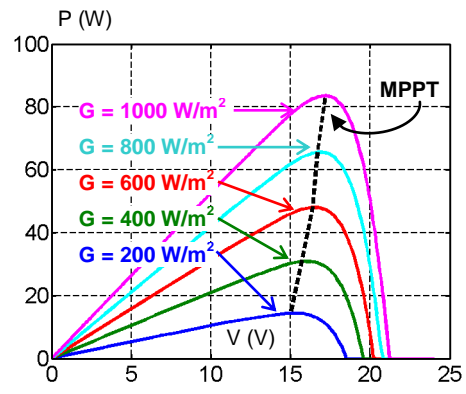

Fig. 4: PV Power versus of the capacitor voltage for different irradiance ($T=25^\circ$)

IV. Simulation of the studied PV System

Simulation requirements — Matlab-Simulink™ is chosen as simulation software. The students have three programs at their disposal: an initialisation program containing the PV system parameters (PV look-up table, filters, battery, and DC machine), a Simulink program with the PV source and the pump, and a Simulink library containing the EMR basic elements.

The objective of the simulation is to study the PV system using a Maximum Power Point Tracking strategy to extract power from the sun, to store this energy when the pump is off, and to use this energy to impose a constant water flow when the pump is on. The students have to build the simulation model of the PV system. They have also to determine all the control structure of both parts, to tune all the controllers and to implement this control in the simulation software. Power electronics is simulated using average values. The MPPT strategy block is provided.

Simulation sessions — Two simulation sessions of four hours each are organized. The first session is focused on the development of the simulation of the system, using the EMR library. The second session is focused on the control part. In order to organise their simulation, the students are invited to describe EMR of the system and the deduced control. Different variables will be plotted in the final paper.

The whole simulink program is achieved by most of the students (Fig. 5). They can study the power extracted from the PV panel under different irradiance (Fig. 6), the battery charge and the rotation speed of the pump. More details will be given in the final paper on that extension.

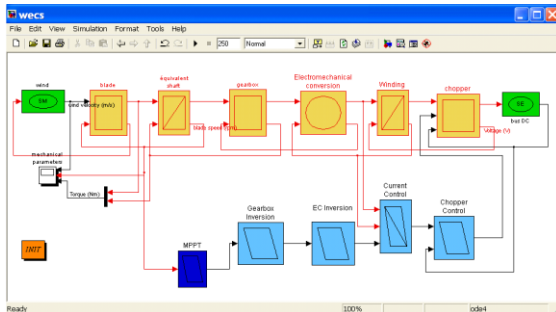

Fig. 5: Matlab-Simulink™ model of the studied PV system and its control

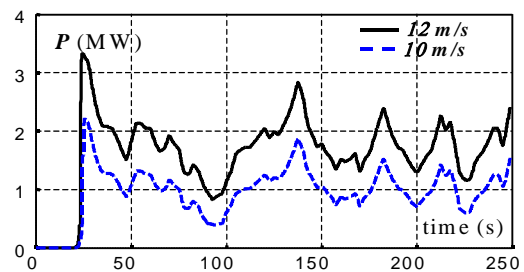

Fig. 6: Extracted power for a variable irradiance

Conclusion

The use of EMR is an efficient methodology to develop student skills on drive control. A unified and physical modelling is developed, and inversion rules are used to find the control scheme. By using this intermediary step, they can easily connect other scientific fields such as power electronics, electrical machines, mechanics and automatic control.

The simulation of a PV System is proposed to acquire the concepts of EMR and of the drive control. First the description of the system is developed in a causal and systemic way. Secondly, the control scheme is deduced and the students can better understand which variable to measure, how many controllers to use, and where they has to be locate. This example is really motivating for the students because it is a renewable energy application.

- [1] F. Blaabjerg, M. Kazmierkowski, J. Pedersen, P. Thorgersen, M. Tonnes, "An industry/university collaboration in power electronics and drives", *IEEE ton Education*, vol. 43, no. 1, February 2000, pp. 52-57.
- [2] P. Buechner, "New facilities for teaching and research with decentralised electric drive systems", *EPE'05*, Dresden (Germany), September 2005.
- [3] P. Gambôa & all, "Modern Technologies for Experimental Education in Industrial Electronics and Electric Drives", *EPE'05*, Dresden, (Germany), September 2005.
- [4] H. Paynter, "Analysis and design of engineering systems", *MIT Press*, 1961.
- [5] R. Zanasi, "Power-Oriented Graphs for Modeling Electrical machines", *MELECOM'96*, Bari (Italy), May 1996, pp. 1211-1214.
- [6] J. P. Hautier, J. Faucher, "Causal Ordering Graph", *Bulletin de l'Union des Physiciens*, (text in French), vol. 90, juin 1996, pp. 167-189.
- [7] J. P. Hautier, P. J. Barre, "The causal ordering graph – A tool for modelling and control law synthesis", *Studies in Informatics and Control Journal*, vol. 13, no. 4, December 2004, pp. 265-283.
- [8] A. Bouscayrol, B. Davat, B. de Fornel, B. François, J. P. Hautier, F. Meibody-Tabar, M. Pietrzak-David, "Multimachine Multiconverter System: application for electromechanical drives", *EPJ Applied Physics*, vol. 10, no. 2, May 2000, pp. 131-147;
- [9] I. Iwasaki, H. A. Simon, "Causality and model abstraction", *Artificial Intelligence*, Elsevier, vol. 67, 1994, pp. 143-194.
- [10] Z. Rubin, S. Munns, J. Moskowa, "The development of vehicular powertrain system modeling methodologies: philosophy and implementation", *System Automotive Engineering*, paper 971089, 1997.
- [11] P. J. Barre, A. Bouscayrol, P. Delarue, E. Dumetz, F. Giraud, J. P. Hautier, X. Kestelyn, B. Lemaire-Semail, E. Semail, "Inversion-based control of electromechanical systems using causal graphical descriptions", *IEEE-IECON'06*, Paris, November 2006.
- [12] Y. Djani, P. Sicard, A. Bouscayrol, "Extension of Energetic Macroscopic Representation to time-varying systems, applications to winder tension control", *IEEE-ISIE'06*, Montreal, July 2006.

- [13] A. Bouscayrol, P. Delarue, X. Guillaud, "Power strategies for Maximum Control Structure of a wind energy conversion system with a synchronous machine", *Renewable Energy*, vol. 30, May 2005, pp. 2273-2288.
- [14] A. Bouscayrol, A. Bruyère, P. Delarue, F. Giraud, B. Lemaire-Semail, Y. Le Menach, W. Lhomme, F. Locment, "Teaching drive control using Energetic Macroscopic Representation - initiation level", *EPE'07*, Aalborg (Denmark), September 2007.
- [15] A. Bouscayrol, P. Delarue, F. Giraud, X. Guillaud, X. Kestelyn, B. Lemaire-Semail, W. Lhomme, "Teaching drive control using Energetic Macroscopic Representation - expert level", *EPE'09*, Barcelona (Spain), September 2009.
- [16] EMR website: <http://emr.univ-lille1.fr/>
- [17] A. Bouscayrol, P. Barrade, L. Boulon, K. Chen, Y Cheng, P. Delarue, F. Giraud, B. Lemaire-Semail, T. Letrouvé, W. Lhomme, P. Sicard, "Teaching drive control using Energetic Macroscopic Representation – Summer schools", *EPE'11*, Birmingham (UK), September 2011.
- [18] N. Femia, G. Petrone, G. Spagnuolo, M. Vitelli, "Optimization of perturb and observe maximum power point tracking method", *IEEE transaction on Power Electronics*, Vol. 20, no. 4, pp. 963 – 973.