



**HAL**  
open science

# ISO Specifications of Complex Surfaces: Application on Aerodynamic Profiles

M Petitcuenot, Laurent Pierre, B Anselmetti

► **To cite this version:**

M Petitcuenot, Laurent Pierre, B Anselmetti. ISO Specifications of Complex Surfaces: Application on Aerodynamic Profiles. CIRP CAP 2014, May 2014, <https://hal.archives-ouvertes.fr>, China. 10.1016/j.procir.2015.04.037 . hal-01094158v1

**HAL Id: hal-01094158**

**<https://hal.science/hal-01094158v1>**

Submitted on 16 Dec 2015 (v1), last revised 19 Dec 2014 (v2)

**HAL** is a multi-disciplinary open access archive for the deposit and dissemination of scientific research documents, whether they are published or not. The documents may come from teaching and research institutions in France or abroad, or from public or private research centers.

L'archive ouverte pluridisciplinaire **HAL**, est destinée au dépôt et à la diffusion de documents scientifiques de niveau recherche, publiés ou non, émanant des établissements d'enseignement et de recherche français ou étrangers, des laboratoires publics ou privés.

12th CIRP Conference on Computer Aided Tolerancing

ISO specifications of complex surfaces:  
Application on aerodynamic profiles

M. Petitcuenot<sup>a,b,\*</sup>, L. Pierre<sup>a,c</sup> and B. Anselmetti<sup>a,c</sup>

<sup>a</sup>LURPA, ENS Cachan, 61, Avenue du président Wilson, 94 235 Cachan, France

<sup>b</sup>Snecma, Site de Villaroche, Rond Point René Ravaud-Réau, 77 550 Moissy-Cramayel, France

<sup>c</sup>Université Paris-Sud, IUT de Cachan, 9, Avenue de la division Leclerc, 94 230 Cachan, France

---

**Abstract**

For many years, the use of complex surfaces is becoming widespread with the development of manufacturing process. CAD model describes nominal shape of the part. Specifications are then defined by annotations directly in the 3D model. This work is illustrated by an application on a turbine blade of an aircraft engine.

To impose the widest possible tolerances on the whole surface, it is necessary to have a multi-scale approach. The main datum reference frame is built on the setting up surfaces of the part.

In the first level, all surfaces are located with regard to the main datum reference frame with a wide tolerance in order to avoid interference with other parts of the mechanism. In a second level, specifications on restricted areas complete local requirements with lower tolerances. In the third level, orientation specification on small mobile zone with small tolerance detects micro defects as tool traces for example.

This presentation shows several positions, orientation and form specifications on 3D surfaces and on 2D curves. The new modifier "For orientation constraint only" of the ISO 5459: 2011 standard lets us define only the orientation with regard to a reference surface. The overlapping of many orientation specifications on restricted areas limits parts defects inside a large global tolerance zone. Specifications with common zone of two surfaces face to face control the thickness of the part which can be useful for strength or mass reasons.

These specifications can be detailed with a variable tolerance zone that defines the tolerance of all points of surfaces. The ISO standard only treats the 2D case; this paper presents a solution to specify 3D surfaces with variable tolerance by a hypothesis of proportional variation following the curvilinear distance on curves created on 3D surfaces.

This set of specifications constitutes a tool-box for designers based on only one type of specification which allows them to verify all requirements with a partition of only one cloud of points.

The 3D complex surfaces are the interface between the part and the outside environment and often require similar functions. This study in a context of aeronautic industry can easily be extended to other mechanical domains.

---

*Keywords:* Functional Tolerancing; Complex surface; Aerodynamic profile; Variable tolerance; ISO standard of tolerancing.

---

## 1. Introduction

### 1.1. Context and studies field

In a classical mechanism, parts need functional geometrical requirements between setting-up surfaces. However, parts on the skin of the mechanism require esthetical or aero-dynamical functions. These surfaces are often complex and have to be defined in a 3D model. The classical method is to impose a specification of profile of the surface with regard to the main datum reference frame, but this approach is not sufficient. A functional multi-scale approach must be used to control various defects.

### 1.2. Industrial needs

In a context of production of aircraft engines, Snecma wants to improve the definition of the aerodynamic profile of their blades.

In a first step, after designating different zones of the blade (Pressure side, Suction side, Leading edge, Trailing edge ...), experts did a functional analysis to determine the geometrical properties of these zones. A typical aerodynamic need is the orientation of a profile which guides the air flow.

It is difficult to determine the influence of a particular default on system performance.

In a second step it is necessary to choose ISO tolerancing specifications to control the form and the location of each zone and the continuity between two neighboring zones.

In a conventional mechanism, datum reference frames are built on planes or cylinders used for positioning adjacent parts. On a blade the next part is an air flow without datum.

### 1.3. State of the art

Specifications of complex surfaces are built only with two symbols of profile of a line and profile of a surface (Fig. 1) defined in the ISO 1101 standard.

Without datum reference frame, the specification controls the form of the surface [1].



Figure 1: Form specifications of a profile of a line and of a surface

With a datum reference frame, specification is a location specification (Fig. 2).

There is no specific symbol for orientation, but the last version of the ISO 5459: 2011 standard [2] gives a new modifier “><”, which removes the position constraint. This means that the tolerance zone can be translated with regard to the nominal surface defined in the datum reference frame (Fig. 2).

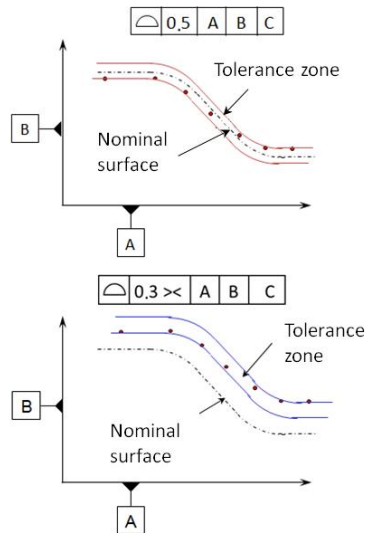

Figure 2: Position and orientation specifications of a complex surface

#### 1.4. Literature review

Functional tolerancing becomes widely used in the industry and multiple researchers have written about this subject.

Mejbri & Al. [3] present a method which builds the best datum reference frame for each functional requirement. After have defined all relevant datum, an algorithm allows us to choose quickly the adapted datum reference frame for each geometrical specification. Tolerancing of part requires two level of analyze. The first one is the set of specifications which only answer to the functional needs of the part, and the second one is the consideration of the assembly by specifying part boundaries. This second approach insures the geometric continuity of surfaces between parts.

In a similar view, Anselmetti B. [4] [5] developed a software application, named “CLIC method”, which can specify a part by an automated way by analyzing contacting features. This method gives a complete datum reference frame corresponding to the functional requirements.

In her thesis Zhang M. [6] uses the concepts of the Skin Model (GeoSpelling [7] [8]) by a discrete shape modeling approach. She performed an analysis on a sheet of metal part manufactured in a one-stage sheet metal forming process.

Some years before Chiabert & Al. [9] show the benefits of the GD&T approach on tolerancing part. The GD&T approach gives a better representation of the reality of the assembly and it allows us to have a better mastery of some defects. Chiabert apply these concepts to a gearbox to demonstrate that GD&T approach permits to put the extra tolerances on the specification that have the greatest impact on the manufacturing cost.

In a context of reduction of manufacturing cost Curran & Al. [10] give a cost model of tolerances of an aircraft engine nacelle. Curran focuses on joints between the large parts which constituted the nacelle.

His cost models give an idea of the influence of the conception, manufacturing and the assembly on the global cost. With Bombardier data, he analyzes the estimated reduction cost if tolerance value rises. The idea is to reduce the manufacturing cost by enhanced tolerance values. Even if a second study gives the estimation functional requirement losses because of the enhancement of tolerance values, nothing shows how joints are specified and it could be a significant parameter about manufacturing cost.

The following work focuses on the definition of a functional datum reference frame and the expressions of aerodynamic requirements by specifying a complex surface and how to write this kind of specifications. This paper does not deal with the calculation of tolerance value.

## 2. Global form specification of a complex surface

### 2.1. Main datum reference frame

The main stage of the part tolerancing is the definition of the datum reference frame, A and B, corresponding to the setting-up surfaces taking into account degrees of freedom removed by each surface.

On Coordinate Measuring Machine, this datum reference frame is associated to real surfaces to create a coordinate system corresponding to CAD mark (Fig 3.)

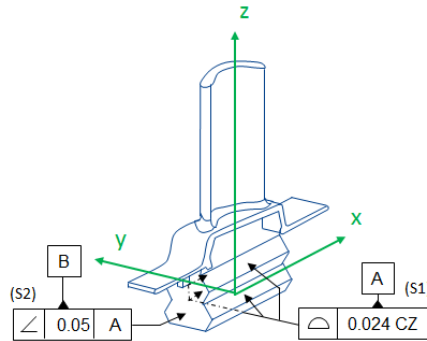

Figure 3: CAD mark on a turbine blade

This system gives the deviation between real points and the nominal model.

The tolerancing can be defined by CLIC method [4] [5].

Specification of profile form of surface A in common zone (S1) assures the quality of the contact of the primary surface.

The inclination of the secondary surface B (S2) assures the location of the blade.

### 2.2. General tolerancing

All surfaces of the part can be specified by a profile of all surfaces of the part with a wide global tolerance, in relation with the main datum reference frame.

This specification assures a maximal material condition of the part that avoids interference with adjacent parts and limits the weight of the part. A minimal condition to guaranties a minimum thickness of parts.

This tolerancing is sufficient for simple parts, but it is often necessary to add other specifications for functional surfaces and other junctions with other parts.

A specification of profile form of the blade airfoil portion can be added to define these functional surfaces on a restricted zone.

Fig. 4 illustrates the concept of general tolerancing with the comment "All surfaces" (S1). On the other hand, the form specification uses the "All around symbol" (a circle) and a collection plane C, which means that the specification (S2) is applied to all surfaces cut by a plane parallel to C located by the leader. In CAD environment, the portion of selected surface will be highlighted.

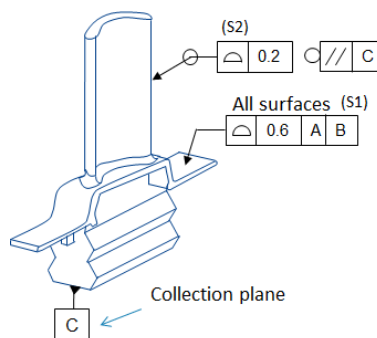

Figure 4: General form tolerancing

### 3. Connection specifications

#### 3.1. Outcrop between parts

When a complex surface is defined on two parts, the outcrop between parts is an important issue (Fig. 5) [3].

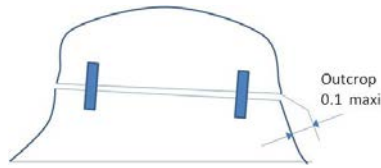

Figure 5: Outcrop between 2 parts

Figure 6 illustrates the specifications (S1) and (S2) of parts considering the continuity requirement on a restricted zone near the boundaries of surfaces.

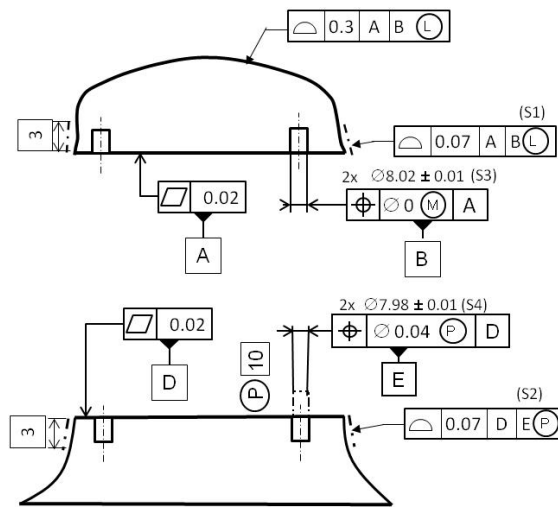

Figure 6: Tolerancing of the outcrop

Maximal outcrop variation is equal to the sum of tolerances (S1 and S2) and of the maximal clearance defined by minimal material dimensions of the link between parts (S3 and S4).

#### 3.2. Connection fillet

The form specification is not relevant for fillet, because, the tolerance zone accepts very small or very large radius (Fig. 7).

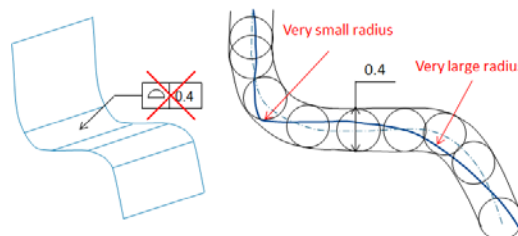

Figure 7: Continuous tolerance zone

The classical notion of radius is preferable, with a tolerance zone defined between minimal and maximal acceptable radius.

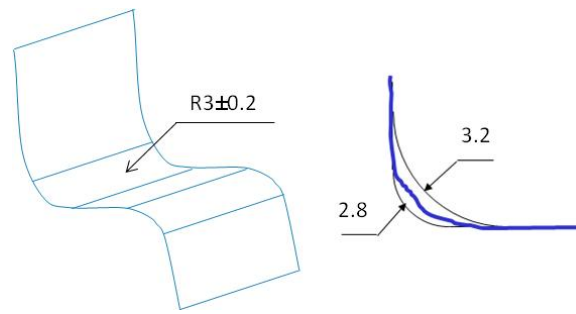

Figure 8: Radius tolerance

#### 4. Aerodynamic profile specifications

##### 4.1. Profile of a line

Depending on the environment of the mechanism, the complex surface may require more stringent constraints than the general tolerancing.

This problem is illustrated on a blade which requires a quality profile in a plane which corresponds to the flow of the air stream. Plane C (Fig. 4) is now used as an intersection plane for specification of profile of a curve (Fig. 9).

This specification ensures the form and orientation of each section, independently of the other sections. In practice, the thickness of the blade is severe enough, by cons, the leading and trailing edges can be longer or shorter.

Similarly, the trailing edge cannot have breaks to properly guide the air flow. The form of the trailing edge and the leading edge must be perfect to minimize losses.

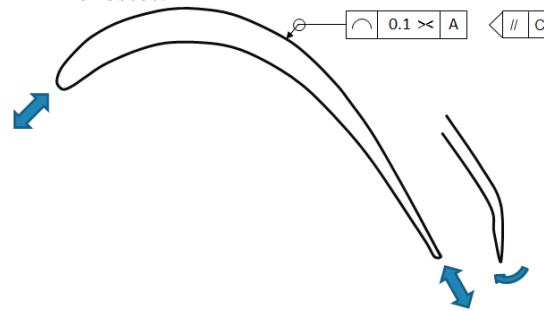

Figure 9: Global tolerancing of sections

##### 4.2. Splitting of a profile

Aero-dynamic requirements concern several portions of a complex surface with smallest tolerances. So with the aim of only specifying these functional requirements; the profile is split.

The splitting of the profile implies that form specifications (S1) of the trailing or the leading edge (Fig. 10) are free to move away from the center of the profile. These surfaces must respect specification all around the profile with largest tolerance (S2).

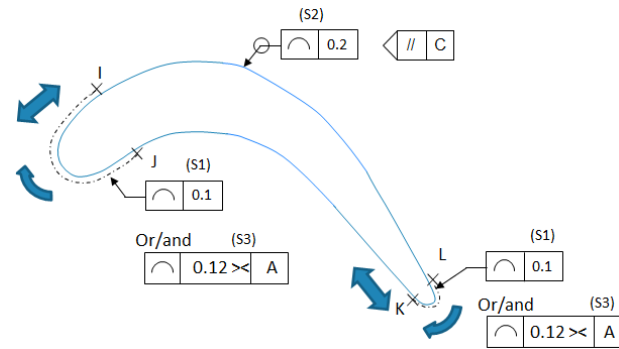

Figure 10: Control of the edge positions; Example of a splitting profile of a blade

To control the orientation of trailing and leading edge, orientation specification can be added (S3).

#### 4.3. Datum reference on complex surface

To control the breaking down of the trailing edge, the first idea is to create a datum reference on central portion of the blade to locate the extremity of the trailing edge.

Figure 11 presents datum A (S1) on surface defined as nominal surface tangent to the real surface that minimizes the maximal distance. In this case, the surface is quite circular. The orientation with respect to a circle does not make sense. Both specifications (S1) and (S2) are independent. The relative location and orientation of these two portions are not assured.

Datum B is defined on a bilateral surface. It is a nominal surface that minimizes the maximal distance with the real surface. In this case, the thickness decreases along the surface. So, the datum moves to reduce the distance with part. Specification (S3) depends on the thickness of the part.

These two surfaces A and B are not acceptable to create datum. The datum cannot be constructed if the normals of the surface are quite concurrent.

Datum C is created by three datum targets. The nominal line can slide on points C1 and C2. Target C3 must be perpendicular to this sliding direction. Specification (S4) can be specified relative to the C datum.

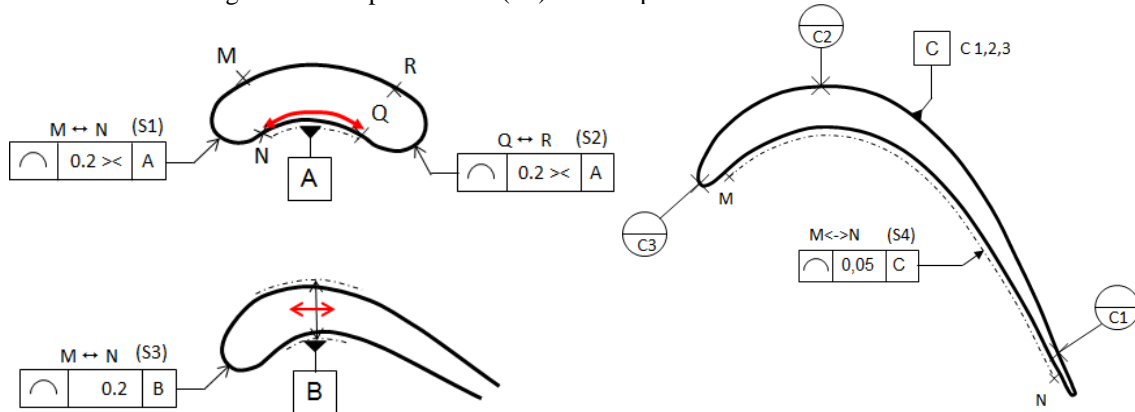

Figure 11: Datum reference on complex surface

To control the breaking down of trailing edge and the thickness of the blade, a better solution consists in the association of both surfaces in a common tolerance zone. As specification (s2) (Fig. 12), common tolerance zone keeps the orientation of the reference element and limits the defect on the specified element.



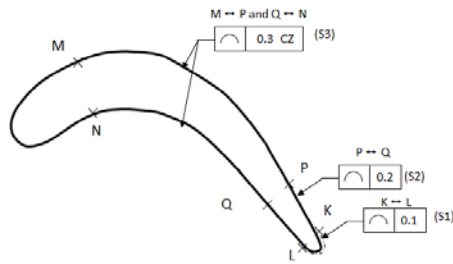

Figure 12: Common zone specifications

The common zone (s3) locks the orientation; however it locks the relative position between the two elements too. It could be useful to control the thickness of the blade, as specifications (s2) and (s3).

#### 4.4. Local defects

Frequently, functions of complex surfaces are esthetical or aero-dynamical. Micro defects are forbidden.

Specifications with mobile tolerance zone limit these local defects by analyzing all small portions of the surface with strict tolerances (Fig. 13).

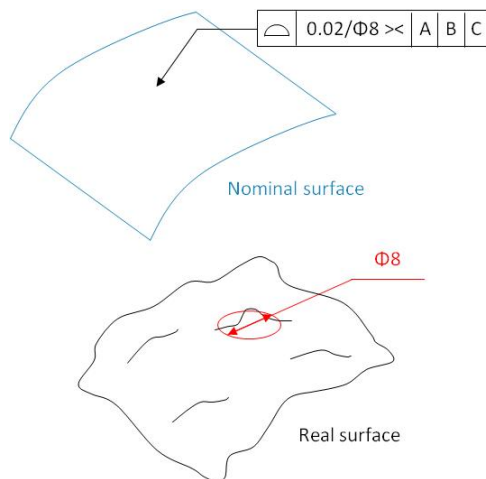

Figure 13: Local defects tolerancing

It is possible to specify different kinds of tolerance zone shape. It is possible to define a circle or a rectangle:

- 8x8: Square with 8 mm sides
- Φ8: Circle with 8 mm diameter

A mobile tolerance zone specification needs the modifier “><”, introduced in section 1.3, because the tolerance zone is small and it is dangerous to let the orientation free during the association between the real surface and the CAD model. The optimization is made only with a translation along the normal of the surface on this studied point.

The following figure illustrates this issue (Fig. 14).

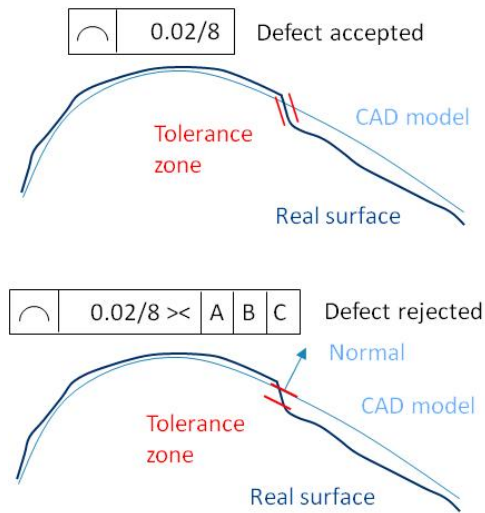

Figure 14: Problem of mobile tolerance zone

## 5. Variable tolerance

### 5.1. State of the ISO Standard

With the aim of reducing the number of specifications and improve the comprehension of the tolerancing it could be relevant to use variable tolerances.

Variable tolerances are defined by the ISO 1101: 2013 [1] standard (Fig. 15), which only presents a 2D case.

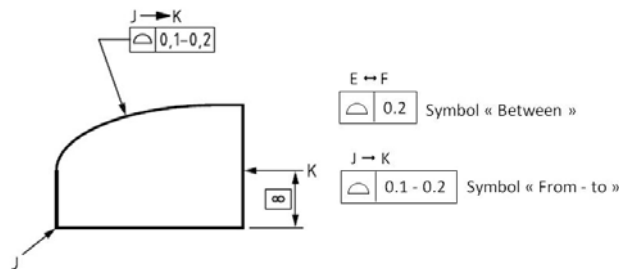

Figure 15: Extract of ISO 1101: 2013 standard

With a simple arrow, the variation of tolerance is linear from 0.1 to 0.2 between boundaries J and K. The double arrow symbol indicates that the tolerance is constant between the boundaries.

### 5.2. Proposition of standardized writing

To go further from the ISO standard the tolerance of the surface would become entirely 3D by extending the possibility to make the tolerance vary on all boundaries of the complex surface. It implies to define a tolerance value at all points which define the boundaries (Fig. 16).

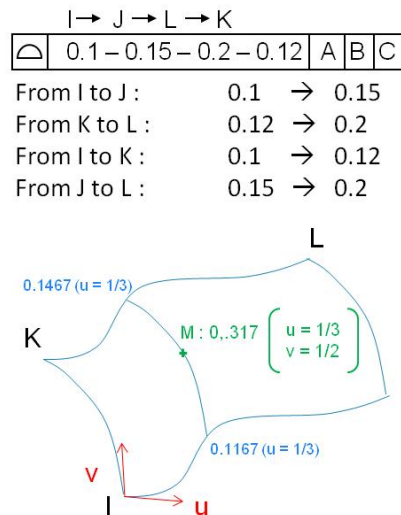

Figure 16: Standardized writing proposition

In a first step the evolution between points stays linear, but it is easy to imagine another step where the evolutions between the extremities of the boundaries are non linear with function in nota.

This 3D evolution of the ISO definition of variable tolerance coupled with a large cloud of points, obtained by an optical measurement tool for example, allows the designer to check immediately the conformity of a part with a high precision. With the notion of variable tolerance the continuity of the tolerance zone is preserved.

## 6. Conclusion

The multi-scale approach seems to be a relevant solution to analyze the way of tolerancing a complex surface or line.

It is necessary to start the part tolerancing with the functional datum reference frame built on the setting-up surfaces which gives the general form and position, and look more precisely for the orientation of the surfaces and connections between them. The next step is to split surfaces to answer particular needs and finally specify local defects.

A complementary tool which could include some of the previous specifications is variable tolerance. It permits to reduce the number of specifications and make a continuous tolerance zone.

Except for variable tolerances, the ISO standards give enough tools to specify all kinds of complex surfaces requirements. Therefore methods presented in this paper can be applied to all kind of parts and respect the ISO standard.

## Acknowledgements

The authors want to thank Snecma for all information it has shared with them. This work has been funded by a CIFRE contract with Snecma company and LURPA laboratory.

## References

- [1] ISO 1101. (2013). International organization for standardization, geometrical tolerancing - tolerancing of form, orientation, location and run-out-generalities, definitions, symbols, indications on drawings.
- [2] ISO 5459. (2011). Geometrical product specifications (GPS), Datums and datum systems for geometrical tolerancing
- [3] Mejri H., Anselmetti B., Mawussi K. (2005), Functional tolerancing of complex mechanisms: Identification and specification of key parts.
- [4] Anselmetti B. (2008) CLIC method, « Tolérancement » volume 3: Editions Hermes Sciences, Lavoisier.
- [5] Anselmetti B. (2006), Generation of functional tolerancing based on positioning features.
- [6] Zhang M. (2011), Discrete Shape Modeling for Geometrical Product Specifications: Contributions and Applications to Skin Model Simulation, thesis.
- [7] Ballu A., Mathieu L. (1995), Univocal expression of functional and geometrical tolerances for design, manufacturing and inspection, Computer Aided Tolerancing, 4<sup>th</sup> CIRP Seminar, Japan, 31-46.

- [8] Mathieu L., Ballu A. (2003), GEOSPELLING: a common language for Geometrical Product Specification and Verification to express method uncertainty. Proceedings of the 8<sup>th</sup> CIRP Seminar on Computer Aided Tolerancing, Charlotte, USA, April.
- [9] Chiabert P., Lombardi F., Orlando M. (1998), Benefits of geometric dimensioning and tolerancing.
- [10] Curran R., Kundun A., Raghunathan S., Eakin D., McFadden R. (2003), Influence of manufacturing tolerance on aircraft direct operating cost (DOC).