



HAL
open science

Systematic LFT Derivation of Uncertain Electrical Circuits for Worst-Case Tolerance Analysis

Moises Ferber de Vieira Lessa, Anton Korniienko, Gérard Scorletti, Christian Vollaire, Florent Morel, Laurent Krähenbühl, Joao Antonio Vasconcelos

► **To cite this version:**

Moises Ferber de Vieira Lessa, Anton Korniienko, Gérard Scorletti, Christian Vollaire, Florent Morel, et al.. Systematic LFT Derivation of Uncertain Electrical Circuits for Worst-Case Tolerance Analysis. [Research Report] Laboratoire Ampère CNRS UMR 5005, Université de Lyon, INSA - Lyon. 2014. hal-01073934

HAL Id: hal-01073934

<https://hal.science/hal-01073934>

Submitted on 10 Oct 2014

HAL is a multi-disciplinary open access archive for the deposit and dissemination of scientific research documents, whether they are published or not. The documents may come from teaching and research institutions in France or abroad, or from public or private research centers.

L'archive ouverte pluridisciplinaire **HAL**, est destinée au dépôt et à la diffusion de documents scientifiques de niveau recherche, publiés ou non, émanant des établissements d'enseignement et de recherche français ou étrangers, des laboratoires publics ou privés.

Technical Report:

Systematic LFT Derivation of Uncertain Electrical Circuits for Worst-Case Tolerance Analysis

Moises Ferber*[†], Anton Korniienko*, Gérard Scorletti*, Christian Vollaire*, Florent Morel*, Laurent Krähenbühl*, João Antônio de Vasconcelos[†]

*University of Lyon, Ecole Centrale de Lyon

Ampere, CNRS UMR5005, 36 avenue Guy de Collongue, 69134 Ecully, France

Email: moisesferber@gmail.com

[†]Laboratorio de Computação Evolucionaria

Universidade Federal de Minas Gerais, Belo Horizonte, Brazil

Abstract

In line with the trend towards continuous miniaturization and price reduction, it is crucial to analyze the impact of uncertainties on the performance of electrical circuits. Performance is evaluated for the worst-case scenario and in the frequency domain, by computing upper and lower bounds. The purpose is not only to propose a method for the worst-case tolerance analysis but also to provide an efficient and a suitable tool for electrical engineers that can be easily applied to realistic electrical engineering problems. The proposed method is based on the robust analysis method (so-called μ -analysis) for which well-known and efficient algorithms exist. However in order to apply it, the problem under consideration has to be transformed in a standard minimal so-called LFT representation. Its derivation is a difficult task even for control systems engineers. Our paper proposes a transparent and systematic LFT derivation procedure for users based only on their knowledge of electrical engineering. At the end of the paper, an industrial example is provided which reveals the benefits and the efficiency of the proposed approach and how it can be applied to any linear electrical circuit.

Index Terms

Linear Fractional Transformation, Robustness analysis of circuits, uncertainty, worst-case analysis, μ -analysis, ν -analysis.

I. INTRODUCTION

Nowadays, the semiconductor industry continuously scales toward nanometer technologies while constantly increasing complexity and deep silicon integration of electrical circuits. Both important technological dispersions and increase of interconnection parameter variations can bring a significant degradation of electrical circuit performance. In order to design a reliable system, it is thus required to take these parameter variations into account and to ensure the *robust performance* of the circuit besides the *nominal* one. The robust performance *analysis* is the procedure allowing to test whether the system performance remains to be acceptable in front of possible parameter variations or model *uncertainties*.

There can be underlined two existing approaches to achieve the mentioned goal: (i) probabilistic and (ii) worst-case analysis methodologies. The first approach allows to determine the probability of robust performance based on the given probability density functions (PDF) over parameters [1]–[5]. The worst-case approach in its turn does not consider any probabilistic aspects and the performance criteria is analyzed for the worst combination of the uncertain parameters [3], [6]–[12]. It ensures the robust performance for all possible combination of the uncertain parameters.

In some critical applications such as cardiac stimulation chips, nuclear power plant control, automatic driving panels of vehicles, *etc.*, the ability to ensure the system performance in 100% of the cases is crucial. For these reasons, and due to the importance of such critical applications, the subject of this paper focuses on the worst-case tolerance analysis of electrical circuits. In this paper, only linear electrical circuit models are addressed. Even though the linearity assumption could appear restrictive, in a large number of applications, the linear model of an electrical circuit precisely describing the behavior of the system around an operation point can still be derived. Furthermore, the worst-case robust performance analysis even for the linear systems but with general (possibly large) size and structure is actually a challenging NP-hard problem [13]. This means that the execution time of the algorithm is a Non-Polynomial function of the number of uncertainties.

There is a number of approaches to evaluate the worst-case system performance. In many applications related to circuit theory, such as, for example, filter or phase locked loop (PLL) analysis, the performance is evaluated in the frequency domain. In this case, the robust system performance is assessed by computing upper and/or lower bounds on the frequency responses of some performance transfer functions. These transfer functions are chosen such that they reflect the performance measure of the circuit. For the filter example, the performance transfer function is the filter attenuation measure between filter inputs and outputs.

The main purpose of the present paper is to propose a method for the worst-case tolerance analysis of any linear electrical circuit systems. The proposed method operates in frequency domain and should be efficient in terms of computational time (time grows as a polynomial function relative to the number of uncertainties) such that it is applicable for large-scale systems.

The importance of the problem under consideration is illustrated by the growing number of publications in this field [3], [6]–[12]. However, as it was pointed out before, the computational complexity and time is the

main difficulty of the proposed solutions. In [6], [7] and [9], a methodology based on Interval Arithmetic (IA) is proposed. In order to simplify the computations, the authors enforce the assumption of monotonicity of the variable of interest with respect to the uncertain parameters. Transposing to the problem under consideration, it means that the frequency response magnitude of a filter can only grow if any of the uncertain parameters grows. This is a very strong assumption restricting the number of the electrical circuits that can be analyzed. In [7], the authors propose an alternative solution based on interval partitioning which is again inefficient in terms of the computation time for large-scale systems. Another approach improving the idea of interval partitioning based on constraint logic programming and Relational Interval Arithmetic (RIA) is proposed in [8]. However, as claimed by the authors, the algorithm for the worst-case tolerance analysis proposed in [8] has exponential complexity with respect to the number of uncertain parameters and therefore is inefficient.

In [10], genetic algorithms (GA) and affine arithmetic (AA) are used to improve the results obtained from IA and RIA. However, the computational complexity is still high for systems of significant size and therefore its usage is somehow limited. An interesting solution to relax the monotonicity assumption and decrease the computation time is to encapsulate the bounds by outer and inner solutions as presented in [12]. Nevertheless the authors in [12] consider only the steady states worst-case analysis and the dynamical aspects were put in perspective.

An interesting approach to address the problem considered in frequency domain is the μ -analysis methodology originally proposed in the control system theory community [14]–[16]. This methodology proposes to deal with the computation complexity by relaxing complex analysis conditions. It leads to the convex Linear Matrix Inequality (LMI) optimization framework [17] for which efficient computation algorithms are available nowadays. The same idea of outer (inner) solutions as in [12] is used to perform this relaxation so that the performance analysis result is still ensured in 100% of the cases. However, in contrast to [12], the μ -analysis can be applied for all frequencies which allows to include the dynamical system behavior and not only its steady states.

Nevertheless, though the μ -analysis method is usually accepted in the control theory community for the worst-case performance analysis, very few results were published on its application by the electronic engineering community. Few exceptions can be found in [18], [19]. We believe that there are two main reasons that could explain this fact. The first reason is that the μ -analysis method is a powerful theoretically based tool. It uses the control theory mathematical formalism which is not necessary the same as in the electrical engineering community and is rarely adapted to its practice. As a consequence, the interesting ideas are not understood and are not transmitted for practical use in electrical circuit systems. The second reason is that in order to apply the μ -analysis, as it will be presented in this paper, a particular system transformation is necessary. This particular representation of the transformed system is called Linear Fractional Transformation (LFT) or ΔM -representation. Once the LFT representation of the uncertain linear electrical circuit is derived, the application of robust worst-case performance analysis is a quite routine method based on the resolution of convex optimization problems involving LMI constraints.

For a typical automatic control application, it was proved that an LFT representation can be always obtained [20]. However, the choice of the LFT representation is not unique and the quality of the obtained result dramatically depends on this choice. In order to limit the computation burden and the numerical problems, an interesting choice

is to find the so-called minimal LFT representation, that is, the LFT representation of the smallest dimension. This point is important since for non-academic applications, without a rigorous methodology, an LFT representation of an unnecessary high size is usually obtained. Such non-academic applications include the real industrial electrical circuits with an important number of components and uncertain parameters as well as several hierarchical levels.

Unfortunately, except for very particular classes of problems, the computation of the minimal LFT representation is a difficult and open problem [21]. Nevertheless, in the applications of the automatic control community, when the uncertain system is represented by a block diagram, a procedure was proposed to obtain from this block diagram, an LFT representation of the smallest size [22]. In the case when the block diagram representation is a minimal representation of the uncertain system, which is usually the case when the block diagram is rigorously constructed, the procedure leads to the minimal LFT representation. Nevertheless, in the electrical engineering community, the models of linear electrical circuits are not expressed as block diagrams but as electrical schematic. Even if it is theoretically possible, for real industrial electrical circuits, the transformation of an electrical schematic into a block diagram is a heavy, time-consuming task and thus it is not practically possible. It is then important to propose an efficient procedure to obtain an LFT representation directly from an electrical schematic.

In the few existing results on the application of the μ -analysis to (uncertain) electrical circuit [18], [19], this crucial question was not addressed. The authors in [19] do not explain how to derive the LFT form, while in [18], the authors propose a manual and rather complex procedure based on matrix state space representations and block scheme interconnection that strongly depends on the example under consideration.

The main contribution of this paper is to propose a systematic procedure in order to obtain, for any linear electrical circuit, an LFT representation of reasonable dimension using the formalism of electrical schematic. Based on this representation, black-box procedures of the μ -analysis approach allow to investigate the worst-case performance analysis of arbitrary linear electrical circuits. The major benefit is that an electrical engineer can directly apply the μ -analysis to the worst-case tolerance analysis of arbitrary linear electrical circuits without special knowledge in control systems theory.

In section II, the problem formulation is given. In section III, based on the μ -analysis theoretical result, the worst case upper bound problem is solved. Then in section IV, the systematic LFT representation derivation procedure of reasonable dimension is presented. In section V, a general algorithm for worst case performance analysis is formulated and at the end of the paper, in section VI, an application numerical industrial example is presented. The article ends with a conclusion and further work discussions.

NOTATIONS AND DEFINITIONS

- Conjugate transpose of a matrix F is denoted by F^* ;
- Singular values σ_i of a complex $n \times m$ matrix F are defined as square roots of eigen values λ_i of the matrix F^*F if $n \geq m$ and FF^* if $n < m$ i.e. $\sigma_i(F) = \sqrt{\lambda_i(F^*F)}$ for $n \geq m$ or $\sigma_i(F) = \sqrt{\lambda_i(FF^*)}$ for $n < m$ [23];
- $\sigma_{max}(F)$ and $\sigma_{min}(F)$ stand for the maximum and minimal singular value of the complex matrix F ,

respectively. For scalar matrix F , i.e. $n = m = 1$, $\sigma_{max}(F) = \sigma_{min}(F) = |F|$;

- $\dim(w)$ denotes the dimension of the vector w ;
- I_n and $0_{n \times m}$ respectively denote an $n \times n$ identity and $n \times m$ zero matrices. The dimensions could be omitted if apparent from the context.

II. PROBLEM STATEMENT

A linear electrical component is a dipole for which voltage and current are linked by a linear differential equation with constant coefficients. A linear electrical circuit is a system of interconnected linear electrical components and of couplings between currents and/or voltages in various parts of the circuit such as mutual inductors, controlled voltage sources... (see Table I). Usually these circuits are described as a schematic including elementary dipoles (resistors, inductors, capacitor) and couplings. Each of these elements is described by a parameter. For nominal parameters, electric circuit simulators can easily compute the nominal performance of the circuit in the frequency domain, that is, the magnitude of the frequency response between the circuit input and the circuit output. If the parameters are known as a nominal value and a given level of uncertainty, in order e.g. to ensure conformity to standards, the circuit designer has to evaluate the worst-case performance defined as, for a given frequency, the range of the magnitude of the frequency response for any possible values of the circuit parameters.

As pointed out in the introduction and as detailed in the next section, μ -analysis can be applied to compute lower bound and upper bound on these range if the circuit with its uncertain parameters is expressed using an LFT representation, derivation of which is a difficult task.

The problem under consideration is to extend the usual electrical schematic from the representation of "nominal" electrical circuits to "uncertain" ones such that an LFT representation of reasonable size is systematically obtained in order to evaluate the worst-case performance.

To solve this problem, let us proceed in two steps. Firstly, in the next section, the problem of worst-case tolerance analysis is introduced and its efficient solution is presented based on the existing results in control theory. This step allows to illustrate how the LFT representation is used for the worst-case tolerance analysis and to underline the importance of its systematic derivation. Secondly, in section IV, a solution of the problem of the LFT representation derivation is proposed by introducing a library of "uncertain components" in addition to the usual library of "nominal components" of the electrical schematic.

III. WORST-CASE TOLERANCE ANALYSIS PROBLEM

A. Problem formulation

Let us introduce the problem of electrical circuits worst-case tolerance analysis. For this purpose, the linear electrical circuit is modeled by a transfer function $T_{w_p \rightarrow z_p}(s)$ such that

$$z_p(s) = T_{w_p \rightarrow z_p}(s)w_p(s)$$

where $z_p(s)$ denotes the Laplace transform of the system output, $w_p(s)$ the Laplace transform of the system input and $T_{w_p \rightarrow z_p}(s)$ is such that with $p = (p_1, \dots, p_N)$ the vector of the N parameters of the linear electrical circuit:

$$T_{w_p \rightarrow z_p}(s) = \frac{\sum_{j=0}^m b_j(p) s^j}{\sum_{i=0}^n a_i(p) s^i}. \quad (1)$$

The coefficients a_i and b_j of the transfer function $T_{w_p \rightarrow z_p}$ are in general rational functions of the N parameters of the linear electrical circuit:

$$a_i(p) = a_i(p_1, \dots, p_N) \quad \text{and} \quad b_j(p) = b_j(p_1, \dots, p_N).$$

which are designed such that the transfer function frequency response $T_{w_p \rightarrow z_p}(j\omega)$ satisfies some performance specifications.

Unfortunately, due to production or ageing etc. dispersions, the actual value of the parameters p is different from the designed value p^0 . A more adequate modeling is then to assume that each parameter p_k belongs to an interval:

$$p_k \in [p_k^{min}, p_k^{max}]. \quad (2)$$

The center of the interval $p_k^0 = \frac{p_k^{max} + p_k^{min}}{2}$ is referred to as the nominal value. If the actual value of p_k is not known, the lower bound p_k^{min} and the upper bound p_k^{max} are a priori known. They are usually expressed as relative expression of the nominal value p_k^0 , e.g.:

$$p_k = p_k^0 \pm 50\%.$$

The question is then to evaluate for any frequency ω the range of variation of $|T_{w_p \rightarrow z_p}(j\omega)|$ for any $p_k \in [p_k^{min}, p_k^{max}]$. This question can be decomposed into two different problems: the worst-case upper bound problem and the worst-case lower bound problem.

WORST-CASE UPPER BOUND PROBLEM

Given $T_{w_p \rightarrow z_p}$, p_k^{min} and p_k^{max} , for a given frequency ω compute the smallest $\eta(\omega)$ such that for any $p_k \in [p_k^{min}, p_k^{max}]$

$$|T_{w_p \rightarrow z_p}(j\omega)| \leq \eta(\omega).$$

Another interesting problem is the computation of the worst-case lower bound on the frequency response of the transfer function $T_{w_p \rightarrow z_p}$: given $T_{w_p \rightarrow z_p}$, p_k^{min} and p_k^{max} , for a given frequency ω compute the largest $\beta(\omega)$ such that for any $p_k \in [p_k^{min}, p_k^{max}]$

$$\beta(\omega) \leq |T_{w_p \rightarrow z_p}(j\omega)|.$$

Nevertheless in the sequel, we focus on the WORST-CASE UPPER BOUND PROBLEM since the worst-case lower bound problem can be recast as an equivalent WORST-CASE UPPER BOUND PROBLEM with the upper bound $\hat{\eta}(j\omega)$ defined as $\frac{1}{\beta(\omega)}$ and the transfer function $\hat{T}_{w_p \rightarrow z_p}$ defined as $T_{w_p \rightarrow z_p}^{-1}$.

In the case when $z_p(s)$ and $w_p(s)$ are vectors (with $n_z = \dim(z_p)$ and $n_w = \dim(w_p)$) i.e. Multi-Input Multi-Output (MIMO) case, $T_{w_p \rightarrow z_p}(s)$ previously defined by (1) is now a matrix of transfer functions. The formulation of the WORST-CASE UPPER BOUND PROBLEM is extended as follows.

MIMO WORST-CASE UPPER BOUND PROBLEM

Given $T_{w_p \rightarrow z_p}$, p_k^{min} and p_k^{max} , for a given frequency ω compute the smallest $\eta(\omega)$ such that for any $p_k \in [p_k^{min}, p_k^{max}]$

$$\sigma_{max}(T_{w_p \rightarrow z_p}(j\omega)) \leq \eta(\omega).$$

As in the single input, single output case, another interesting problem is the computation of the worst-case lower bound on the frequency response of the transfer function $T_{w_p \rightarrow z_p}$: given $T_{w_p \rightarrow z_p}$, p_k^{min} and p_k^{max} , for a given frequency ω compute the largest $\beta(\omega)$ such that for any $p_k \in [p_k^{min}, p_k^{max}]$

$$\beta(\omega) \leq \sigma_{min}(T_{w_p \rightarrow z_p}(j\omega)).$$

Nevertheless, in the sequel and for the same reasons as previously, we focus on the MIMO upper bound case only. In the next subsection, we reveal how the MIMO WORST-CASE UPPER BOUND PROBLEM is solved using robust control approach.

B. Robust Worst-case Performance Analysis

According to (2), the uncertain parameters can be expressed as a sum of two parts: (i) the nominal part p_k^0 and (ii) the uncertain part $p_k^0 p_k^g \delta_k$:

$$p_k = p_k^0 (1 + \delta_k p_k^g) \quad (3)$$

where $p_k^0 = \frac{1}{2} (p_k^{max} + p_k^{min})$ denotes the nominal or center parameter value, $p_k^g = \frac{p_k^{max} - p_k^{min}}{p_k^{max} + p_k^{min}}$ the relative value of the uncertainty¹ (for 50% $\rightarrow p_k^g = 0.5$) and δ_k is the corresponding normalized uncertainty $|\delta_k| \leq 1$.

The transfer function $T_{w_p \rightarrow z_p}$ defined by (1) can then be expressed as:

$$T_{w_p \rightarrow z_p}(s) = \frac{\sum_{j=0}^m \widehat{b}_j(\delta_1, \dots, \delta_N) s^j}{\sum_{i=0}^n \widehat{a}_i(\delta_1, \dots, \delta_N) s^i}. \quad (4)$$

As the coefficients $\widehat{a}_i(\delta_1, \dots, \delta_N)$ and $\widehat{b}_j(\delta_1, \dots, \delta_N)$ are rational functions of $\delta_1, \dots, \delta_N$, $z_p(s) = T_{w_p \rightarrow z_p}(s) w_p(s)$ can always be transformed as [20]:

$$\begin{bmatrix} z(s) \\ z_p(s) \end{bmatrix} = M(s) \begin{bmatrix} w(s) \\ w_p(s) \end{bmatrix} \quad \text{and} \quad w(s) = \Delta(s) z(s) \quad (5)$$

¹In (3), the relative uncertainty representation is introduced in order to limit the numerical problems during the further computations. However the absolute uncertainty form can be used as well.

where Δ is defined by

$$\Delta = \begin{bmatrix} \delta_1 I_{n_1} & 0 & 0 \\ 0 & \ddots & 0 \\ 0 & 0 & \delta_N I_{n_N} \end{bmatrix}$$

with n_i defining the number of repetitions of uncertain parameter δ_i in the uncertain circuit model.

This representation, denoted² as $\Delta \star M$, is referred to as a Linear Fractional Transformation (LFT) representation of the linear electrical circuit. This representation can be interpreted as the feedback interconnection of the nominal part M (usually designed to be stable) and the unknown part Δ , see Fig.1.

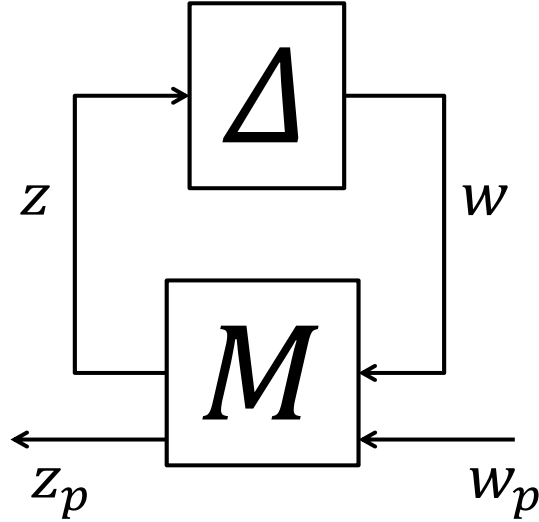

Fig. 1. LFT representation of the linear electrical circuit

Let us introduce the uncertainty set $\underline{\Delta}$ defined as:

$$\underline{\Delta} = \left\{ \Delta \mid \Delta = \begin{bmatrix} \delta_1 I_{n_1} & 0 & 0 \\ 0 & \ddots & 0 \\ 0 & 0 & \delta_N I_{n_N} \end{bmatrix}, \begin{array}{l} \forall k, \\ |\delta_k| \leq 1, \\ \delta_k \in \mathbb{R} \end{array} \right\} \quad (6)$$

The MIMO WORST-CASE UPPER BOUND PROBLEM can then be expressed as for a given ω : compute the smallest $\eta(\omega)$ such that for any $\Delta \in \underline{\Delta}$,

$$\sigma_{max}(\Delta \star M(j\omega)) \leq \eta(\omega).$$

This problem referred to as the robust performance problem was largely investigated in the Automatic Control community. A solution is presented in the following theorem.

²The symbol \star denotes the Redheffer star product, see *e.g.* [20].

Theorem 1 (MIMO case, [24], Theorem 2.1): For stable nominal system $M(s)$, for all possible $\Delta \in \underline{\Delta}$, for a given ω

$$\sigma_{max}(\Delta \star M(j\omega)) < \eta(\omega)$$

if and only if there exists an hermitian matrix $\Phi(j\omega) : \Phi^*(j\omega) = \Phi(j\omega)$ such that³

$$(i) \quad \forall \Delta \in \underline{\Delta}, \begin{bmatrix} I \\ \Delta \end{bmatrix}^* \begin{bmatrix} \Phi_{11} & \Phi_{12} \\ \Phi_{12}^* & \Phi_{22} \end{bmatrix} \begin{bmatrix} I \\ \Delta \end{bmatrix} \geq 0 \quad (7)$$

and

$$(ii) \quad \begin{bmatrix} M \\ I \end{bmatrix}^* \begin{bmatrix} \Phi_{11} & 0 & \Phi_{12} & 0 \\ 0 & I_{n_z} & 0 & 0 \\ \Phi_{21} & 0 & \Phi_{22} & 0 \\ 0 & 0 & 0 & -\eta^2 I_{n_w} \end{bmatrix} \begin{bmatrix} M \\ I \end{bmatrix} \leq -\epsilon I \quad (8)$$

with $\epsilon > 0$

Based on this Theorem, the solution of WORST-CASE UPPER BOUND PROBLEM is readily obtained, see the following Corollary.

Corollary 1 (SISO case): For stable nominal system $M(s)$ and for all possible $\Delta \in \underline{\Delta}$, for a given ω :

$$|\Delta \star M(j\omega)| < \eta(\omega)$$

if and only if there exists an hermitian matrix $\Phi(j\omega) : \Phi^*(j\omega) = \Phi(j\omega)$ such that (7) and (8) are satisfied with $n_z = n_w = 1$.

C. Computational Application of Theorem 1 and Corollary 1

For a given frequency ω , the application of Theorem 1 (respectively Corollary 1) allows to exactly find the upper bound $\eta(\omega)$ on the maximum singular value (frequency response magnitude) of $T_{w_p \rightarrow z_p}$ for MIMO (resp. SISO) case by computing an appropriate matrix $\Phi(j\omega)$ such that conditions (7) and (8) are satisfied.

However, it turns out that testing condition (7) is a difficult problem. Indeed, condition (7) has to be tested for all possible uncertainty Δ in the set $\underline{\Delta}$, *i.e.* an optimization problem involving an infinite number of constraints. In order to obtain an efficient computation, the optimization problem is modified by

- 1) parametrizing *i.e.* defining a set $\underline{\Phi}$ of matrices $\Phi(j\omega)$ for which the condition (7) is always satisfied;
- 2) testing the condition (8) for all $\Phi(j\omega)$ from this set *i.e.* for all $\Phi(j\omega) \in \underline{\Phi}$.

In the case of a set $\underline{\Phi}$ which is affine or defined by LMI constraints, the constraint (8) of Theorem 1 defines a convex optimization problem involving a finite number of LMI constraints which is efficiently solved in polynomial time. Nevertheless, this optimization problem computes an upper bound $\bar{\eta}(\omega)$ on $\eta(\omega)$ instead of computing $\eta(\omega)$ itself. The consequence is a possible conservatism of the obtained result *i.e.* $\bar{\eta}(\omega)$ can be far away from $\eta(\omega)$. However, thanks to an appropriate choice of the parametrization set $\underline{\Phi}$, the conservatism can be significantly reduced.

³The dependency on $j\omega$ (and on ω) is dropped for simplicity of notation.

It is clear that the set $\underline{\Phi}$ depends on the uncertainty set $\underline{\Delta}$ and the better it describes the uncertainty throughout (7) the closer the relaxed upper bounds $\bar{\eta}(\omega)$ to the real ones $\eta(\omega)$ are. For our problem, a suitable set $\underline{\Phi}$ is defined⁴ by:

$$\underline{\Phi} = \left\{ \Phi \mid \Phi = \begin{bmatrix} D_1 & & 0 & G_1 & & 0 \\ & \ddots & & & \ddots & \\ 0 & & D_N & 0 & & G_N \\ -G_1 & & 0 & D_1 & & 0 \\ & \ddots & & & \ddots & \\ 0 & & -G_N & 0 & & D_N \end{bmatrix} \right\} \quad (9)$$

with D_i and G_i are complex, full, $n_i \times n_i$ hermitian and respectively skew hermitian frequency depending matrices *i.e.* $D^* = D$ and $G^* = -G$. It is so called D, G -scaling for the case of real uncertainties δ_i used in μ -analysis [14], [15]. For these reasons, the use of the Theorem 1 with structure of Φ defined by (9) can be interpreted in terms of standard μ -analysis.

Finally, the computation of the upper bounds (close to the real upper bounds) is thus achieved by solving for each frequency ω the following convex optimization problem under LMI constraints:

$$\begin{aligned} \min_{\eta^2, \Phi} \eta^2 \\ \text{subject to (8) for } \Phi \in \underline{\Phi} \text{ defined by (9)} \end{aligned} \quad (10)$$

The program solving the optimization problem (10) in Matlab environment, providing the Robust Toolbox is included in Matlab distribution, is available online on the website [25].

The MIMO WORST-CASE UPPER BOUND PROBLEM can be therefore efficiently solved in order to apply the worst-case performance analysis of the linear electrical circuit. However, this is possible only in the case when the LFT representation (5) corresponding to the electrical circuit is available. The next section presents how to obtain the LFT representation of reasonable size starting from the electrical circuit schematic.

IV. SYSTEMATIC LFT DERIVATION

In this section, a method of systematic LFT derivation for general linear uncertain electrical circuits is presented. This is the crucial step to solve the worst-case tolerance analysis problem and, as discussed in the introduction, it is a difficult problem. In this paper, the following interesting idea is used to overcome this issue. When a designer is constructing the model of an electrical circuit with an arbitrary software⁵, interconnecting the library components together, creating and interconnecting then the subsystems in hierarchical way etc., he is actually building at the same time the LFT representation of the circuit with a minimal number of components. The only question is: how to extract this LFT representation (see $\Delta \star M$ in (5)) from the electric circuit model? For this purpose, once the

⁴The dependency on $j\omega$ (and on ω) is dropped for simplicity.

⁵The example presented is SimPowerSystemsTMtoolbox.

electric circuit model is built, first the traditionally used component models (such as resistor, capacitor, inductor models etc.) are replaced by uncertain component models proposed in this section. The number and the ordering of these uncertain components automatically define the structure of the block Δ . Then, the extraction procedure is performed in order to obtain the matrix transfer function $M(s)$.

In the following subsection, a library of elementary uncertain linear electric circuit components is proposed. Since these uncertain components are very similar to the standard ones, there is only the need of regular electrical engineer's knowledge to use (and build) the uncertain model. It is even possible to combine the regular and uncertain components in order to avoid time consuming computation in the case where some uncertainties can be neglected. Then, in next subsection, the procedure of LFT representation extraction is presented.

A. Block Diagram of Uncertain Electrical Components

The detailed description of the uncertain components is given only for Resistor, Capacitor and Mutual Inductor while other components can be deduced in a similar fashion. A more complete table (or library) of uncertain components is then presented.

1) *Resistor*: the equivalent circuit of the normalized uncertain resistor is presented in the first line of the Table. I, where R_g is the unit less normalization factor, R_0 is the resistor nominal value (Ω), δ_R is a real number such that $|\delta_R| < 1$, z_R is the uncertain output, w_R is the uncertain input, i_R is the current that flows through the resistor and v_R is the voltage drop across the resistor.

Note that the voltage seen by the terminals + and - of the circuit is the voltage drop on the resistor R_0 plus the voltage of the source in series with the resistor, which is given by $R_0 i_R R_g \delta_R$. The total voltage drop between terminals + and - of the circuit is given by (11). Hence, the equivalent resistance of the circuit corresponds exactly to the normalized relative form of uncertain parameter introduced in (3).

2) *Capacitor*: the equivalent circuit of the normalized uncertain capacitor is presented in the second line of Table I.

Note that the current that flows through the terminals + and - of the circuit is the current that flows through the capacitor C_0 plus the current that is injected by the source in parallel with the capacitor C_0 , which is given by $C_0 \frac{dv_C}{dt} C_g \delta_C$. The total current of the circuit is given by (12). Hence, the equivalent capacitance of the circuit exactly corresponds to the normalized relative form of uncertain parameter introduced in (3).

3) *Mutual Inductor*: the equivalent circuit of the normalized uncertain mutual inductor is presented in the eighth line of Table I.

Note that the voltage v_1 seen by the terminals + and - in the left part of the circuit is the voltage drop on the inductor L_1 , which is given by $L_1 \frac{di_{L_1}}{dt}$, plus the voltage drop on the Mutual Inductor M_0 , which is given by $-M_0 \frac{di_2}{dt}$ and plus the voltage of the source in series with M_0 , which is given by $-M_0 \frac{di_2}{dt} M_g \delta_M$. Thus, the total voltage v_1 in the left part of the circuit is given by (13).

The procedure for obtaining v_2 is analogous. All other uncertain components from the proposed library are obtained in similar fashion and are presented in the Table I.

TABLE I
UNCERTAIN COMPONENT LIBRARY

Component	Equivalent circuit
<p style="text-align: center;">Resistor</p> $v_R^{tot} = R_0 i_R + R_0 i_R R_g \delta_R = R_0 (1 + R_g \delta_R) i_R \quad (11)$	
<p style="text-align: center;">Capacitor</p> $i_C^{tot} = C_0 \frac{dv_C}{dt} + C_0 \frac{dv_C}{dt} C_g \delta_C = C_0 (1 + C_g \delta_C) \frac{dv_C}{dt} \quad (12)$	
<p style="text-align: center;">Inductor</p> $v_L^{tot} = L_0 \frac{di_L}{dt} + L_0 \frac{di_L}{dt} L_g \delta_L = L_0 (1 + L_g \delta_L) \frac{di_L}{dt}$	
<p style="text-align: center;">Conductor</p> $i_G^{tot} = G_0 v_G + G_0 v_G G_g \delta_G = G_0 (1 + G_g \delta_G) v_G$	
<p style="text-align: center;">Controlled Voltage Source</p> $v_{CS} = v_{in} + v_{in} v_g \delta_v = (1 + v_g \delta_v) v_{in}$	

TABLE I
UNCERTAIN COMPONENT LIBRARY (CONTINUE)

Component	Equivalent circuit
<p>Controlled Current Source</p> $i_{CS} = i_{in} + i_{in}i_g\delta_i = (1 + i_g\delta_i)i_{in}$	
<p>Mutual Inductor</p> $\begin{aligned} v_1 &= L_1 \frac{di_1}{dt} - M_0 \frac{di_2}{dt} - M_0 \frac{di_2}{dt} M_g \delta_M \\ &= L_1 \frac{di_1}{dt} - M_0(1 + M_g \delta_M) \frac{di_2}{dt} \\ v_2 &= L_2 \frac{di_2}{dt} - M_0 \frac{di_1}{dt} - M_0 \frac{di_1}{dt} M_g \delta_M \\ &= L_2 \frac{di_2}{dt} - M_0(1 + M_g \delta_M) \frac{di_1}{dt} \end{aligned} \quad (13)$	

B. LFT extraction

In the last subsection, equivalent uncertain linear electrical circuits for uncertain linear components were developed. All these equivalent circuits have electrical terminals, for the usual electrical connections, but also two or four uncertain terminals, an input w_x and output z_x , which should be connected to the uncertain block Δ .

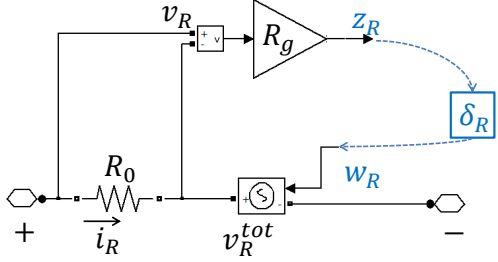
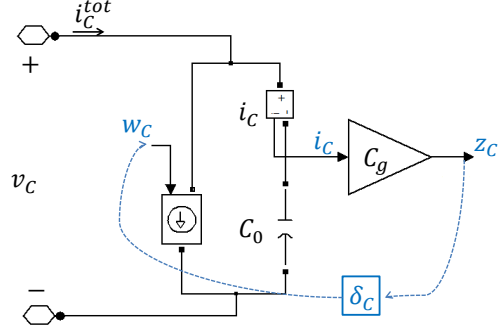
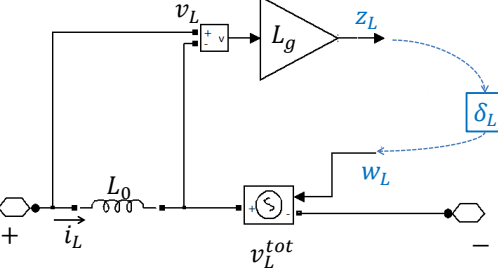
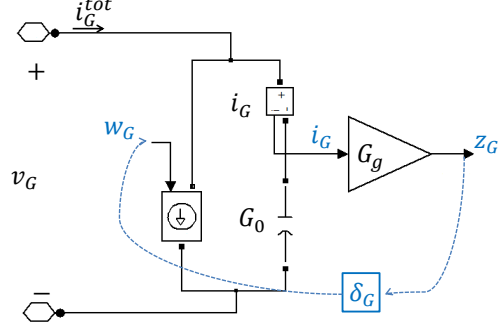
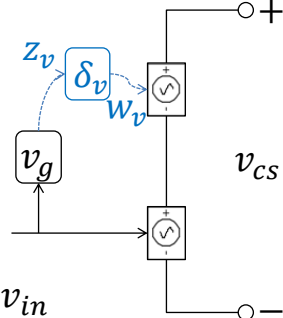
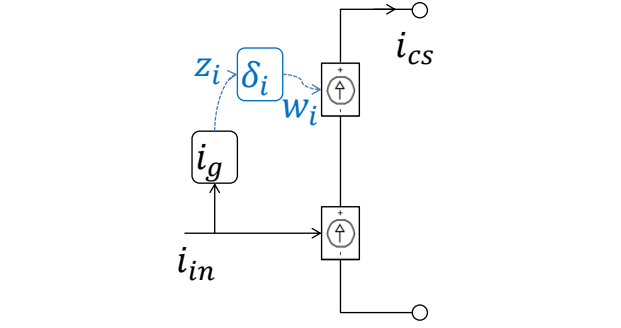
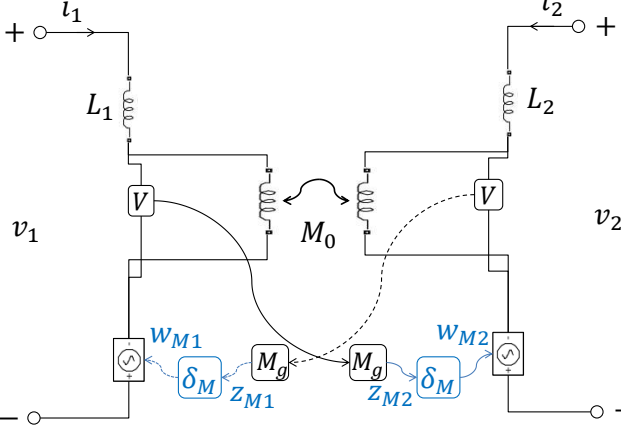
Thus, to automatically derive the matrix of transfer functions M of any uncertain electrical circuit, one must follow the steps below:

- 1) connect the equivalent uncertain elements by their electrical terminals creating the desired circuit topology;
- 2) connect inputs and outputs to the uncertain terminals respecting the ordering (the i^{th} element should have input w_i and output z_i) according to the Δ structure, see Fig. 2;
- 3) connect the desired performance analysis input (voltage or current source) and output (voltage or current measurement), see Fig. 2;
- 4) compute a linear state-space model of M and then the matrix transfer function $M(s)$. This last step can be performed, for example, in Matlab Simulink using the functions `linmod(...)` and `ss(...)`.

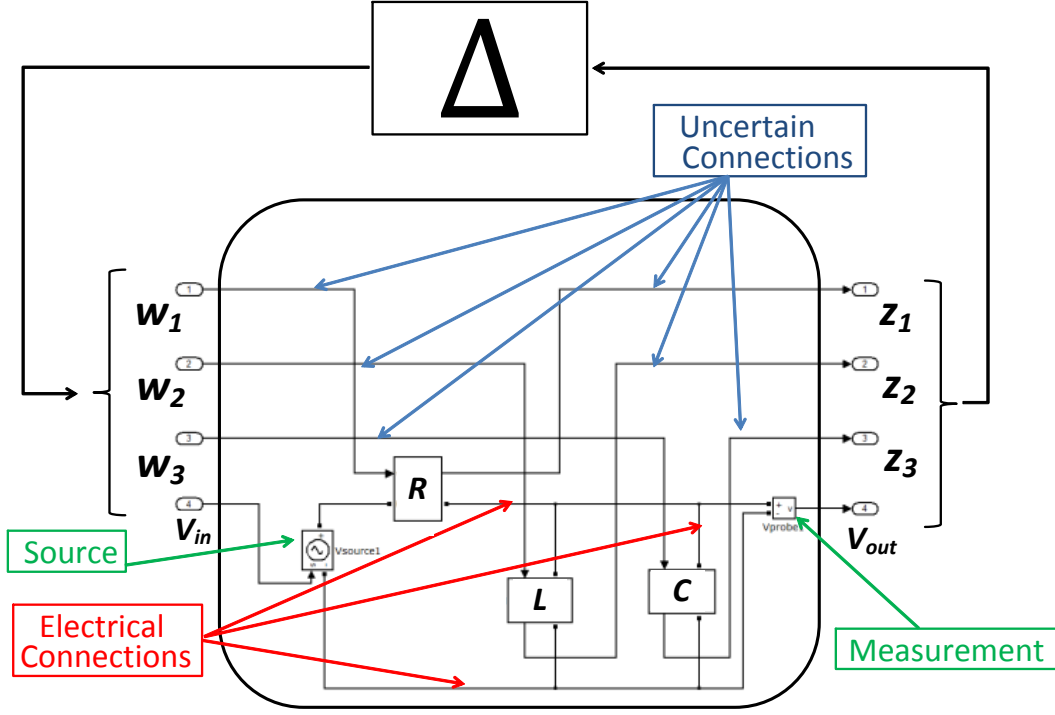

Fig. 2. Systematic extraction of LFT representation.

In this section, the systematic LFT derivation procedure was presented. Performing it together with the optimization problem (10) from section III allows to solve the MIMO WORST-CASE UPPER BOUND PROBLEM. The overall algorithm solving the worst-case tolerance analysis problem of linear electrical circuit *i.e.* upper and lower frequency bound computation, is given in next section.

V. GENERAL ALGORITHM FOR WORST-CASE PERFORMANCE ANALYSIS

As explained in the section III, the lower bound is obtained similarly to the upper bound by inverting the performance transfer function $T_{w_p \rightarrow z_p} = \Delta \star M$ and computing the upper bound of the inverted system $(T_{w_p \rightarrow z_p})^{-1} = (\Delta \star M)^{-1}$:

$$|T_{w_p \rightarrow z_p}(j\omega)|^{-1} \leq \beta^{-1}(\omega) \Leftrightarrow \beta(\omega) \leq |T_{w_p \rightarrow z_p}(j\omega)|$$

To do so, there is no need to recompute a new LFT representation and build a new electrical circuit. The corresponding inverse matrix transfer function M_{inv} can be computed based on the already computed direct matrix transfer function M and thanks to the following LFT inversion relation [21]:

$$M_{inv} = \begin{bmatrix} M_{11} - M_{12}M_{22}^{-1}M_{21} & M_{12}M_{22}^{-1} \\ -M_{22}^{-1}M_{21} & M_{22}^{-1} \end{bmatrix} \quad (14)$$

It should be noted that in the case of a non-invertible systems (zero static gain or non-causal inverse etc.), it is still possible to compute the corresponding inverse M_{inv} but frequency by frequency. In this case, for the frequencies with zero magnitude for nominal transfer function, the lower frequency bounds are zero as well and there is no need to compute the inverse matrix M_{inv} .

The overall algorithm for the worst-case tolerance analysis of linear electrical circuits is now given.

Algorithm 1 Algorithm of the worst-case performance analysis of the linear electrical circuits

- 1) Build the regular nominal electrical circuit model;
 - 2) Derive the LFT representation of this electrical circuit *i.e.* $\Delta \star M$ according to section IV;
 - 3) Determine the matrix of transfer functions M_{inv} corresponding to the inverse LFT, applying (14);
 - 4) Define the frequency grid vector and, for each frequency ω , compute the frequency responses $M(j\omega)$ and $M_{inv}(j\omega)$;
 - 5) Compute the upper bounds (on the exact upper bounds) $\eta(\omega)$ and $\hat{\eta}(\omega)$ solving the optimization problem (10) for $M(j\omega)$ and $M_{inv}(j\omega)$ respectively and for each frequency value;
 - 6) The upper and lower bounds on the frequency response magnitude are $\eta(\omega)$ and $\beta(\omega) = \hat{\eta}^{-1}(\omega)$.
-

VI. APPLICATION

The methodology presented in the previous section will be applied to an EMC filter. Its electrical schematic is shown in Fig. 3. It is a linear electrical circuit model with standard components R, C, L etc.. Since the filter is fabricated in industrial scale, technological dispersions causing parameter variations of these components are inevitable. In this example, there are 12 resistors, 9 inductors and 5 capacitors (including parasitic inductances and capacitances), which corresponds to 26 uncertain parameters. Computing the upper and lower bounds of the filter frequency response magnitude is therefore crucial in order to ensure an acceptable level of filtering performance.

Each electrical component is replaced by its uncertain block diagram and the matrices M and M_{inv} of the filter are readily obtained from the diagram presented in Fig. 4 using `linmod` function of Matlab. As presented in Fig. 4, the structure of the model does not change with respect to the nominal model in Fig. 3, *i.e.* the same number of hierarchical levels, the same interconnection subsystems, *etc.*. The only change concerns the additional uncertain inputs and outputs appearing for each uncertain component model. These inputs/outputs are propagated through every hierarchical level. Only last, global hierarchical level is shown in Fig. 4.

A frequency grid covering typical Conducted EMI standard's for this case was chosen. The computation of upper and lower bounds was then performed thanks to the function available [25]. The final results are presented in Fig. 5. In this figure, the full blue line represents the nominal filter frequency response magnitude. The red lines correspond to the computed upper and lower bounds, while dashed-dot green lines depict the frequency response magnitudes of the filter for the random chosen parameter combinations. For comparison reasons, the classical Monte-Carlo simulations were performed in order to compute the upper and lower frequency bounds as well.

As it can be seen in Fig. 5, no frequency response magnitude of randomly chosen parameter combinations

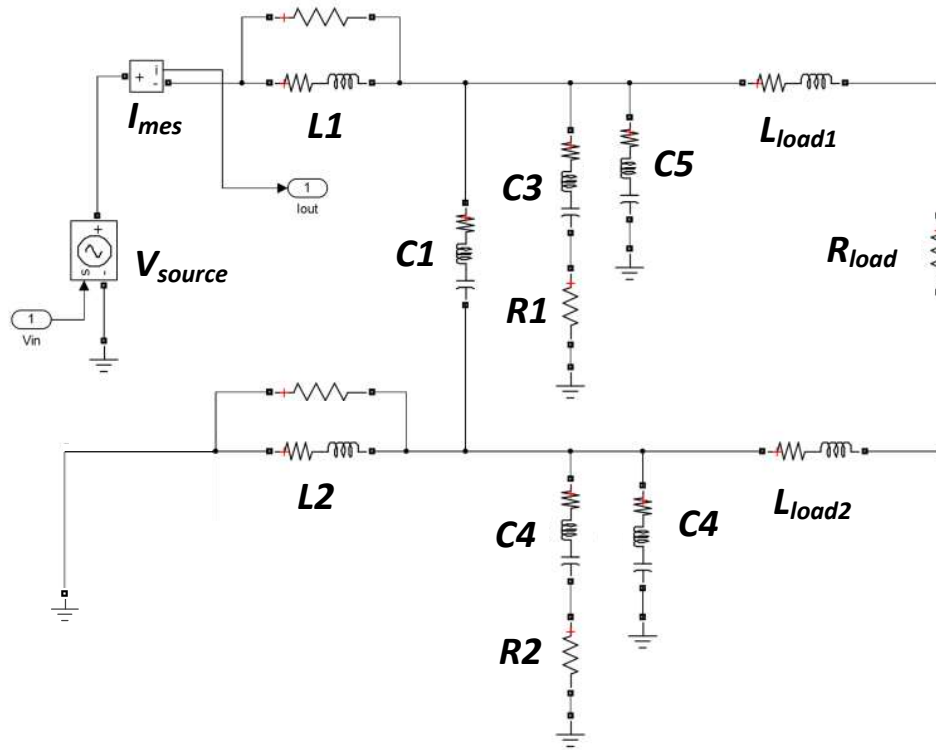

Fig. 3. Electrical schematic of EMC Filter.

(dashed-dot green lines) exceeds the bounds computed by our approach (red lines). Admittedly in contrast to our worst-case analysis approach, where the bounds are ensured, the Monte-Carlo bounds are only underestimation. Despite this, since Monte-Carlo simulations are a reference for robust performance analysis of electrical circuits (as well as for other domains), they should be discussed and compared with our approach. Furthermore, both the Monte-Carlo approach and our approach can be applied for any models of electrical circuit of arbitrary size and hierarchical structure.

First, the corresponding upper and lower bounds are close for both approaches. It is true that the Monte-Carlo bounds are tighter than those of the μ -analysis. There are two reasons which explain the existence of such a gap. The first is, as discussed previously, the possible conservatism of the result. This aspect can be improved by considering new types of parametrization sets $\underline{\Phi}$ for the optimization problem (10), see for example [24]. The second reason is, of course, the fact that the Monte-Carlo bounds are an estimation. This means that there are possible combinations of parameter values that may exceed the computed Monte-Carlo bounds. Ideally, if we could perform

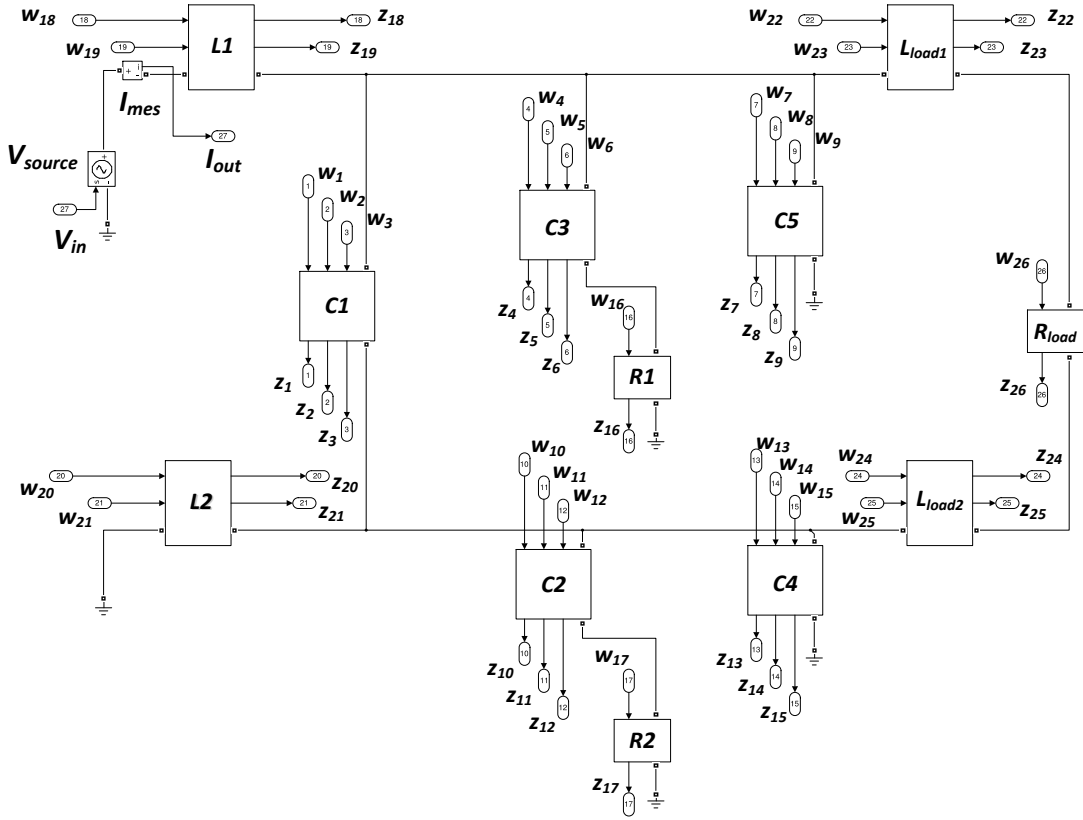

Fig. 4. Systematic LFT derivation of EMC Filter.

an infinite number of Monte-Carlo simulations, the new bounds will be closer to those of the μ -analysis. This is confirmed by comparing Monte-Carlo bounds between 10^4 and 10^5 samples. The case of 10^5 samples ensures a higher probability that the frequency response magnitude is inside of the computed bounds and it can be seen that these bounds approach the μ -analysis upper and lower bounds.

Another comparison aspect is the computational efforts for two approaches. To obtain the bounds for 10^4 samples, the computation time of Monte-Carlo approach is $t_{MC}^4 = 3$ hours and for the case of 10^5 samples $t_{MC}^5 = 28$ hours. Whereas, in order to compute the bounds by μ -analysis approach, ensured for all 100% cases, the computation time obtained is only $t_{\mu} = 17$ minutes. The proposed method is almost 100 times quicker. These time comparisons were carried out on a Intel i7-2860QM Quad-Core 2.5 GHz. Thus, there is ample evidence of advantages of the proposed method when compared to the Monte-Carlo simulations.

VII. CONCLUSION

In this paper, a frequency domain worst-case tolerance analysis method for uncertain linear electrical circuits was presented. The method is based on a robust control theory approach, the so called μ -analysis. To apply the

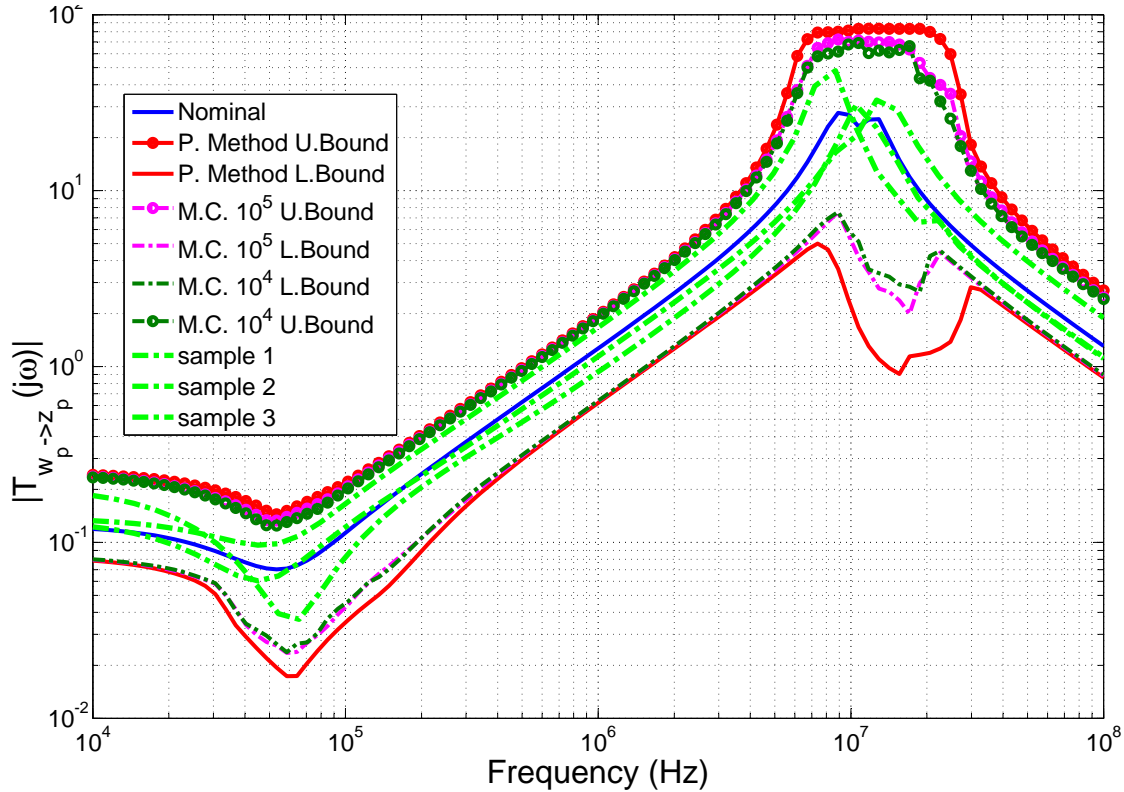

Fig. 5. Bounds computation results for EMC Filter.

μ -analysis, a particular LFT transformation problem must be considered first. The algorithm for systematic LFT derivation and worst-case tolerance analysis of linear electrical circuits was presented. To this purpose, a library of uncertain electrical components was created. The numerical example of EMC Filter proves the efficiency of the proposed approach compared to the classical Monte Carlo methodology.

Future works related to this paper will be an extension of the proposed approach to the case of the worst-case tolerance analysis along ranges of frequency, so that the appropriate choice of frequency grid can be easily performed. Other interesting perspectives are the systematic LFT reduction and the extension to the case of non-linear electrical circuits including switches.

ACKNOWLEDGMENT

This work was supported in part by Agence Nationale de la Recherche, programme VTT 2010, projet E-CEM.

REFERENCES

- [1] S. J. Julier, Jeffrey, and K. Uhlmann, "Unscented filtering and nonlinear estimation," in *Proceedings of the IEEE*, 2004, pp. 401–422.
- [2] L. de Menezes, A. Ajayi, C. Christopoulos, P. Sewell, and G. Borges, "Efficient computation of stochastic electromagnetic problems using unscented transforms," *Science, Measurement Technology, IET*, vol. 2, no. 2, pp. 88–95, march 2008.

- [3] H. Kettani and B. Barmish, "A new monte carlo circuit simulation paradigm with specific results for resistive networks," *Circuits and Systems I: Regular Papers, IEEE Transactions on*, vol. 53, no. 6, pp. 1289–1299, June 2006.
- [4] M. Ferber De Vieira Lessa, C. Vollaie, L. Krähenbühl, and A. Vasconcelos, Joao, "Adaptive unscented transform for uncertainty quantification in EMC large-scale systems," in *Proc. of the 12th International Workshop on Optimization and Inverse Problems in Electromagnetism*, Ghent, Belgium, Sep. 2012, p. CD.
- [5] M. Ferber, C. Vollaie, L. Krahenbuhl, J.-L. Coulomb, and J. A. Vasconcelos, "Conducted EMI of DC–DC converters with parametric uncertainties," *Electromagnetic Compatibility, IEEE Transactions on*, vol. PP, no. 99, pp. 1–8, 2013.
- [6] S. Skelboe, "True worst-case analysis of linear electrical circuits by interval arithmetic," *Circuits and Systems, IEEE Transactions on*, vol. 26, no. 10, pp. 874–879, Oct 1979.
- [7] W. Tian, X.-T. Ling, and R. Liu, "Novel methods for circuit worst-case tolerance analysis," *Circuits and Systems I: Fundamental Theory and Applications, IEEE Transactions on*, vol. 43, no. 4, pp. 272–278, Apr 1996.
- [8] A. Abderrahman, E. Cerny, and B. Kaminska, "Worst case tolerance analysis and clp-based multifrequency test generation for analog circuits," *Computer-Aided Design of Integrated Circuits and Systems, IEEE Transactions on*, vol. 18, no. 3, pp. 332–345, Mar 1999.
- [9] M. Tian and C. J. R. Shi, "Worst case tolerance analysis of linear analog circuits using sensitivity bands," *Circuits and Systems I: Fundamental Theory and Applications, IEEE Transactions on*, vol. 47, no. 8, pp. 1138–1145, Aug 2000.
- [10] N. Femia and G. Spagnuolo, "True worst-case circuit tolerance analysis using genetic algorithms and affine arithmetic," *Circuits and Systems I: Fundamental Theory and Applications, IEEE Transactions on*, vol. 47, no. 9, pp. 1285–1296, Sep 2000.
- [11] J. Leyva-Ramos and J. Morales-Saldana, "Uncertainty models for switch-mode DC-DC converters," *Circuits and Systems I: Fundamental Theory and Applications, IEEE Transactions on*, vol. 47, no. 2, pp. 200–203, Feb 2000.
- [12] L. Kolev, "Worst-case tolerance analysis of linear DC and AC electric circuits," *Circuits and Systems I: Fundamental Theory and Applications, IEEE Transactions on*, vol. 49, no. 12, pp. 1693–1701, Dec 2002.
- [13] R. D. Braatz, P. M. Young, J. C. Doyle, and M. Morari, "Computational complexity of μ calculation," *IEEE Trans. Aut. Control*, vol. AC-39, no. 5, pp. 1000–1002, May 1994.
- [14] J. Doyle, "Analysis of feedback systems with structured uncertainties," *IEE Proc.*, vol. 129-D, no. 6, pp. 242–250, Nov. 1982.
- [15] M. K. H. Fan, A. L. Tits, and J. C. Doyle, "Robustness in the presence of mixed parametric uncertainty and unmodeled dynamics," *IEEE Trans. Aut. Control*, vol. 36, no. 1, pp. 25–38, Jan 1991.
- [16] S. Skogestad and I. Postlethwaite, *Multivariable Feedback Control, Analysis and Design*. John Wiley and Sons Chischester, 2005.
- [17] Y. Nesterov, *Introductory Lectures on Convex Optimization*, ser. Applied optimization. Boston/Dordrecht/London: Kluxer Academic Publishers, 2004, no. 87.
- [18] R. Tymerski, "Worst-case stability analysis of switching regulators using the structured singular value," *Power Electronics, IEEE Transactions on*, vol. 11, no. 5, pp. 723–730, Sep 1996.
- [19] J. Wang, O. Hafiz, and J. Li, "A linear fractional transform (LFT) based model for interconnect parametric uncertainty," in *Design Automation Conference, 2004. Proceedings. 41st*, July 2004, pp. 375–380.
- [20] K. Zhou, J. Doyle, and K. Glover, *Robust and Optimal Control*. Prentice Hall, New Jersey, 1995.
- [21] J. Doyle, A. Packard, and K. Zhou, "Review of LFTs, LMIs, and μ ," in *Decision and Control, 1991., Proceedings of the 30th IEEE Conference on*, Dec 1991, pp. 1227–1232 vol.2.
- [22] S. Font, "Méthodologie pour prendre en compte la robustesse des systèmes asservis: optimisation H_∞ et approche symbolique de la forme standard," Ph.D. dissertation, Université Paris XI Orsay, France, 1995.
- [23] R. A. Horn and C. A. Johnson, *Matrix Analysis*. Cambridge University Press, 1985.
- [24] G. Scorletti, X. Bombois, M. Barenthin, and V. Fromion, "Improved efficient analysis for systems with uncertain parameters," in *IEEE Conf. Decision and Control*, New Orleans, dec. 2007, pp. 5038–5043.
- [25] [Online]. Available: <https://sites.google.com/site/fastwctanalysis/>