



HAL
open science

Electroacoustic absorbers for the low-frequency modal equalization of a room: what is the optimal target impedance for maximum modal damping, depending on the total area of absorbers?

Sami Karkar, Etienne Rivet, Hervé Lissek, David Strobino, Antoine Pittet, Véronique Adam, Alain Roux

► To cite this version:

Sami Karkar, Etienne Rivet, Hervé Lissek, David Strobino, Antoine Pittet, et al.. Electroacoustic absorbers for the low-frequency modal equalization of a room: what is the optimal target impedance for maximum modal damping, depending on the total area of absorbers?. Forum Acusticum 2014, Sep 2014, Krakow, Poland. online proceedings. hal-01065735

HAL Id: hal-01065735

<https://hal.science/hal-01065735>

Submitted on 19 Sep 2014

HAL is a multi-disciplinary open access archive for the deposit and dissemination of scientific research documents, whether they are published or not. The documents may come from teaching and research institutions in France or abroad, or from public or private research centers.

L'archive ouverte pluridisciplinaire **HAL**, est destinée au dépôt et à la diffusion de documents scientifiques de niveau recherche, publiés ou non, émanant des établissements d'enseignement et de recherche français ou étrangers, des laboratoires publics ou privés.

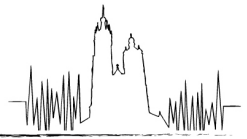

Electroacoustic absorbers for the low-frequency modal equalization of a room: what is the optimal target impedance for maximum modal damping, depending on the total area of absorbers?

Sami Karkar*, Etienne Rivet, Hervé Lissek

Laboratoire d'ÉlectroMagnétisme et d'Acoustique, EPFL, Station 11, Route Cantonale, CH-1015 Lausanne, SWITZERLAND

David Strobino, Antoine Pittet

Laboratoire d'Acoustique Appliquée, HEPIA, rue de la Prairie 4, CH-1202 Geneva, SWITZERLAND

Veronique Adam, Alain Roux

Digital Audio SA, Chemin du Pré Fleuri 3, CH-1228 Plan-Les-Ouates, Geneva, SWITZERLAND

RELEC SA, Rue des Petits-Champs 11a+b, CH-1400 Yverdon-les-Bains, SWITZERLAND

Abstract

Electroacoustic absorbers consist of loudspeakers, shunted with an electrical circuit designed to obtain a given acoustic impedance. Their design and principles are now well understood. Unidimensional experiments, using plane waves under normal incidence in ducts, agree perfectly with simulations and confirm the validity of the model: the low-frequency absorption is maximal (and total) when the acoustic impedance at the diaphragm of the loudspeaker is purely resistive and equals the characteristic impedance of the medium.

However, the working principle of an absorber in a 3D acoustic domain is somehow different: the absorber should bring a maximum of additional damping to each eigenmode, in order to realize a *modal equalization* of the domain. The target acoustic impedance value of the absorber can therefore differ from the characteristic impedance of the medium. Thus, extension of 1D results to the tridimensional case brings up several challenges, such as dealing with non trivial geometry, the finite size of the absorber, as well as the absence of simple formula to determine eigenmodes and their damping in a relatively general framework.

In order to define the optimal target value for the acoustical impedance of an absorber in a realistic case, and to sense how this optimal value depends on some parameters, this paper proposes to address the following cases:

- a 1D case, under normal incidence, where the absorber has a sensibly smaller area than the cross-section of the duct,
- another 1D case, where the absorber is parietal, that is to say, under grazing incidence,
- and a 3D case, where absorbers have a given orientation and position, but a varying area.

PACS no. 43.38.+n, 43.55.+p

1. Introduction

Given the performances of the state-of-the-art audio diffusion system, consumers expectations in terms of fidelity of the electroacoustic system (source, amplifier, loudspeaker, room) are ever-growing. However, when a diffusion system meets the need of a flat frequency response, for both phase and amplitude, the actual performances are modified by the coupling with the room. The characteristic of the

room that deteriorates the performances of a diffusion system is the existence of eigenmodes, that modulate the spatial, frequency as well as transient responses of the system. This effect is particularly significant in the low-frequency range, where conventional passive absorption techniques are ineffective, and where the eigenmodes of the room are well separated, inducing a very heterogeneous transient, frequency and spatial response.

Simple parametric equalization techniques can locally compensate for the room response, but only in a very localized area around a sweet spot (or several sweet spots), while the performances are actually deteriorated in other

* corresponding author: sami.karkar@epfl.ch

places of the room. A global approach would need, on the other hand, to modify directly the eigenmodes of the room.

The concept of acoustic absorbers based on shunted loudspeakers has been proposed and developed by [1, 2, 3] as a solution to this problem. First developed in 1D waveguides, using plane wave under normal incidence, the technique consists in matching the impedance at the diaphragm of the loudspeaker to the characteristic impedance of the waveguide, canceling out the reflexion coefficient of the termination, which then realize a perfectly absorptive boundary condition on a rather wide frequency band centered on the loudspeaker mechanical resonance frequency. In a 1D resonator, if one of the termination is replaced by this device, the eigenmodes located in that frequency band are infinitely damped and disappear. If a source is located inside this resonator, the sound field is not annihilated, but the resonances due to the reflexions on both ends disappear and the frequency response of this “1D listening room” is flattened.

Extension of these results to the tridimensional case, is still a matter of research. Additional degrees of freedom such as the position and orientation of absorbers in the room, the minimum area of absorbers needed, or the target acoustic impedance, are so many parameters that influence the equalization performance in real conditions.

The aim of this paper is to study the concurrent influences of two of these parameters on the performance of the absorbers, namely the total area of absorbers placed in the room and the target acoustic impedance. In the next section, we carry a numerical study on the classical 1D resonator fitted with an electroacoustic absorber at one end, but with a non uniform boundary condition: the absorber area is much smaller than the cross section of the waveguide. In the following section, we investigate the same 1D resonator, but with the absorber placed along the wall of the duct (grazing incidence), near one end. Finally, guided by the previous results, we investigate the case of a realistic 3D listening room.

2. 1D waveguide with absorber under normal incidence

In what follows, we shall consider air, approximated as a lossless medium, as the medium of propagation. Physical parameters take the following values: the air speed is $c=346.0\text{m/s}$ and the density is $\rho=1.185\text{kg/m}^3$. The characteristic impedance is $Z_c=\rho c=410.0\text{Pa.s/m}$.

2.1. Ideal case: $S_{abs}=S$

In the most general case, when an incident plane wave is directed toward an absorber, the pressure amplitude reflexion coefficient of the plane wave is given by:

$$r = (Z_{abs} \cos \theta - Z_c) / (Z_{abs} \cos \theta + Z_c) \quad (1)$$

where θ is the incidence angle, and $Z_{abs}=p/v$ is the specific acoustic impedance at the membrane of the absorber.

We also introduce the specific impedance ratio of the absorber: $\zeta=Z_{abs}/\rho c$.

The energy absorption coefficient is deduced from the reflexion coefficient as:

$$\alpha = 1 - |r|^2 \quad (2)$$

When the absorber is normal to the plane wave ($\theta = 0$), the reflexion coefficient becomes: $r = (Z_{abs} - Z_c) / (Z_{abs} + Z_c)$. Then, perfect absorption ($\alpha=1$) is achieved for $Z_{abs}=\rho c$, or $\zeta=1$.

In the case of a duct of cross-section area S and length L , fitted at one end with a perfectly rigid termination and an absorber of the same cross-section shape and area $S_{abs}=S$ at the other end, the complex eigenfrequencies ω_n are the critical values of the input impedance computed at the rigid end:

$$Z_{in}(\omega) = \frac{\zeta + j \tan(\omega L/c)}{1 + j \zeta \tan(\omega L/c)} = j \tan(kL + \eta) \quad (3)$$

where $j^2 = -1$, $k = \omega/c$ is the wavenumber, and η is defined such that $j \tan(\eta)=\zeta$.

The eigenfrequencies ω_n are then:

$$\omega_n = (2n - 1)\pi \frac{c}{2L} - \eta \frac{c}{L} \quad (4)$$

In the case where Z_{abs} is purely resistive, ζ is real, then η is purely imaginary and defines the imaginary part of the eigenfrequency, which represents the damping of the corresponding eigenmode: the greater the imaginary part of the eigenfrequency, the greater the damping, and the quicker the decay of free oscillations corresponding to that mode. Note that a rigid boundary is equivalent to $\eta = \pi/2$ and the above formula gives the classical (multiples of) half-wavelength series of a closed-closed pipe: $f_n = n \frac{c}{2L}$. On the other hand, a free boundary is equivalent to $\eta = 0$ and one recovers the (odd multiples of) quarter-wavelength series of an open-closed pipe: $f_n = (2n - 1) \frac{c}{4L}$.

2.2. Non uniform boundary conditions: $S_{abs} \neq S$

If the absorber cross-section area S_{abs} is smaller than that of the duct S , and is surrounded by a hard wall (see figure 1, left end of the duct), then the boundary condition on this end is non uniform. Locally, near this termination, the field is not uniform anymore.

When $S_{abs}/S \simeq 1$, the hypothesis that the pressure p is almost uniform seems reasonable. The velocity field v , however, is equal to the velocity of the absorber v_{abs} on the membrane, but must be equal to zero on the surrounding wall. By conservation of the volume flow, this termination has an approximate effective impedance $Z_{eff}=\frac{S}{S_{abs}}Z_{abs}$, which differs from the preceding by a factor corresponding to the ratio of the absorber area to the duct cross-section area.

On the other hand, if the absorber area is substantially smaller than the cross-section of the wave-guide, the approximation does not hold and an analytical approach shall

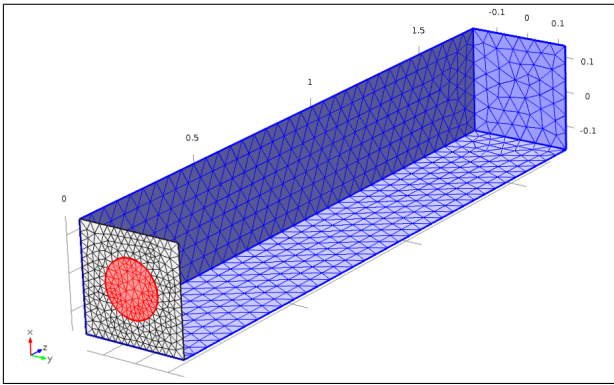

Figure 1: Typical geometry and mesh of the FE model for the 1D resonator with absorber at one end, under normal incidence.

require to decompose the field on the transverse modes, as proposed by [4].

This semi-analytical approach still requires numerical computations to approximate some integrals, and finally leads to a complex nonlinear problem of size $n \gg 1$, due to the contribution of numerous transverse modes to solve for the sharp boundary between the absorber membrane and the surrounding hard wall. Thus, we decided to determine the longitudinal eigenmodes and corresponding eigenfrequencies of this resonator with a practical approach, that would be more easily generalized to different geometries: a Finite Element Method commercial code.

2.3. FE model results

In this section, the results obtained with the COMSOL Multiphysics [5] commercial FE analysis software are reviewed.

Figure 1 illustrates the configuration under study, as well as a typical mesh for a given size of the absorber. The duct has a square cross-section, whose width is $a=30\text{cm}$ and length is $L=1.7\text{m}$, which should result in eigenfrequencies around $n \times 100\text{Hz}$ in a closed-closed pipe. The absorber is figured with a disk (colored in red on the figure) centered on the termination and on which a purely resistive and frequency-independent impedance is enforced. The case depicted on fig. 1 corresponds to an absorber having a radius $r_{abs}=8\text{cm}$. Every configuration (for different absorber sizes) is meshed with quadratic elements having a minimal size of 5mm and maximal size of 5cm. The typical configuration depicted here results in a mesh of 20130 elements.

The absorber radius varies from 1 to 10cm, and the specific impedance ratio on the disk varies from 10 (almost a rigid boundary condition) to 0.1 (almost a free boundary condition). For each configuration, the eigenmodes were computed. Results for the three first modes are shown on figure 2: the modal decay time MT_{60} (in s)¹ is plotted as

¹ It is the modal equivalent to the reverberation time RT_{60} . It is related to the imaginary part of the eigenfrequency as: $MT_{60}=3\log(10)/(2\pi\text{Im}(f_n))$.

color map, function of ζ and the ratio S_{abs}/S_{tot} , where $S_{tot}=2S$ is the total area of the “walls”². Contour lines correspond to the values 0.05s, 0.1s, 0.2s, 0.5s, 1s, 2s, and 5s.

In the bottom-left corner of these color maps, the almost reflective case leads to modal decay times of about 10s. In the upper part of the maps, the MT_{60} forms a “valley”: for absorbers of sufficient size, there exists an optimal value of the target impedance that will result in a maximized modal damping. This zone corresponds to an absorber covering $\approx 10\%$ of the walls.

Considering the region neighboring $\zeta=1$, the absorbers must cover 1,5% of the walls in order to obtain an modal decay time around 1s. Let us extrapolate and make a rough estimate: a 15cm radius speaker (12" diameter) have a typical equivalent piston surface area of 500cm^2 , while a typical small room that would be 3m high and 4m long, would have 24m^2 of walls across the main dimension. Approximately 8 absorbers based on these loudspeakers, placed along the walls and oriented perpendicular to the main dimension, would be necessary to bring the modal decay time of the (1,0,0), (2,0,0) and (3,0,0) modes down to a second, with a specific impedance close to ρc . Moreover, if the modes relative to the other two dimensions are not affected by these absorbers, more of them would be needed (oriented differently) to damp these modes.

Now, if one could design absorbers with a specific impedance of $\rho c/2$, the number decreases to 4 absorbers instead of 8. If the specific impedance goes down to $\rho c/4$, this number decreases to 2 or 3 absorbers. The total number of absorbers needed will then essentially depend on how these absorbers, designed, placed, and oriented to damp modes in the main direction, can interact with modes in the transverse directions (grazing incidence) and if they can provide damping for these modes too.

For this reason, we will now turn to the case of a grazing incidence.

3. 1D waveguide with absorber under grazing incidence

Starting from the previous model, we move the absorber disk to the side, near the termination position. Figure 3 illustrates this new configuration, where both end now have perfectly rigid walls. Meshing and parameters are the same as in the previous case. Results for the first three modes are shown on figure 4, where the MT_{60} (in s) is plotted as a colormap, function of ζ and the ratio S_{abs}/S_{tot} of absorbing area to total reflecting walls area.

Unlike what was anticipated, the absorber does actually damp the first modes. Its effect on the first two modes is almost the same as in the previous case. There is only a little weaker effect on the third mode. The effectiveness of the parietal absorber is quite unexpected. It can be understood by looking at the wave fronts: Figure 5 illustrates

² Here, the said “walls” are only those participating to the resonance, that is to say the terminations, which are perpendicular to the wave vector. Side walls of the duct are not considered.

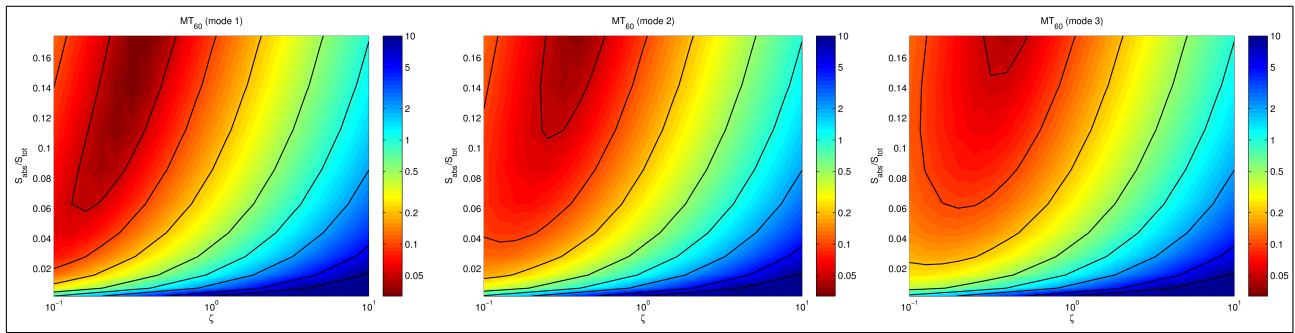

Figure 2: Absorber under normal incidence, in a 1D waveguide : MT_{60} (in s, log scale) of the first three eigenmodes, as a function of the ratio of absorbing surface to reflective surface and of the absorber impedance ratio. Contour levels : .05, .1, .2, .5, 1, 2, 5, and 10s.

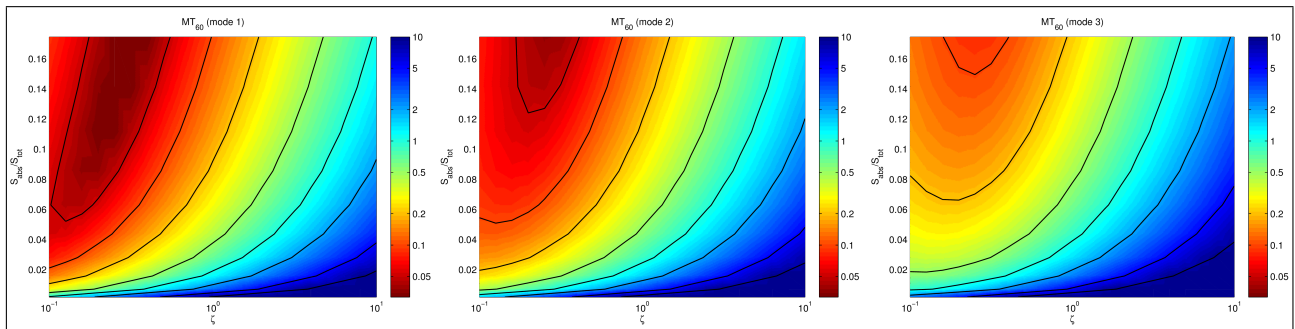

Figure 4: Absorber under grazing incidence, in a 1D waveguide : MT_{60} (in s, log scale) of the first three eigenmodes, as a function of the ratio of absorbing surface to reflective surface and of the absorber impedance ratio. Contour levels : .05, .1, .2, .5, 1, 2, 5, and 10s.

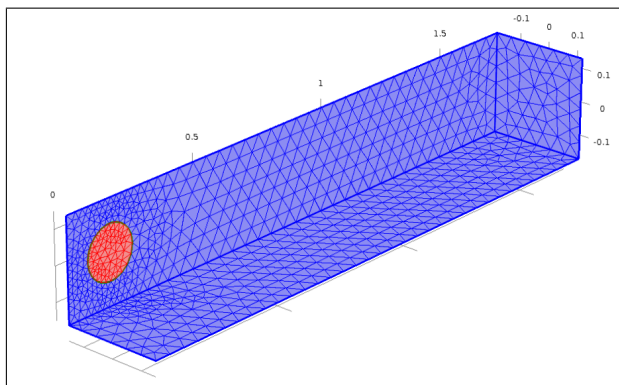

Figure 3: Typical geometry and mesh of the FE model for the 1D resonator with absorber near one end, under grazing incidence.

iso- p surfaces of the first mode (rear view), in the case of a rather large absorber ($r_{abs}=8\text{cm}$, $S_{abs}/S_{tot}=11\%$) with a moderate impedance ($\zeta=1$). It can be seen that the wave fronts are locally perturbed by the presence of the absorber and bend toward its surface. Thus, the wave vector is locally almost normal to the absorber surface, instead of the expected grazing incidence.

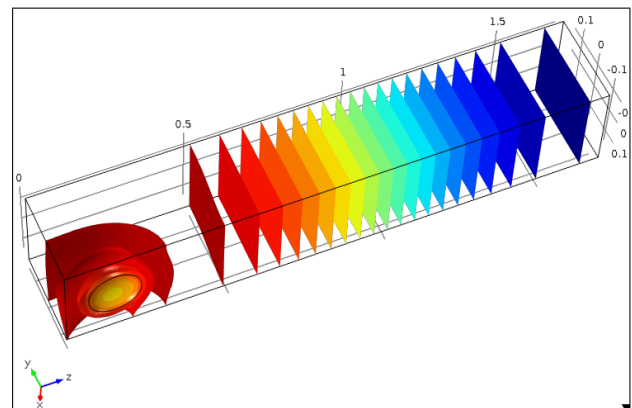

Figure 5: Pressure isosurfaces for the first mode of the 1D waveguide with parietal absorber (rear view). Absorber radius: $r_{abs}=8\text{cm}$, absorber area ratio: $S_{abs}/S_{tot}=11\%$, specific impedance ratio: $\zeta=1$.

These very encouraging results suggest that the absorber orientation would have little influence on the absorption of a mode with a given spatial structure, as long as it remains sufficiently close to a maximum of pressure level of this mode.

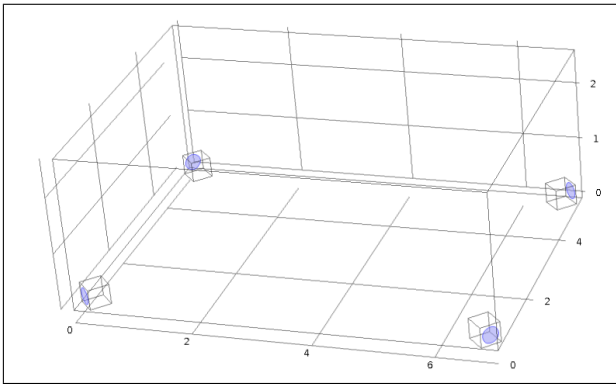

Figure 6: Simulation of a real 3D room with four electroacoustic absorbers. Each absorber, in its individual closed box, is placed on the floor near a corner, in a vertical plan oriented 45° from the walls.

In the next section, we propose to simulate the situation in a 3D room in order to study how these results extend to a more realistic case.

4. 3D case study : a medium-size room

A room having dimensions close to real listening rooms has been simulated. The simulated room is a 5.10m large, 7.02m long, 2.70m high parallelepiped. Hard boundary conditions are imposed on all wall surfaces other than the absorbers. This hypothesis is indeed not valid above 200-300Hz, but the present study aims at covering the 20-100Hz range, where the frequency response of the room is clearly modal and modes do not overlap much.

Four absorbers, each in an individual closed box, are placed in the four lower corners of the room, as illustrated on figure 6. Their diaphragm (blue color on the figure) is vertical and faces the corner at 45° from each wall, as previous studies [3] suggested this position would optimize their efficiency. The frequency dependence of the absorbers has been idealized: a constant, purely resistive acoustic impedance is prescribed at the diaphragm of the absorbers. The impedance ratio ζ of the absorbers varies in the study between 0.1 and 10. The absorbers radius varies between 8cm and 17cm. Meshing and computation conditions are the same as in the previous sections, though leading to much higher number of elements, and longer computation times.

It would be tedious to examine every eigenmode up to 100Hz, however we selected a few of them in order to illustrate the results. On figure 7, nine different MT_{60} maps are plotted, each representing one eigenmode. Each map represents the value of the MT_{60} (in seconds) of the mode, as a function of ζ and r_{abs} .

The first row shows MT_{60} maps of low order modes, namely (1,0,0), (1,1,0) and (1,1,1) respectively, for which the absorbers are rather efficient: the modal decay times come down to 1.5s. The second row corresponds to somewhat higher order modes, that are still well damped by the

absorbers. The third row illustrate some modes that are little affected by the presence of the absorbers, despite their relatively low order. This last feature is unexpected, but could be due to the fact that the absorbers seem very inefficient to damp the vertical mode (0,0,1) (not shown here).

The absorbers seem to be particularly efficient on the (1,1,0) mode, which happens to have a wave vector that is normal to the absorber diaphragms: the lower right corner of the map shows a MT_{60} around 5s, while in the optimal configuration it comes down to 1s.

In the present case, the larger the absorbers, the better the result. This is probably due to the fact that the total absorbing area is relatively small compared to the total reflecting area of the room. For the largest absorbers, however, the optimal value of ζ is not identical to all modes. As each mode has its own central frequency, an optimal absorber would have a frequency-dependent resistance that matches these different values.

5. Conclusion

In this communication, the effect of electroacoustic absorbers on the damping of a cavity eigenmodes was investigated. The absorbers were simulated as flat disks presenting a constant, purely resistive acoustic impedance. Two numerical studies on unidimensional cavities have shown that stationary waves are affected by an absorber, whether it is oriented normal to the propagation dimension (terminal position), or parallel to it (parietal position), though favoring slightly the first case for higher order modes.

A third numerical study on a 3D cavity, representative of a real listening room for the low frequency domain, showed the efficiency of the electroacoustic absorbers to provide additional damping to the low frequency eigenmodes of the room, thus realizing modal equalization. Results further show that the optimal acoustic impedance value of the absorbers (the target acoustical impedance) depends on the mode, and on the total area of absorbers.

Further work should include the frequency dependence of the acoustic impedance of the absorbers: the reactive term is dominant at very low and very high frequencies. Moreover, the absorption bandwidth is also dependent on the target acoustical resistance: the lower the target, the smaller the bandwidth. Accounting for all these effects in the simulation could help finding the trade-off between bandwidth and target acoustical impedance that maximizes the efficiency in terms of modal equalization.

Besides, a more realistic model of the listening room, taking into account the absorption properties of current materials present in the room would allow us to compare simulation results with experimental results, thus giving a better figure of the effects of the absorbers on a real listening room.

Last, a global optimization criteria, such as the total amount of energy absorbed in a given room for a given typical excitation, together with a typical frequency weighting function in relation with perception (A- or C-weighting, for instance), is still to be defined in order to be able to

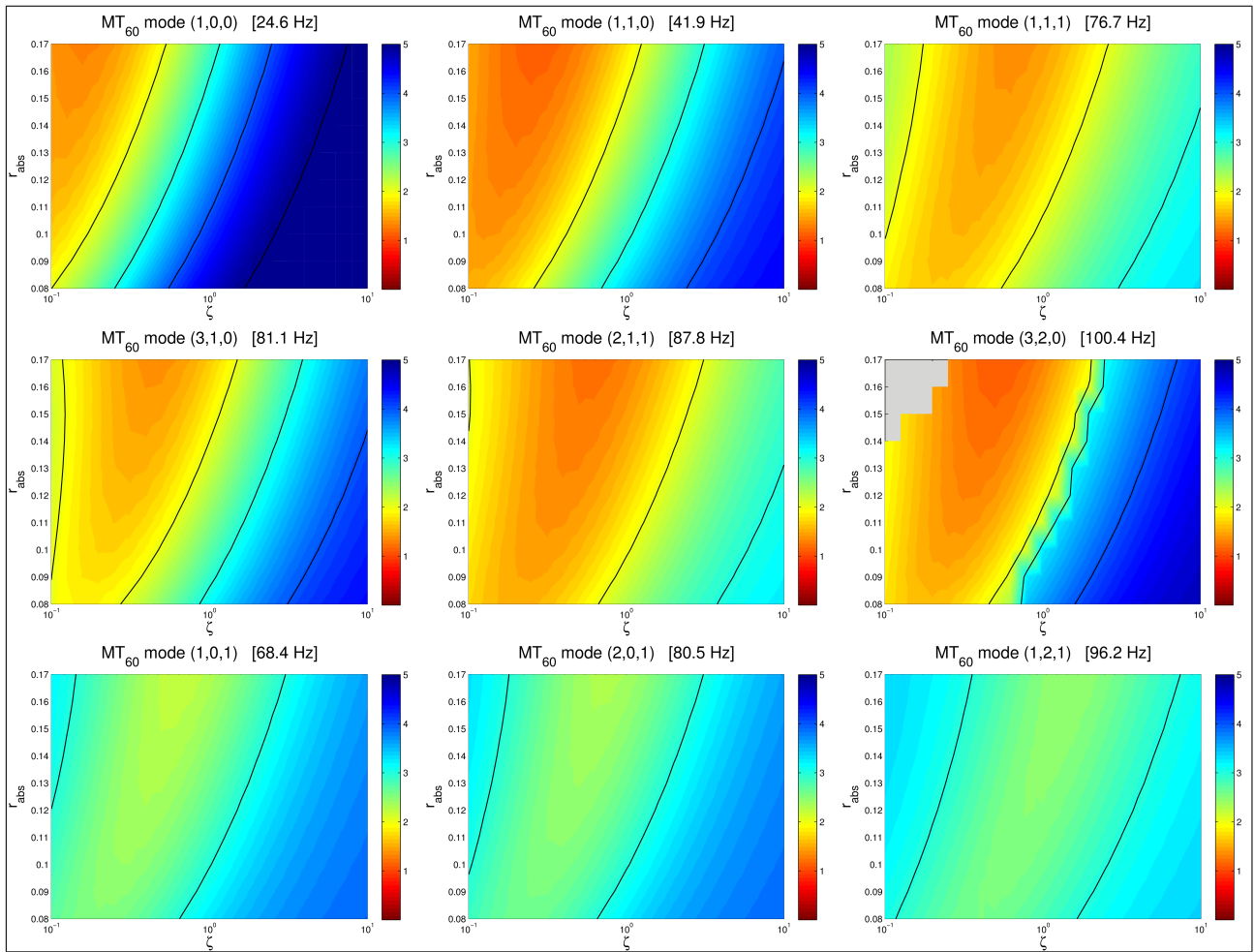

Figure 7: MT_{60} maps (color, linear scale in s) of nine selected eigenmodes of a 3D room with four absorbers, function of the absorber size r_{abs} (in m) and their impedance ratio ζ . Contour levels : 1, 2, 3, 4, and 5s.

find the best setup in terms of perceived effect. *In fine*, a perceptual evaluation study on a real test case shall eventually validate the results and the associated devices. Such psychoacoustic study will be carried out once the most favorable configurations have been found resorting to a combination of simulations and experiments.

Acknowledgement

This work has been supported by the Swiss Commission for Technology and Innovation (CTI), under the project INTERACTS, agreement num. 14220.1 PFNM-NM.

References

- [1] H. Lissek, R. Boulandet, and P.-J. René. Shunt loudspeakers for modal control of rooms. In *Proc. 16th International Congress on Sound and Vibration*, 2009.
- [2] H. Lissek, R. Boulandet, and R. Fleury. Electroacoustic absorbers: bridging the gap between shunt loudspeaker and active sound absorption. *J. Acoust. Soc. Am.*, 129(5), 2011.
- [3] E. Rivet and H. Lissek. Optimization of electroacoustic resonators for semi-active room equalization in the low-frequency range. In *International Congress of Acoustics 2013*, Montreal, Canada, 2013.

- [4] V. Pagneux, N. Amir, and J. Kergomard. A study of wave propagation in varying cross-section waveguides by modal decomposition. part i. theory and validation. *J. Acoust. Soc. Am.*, 100(4), 1996.

- [5] COMSOL Inc. Comsol Multiphysics ® ©, version 4.3a, 2012.