



HAL
open science

A laser ranging method dedicated to path lengths equalization in diluted telescopes

Michel Lintz, Clément Courde

► **To cite this version:**

Michel Lintz, Clément Courde. A laser ranging method dedicated to path lengths equalization in diluted telescopes. OHP2013 Colloquium: Improving the performances of current optical interferometers & future designs, Sep 2013, Saint Michel L'Observatoire, France. pp.73-77. hal-01058888

HAL Id: hal-01058888

<https://hal.science/hal-01058888>

Submitted on 15 Sep 2014

HAL is a multi-disciplinary open access archive for the deposit and dissemination of scientific research documents, whether they are published or not. The documents may come from teaching and research institutions in France or abroad, or from public or private research centers.

L'archive ouverte pluridisciplinaire **HAL**, est destinée au dépôt et à la diffusion de documents scientifiques de niveau recherche, publiés ou non, émanant des établissements d'enseignement et de recherche français ou étrangers, des laboratoires publics ou privés.

A laser ranging method dedicated to path lengths equalization in diluted telescopes

M. Lintz¹, C. Courde²

¹*ARTEMIS, Univ. de Nice, Observatoire de la Côte d'Azur & CNRS, Bd de l'Observatoire, 06304 Nice, France (corresp. author michel.lintz@oca.eu)*

²*Univ. Nice Sophia Antipolis, CNRS, IRD, Observatoire de la Côte d'Azur, Géoazur UMR 7329, 250 rue Albert Einstein - 06560 Valbonne - France*

Abstract. When implementing a diluted telescope with large dimensions, one has to reach the equal path condition to the different segments of the primary mirror. In this work we suggest a way to implement a fast laser ranging method able to provide the error signal, using phase detection of the microwave modulation of a laser beam.

1. Introduction

Beyond classical observation instruments such as telescopes, interferometry takes advantage of the wave nature of light to provide increased angular resolution by combining light beams from optics placed at different locations on a large basis. Interferometric operation is obtained when the different optical paths are equal to within one or a few optical wavelengths. Although the requirement of path equalization can be clearly stated, it can be more difficult to implement, as the paths to equalize are the ones that come from the star or the object to be observed. The situation is somewhat more tractable when one has to set an ensemble of mirrors so as to form a large “diluted” spherical mirror: the sphere geometry can be realized by equalizing the paths from each of the segments to the curvature center of the expected sphere. Alternately, one can use an optics at curvature center (Fig. 1), in a way inspired from Le Coroller et al. (2012). This work addresses the problem of designing a laser ranging scheme that provides a signal proportional to the path difference between two adjacent segments. Two requirements can be stated: i) The measurement of the path length difference should be obtained, with a micron-scale resolution in a time shorter than the typical time scale of atmospheric turbulence, that is, in less than a millisecond. ii) The zero of this measurement should be free of errors to within 1 μm .

We suggest a measurement scheme that uses an optical beam modulated at high frequency, which is addressed to the first, then the second segment, before the length difference is extracted. Switching from the first to the second mirror can be done in much less than a millisecond.

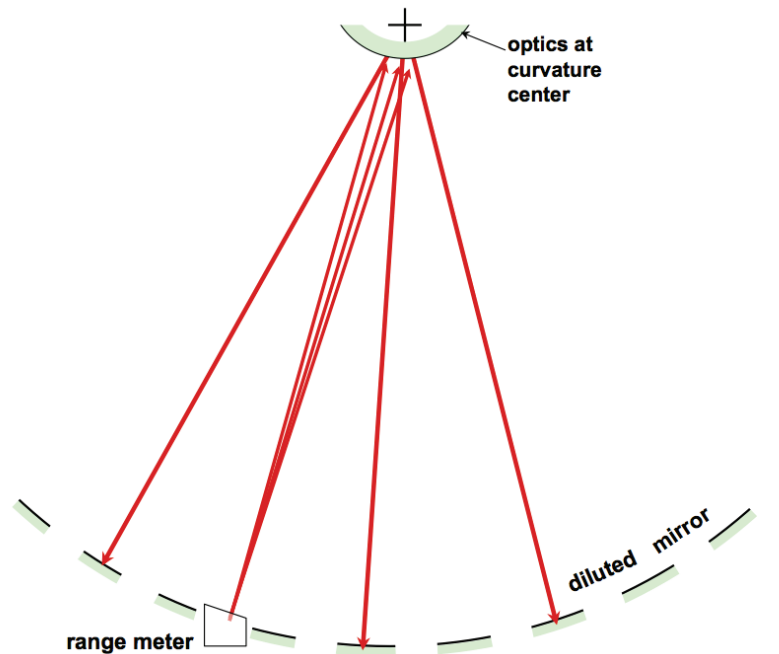

Figure 1.: *Use of laser ranging for optical path equalization via the curvature center.*

2. Measurement principles

In the absolute measurement of long distances, one of the most successful ranging schemes is derived from the idea put forward by H. Fizeau (1849). In present day commercial “absolute distance meters”, Fizeau’s double-pass cogwheel is replaced by a double-pass modulation of the polarization at a frequency around 2GHz. Measuring the modulation frequency for which the double-pass transmitted light is at a minimum prevents from detecting the phase of the return modulation.

The method that uses the phase measurement of a modulated light beam has been known for a long time (Bender 1967), but has not been used in commercial instruments, due to its well-known systematic errors such as electrical or optical crosstalk, or amplitude-to-phase coupling. When it comes to reaching precisions of about $1 \mu\text{m}$, even at frequencies in the range of 10 to 20 GHz, these errors become very large and difficult to reject, as a precision of $1 \mu\text{m}$ over the distance corresponds to a precision of 10^{-4} cycle of the phase measurement at 15 GHz.

It has been shown that the errors associated to the electrical cross-talk and amplitude-to-phase (AM-to-PM) coupling can be rejected to a large extent by implementing a reference and a measurement arm, and operating at a microwave frequency such that the reference and measurement optical signal are in phase (Courde, Brillet & Lintz 2009). Rejection is obtained if some kind of switch allows to exchange the two optical signals with respect to the detectors: the systematic errors are unchanged in the reversal (while the propagation phase is reversed), and are eliminated by lock-in detection. This measurement scheme has proved

capable of a ≈ 10 nm resolution on a 10-100 s integration time scale (Courde, Brillet & Lintz 2010).

In the problem of equalizing the distances towards two segments of a diluted mirror, the requirement of measuring a distance with a high accuracy is absent. One needs a signal proportional to the length difference, with well-defined zero. But the requirements for an *absolute* distance measurement are relaxed. For that reason one can devise a measurement set-up that compares the phase of the opto-microwave signal from the two segments. The comparison can be made at short time scale, using polarization control. By switching the polarisation from one to the other linear polarizations, one can address two different directions, hence two different segments of the primary, diluted mirror, using the propagation in a birefringent material.

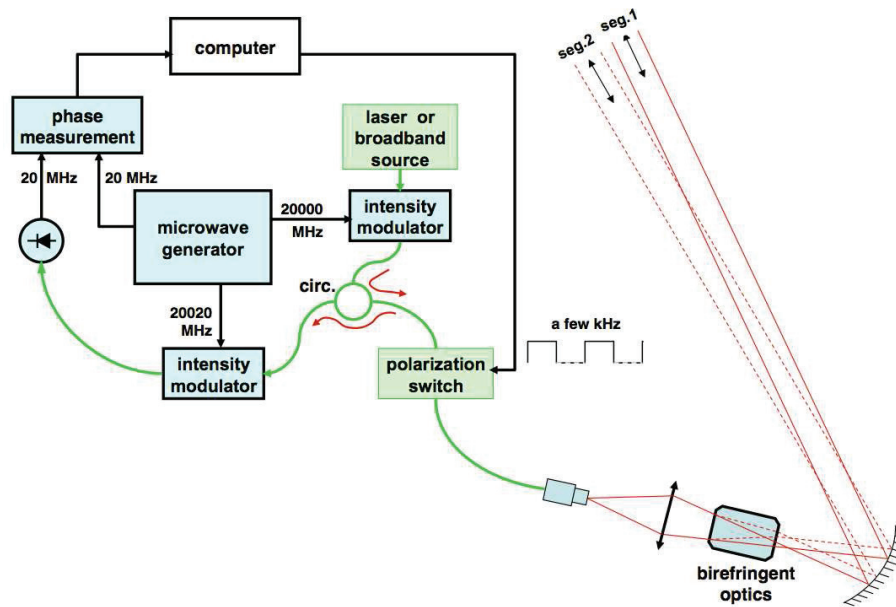

Figure 2.: Principle setup of a path-difference range-meter with polarization addressing. Green lines: optical fibers. Red lines: laser beams. Black lines: electrical signals. Circ.: fibered optical circulator. The 20 MHz signal is phase-locked to the 20020 MHz - 20000 MHz frequency difference.

Various kinds of polarization switch are compatible with the $\ll 1$ ms switch time requirement: fibered devices, either electro-optical, magneto-optical or elasto-optical, or free space Pockels cells.

3. Systematic errors and noise

Optical cross-talk (such as imperfect polarization extinction) can give rise to potentially large systematic effects. It affects the return polarization by $2\sqrt{\gamma} \cos[2\pi\Delta L/\lambda_{opt}]$ where γ is the cross-talk between the two beams and ΔL

the path length difference. It can affect the measured phase if it couples to polarisation defects in the optics that bring the return beam to the photodiode. This contribution can bring large instability to the measured phase, as soon as $\Delta L/\lambda_{opt}$ varies. However it has been shown (Courde et al. 2010) that at equal path length ($\Delta L \ll \Lambda$) this phase error cancels: the interference contribution only affects the amplitude of the signal. If AM-to-PM coupling is adequately dealt with (see below) the interference due to cross talk should have negligible contribution to the phase measurements. The use of a broadband source, rather than a laser source, is another way to reject the consequence of interference due to cross-talk (Courde et al. 2010), or due to a stray beam, whatever its origin, when the stray beam path length difference is larger than the coherence length of the light used for the ranging measurement.

While for Courde et al. (2009, 2010) the modulation frequency is locked to the value that gives equal phase value in the two states of the measurement, here modulation frequency is essentially a free parameter. One can take advantage of this by tuning the frequency to the value for which the electrical cross talk gives no contribution to the phase difference. Once an appropriate value has been obtained, it has no reason to drift, if the setup is not modified.

AM-to-PM coupling has been studied by Phung et al. (2014, this workshop). The most efficient way to remove the AM-to-PM coupling, including the one that results from thermal transients in the photodetector consists in demodulating the microwave optical signal. The phase shifts (at the intermediate frequency, 20 MHz) are then reduced by a factor of $20 \text{ GHz} / 20 \text{ MHz} = 1000$ and negligible compared to the target accuracy of 10^{-4} cycle.

Finally (see Phung 2013, Fig. 6-7 therein), the phase measurement of a 20 GHz modulation has been repeatedly obtained with a noise below 10^{-4} cycle for durations of 100 μs . This corresponds to better than $10^{-4}\Lambda = 10^{-4} \times 15 \text{ mm}$ on the round-trip path length. Thus, the distance to a given segment should be measurable to better than 0.8 μm , in laboratory conditions, in less than a millisecond.

4. Conclusion

The method outlined in this work allows to implement a path length difference measurement adapted to the necessary equalization of the piston of the different segments of a diluted telescope. The laser ranging measurement is obtained by microwave modulation and demodulation of a laser source (or broadband source). Polarization control allows to switch in much less than a millisecond from one segment to the next, a time scale that prevents turbulence or drifts in the microwave instrumentation from adding noise or drifts in the measurement.

References

- Bender, P. L. 1967, Proceedings IEEE 55, 1039
 Courde, C., Brillet, A., Lintz, M. 2009, Measurement Science and Technology 20, 127002
 Courde, C., Brillet, A., Lintz, M. 2010, Instrumentation Mesure Métrologie 10, 81 (in french)

- Fizeau, H. 1849, Comptes Rendus T29, 90,
http://www.academie-sciences.fr/activite/archive/dossiers/Fizeau/Fizeau_pdf/Fizeau_pli878.pdf,
http://www.academie-sciences.fr/activite/archive/dossiers/Fizeau/Fizeau_pdf/CR1849_p90.pdf
- Le Coroller, H. et al. 2012, A&A 539, A59
- Phung, D.-H. 2013, Thèse de doctorat de l'Université de Nice,
<http://tel.archives-ouvertes.fr/docs/00/86/80/28/PDF/2013NICE4038.pdf>
- Phung, D. H., et al. 2014, in Improving the performances of current optical interferometers & future designs, colloquium held in OHP, France, September 23-27, 2013, edited by L. Arnold, H. Le Coroller & J. Surdej