



**HAL**  
open science

# Induction Motors Direct Field Oriented Control with Robust On-Line Tuning of Rotor Resistance

Mohamed-Saïd Naït-Saïd, Mohamed Benbouzid

► **To cite this version:**

Mohamed-Saïd Naït-Saïd, Mohamed Benbouzid. Induction Motors Direct Field Oriented Control with Robust On-Line Tuning of Rotor Resistance. IEEE Transactions on Energy Conversion, 1999, 14 (4), pp.1038-1042. hal-01052372

**HAL Id: hal-01052372**

**<https://hal.science/hal-01052372v1>**

Submitted on 25 Jul 2014

**HAL** is a multi-disciplinary open access archive for the deposit and dissemination of scientific research documents, whether they are published or not. The documents may come from teaching and research institutions in France or abroad, or from public or private research centers.

L'archive ouverte pluridisciplinaire **HAL**, est destinée au dépôt et à la diffusion de documents scientifiques de niveau recherche, publiés ou non, émanant des établissements d'enseignement et de recherche français ou étrangers, des laboratoires publics ou privés.

# Induction Motors Direct Field Oriented Control with Robust On-Line Tuning of Rotor Resistance

M.S. Naït Saïd\*

M.E.H. Benbouzid  
Senior Member, IEEE

University of Picardie “Jules Verne”  
7, Rue du Moulin Neuf - 80000 Amiens, France  
\*On leave from the University of Batna (Algeria)

**Abstract:** This paper proposes an alternative rotor resistance identification method used in the frame of a Direct Field Oriented Control (DFOC) of induction motors. The authors are investigating the use of the induction motor instantaneous reactive power for rotor resistance identification on the basis of the Model Reference Adaptive System (MRAS) method. In fact, from a practical point of view, the instantaneous reactive power can give quite sufficient real time information on the induction motor behavior. The proposed identification method can be achieved with on-line tuning of the inverse rotor time constant with robustness against stator resistance variation. Computer simulations are given to highlight the feasibility, the simplicity, and the robustness of the proposed method.

**Keywords:** Induction motor, Direct Field Oriented Control (DFOC), rotor resistance identification, reactive power, Model Reference Adaptive System (MRAS).

$x^*$  Command value of  $x$   
 $\text{Im}(x)$  Imaginary part of  $x$   
 $s, r, L$  Stator, rotor, and load lower suffixes  
 $a, b$   $a$ - $b$  fixed stator frame lower suffixes  
 $d, q$   $d$ - $q$  synchronous frame lower suffixes

## I. INTRODUCTION

Field Oriented Control (FOC) of induction motors has achieved a quick torque response, and has been applied in various industrial applications instead of dc motors. FOC, however, is very sensitive to flux estimation (magnitude and orientation) which is mainly affected by parameter variations. It depends on accurate parameter identification to achieve the expected performance [1-2]. Generally, the flux is estimated according to the Park model based parameters [3]. However, these parameters are altered by physical phenomena such as temperature, saturation, and skin effect [4]. Therefore, any parameter mismatch in flux estimation will detrimentally affect the torque response and then the FOC dynamic performance. For these reasons, many research studies have been done on automated tuning of induction motors parameters. Most of the conventional tuning techniques, however, were based on off-line parameter measurement [5]. They are effective to obtain automated and highly accurate adjustments of the motor parameters but these parameters vary during operation and are not dynamically compensated. Moreover, the off-line test itself is complicated and time consuming. Therefore, the concept of on-line identification ought to be introduced to overcome the above problems and also to dynamically optimize the identified parameters [6-8].

This paper proposes, in the frame of parameter identification, an alternative rotor resistance identification method used for a Direct Field Oriented Control (DFOC) of induction motors. This identification method has adaptability to magnetizing inductance and robustness against stator resistance. It is based on the Model Reference Adaptive System (MRAS) method. Several methods exist for identifying induction motor parameters with MRAS; they use different mathematical models of the motor or different error signals in the identification algorithm [9-11]. The proposed

## NOMENCLATURE

$v_s$	Stator voltage
$i_s$	Stator current
$\phi_r$	Rotor flux
$T$	Output torque
$Q$	Reactive power
$R_s (R_r)$	Stator (rotor) resistance
$L_s (L_r)$	Stator (rotor) inductance
$M$	Mutual inductance
$T_r$	Rotor time constant, $T_r = L_r / R_r$
$\sigma$	Total leakage coefficient, $\sigma = 1 - M^2 / (L_s L_r)$
$J$	Rotor inertia
$p$	Number of pole pair
$\Omega$	Rotor speed
$\omega_s$	Stator frequency
$s$	Differential operator
$\bar{x}$	Complex notation of $x$
$\bar{x}^c$	Complex conjugate of $x$
$\hat{x}$	Estimated value of $x$

method uses the induction motor instantaneous reactive power to avoid sensitivity to stator resistance. In fact, the instantaneous reactive power allows the estimation of the rotor flux through its resistance, using rotor current model. This model is independent of the stator resistance, but uses the inverse rotor time constant and magnetizing inductance. In our case, the magnetizing inductance was considered constant, which means that saturation was not taken into account [12-13]. In fact, from a physical point of view, temperature increase in operating induction motors normally leads to perturb and slow down the magnetic saturation establishment. Consequently, the proposed identification method can be achieved with on-line tuning of the inverse rotor time constant with robustness against stator resistance variation. In what follows, theoretical analysis is developed, and results of computer simulations are presented.

## II. INDUCTION MOTOR DIRECT FIELD ORIENTED CONTROL

An induction motor can be represented by the following equations in the  $a$ - $b$  fixed stator frame.

$$\begin{bmatrix} \bar{v}_s \\ 0 \end{bmatrix} = \begin{bmatrix} R_s & s \frac{M}{L_r} \\ -\frac{M}{T_r} & s + \frac{1}{T_r} - jp\Omega \end{bmatrix} \begin{bmatrix} \bar{i}_s \\ \bar{\Phi}_r \end{bmatrix}, \quad (1)$$

$$\begin{cases} \frac{d\Omega}{dt} = \frac{T - T_L}{J} \\ T = p \frac{M}{JL_r} (\Phi_{ra} i_{sb} - \Phi_{rb} i_{sa}) \end{cases}. \quad (2)$$

The rotor flux orientation is achieved by the following transformation (from the  $a$ - $b$  fixed stator frame to the  $d$ - $q$  synchronous frame).

$$\begin{bmatrix} x_d \\ x_q \end{bmatrix} = \frac{1}{\sqrt{\Phi_{ra}^2 + \Phi_{rb}^2}} \begin{bmatrix} \Phi_{ra} & \Phi_{rb} \\ -\Phi_{rb} & \Phi_{ra} \end{bmatrix} \begin{bmatrix} x_a \\ x_b \end{bmatrix}. \quad (3)$$

This transformation leads to

$$\begin{cases} \Phi_{rd} = \sqrt{\Phi_{ra}^2 + \Phi_{rb}^2} \\ \Phi_{rq} = 0 \end{cases}. \quad (4)$$

Figure 1 shows the general configuration of a DFOC to be studied. The rotor flux, based on a rotor model (1), is estimated using the stator currents  $i_{sa}$  and  $i_{sb}$ , and the rotor speed, as illustrated by the block diagram of Fig. 2. As shown in Fig. 1, on the  $d$ - $q$  coordinates rotating synchronously with the flux amplitude, the flux amplitude and the output torque can be controlled by manipulating the flux component current  $i_d$  and the torque component current  $i_q$  respectively.

Comparatively to the work reported in [11], the flux estimation error is only brought by  $T_r$  mismatch. The magnetic saturation is neglected on the basis of a physical consideration. In fact, the induction motor temperature increase (thermal effect), due to its operation, will perturb and slow down the magnetic saturation process. This has led us to consider  $M$  as a constant. Therefore, the flux estimation error is only caused by thermal variation.

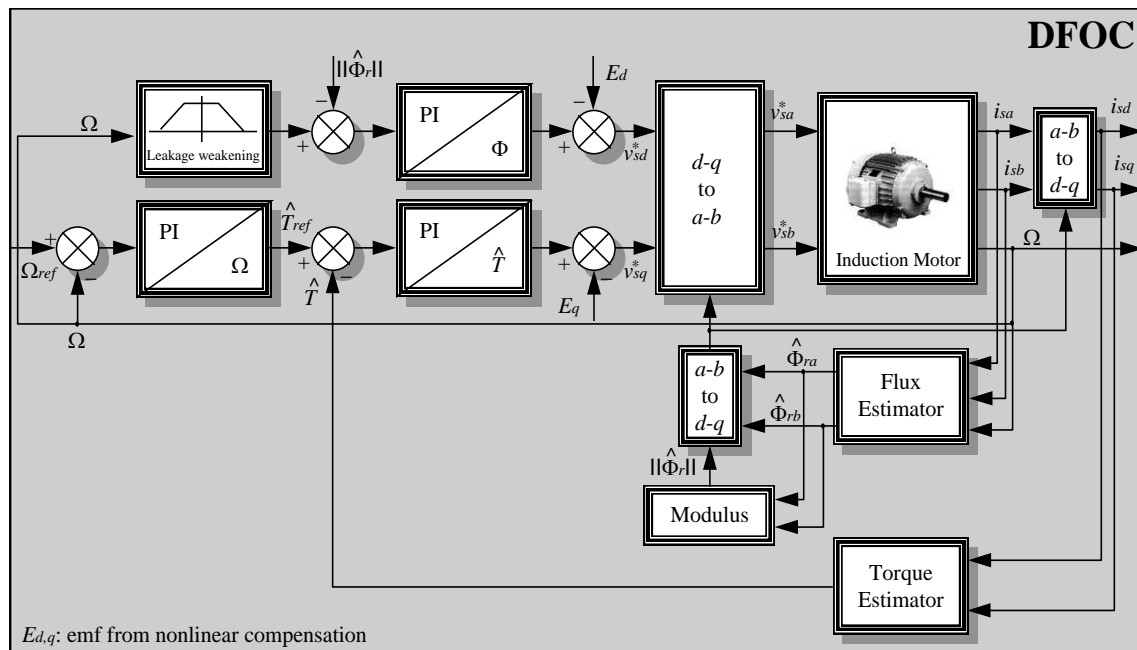

Fig. 1. General structure of an induction motor direct field oriented control.

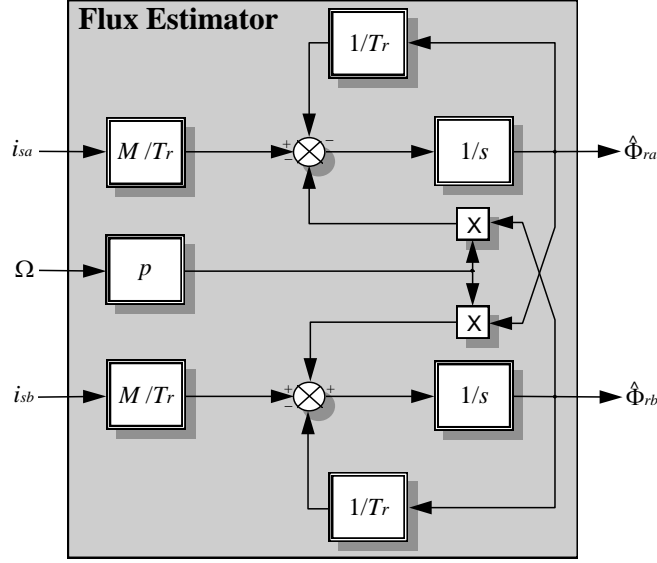

Fig. 2. Rotor flux estimator.

### III. ROBUST ROTOR RESISTANCE IDENTIFICATION

In what follows, the authors are investigating the use of the induction motor instantaneous reactive power consumption for rotor resistance identification on the basis of the MRAS method. In fact, from a practical point of view, the instantaneous reactive power can give quite sufficient real time information on the induction motor behavior.

#### A. Rotor Time Constant and Reactive Power

The induction motor reactive power could be obtained by differentiating equation (1) second row.  $Q_r$  is then expressed by the following equation for a given rotor speed  $\Omega$ .

$$Q_r = \text{Im} \left[ s \Phi_r \bar{i}_s^c \right] = \text{Im} \left[ \frac{M s i_s \bar{i}_s^c}{1 + (s - j p \Omega) T_r} \right]. \quad (5)$$

Since the on-line proposed technique in this paper aims at providing rotor resistance compensation capability in the steady state ( $s = j \omega_s$ ),  $Q_r$  becomes

$$Q_r = \frac{\omega_s M i_s^2}{1 + (\omega_s - p \Omega)^2 T_r^2}. \quad (6)$$

Equation (6) explicitly shows that it is possible to control the rotor time constant by means of the reactive power. It should be noticed that this technique is a practical way for  $T_r$  ( $R_r$ ) identification independently of  $R_s$ .

The reference reactive power is defined by the following equation in the  $a$ - $b$  fixed stator frame.

$$Q = \text{Im} \left[ \bar{v}_s \bar{i}_s^c \right]. \quad (7)$$

The right-hand side of (7) can be evaluated using the measured  $v_{sab}$  et  $i_{sab}$ . This means that it always provides a true value because no parameters of the induction motor are used. On the other hand, substituting  $v_{sab}$  of (1) in (7),  $Q$  can now be expressed as

$$Q = \text{Im} \left[ \left( R_s \bar{i}_s + \sigma L_s s \bar{i}_s + \frac{M}{L_r} s \bar{\Phi}_r \right) \bar{i}_s^c \right]. \quad (8)$$

In (8),  $R_s$  is canceled out. Equation (8) requires  $\Phi_r$  which is estimated by the flux simulator shown in Fig. 2. The simulator uses the estimated value of  $T_r$ . Equation (8) could then be replaced by

$$\hat{Q} = \text{Im} \left[ \left( l_\sigma s \bar{i}_s + s \bar{\Phi}_r \right) \bar{i}_s^c \right], \quad (9)$$

where

$$\begin{cases} l_\sigma = \sigma L_s \\ \bar{\Phi}_r = \frac{M}{L_r} \bar{\Phi}_r \end{cases}. \quad (10)$$

The error  $\Delta Q$  ( $\Delta Q = Q_{\text{measured}} - Q_{\text{estimated}}$ ) is then used to adjust  $T_r$  estimated value in the flux simulator.

### B. Identification Method Implementation

Figure 3 shows the MRAS method implementation based on the induction motor reactive power.

## IV. SIMULATION RESULTS

Numerical simulations have been carried out, on a 4-kW induction motor which ratings are summarized in the appendix, to analyze the DFOC performance using the proposed identification method. For simulation purposes, the motor was loaded with a torque of 5 N·m and controlled with a reference speed of 157 rd/s. Moreover, the rotor resistance was given an exponential profile intended to cover the temperature effect; and the stator resistance was varied so as  $R_s = 200\% R_{snom}$ .

The following figures show simulation results under the above conditions. In Fig. 4, it is observed that rotor resistance identification is satisfactory. Moreover, it was found, as expected, insensitive to  $R_s$  variation.

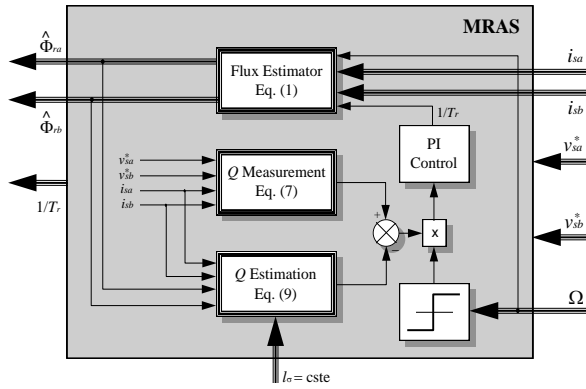

Fig. 3. Rotor time constant identification.

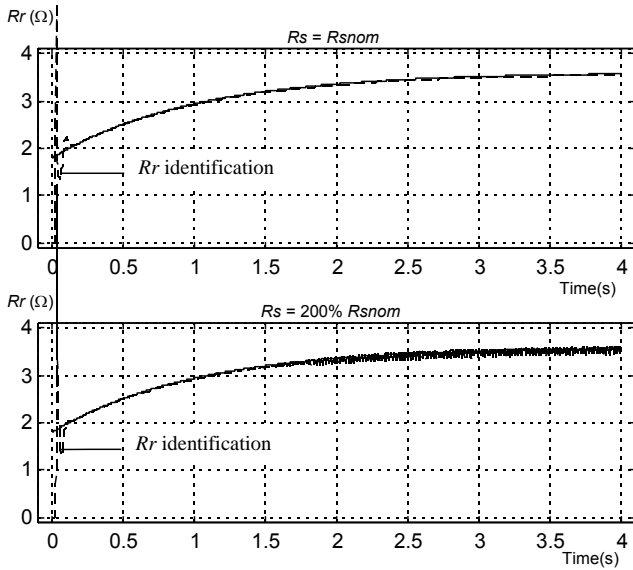

Fig. 4. Rotor resistance identification under temperature effect.

On the other hand in Fig. 5, shows the flux estimation when the induction motor is controlled by the DFOC strategy according to Fig. 1. The estimation process start has been purposely slightly delayed to clearly illustrate its beginning. The estimation process could then be considered as satisfactory and quite insensitive to  $R_s$  variation.

Finally, as shown in Fig. 6, the DFOC robustness, using the proposed identification method, is clearly illustrated. In fact, the speed and the torque are insensitive to  $R_s$  variations.

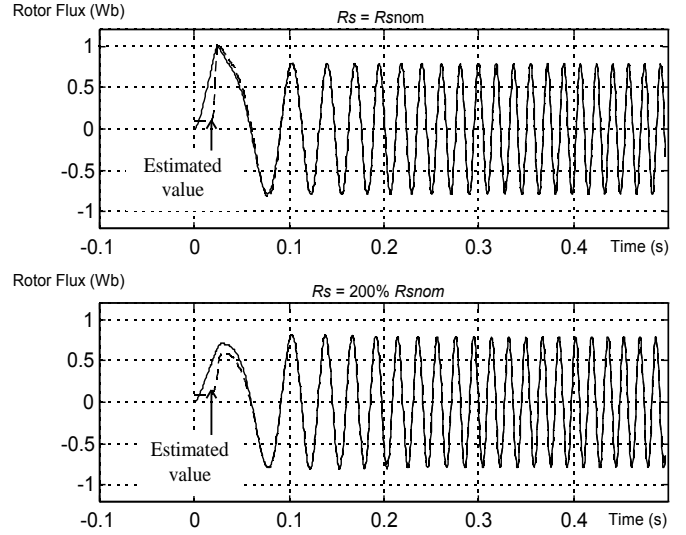

Fig. 5. Rotor flux estimation with  $R_r$  mismatch.

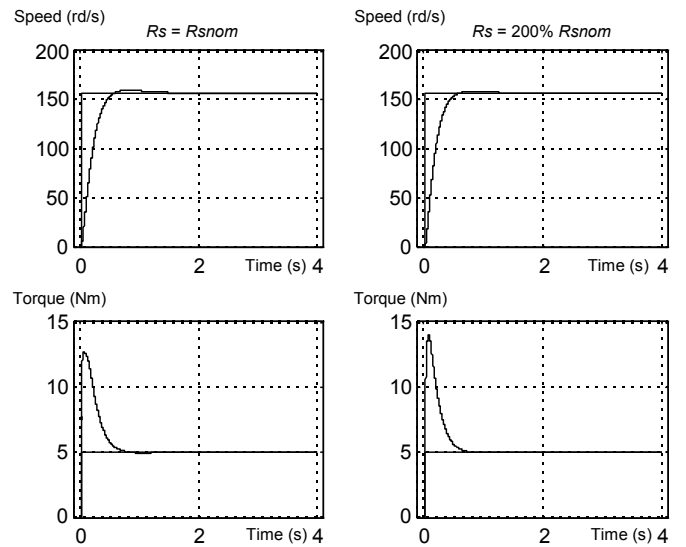

Fig. 6. DFOC robustness with  $R_s$  mismatch.

## V. CONCLUSION

This paper proposes, in the frame of parameter identification, an alternative rotor resistance identification method used for a DFOC of induction motors. This identification method has adaptability to magnetizing inductance and robustness against stator resistance. It is based on the MRAS method using the induction motor instantaneous reactive power to avoid sensitivity to stator resistance. The instantaneous reactive power allows the estimation of the rotor flux through its resistance, using rotor current model. This model is independent of the stator resistance, but uses the inverse rotor time constant and magnetizing inductance. In our case, the magnetizing inductance was considered constant, which means that saturation was not taken into account. Consequently, the proposed identification method have been achieved with on-line tuning of the inverse rotor time constant with robustness against stator resistance variation.

## APPENDIX

### PARAMETERS OF THE SIMULATED INDUCTION MOTOR

Rated values	Power	4	kW
	Frequency	50	Hz
	Voltage ( $\Delta/Y$ )	220/380	V
	Current ( $\Delta/Y$ )	15/8.6	A
	Speed	1440	rpm
	Pole pair ( $p$ )	2	
Rated parameters	$R_s$	1.2000	$\Omega$
	$R_r$	1.8000	$\Omega$
	$L_s$	0.1554	H
	$L_r$	0.1568	H
	$M$	0.1503	H
	$l_\sigma$	0.0113	H
	$J$	0.0130	kg.m <sup>2</sup>

## VI. REFERENCES

- [1] N.R. Klaes, "Accurate off-line identification of the operating point dependent induction machine parameters," *Proceedings of the 1990 International Electrical Drives Symposium*, Italy, September 1990.
- [2] M. Depenbrock and N.R. Klaes, "Determination of the induction machines parameters and their dependencies on saturation," *Proceedings of the 1989 IEEE IAS Annual Meeting*, USA, October 1989, pp. 17-22.
- [3] H. Kubota, K. Matuse and T. Nakano, "DSP-based speed adaptive flux observer of induction motor," *IEEE Trans. Industry Applications*, vol. 29, n°2, March-April 1993, pp. 344-348.
- [4] R. Krishnan and A.S. Bharadwaj, "A review of parameter sensitivity and adaptation indirect vector controlled induction motor drive systems," *IEEE Trans. Power Electronics*, vol. 6, n°4, October 1991, pp. 693-703.
- [5] C. Wang, D.W. Novotny and T.A. Lipo, "An automated rotor time constant measurement system for indirect field-oriented drives," *IEEE Trans. Industry Applications*, vol. 24, n°1, January-February 1988, pp. 151-159.
- [6] L.J. Garcés, "Parameter adaption for the speed-controlled static ac drive with squirrel-cage induction motor," *IEEE Trans. Industry Applications*, vol. 16, n°2, March-April 1980, pp. 173-178.
- [7] K. Tungpimolrut, F. Peng and T. Fukao, "Robust vector control of induction motor without using stator and rotor circuit time constants," *Proceedings of the 1993 IEEE IAS Annual Meeting*, USA, October 1993, pp. 521-527.

- [8] T.M. Rowan, R.J. Kerkman and D. Leggate, "A simple on-line adaption for indirect field orientation of an induction machine," *IEEE Trans. Industry Applications*, vol. 27, n°4, July-August 1991, pp. 720-727.
- [9] K. Ohnishi, Y. Ueda and K. Miyachi, "Model reference adaptive system against rotor resistance variation in induction motor drive," *IEEE Trans. Industrial Electronics*, vol. 33, n°3, August 1986, pp. 217-223.
- [10] R. Beguenane, M.E.H. Benbouzid, M. Tadjine and A. Tayebi, "Speed and rotor time constant estimation via MRAS strategy for induction motor drives," *Proceedings of the 1997 IEEE Electrical Machines and Drives Conference*, Milwaukee, Wisconsin (USA), May 1997, pp. TB3-5.1-5.3.
- [11] T. Noguchi, S. Kendo and I. Takahashi, "Field-oriented control of an induction motor with robust on-line tuning of its parameters," *IEEE Trans. Industry Applications*, vol. 33, n°1, January- February 1997, pp. 35-42.
- [12] R. Beguenane and M.E.H. Benbouzid, "Induction motors thermal monitoring by means of rotor resistance identification," *IEEE Trans. Energy Conversion*, Ref. PE-I155-EC-0-2-1998.
- [13] M.S. Naït Saïd, M.E.H. Benbouzid, R. Beguenane and N. Naït Saïd, "H-G diagram based rotor parameters identification for induction motors thermal monitoring purpose," *IEEE Trans. Energy Conversion*, Ref. 98-WM-89.

## VII. BIOGRAPHIES



**Mohamed Saïd NAIT SAÏD** was born in Batna, Algeria, on September 15, 1958. He received the *B.Sc.* degree in Electrical Engineering, in 1983, from the National Polytechnic Institute of Algiers, Algeria and the *M.Sc.* degree in Electrical and Computer Engineering, in 1992, from the Electrical Engineering Institute of Constantine University, Algeria. After graduation, he joined the University of Batna, Algeria, where he is a Teaching Assistant at the Electrical Engineering Institute. M.S. Naït Saïd is actually working towards a *Ph.D.* thesis on the control of induction motors in the University of Picardie "Jules Verne" at Amiens, France.



**Mohamed El Hachemi BENBOUZID** (S'92-M'94-SM'98) was born in Batna, Algeria, in 1968. He received the *B.Sc.* degree in Electrical Engineering, in 1990, from the Electrical Engineering Institute of Batna University, Algeria; the *M.Sc.* and *Ph.D.* degrees both in Electrical and Computer Engineering, from the National Polytechnic Institute of Grenoble, France, in 1991 and 1994 respectively. After graduation, he joined the University of Picardie "Jules Verne", France, where he is an Associate Professor of Electrical and Computer Engineering at the Professional Institute of Amiens. His current research interests include electric machines and drives, computational of electromagnetics, and electromechanical actuation, as well as techniques for energy savings. Dr. Benbouzid is a member of the IEEE Industrial Electronics, Industry Applications, Power Engineering, and Magnetics Societies, and the French Electrotechnical and Electronic Association (SEE). He is particularly active in the IEEE Power Engineering Society Working Group on Motor Maintenance and Failure Analysis of the Induction Machinery Subcommittee of the Electric Machines Committee. (phone +33 3 22 82 76 80, Fax +33 3 22 82 78 22, e-mail m.benbouzid@ieec.org)